

PROJECT REFERENCE NO. B-4159	SHEET NO. S-59
DESIGNED BY: VW	
DRAWN BY: VW	
CHECKED BY: MJW	
APPROVED BY:	
REVISD: 9/14/15	
UTILITY CONSTRUCTION RESTRAINED JOINT PIPE DETAILS	

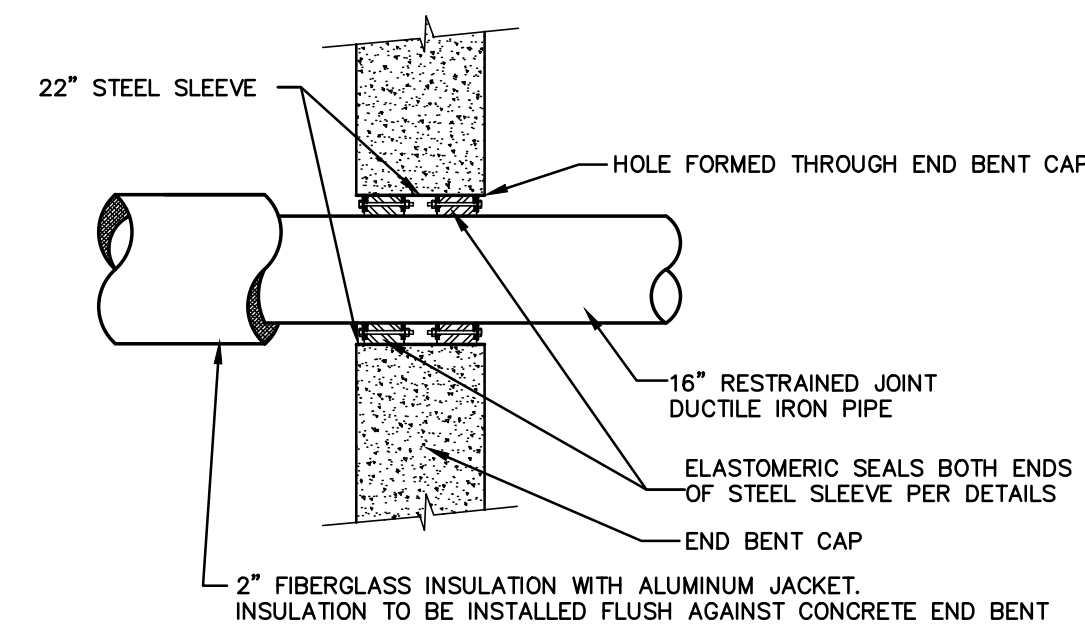

PIPE THROUGH END BENT CAP

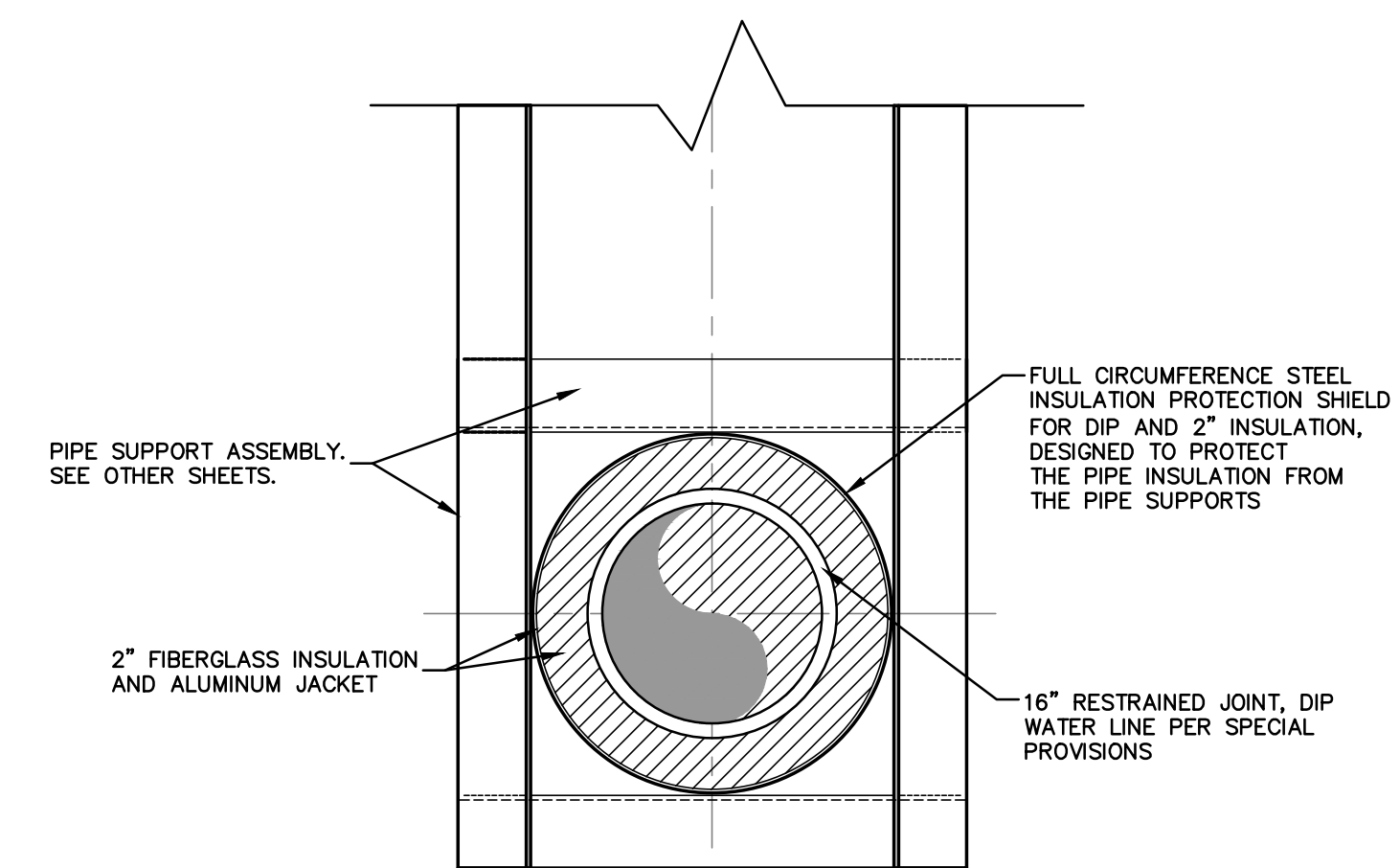

NOTE:

1. PIPE INSULATION SHALL BE FIBERGLASS PIPE INSULATION WITH DOUBLE ADHESIVE CLOSURE.

PIPE INSULATION DETAIL

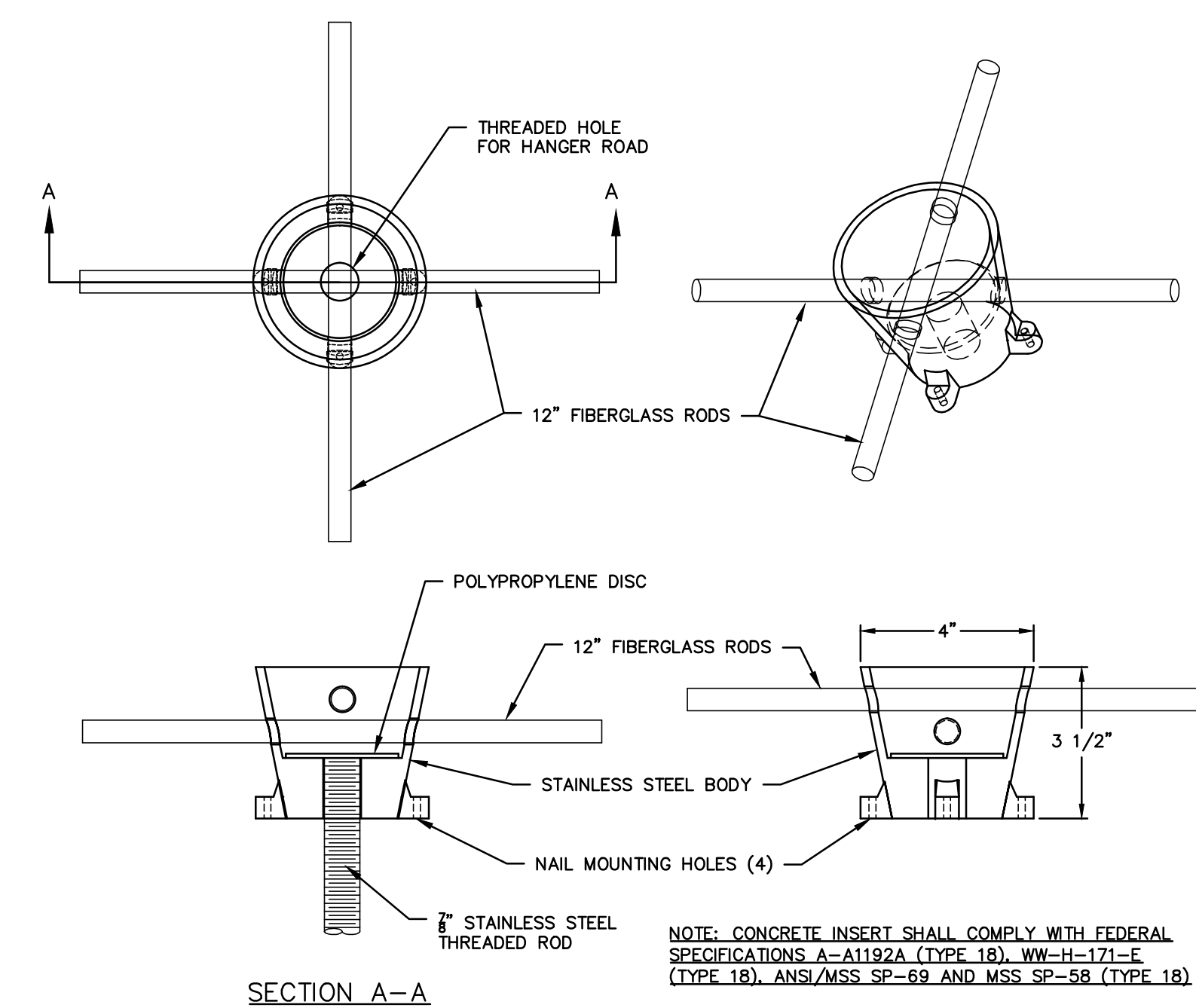

NOTE: CONCRETE INSERT SHALL COMPLY WITH FEDERAL SPECIFICATIONS A-A1192A (TYPE 1B), WW-H-171-E (TYPE 1B), ANSI/MSS SP-69 AND MSS SP-58 (TYPE 1B).

SECTION A-A

CONCRETE INSERT

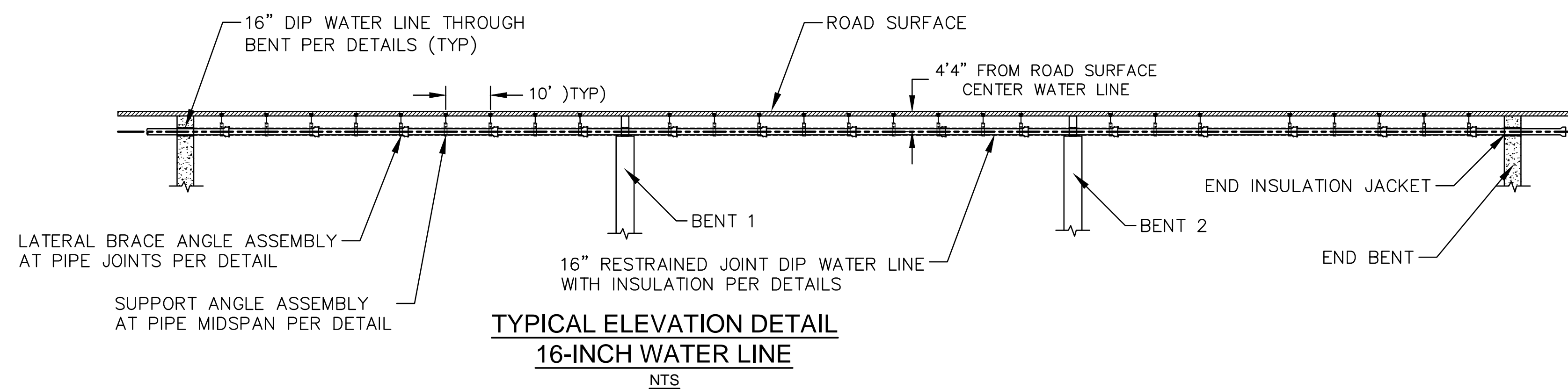

**TYPICAL ELEVATION DETAIL
16-INCH WATER LINE**

NTS

REVISIONS