

**This electronic collection of documents is provided
for the convenience of the user
and is Not a Certified Document –**

**The documents contained herein were originally issued
and sealed by the individuals whose names and license
numbers appear on each page, on the dates appearing
with their signature on that page.**

**This file or an individual page
shall not be considered a certified document.**



PROJECT: W-5519

CONTRACT:

STATE OF NORTH CAROLINA
DEPARTMENT OF TRANSPORTATION

PAVEMENT MARKING PLANS
CUMBERLAND COUNTY

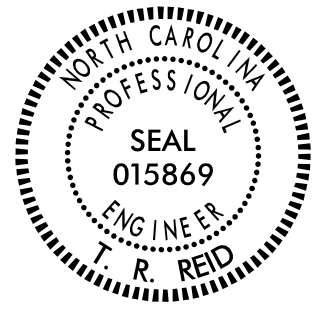
LOCATION: I-95 BUSINESS /US 301 FROM NC 87 SOUTH TO NC 59

PROJECT REFERENCE NO. W-5519	SHEET NO. PMP-1
APPROVED: <u>Timothy R. Reid</u> <small>DocuSigned by: 28568A242E8411...</small>	
DATE: 9/10/2015	
SEAL 	
 moffatt & nichol <small>1616 EAST MILLBROOK ROAD, SUITE 160 RALEIGH, NORTH CAROLINA 27609 (919) 781-4626 VOICE (919) 781-4869 FAX</small>	

ROADWAY STANDARD DRAWINGS

THE FOLLOWING ROADWAY STANDARDS AS SHOWN IN "ROADWAY STANDARD DRAWINGS" - PROJECT SERVICES UNIT - N.C. DEPARTMENT OF TRANSPORTATION - RALEIGH, N.C., DATED JANUARY 2012 ARE APPLICABLE TO THIS PROJECT AND BY REFERENCE HEREBY ARE CONSIDERED A PART OF THESE PLANS:

STD. NO.	TITLE
1205.01	PAVEMENT MARKINGS - LINE TYPES AND OFFSETS
1205.02	PAVEMENT MARKINGS - TWO-LANE AND MULTI-LANE ROADWAYS
1205.04	PAVEMENT MARKINGS - INTERSECTIONS
1205.05	PAVEMENT MARKINGS - TURN LANES
1205.06	PAVEMENT MARKINGS - LANE DROPS
1205.08	PAVEMENT MARKINGS - SYMBOLS AND WORD MESSAGES
1205.09	PAVEMENT MARKINGS - PAINTED ISLANDS
1250.01	RAISED PAVEMENT MARKERS - INSTALLATION SPACING
1251.01	RAISED PAVEMENT MARKERS - PERMANENT AND TEMPORARY
1261.01	GUARDRAIL AND BARRIER DELINEATORS - INSTALLATION SPACING
1261.02	GUARDRAIL AND BARRIER DELINEATORS - TYPES AND MOUNTING
1262.01	GUARDRAIL END DELINEATION

INDEX

SHEET NO.	DESCRIPTION
PMP-1	PAVEMENT MARKING PLAN COVER SHEET
PMP-2	PAVEMENT MARKING LEGEND & SCHEDULE
PMP-3 THRU PMP-26	PAVEMENT MARKING DETAILS

PLAN REVIEWED BY: NCDOT SIGNING AND DELINEATION UNIT

<u>AYMAN ALQUDWAH, PE</u>	SIGNING & DELINEATION REGIONAL ENGINEER
<u>BASIR RASHID</u>	SIGNING & DELINEATION PROJECT DESIGN ENGINEER

GENERAL NOTES

THE FOLLOWING GENERAL NOTES APPLY AT ALL TIMES FOR THE DURATION OF THE CONSTRUCTION PROJECT, EXCEPT WHEN OTHERWISE NOTED IN THE PLAN, OR DIRECTED BY THE ENGINEER.

A) INSTALL PAVEMENT MARKINGS AND PAVEMENT MARKERS ON THE FINAL SURFACE AS FOLLOWS:

ROAD NAME	MARKING	MARKER
-L- (I-95BUS / US 301)	THERMOPLASTIC	RAISED

B) TIE PROPOSED PAVEMENT MARKING LINES TO EXISTING PAVEMENT MARKING LINES.

C) REMOVE / REPLACE ANY CONFLICTING / DAMAGED PAVEMENT MARKINGS AND MARKERS THAT HAVE BEEN DAMAGED BY THE END OF EACH DAY'S OPERATION.

D) PASSING ZONES WILL BE DETERMINED IN THE FIELD AND MUST BE APPROVED BY THE ENGINEER.

E) MARKERS SHALL BE INSTALLED ACCORDING TO THE NCDOT ROADWAY STANDARD DRAWING 1250.01.

F) STOP BAR LOCATIONS AT NON-SIGNALIZED INTERSECTIONS MAY BE ADJUSTED AS DIRECTED BY THE ENGINEER.

G) UNLESS OTHERWISE SPECIFIED, HEATED IN-PLACE THERMOPLASTIC MAY BE USED IN LIEU OF EXTRUDED THERMOPLASTIC FOR STOP BARS, SYMBOLS, CHARACTERS AND DIAGONALS. IF HEATED IN-PLACE IS USED, IT SHALL BE PAID FOR USING THE EXTRUDED THERMOPLASTIC PAY ITEM.

PLAN PREPARED BY: MOFFATT & NICHOL





<u>TIM REID, PE</u>	PROJECT ENGINEER
<u>TRENT HUFFMAN, PE</u>	PROJECT DESIGN

FINAL PAVEMENT MARKING SCHEDULE

MATERIAL	SYMBOL	DESCRIPTION
<u>THERMOPLASTIC (4", 90 MILS)</u>		
	TA	WHITE EDGE LINE
	TB	YELLOW EDGE LINE
<u>THERMOPLASTIC (4", 120 MILS)</u>		
	T8	WHITE MINI SKIP (2'/6')
	TI	YELLOW DOUBLE CENTER
<u>THERMOPLASTIC (6", 90 MILS)</u>		
	T6	WHITE EDGE LINE
	T7	YELLOW EDGE LINE
<u>THERMOPLASTIC (6", 120 MILS)</u>		
	T11	WHITE MINI SKIP (2'/6')
	T12	YELLOW MINI SKIP (2'/6')
	TJ	WHITE SKIP (10')
	TK	WHITE MINI SKIP (3'/9')
	TL	WHITE SOLID LANE LINE
<u>THERMOPLASTIC (8", 90 MILS)</u>		
	TP	YELLOW DIAGONAL
<u>THERMOPLASTIC (12", 90 MILS)</u>		
	TS	WHITE GORELINE
	TU	WHITE DIAGONAL
<u>THERMOPLASTIC (24", 120 MILS)</u>		
	T2	WHITE STOP BAR
<u>THERMOPLASTIC PAVEMENT MARKING SYMBOLS (90 MILS)</u>		
	UA	LEFT TURN ARROW
	UB	RIGHT TURN ARROW
	UC	STRAIGHT ARROW
	UE	COMBO. RIGHT/STRAIGHT ARROW
	UM	12" YIELD LINE TRIANGLE
	UT	U-TURN ARROW
<u>PERMANENT RAISED PAVEMENT MARKERS</u>		
	MA	YELLOW & YELLOW
	MB	CRYSTAL & RED

LEGEND

GENERAL

-  DIRECTION OF TRAFFIC FLOW
-  EXIST. PVMT.
-  NORTH ARROW
-  PROPOSED PVMT.

PAVEMENT MARKING SYMBOLS

-  PAVEMENT MARKING SYMBOLS

9/10/2015
 P:\8467\Cadd\W5519_Traffic\Signing\CADD\W5519_pmp-2.dgn
 thuffman

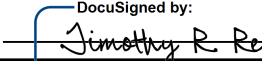
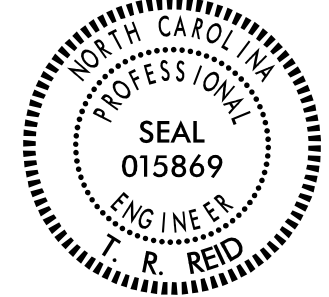
APPROVED:  DATE: 9/10/2015 2666904268911 	
---	--

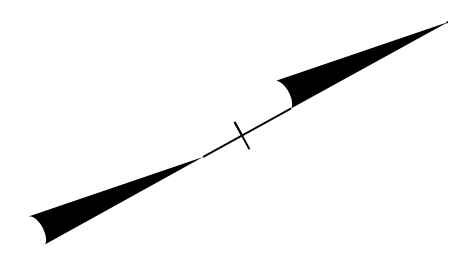

MATCHLINE -L- STA 114 + 00 SEE SHEET PMP-3

MATCHLINE -L- STA 128 + 00 SEE SHEET PMP-5

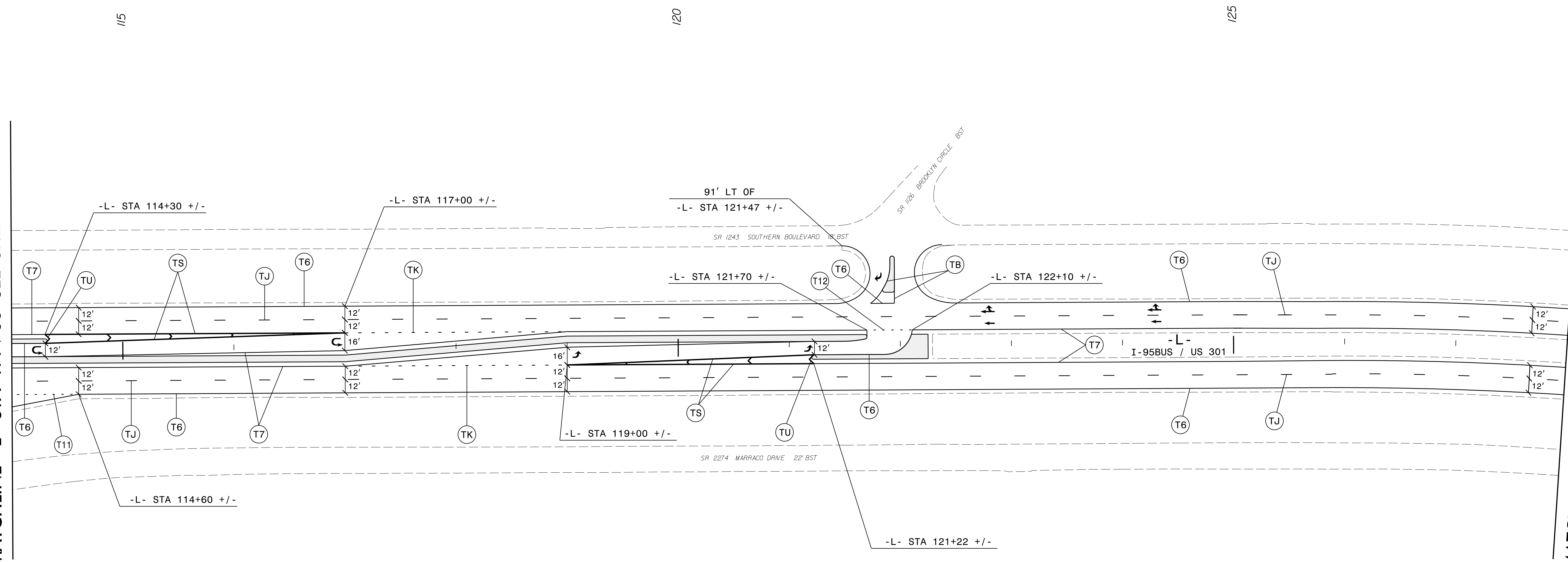

9/10/2015
 P:\8467\Cadd\W5519\Traffic\Signing\CADD\W5519_pmp-4.dgn
 thufman

mo moffatt & nichol
 1616 EAST MILLBROOK ROAD, SUITE 160
 RALEIGH, NORTH CAROLINA 27609
 (919) 781-4626 VOICE (919) 781-4869 FAX

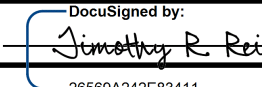
APPROVED:  DATE: 9/10/2015

25569A02020411

SEAL

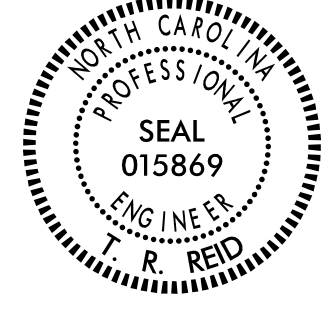

FINAL PAVEMENT MARKING PLANS

PROJ. REFERENCE NO.	SHEET NO.
W-5519	PMP-5

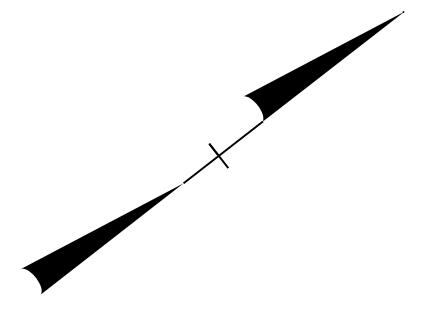

MATCHLINE -L- STA 128+00 SEE SHEET PMP-4

MATCHLINE -L- STA 140+50 SEE SHEET PMP-6

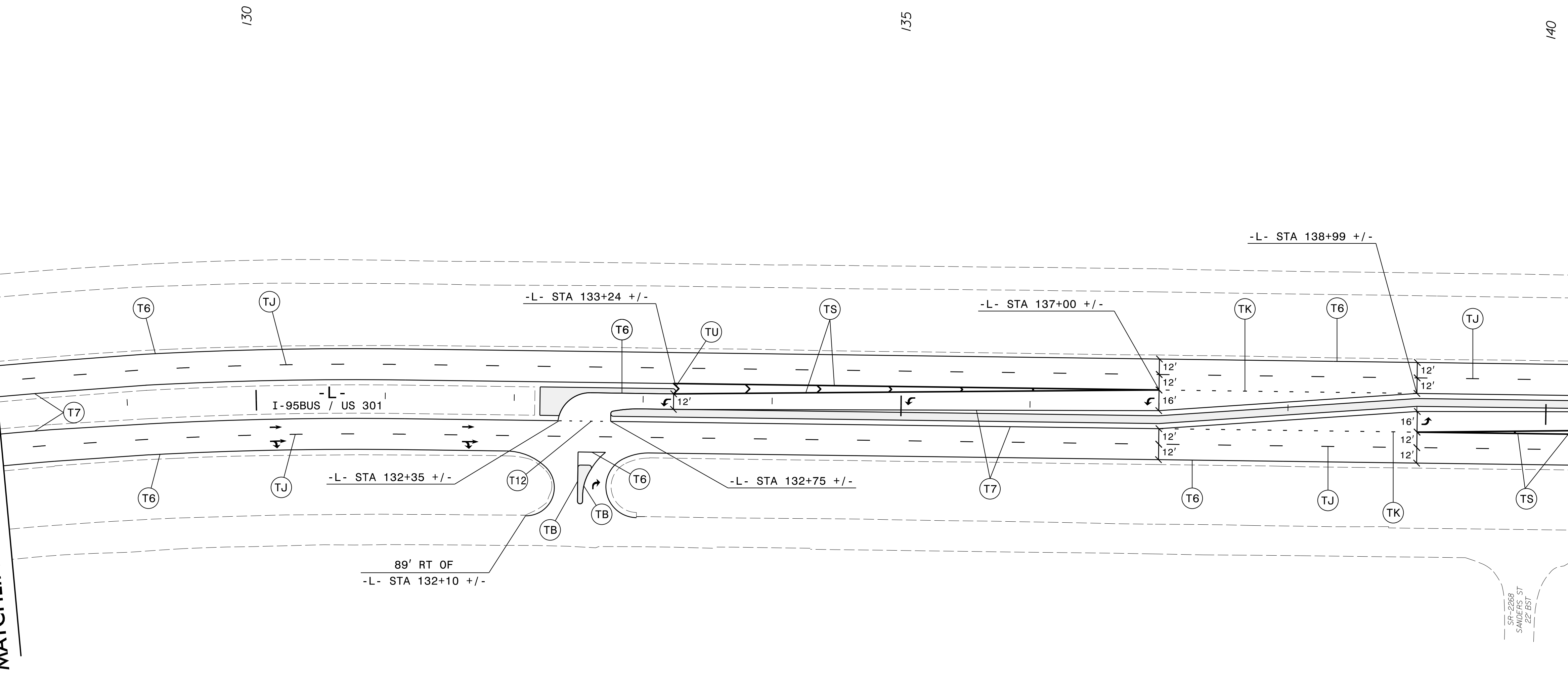

9/10/2015
P:\8467\Cadd\W5519\Traffic\Signing\CADD\W-5519_pmp_pmp-5.dgn
THUFMAN



APPROVED: DATE: 9/10/2015

SEAL

FINAL PAVEMENT MARKING PLANS

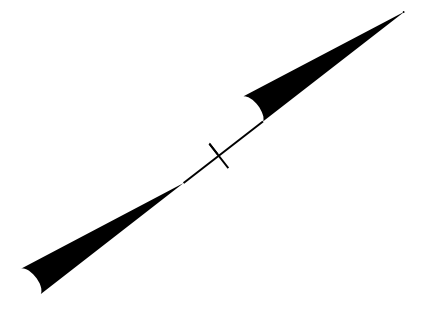

MATCHLINE -L- STA 140 + 50 SEE SHEET PMP-5

MATCHLINE -L- STA 154 + 50 SEE SHEET PMP-7

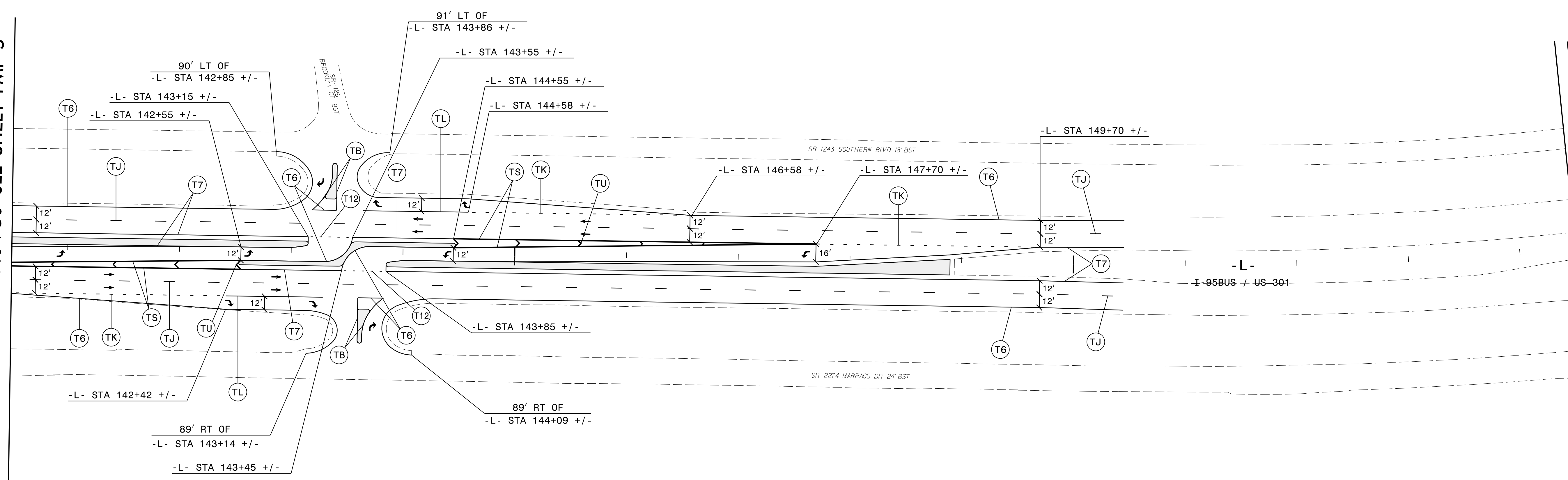

9/10/2015
P:\8467\Cadd\W5519\Traffic\Signing\CADD\W5519_pmp_6.dgn
THUFMAN

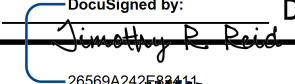

APPROVED:  DATE: 9/10/2015

SEAL

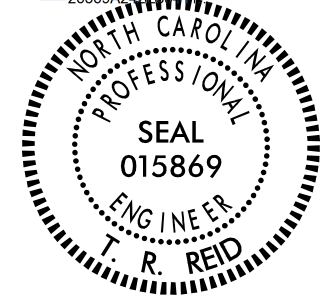

FINAL PAVEMENT MARKING PLANS

PROJ. REFERENCE NO.	SHEET NO.
W-5519	PMP-7

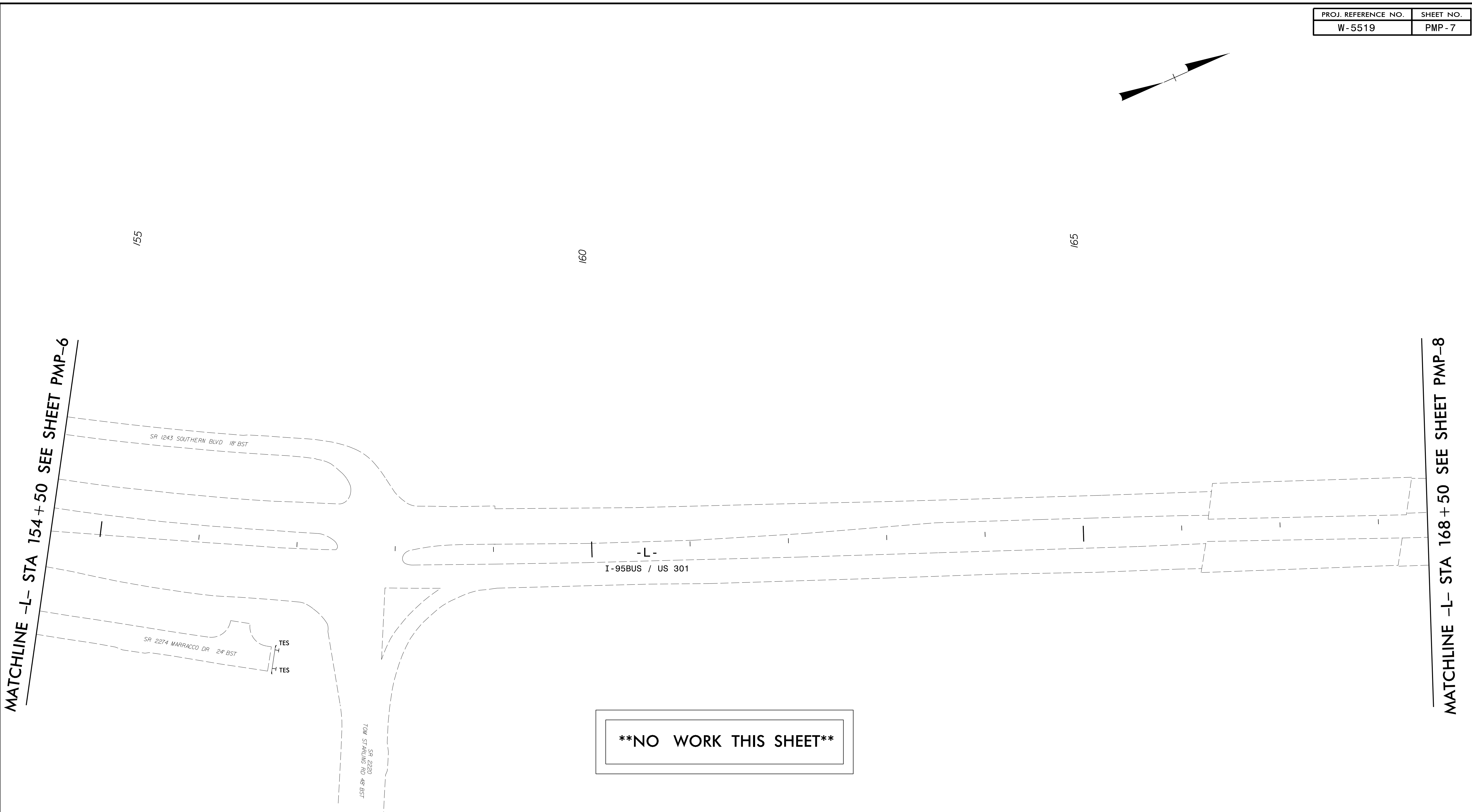
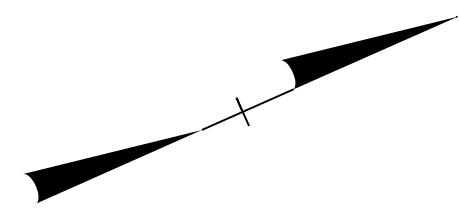

****NO WORK THIS SHEET****

9/10/2015
 P:\8467\Cadd\W5519\Traffic\Signing\CADD\W5519_pmp-7.dgn
 thuffman

moffatt & nichol
 1616 EAST MILLBROOK ROAD, SUITE 160
 RALEIGH, NORTH CAROLINA 27609
 (919) 781-4626 VOICE (919) 781-4869 FAX

APPROVED: _____ DATE: 9/10/2015
 DocuSigned by: _____
 2009923287

**FINAL PAVEMENT
 MARKING PLANS**

PROJ. REFERENCE NO.	SHEET NO.
W-5519	PMP-8

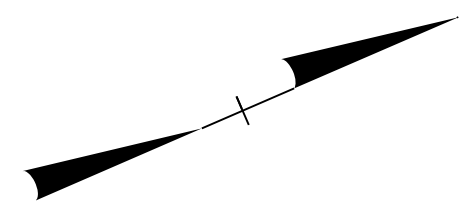

170

175

180

MATCHLINE -L- STA 168 + 50 SEE SHEET PMP-7

MATCHLINE -L- STA 182 + 50 SEE SHEET PMP-9

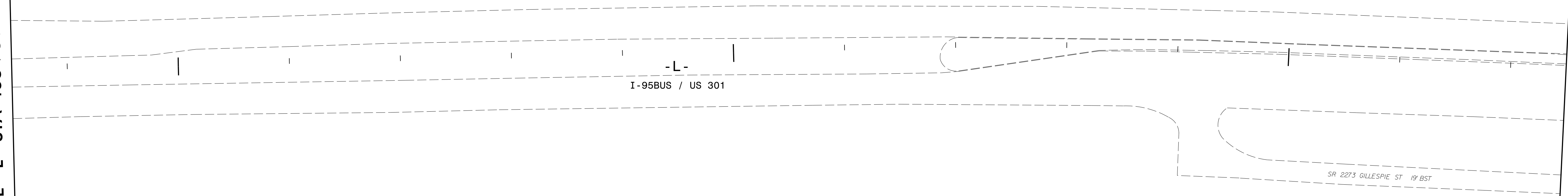

****NO WORK THIS SHEET****

9/10/2015
 P:\8467\Cadd\W5519\Traffic\Signing\CADD\W5519_PMP_PMP-8.dgn
 thuffman



APPROVED: *Jewell P. Ford* DATE: 9/10/2015

DocuSigned by:
Jewell P. Ford
26569A2428E8

SEAL

FINAL PAVEMENT MARKING PLANS

PROJ. REFERENCE NO.	SHEET NO.
W-5519	PMP-9

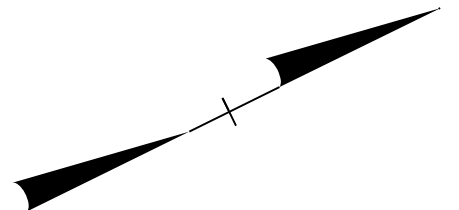

MATCHLINE -L- STA 182 + 50 SEE SHEET PMP-8

MATCHLINE -L- STA 196 + 50 SEE SHEET PMP-10

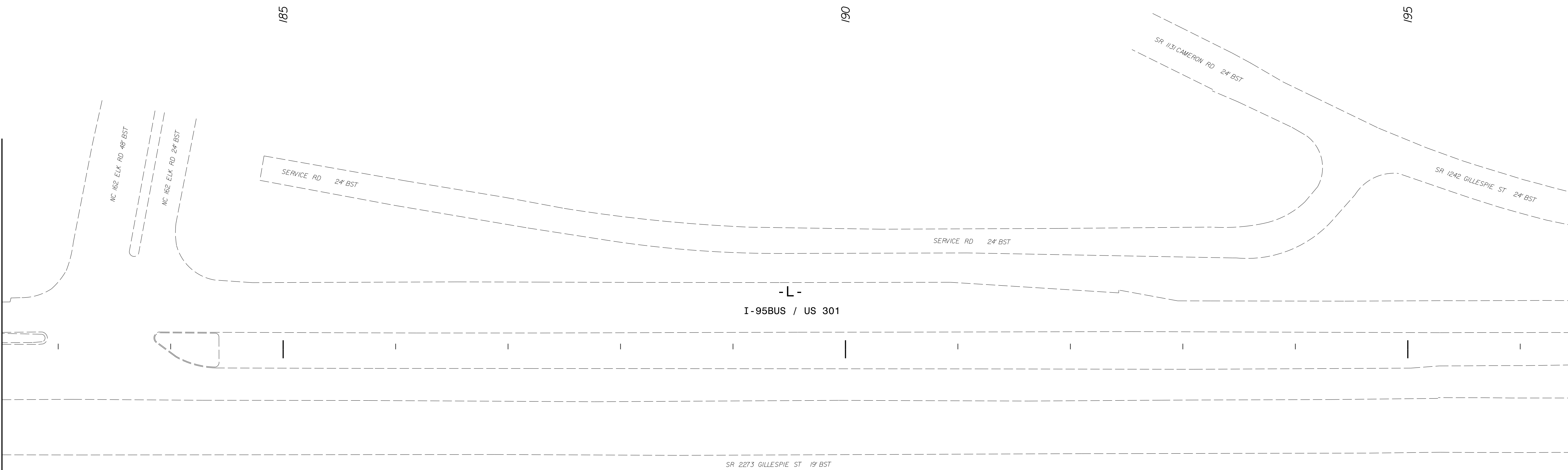

****NO WORK THIS SHEET****

9/10/2015
 P:\8457\Cadd\W5519\Traffic\Signing\CADD\PM\W-5519_pmp_pmp-9.dgn
 THufman

1616 EAST MILLBROOK ROAD, SUITE 160
 RALEIGH, NORTH CAROLINA 27609
 (919) 781-4626 VOICE (919) 781-4869 FAX

APPROVED: *DocuSigned by: Jeffrey P. Reid* DATE: 9/10/2015

SEAL

FINAL PAVEMENT MARKING PLANS

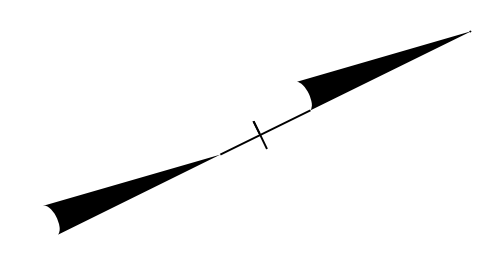

MATCHLINE -L- STA 196 + 50 SEE SHEET PMP-9

MATCHLINE -L- STA 210 + 50 SEE SHEET PMP-11

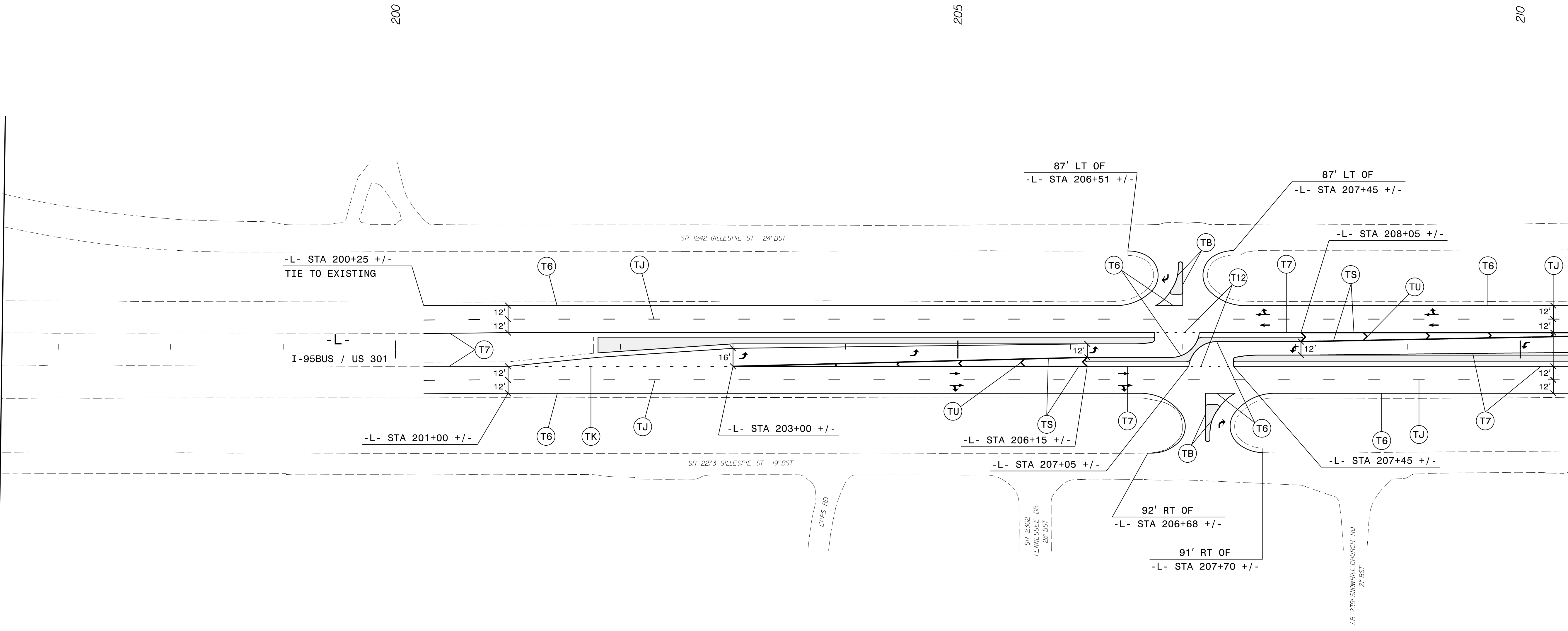

9/10/2015
P:\8467\Cadd\W5519\Traffic\Signing\CADD\W5519_pmp_pmp-10.dgn
THUFMAN

moftatt & nichol
1616 EAST MILLBROOK ROAD, SUITE 160
RALEIGH, NORTH CAROLINA 27609
(919) 781-4626 VOICE (919) 781-4869 FAX

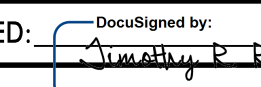
APPROVED:  DATE: 9/10/2015

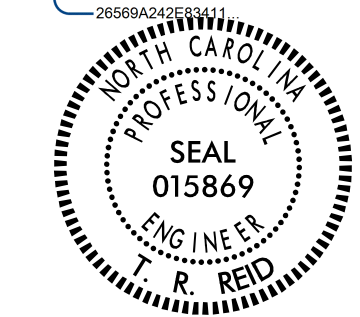
SEAL

FINAL PAVEMENT MARKING PLANS

PROJ. REFERENCE NO.	SHEET NO.
W-5519	PMP-11

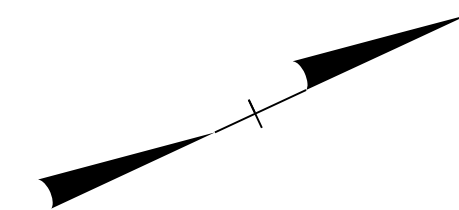

MATCHLINE -L- STA 210 + 50 SEE SHEET PMP-10

MATCHLINE -L- STA 224 + 50 SEE SHEET PMP-12

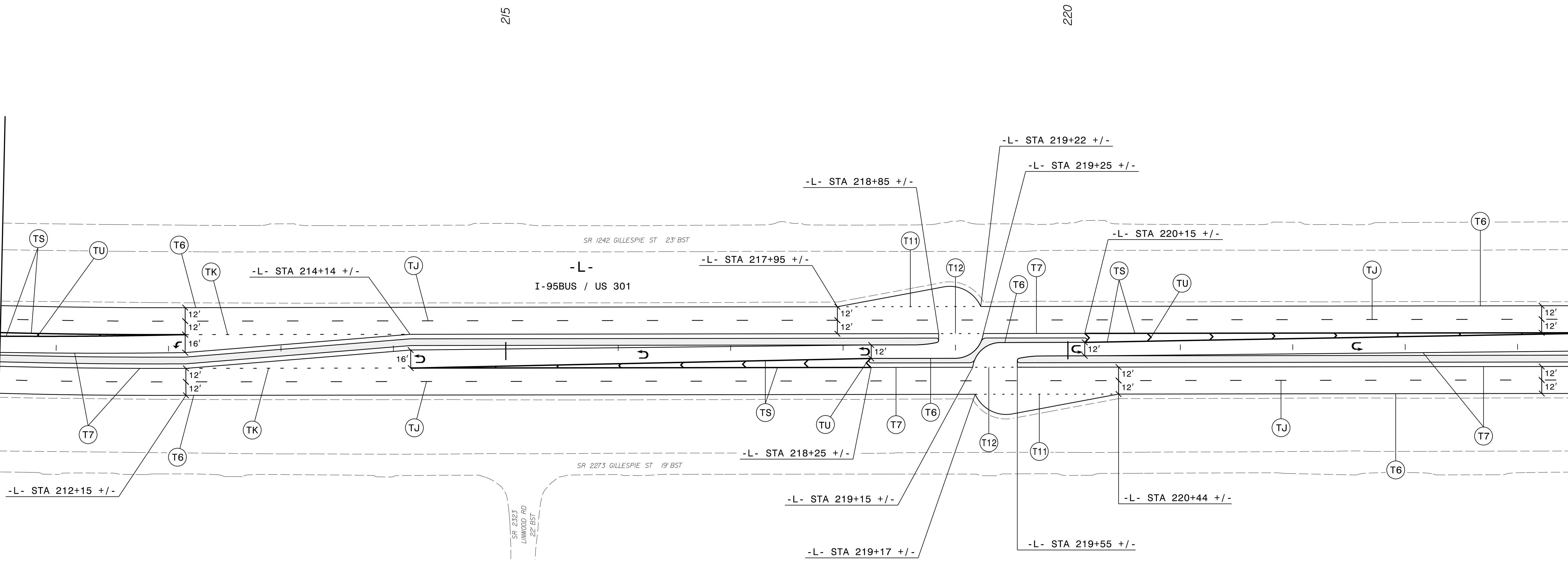

9/10/2015
P:\8457\Cadd\W5519\Traffic\Signing\CADD\W5519_PMP_PMP-11.dgn
THUFMAN

mo moffatt & nichol
1616 EAST MILLBROOK ROAD, SUITE 160
RALEIGH, NORTH CAROLINA 27609
(919) 781-4626 VOICE (919) 781-4869 FAX

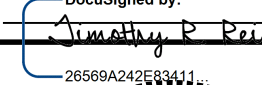
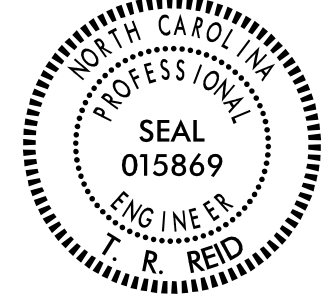
APPROVED:  DATE: 9/10/2015
SEAL

FINAL PAVEMENT MARKING PLANS

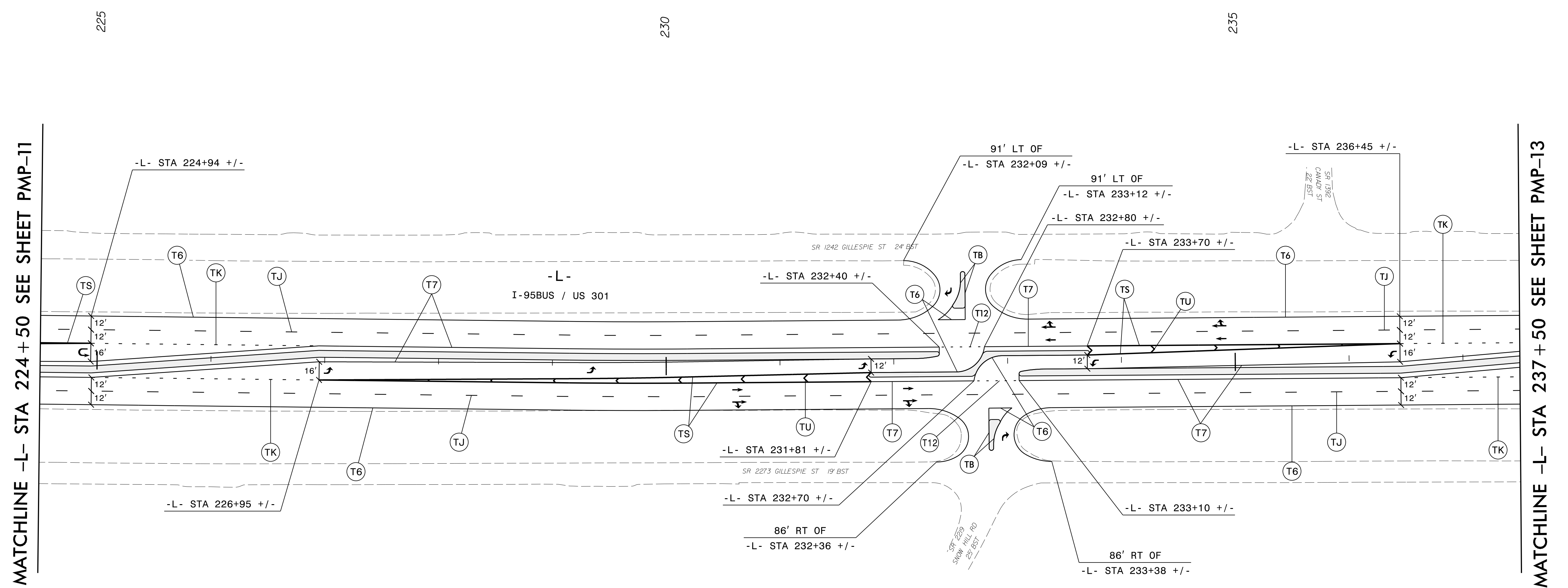
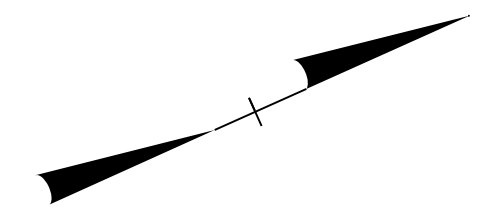

9/10/2015
 P:\8467\Cadd\W5519\Traffic\Signing\CADD\W5519_pmp-12.dgn
 T:\mfm

mo moffatt & nichol
 1616 EAST MILLBROOK ROAD, SUITE 160
 RALEIGH, NORTH CAROLINA 27609
 (919) 781-4626 VOICE (919) 781-4869 FAX

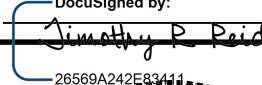
APPROVED:  DATE: 9/10/2015

SEAL

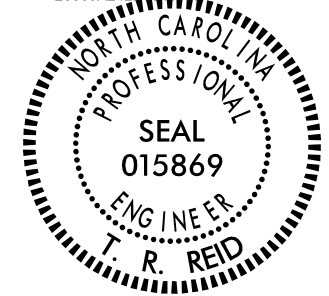

FINAL PAVEMENT MARKING PLANS

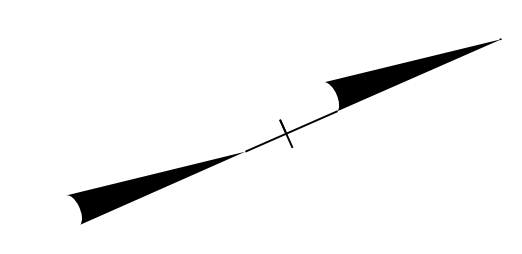

MATCHLINE -L- STA 237 + 50 SEE SHEET PMP-12

MATCHLINE -L- STA 250 + 00 SEE SHEET PMP-14

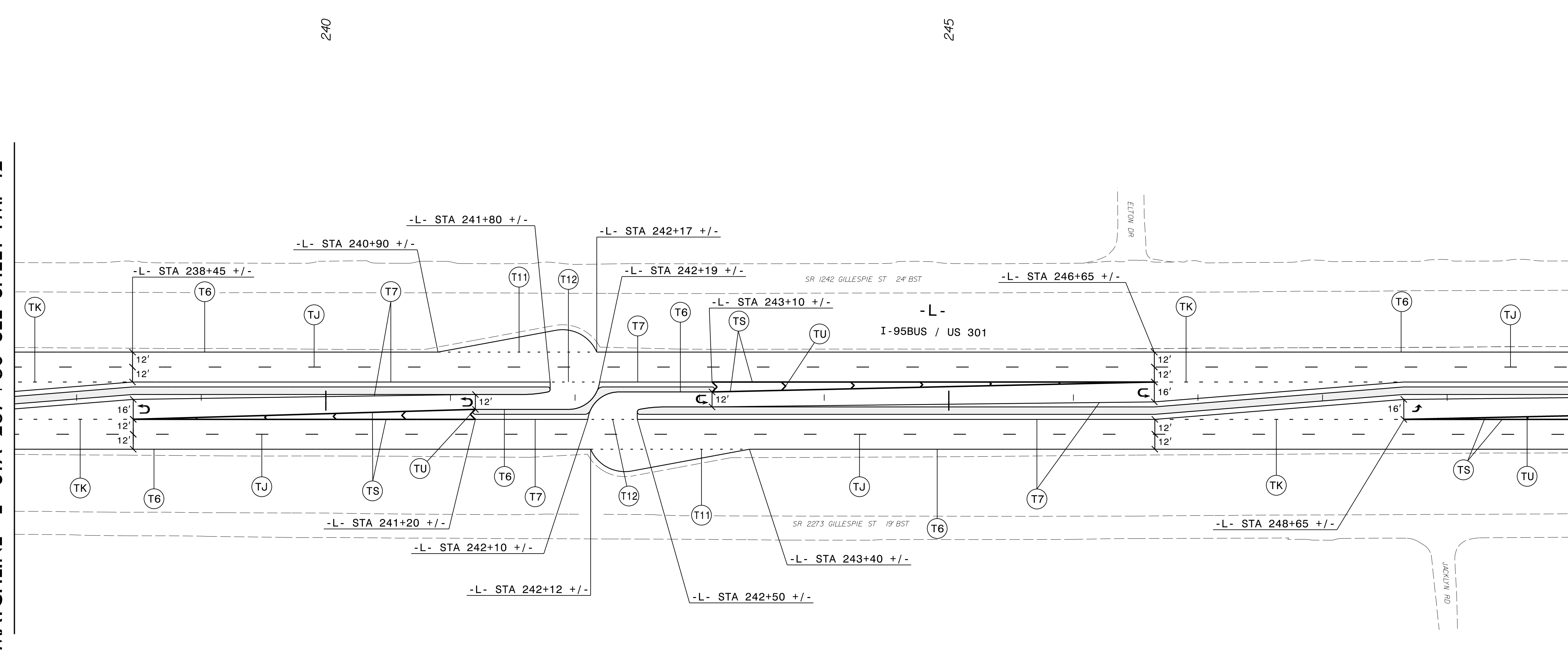

9/10/2015
 P:\8467\Cadd\W5519\Traffic\Signing\CADD\W-5519_pmp_pmp-13.dgn
 thufman

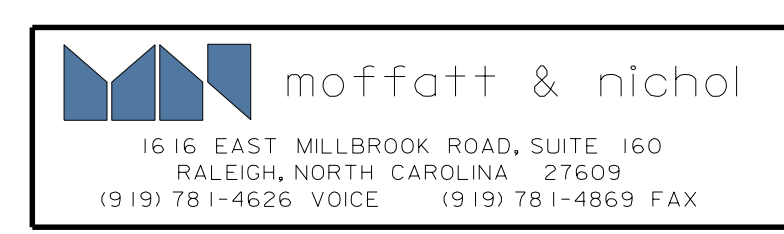

APPROVED: DATE: 9/10/2015

SEAL:

FINAL PAVEMENT MARKING PLANS

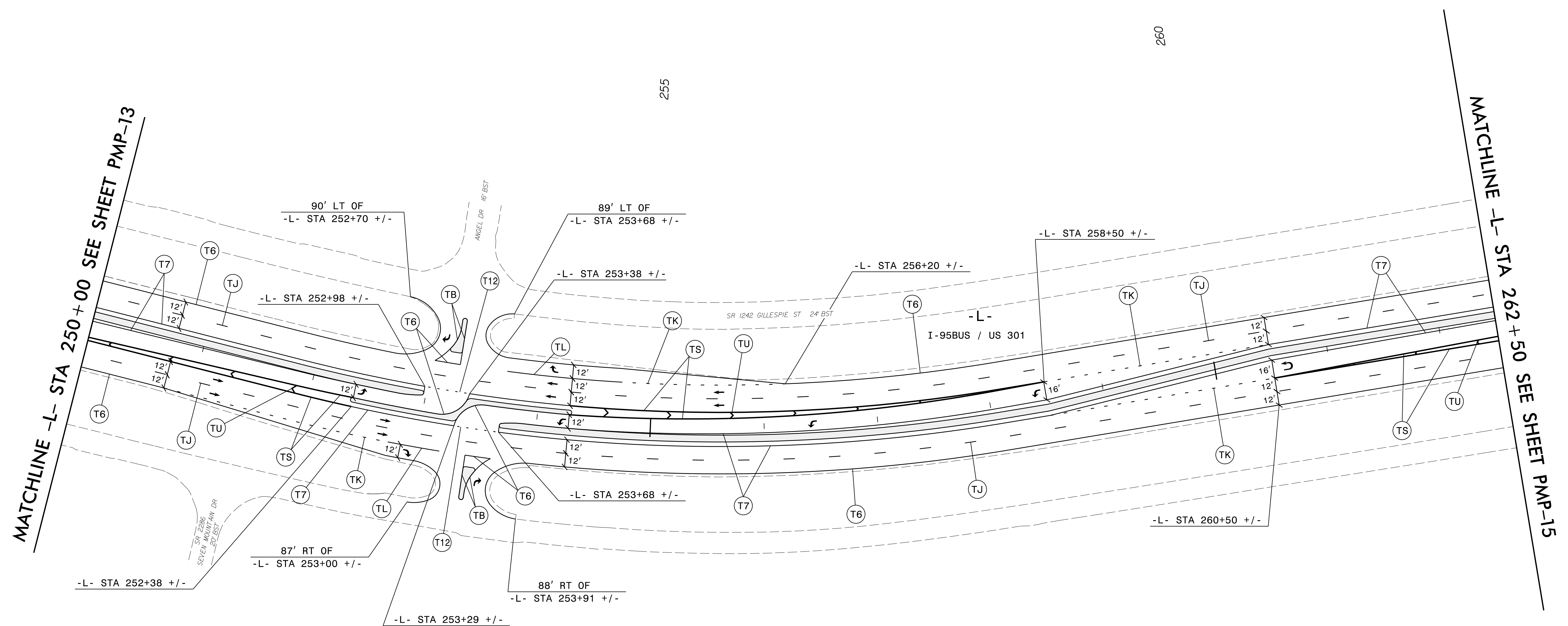
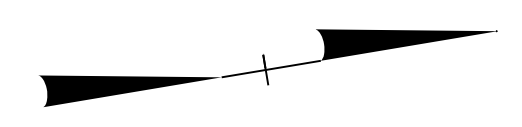

MATCHLINE -L- STA 250+00 SEE SHEET PMP-13

MATCHLINE -L- STA 262+50 SEE SHEET PMP-15

9/10/2015
 P:\8457\Cadd\W5519\Traffic\Signing\CADD\W5519_pmp-14.dgn
 thufman

mo moffatt & nichol
 1616 EAST MILLBROOK ROAD, SUITE 160
 RALEIGH, NORTH CAROLINA 27609
 (919) 781-4626 VOICE (919) 781-4869 FAX

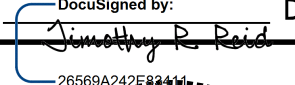
APPROVED:  DATE: 9/10/2015

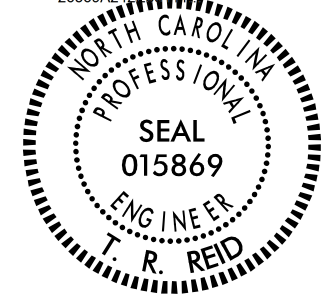
SEAL 

FINAL PAVEMENT MARKING PLANS

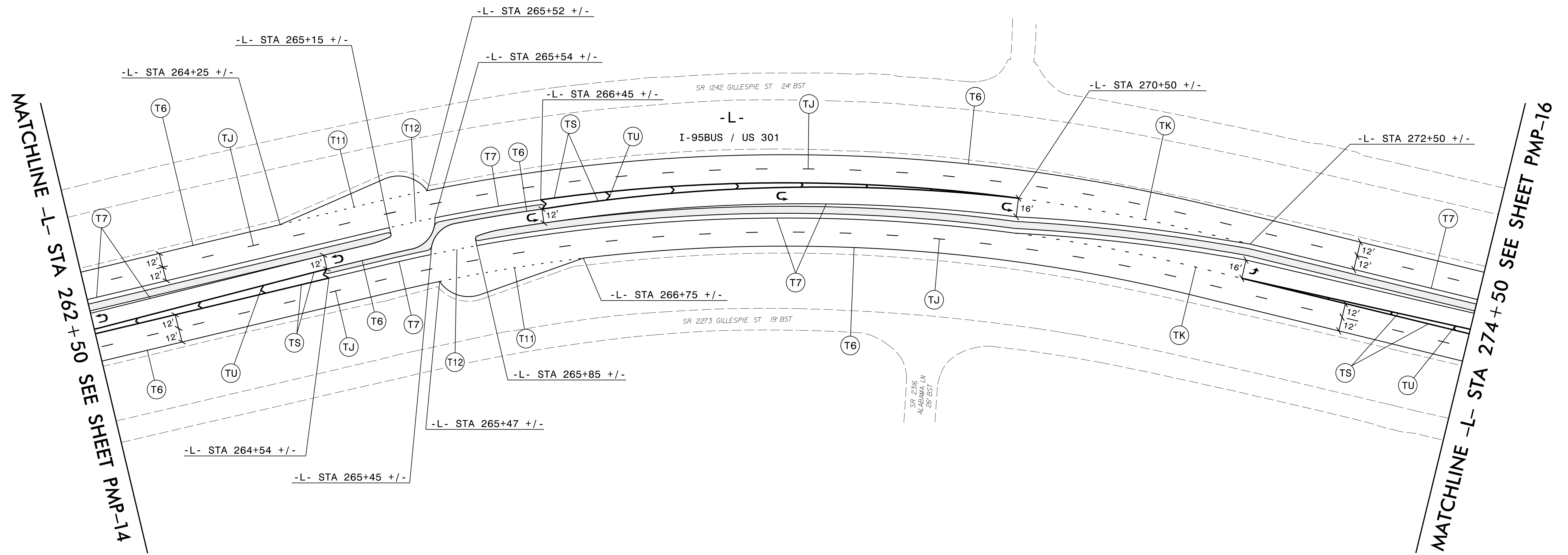
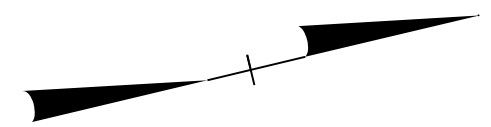

9/10/2015
 P:\8467\Cadd\W5519\Traffic\Signing\CADD\W5519_pmp-15.dgn
 thufman

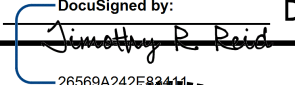

APPROVED:  DATE: 9/10/2015

SEAL

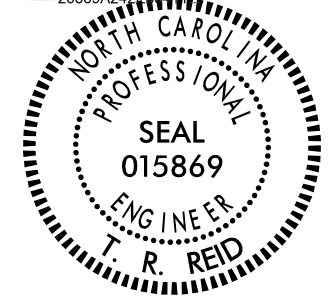

FINAL PAVEMENT MARKING PLANS

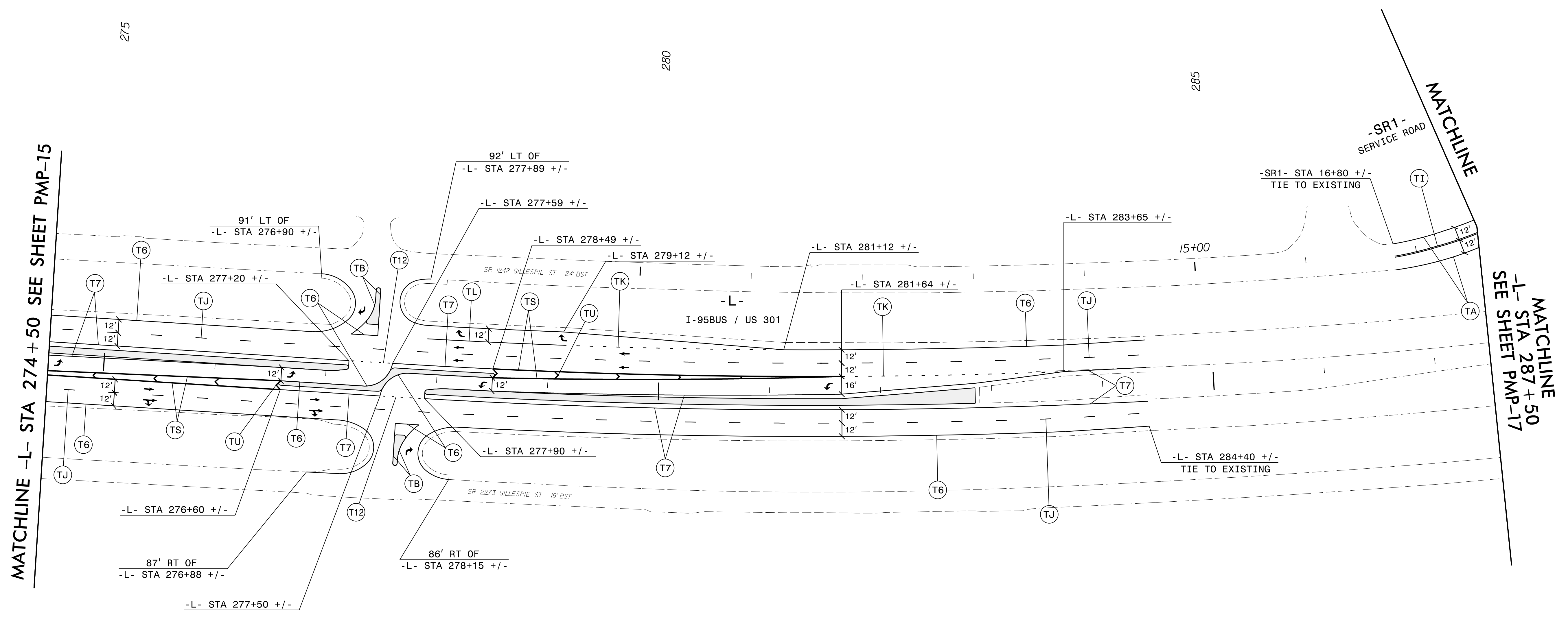
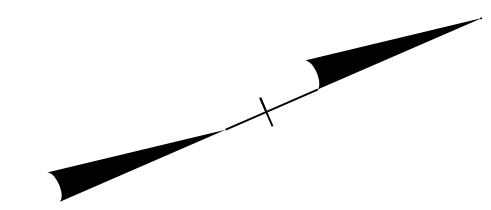

9/10/2015
 P:\8467\Cadd\W5519\Traffic\Signing\CADD\W5519_PMP_PMP-16.dgn
 THUFMAN

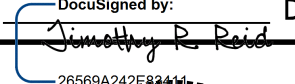
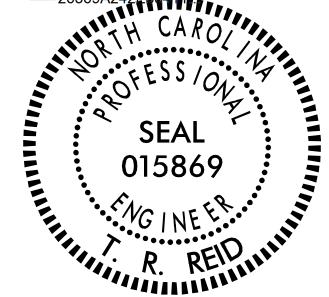

APPROVED:  DATE: 9/10/2015
 SEAL

FINAL PAVEMENT MARKING PLANS

PROJ. REFERENCE NO.	SHEET NO.
W-5519	PMP-17

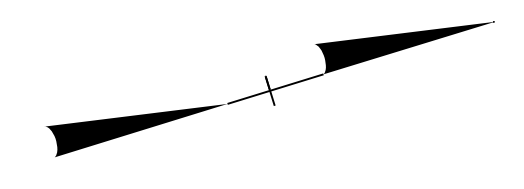
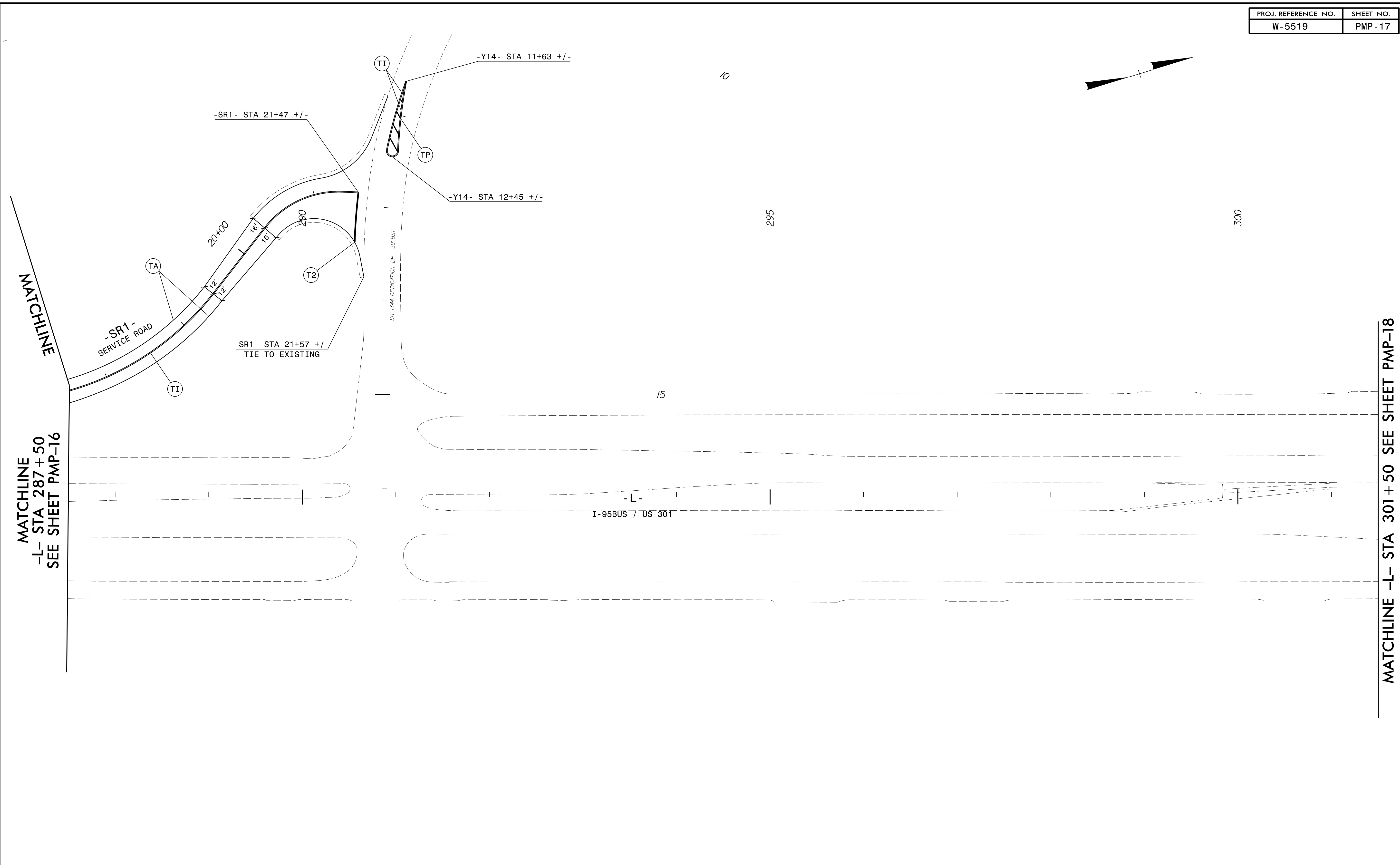

9/10/2015
 P:\8467\Cadd\W5519\Traffic\Signing\CADD\W5519_pmp-17.dgn
 T:\mfn

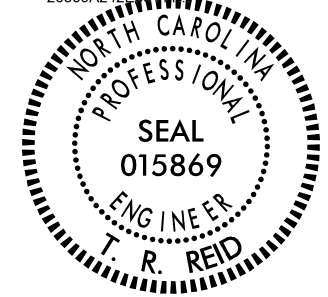

APPROVED: <i>Timothy R. Reid</i>	DATE: 9/10/2015
SEAL 	FINAL PAVEMENT MARKING PLANS

PROJ. REFERENCE NO.	SHEET NO.
W-5519	PMP-18

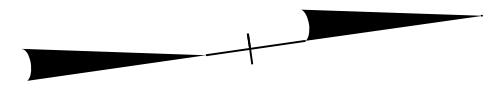

3/5

MATCHLINE -L- STA 301+50 SEE SHEET PMP-17

MATCHLINE -L- STA 315+50 SEE SHEET PMP-19

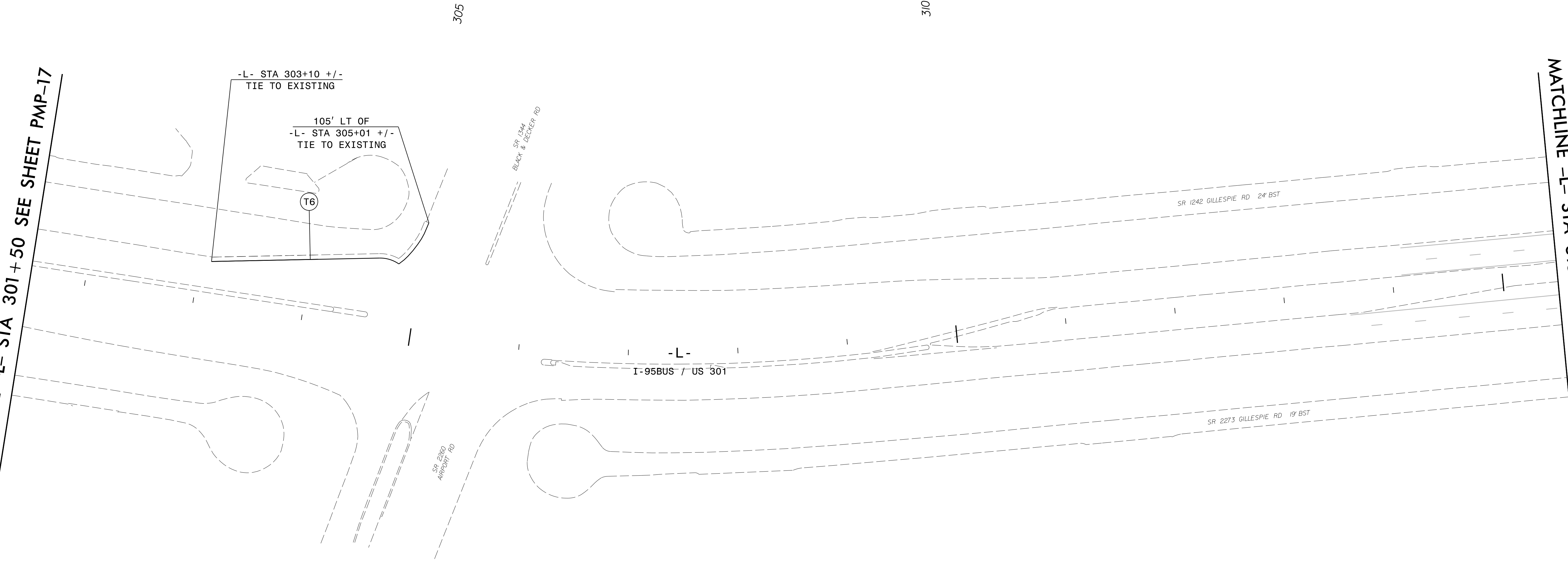
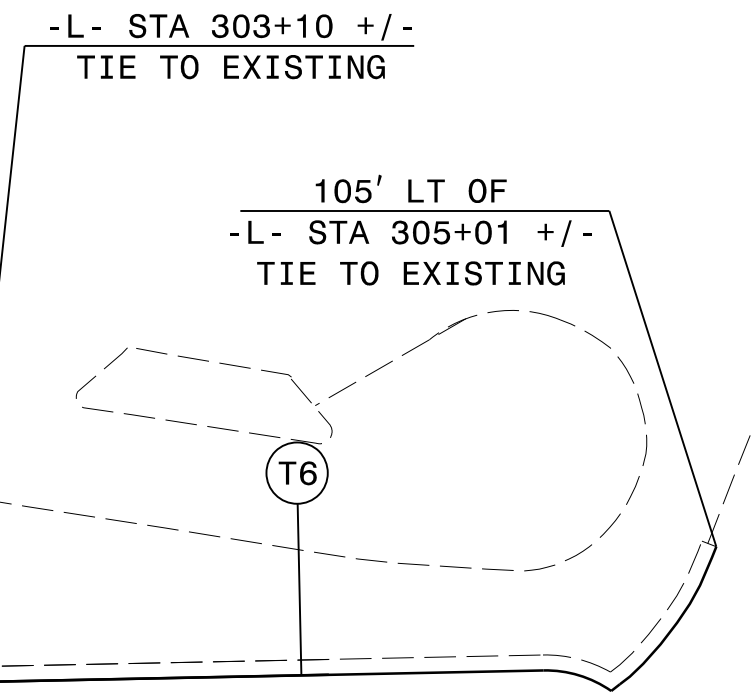

9/10/2015
P:\8457\Cadd\W5519\Traffic\Signing\CADD\W5519_PMP-18.dgn
THUFMAN

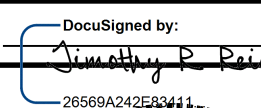

APPROVED:  DATE: 9/10/2015

SEAL

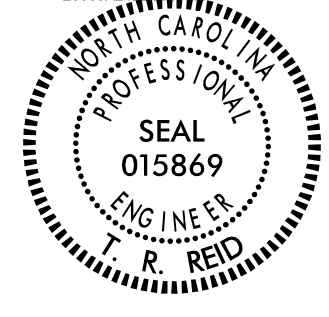

FINAL PAVEMENT MARKING PLANS

PROJ. REFERENCE NO.	SHEET NO.
W-5519	PMP-19

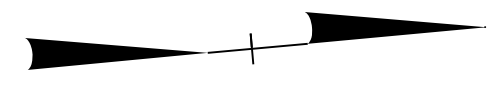

MATCHLINE -L- STA 315 + 50 SEE SHEET PMP-18

MATCHLINE -L- STA 328 + 50 SEE SHEET PMP-20

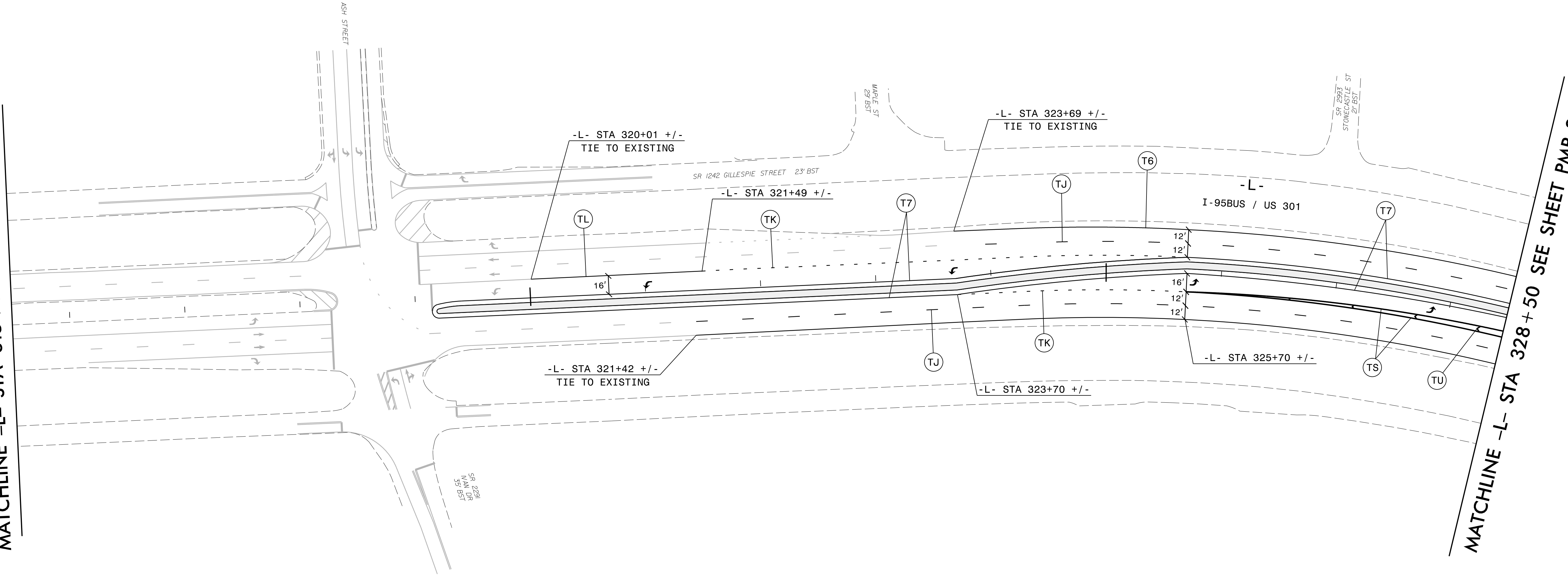

9/10/2015
P:\8467\Cadd\W5519\Traffic\Signing\CADD\W5519_pmp_pmp-19.dgn
THUFman

mo moffatt & nichol
1616 EAST MILLBROOK ROAD, SUITE 160
RALEIGH, NORTH CAROLINA 27609
(919) 781-4626 VOICE (919) 781-4869 FAX

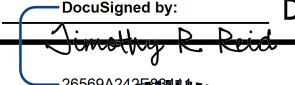
APPROVED:  DATE: 9/10/2015

SEAL: 

FINAL PAVEMENT MARKING PLANS

PROJ. REFERENCE NO.	SHEET NO.
W-5519	PMP-20

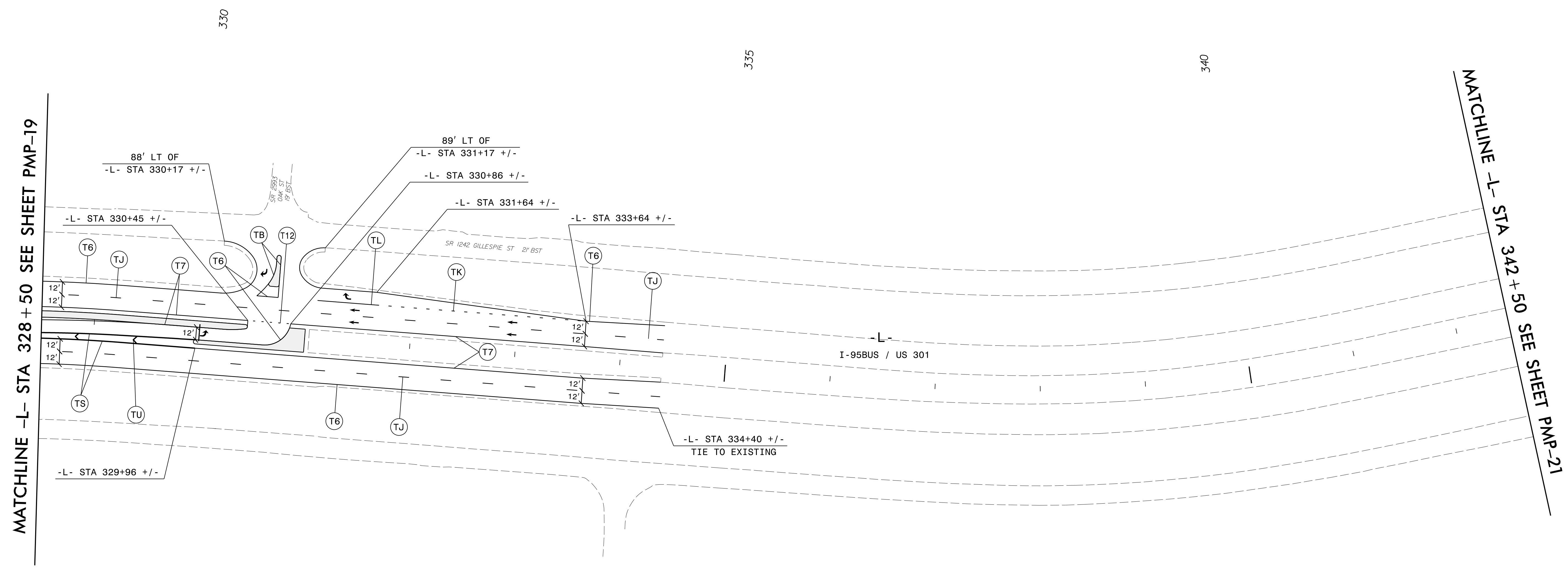
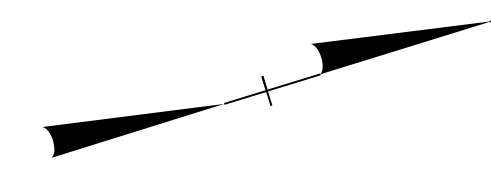

9/10/2015
 P:\8467\Cadd\W5519\Traffic\Signing\CADD\W5519_pmp-20.dgn
 thufman

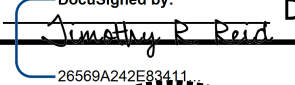

APPROVED:  DATE: 9/10/2015

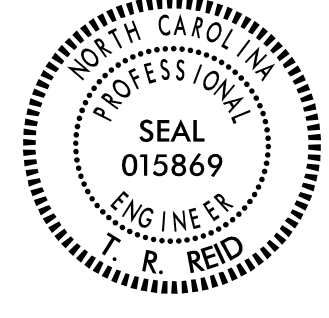
SEAL: 

FINAL PAVEMENT MARKING PLANS

PROJ. REFERENCE NO.	SHEET NO.
W-5519	PMP-21

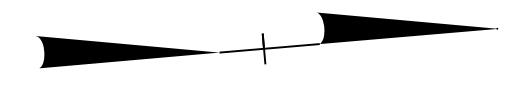

MATCHLINE -L- STA 342 + 50 SEE SHEET PMP-20

345

350

355

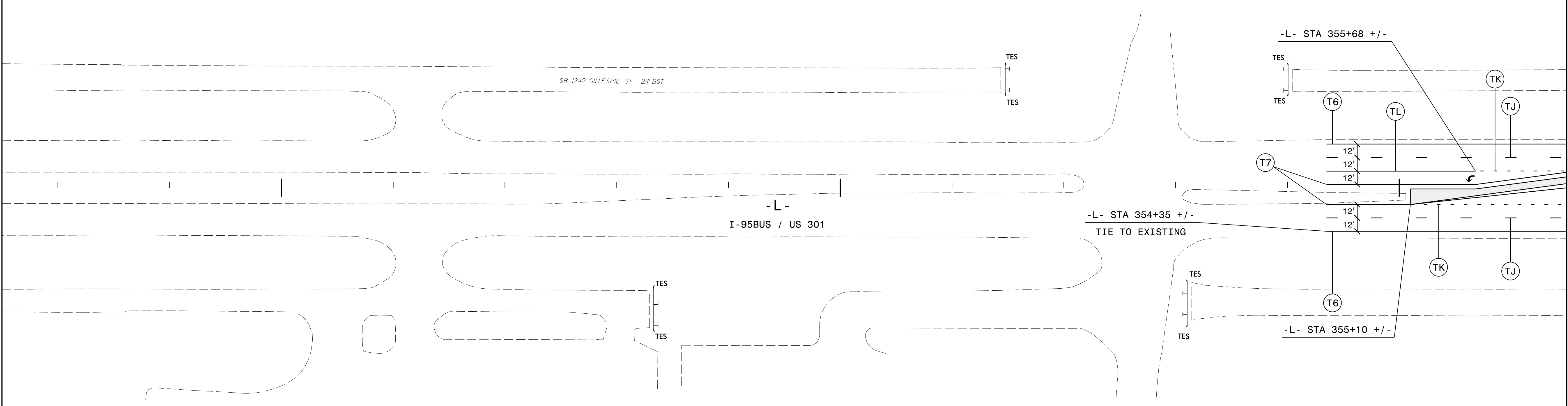

MATCHLINE -L- STA 356 + 50 SEE SHEET PMP-22

9/10/2015
 P:\8467\Cadd\W5519\Traffic\Signing\CADD\W5519_pmp-21.dgn
 thufman

mo moffatt & nichol
 1616 EAST MILLBROOK ROAD, SUITE 160
 RALEIGH, NORTH CAROLINA 27609
 (919) 781-4626 VOICE (919) 781-4869 FAX

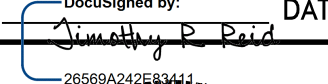
APPROVED:  DATE: 9/10/2015

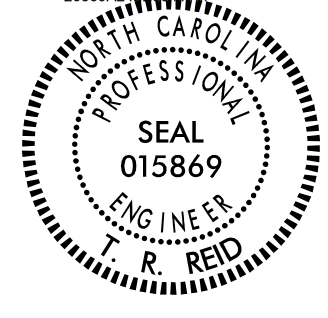
SEAL

FINAL PAVEMENT MARKING PLANS

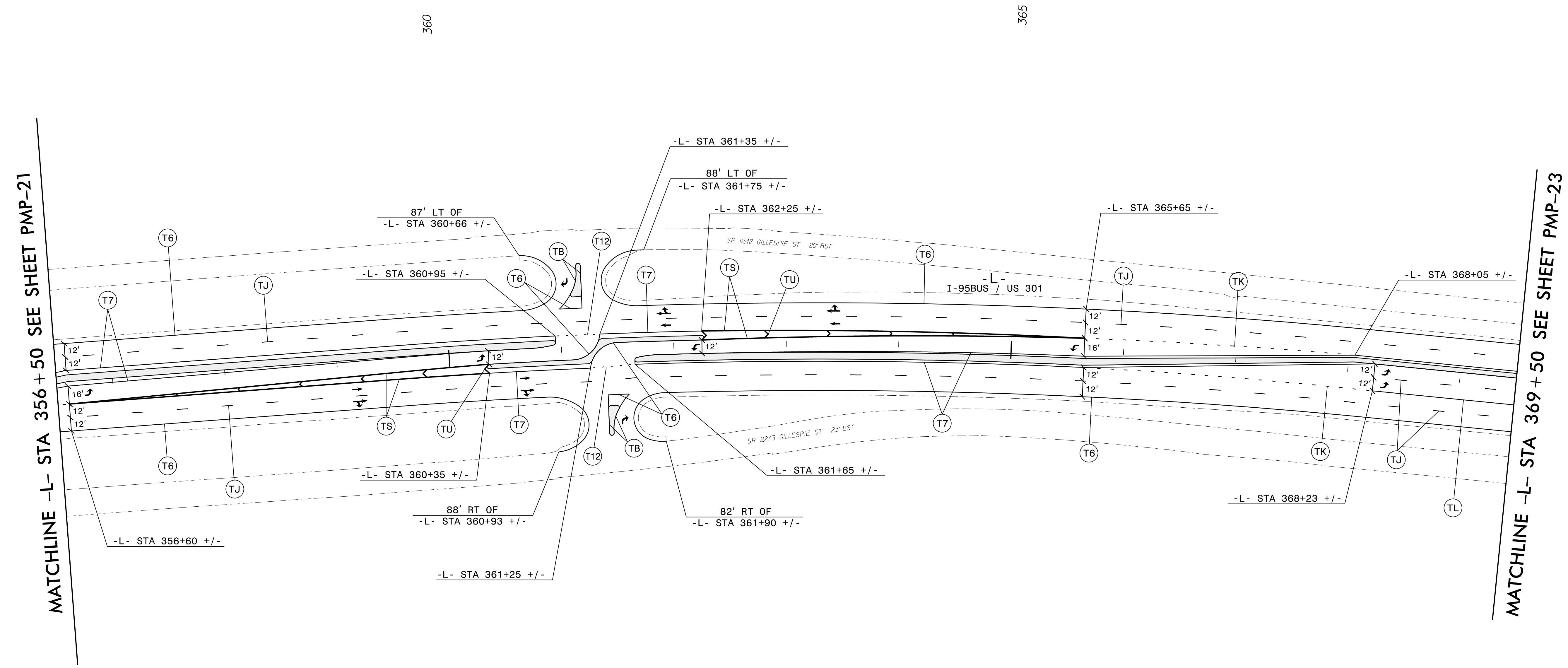
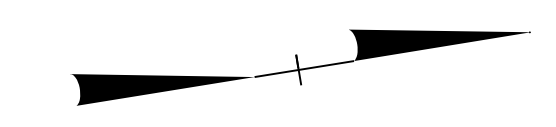

9/10/2015
 P:\8467\Cadd\W5519\Traffic\Signing\CADD\W5519_pmp-22.dgn
 thufman

moffatt & nichol
 1616 EAST MILLBROOK ROAD, SUITE 160
 RALEIGH, NORTH CAROLINA 27609
 (919) 781-4626 VOICE (919) 781-4869 FAX

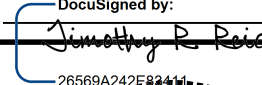
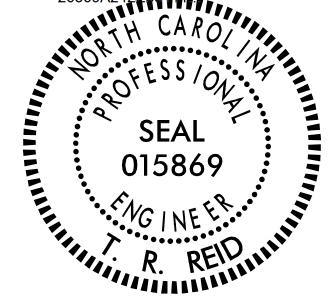
APPROVED:  DATE: 9/10/2015
 26660432

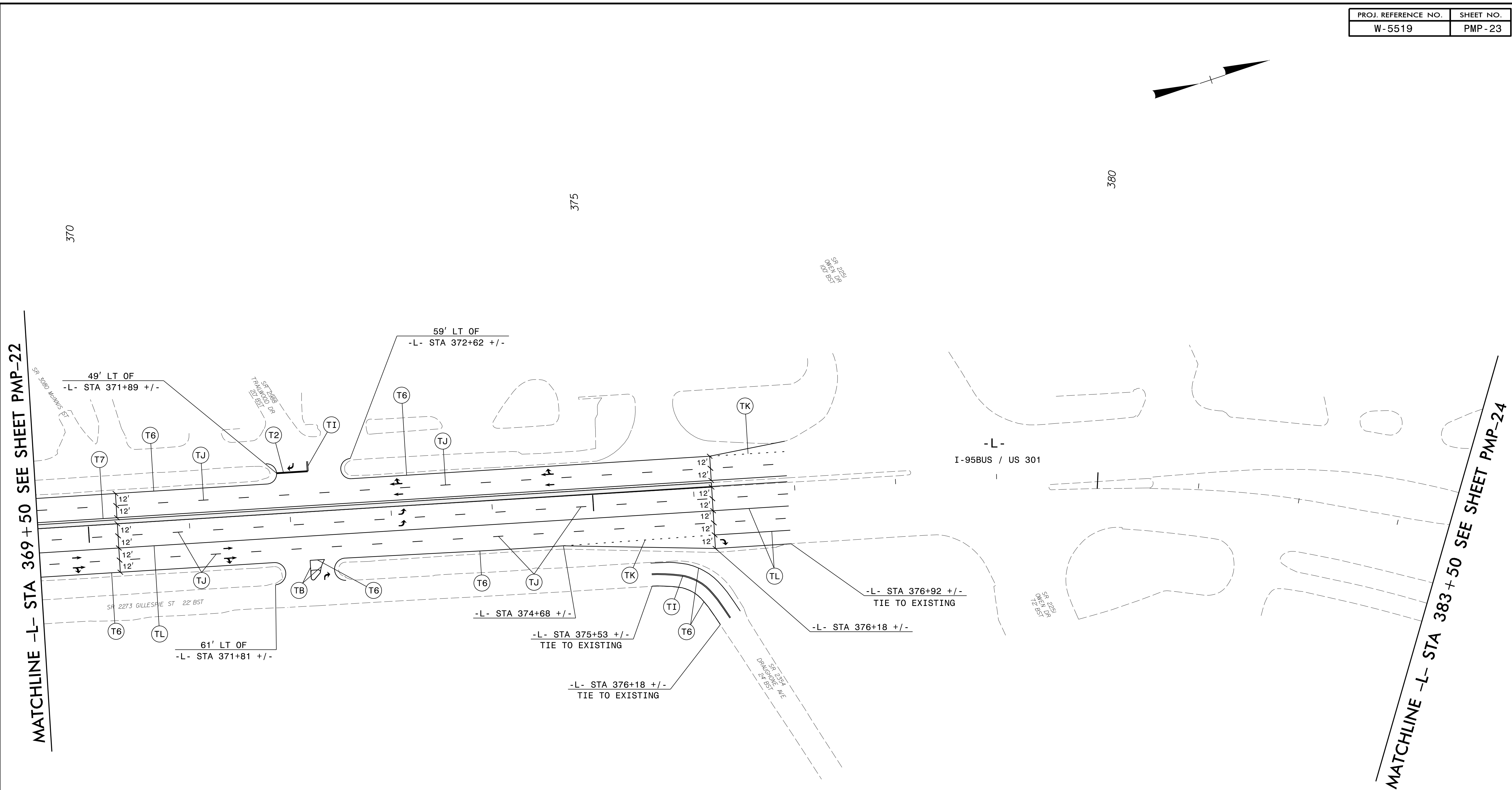
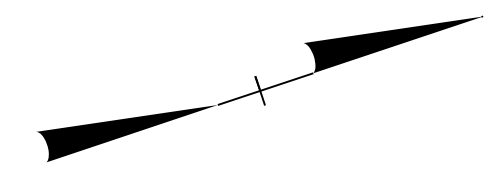

FINAL PAVEMENT
 MARKING PLANS

PROJ. REFERENCE NO.	SHEET NO.
W-5519	PMP-23

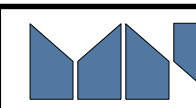

9/10/2015
 P:\8467\Cadd\W5519\Traffic\Signing\CADD\W5519_pmp-23.dgn
 thufman

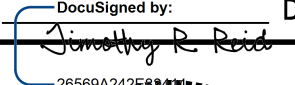
moffatt & nichol
 1616 EAST MILLBROOK ROAD, SUITE 160
 RALEIGH, NORTH CAROLINA 27609
 (919) 781-4626 VOICE (919) 781-4869 FAX

APPROVED:  DATE: 9/10/2015
 26560424

FINAL PAVEMENT
 MARKING PLANS

PROJ. REFERENCE NO.	SHEET NO.
W-5519	PMP-24

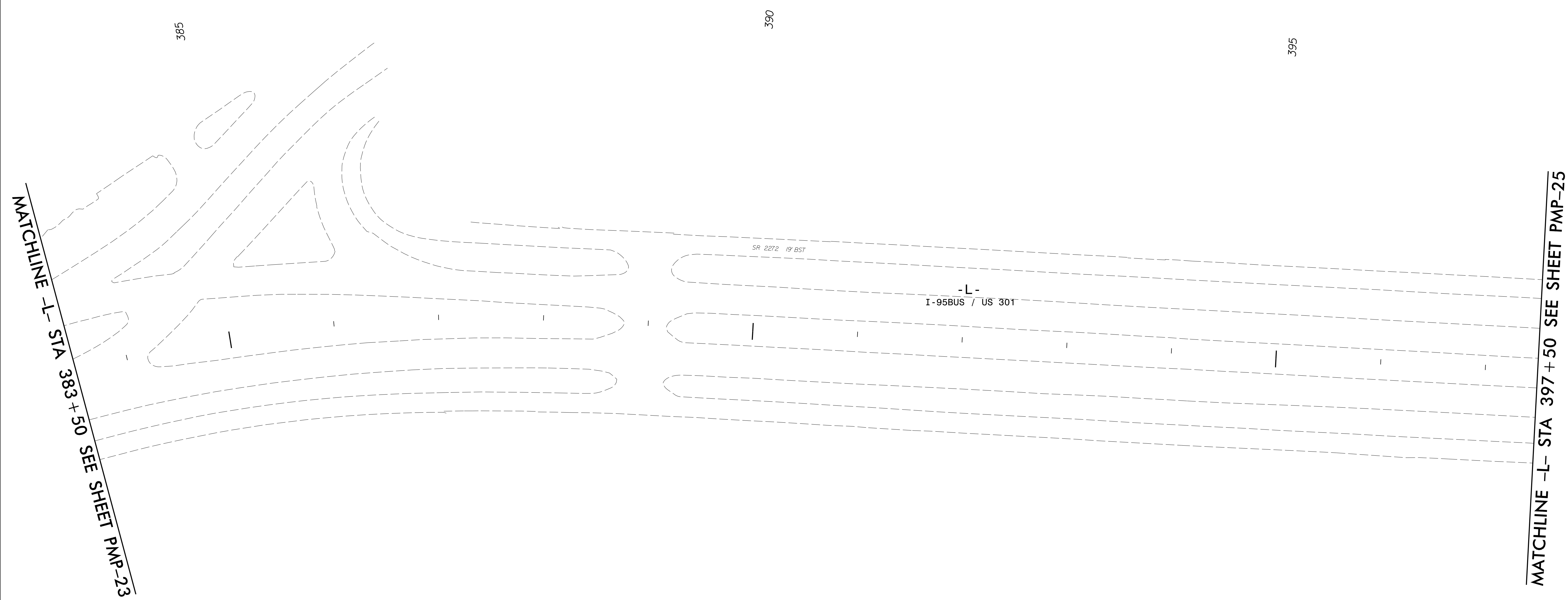
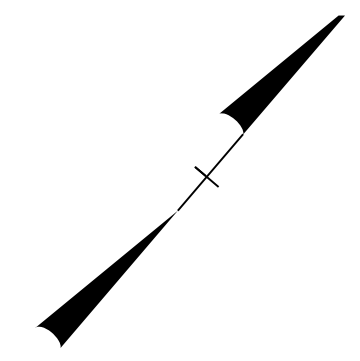

****NO WORK THIS SHEET****

9/10/2015
 P:\8467\Cadd\W5519\Traffic\Signing\CADD\W5519_pmp-24.dgn
 thuffman

moffatt & nichol
 1616 EAST MILLBROOK ROAD, SUITE 160
 RALEIGH, NORTH CAROLINA 27609
 (919) 781-4626 VOICE (919) 781-4869 FAX

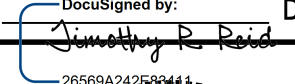
APPROVED:  DATE: 9/10/2015

SEAL

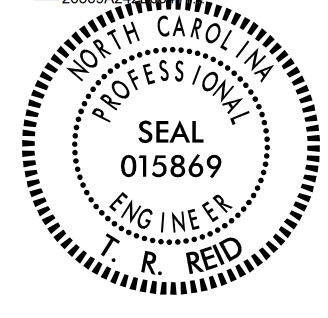

FINAL PAVEMENT MARKING PLANS

PROJ. REFERENCE NO.	SHEET NO.
W-5519	PMP-25

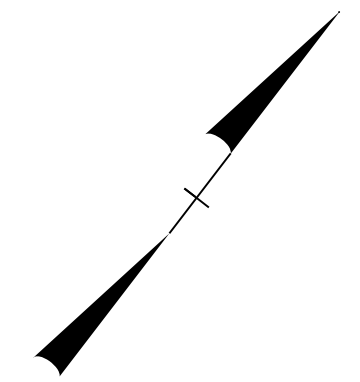

MATCHLINE -L- STA 397 + 50 SEE SHEET PMP-24

MATCHLINE -L- STA 411 + 50 SEE SHEET PMP-26

400

405

410

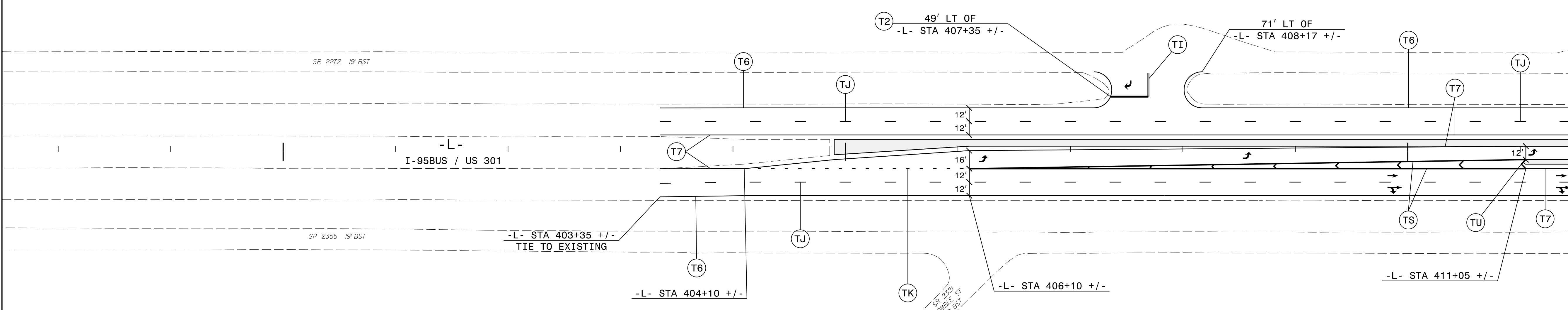

9/10/2015
P:\8467\Cadd\W5519\Traffic\Signing\CADD\W5519_pmp_pmp-25.dgn
THUF:man

mo moffatt & nichol
1616 EAST MILLBROOK ROAD, SUITE 160
RALEIGH, NORTH CAROLINA 27609
(919) 781-4626 VOICE (919) 781-4869 FAX

APPROVED: DATE: 9/10/2015

SEAL

FINAL PAVEMENT MARKING PLANS

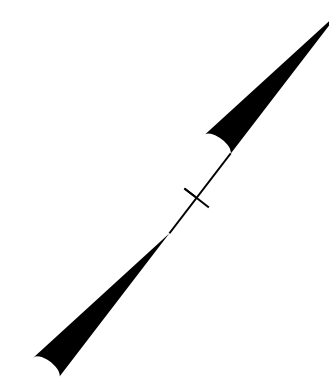

MATCHLINE -L- STA 411 + 50 SEE SHEET PMP-25

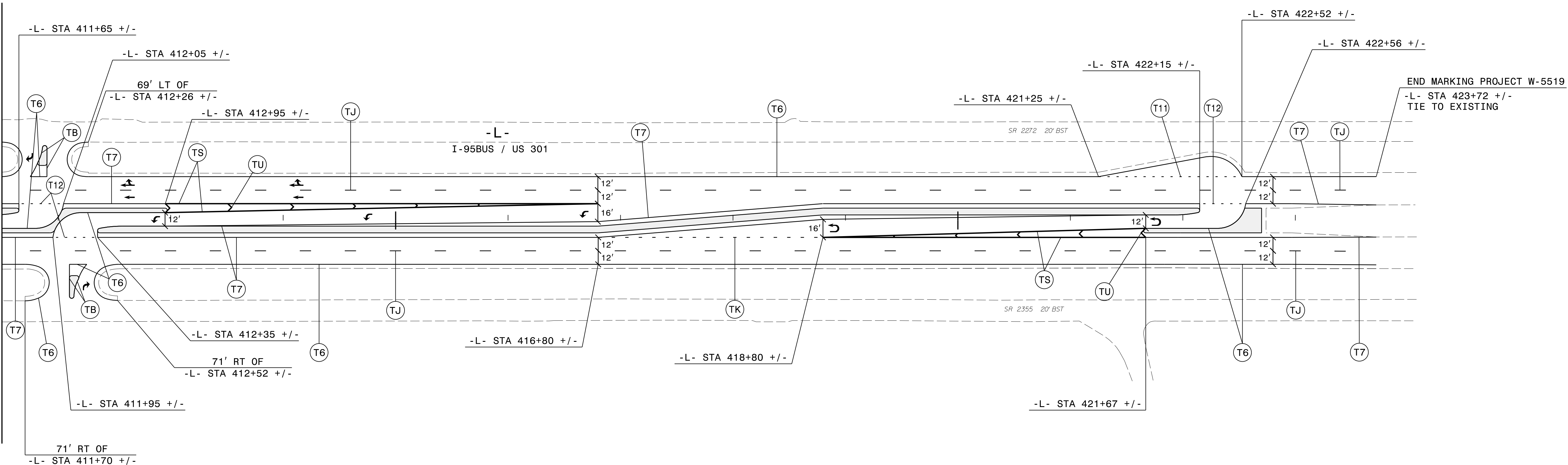

9/10/2015
P:\8457\Cadd\W5519\Traffic\Signing\CADD\W5519_PMP-26.dgn
THUFMAN

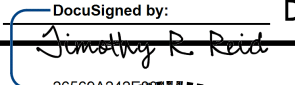

APPROVED:  DATE: 9/10/2015

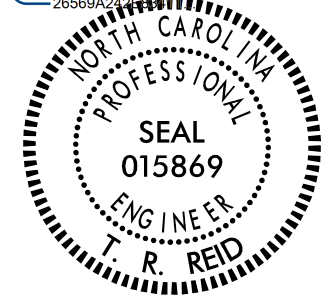
SEAL: 

FINAL PAVEMENT MARKING PLANS