

NOTES

- STIRRUPS IN CAP MAY BE SHIFTED AS NECESSARY TO CLEAR DOWELS.
- ★ INVERT ALTERNATE STIRRUPS.
- GALVANIZE THE TOP OF EACH INTERIOR BENT PILE A MINIMUM OF 40 FEET. GALVANIZE IN ACCORDANCE WITH SECTION 1076 OF THE STANDARD SPECIFICATIONS.

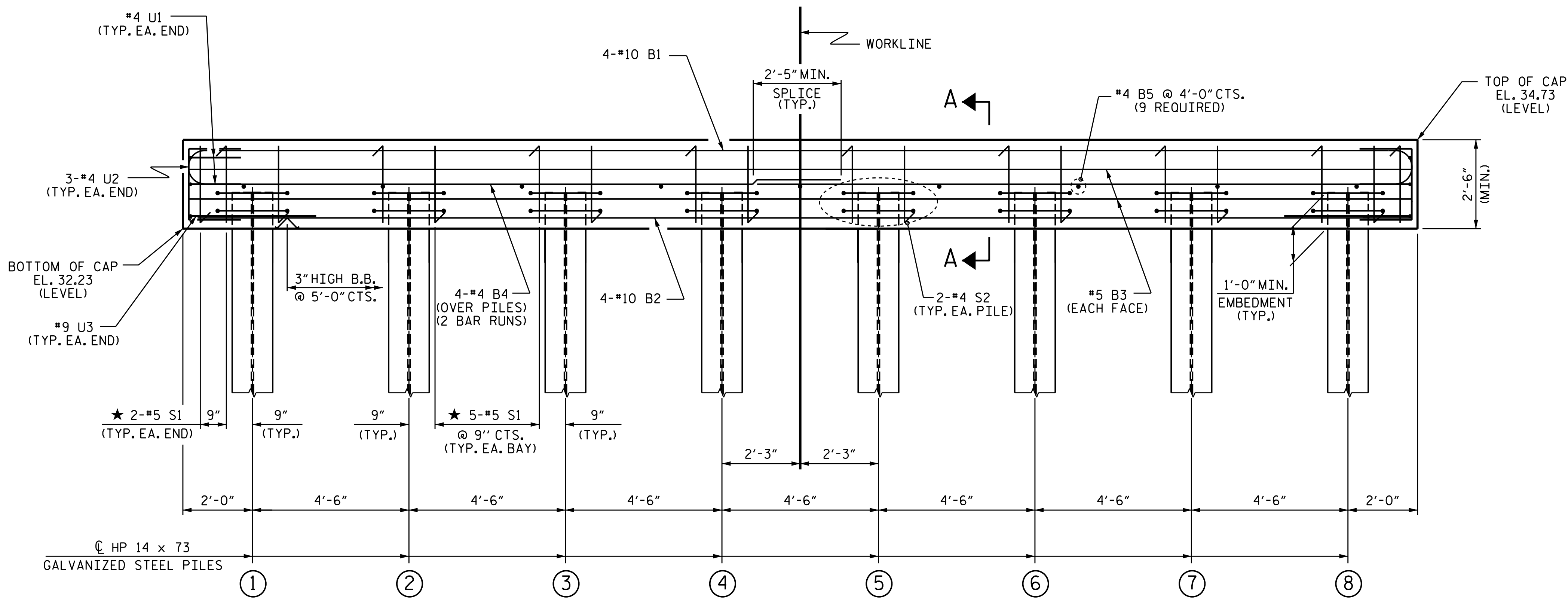
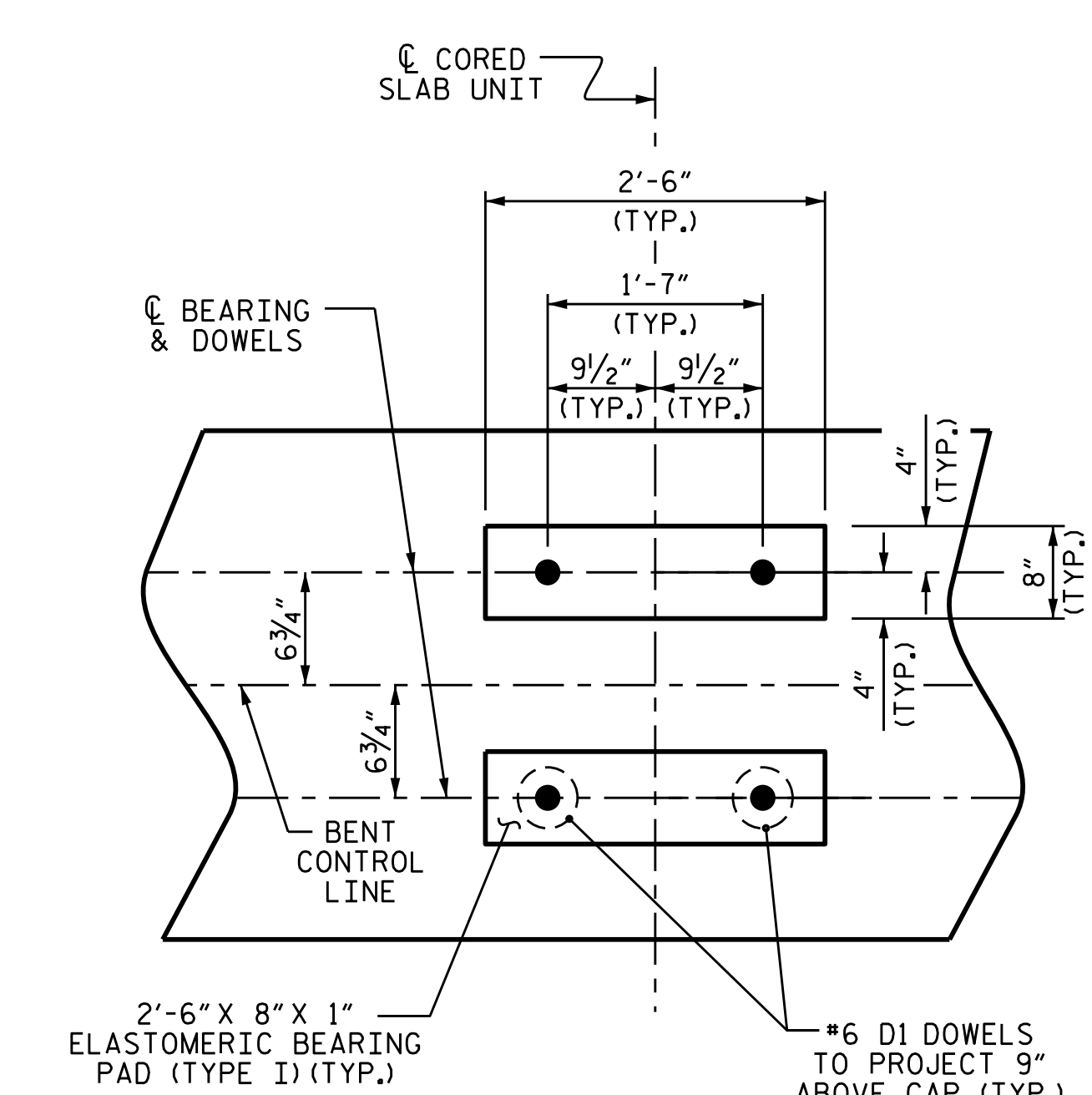
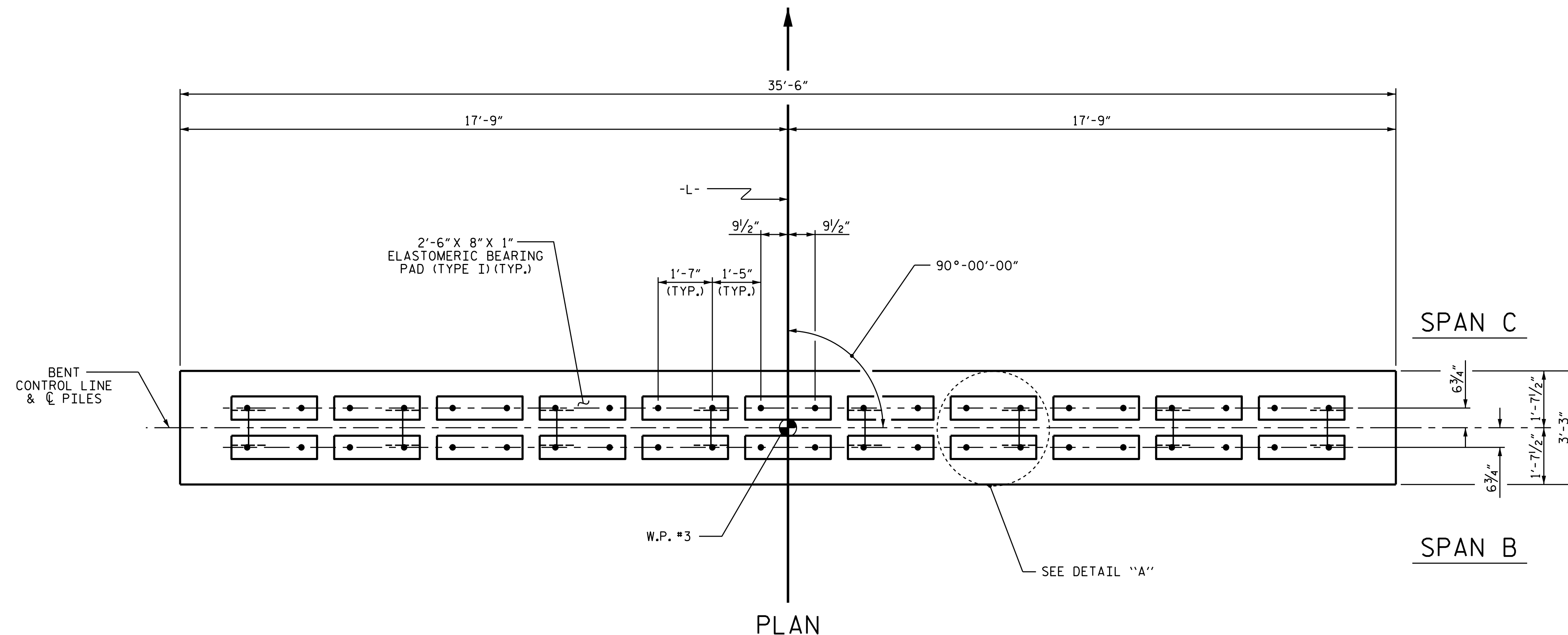

PROJECT NO. B-5331
COLUMBUS COUNTY
 STATION: 15+20.00 -L-

SHEET 2 OF 3

STATE OF NORTH CAROLINA
 DEPARTMENT OF TRANSPORTATION
 RALEIGH

SUBSTRUCTURE
 BENT 2

REVISIONS						SHEET NO.	
NO.	BY:	DATE:	NO.	BY:	DATE:	S-15	
1			3			TOTAL SHEETS 18	
2			4				

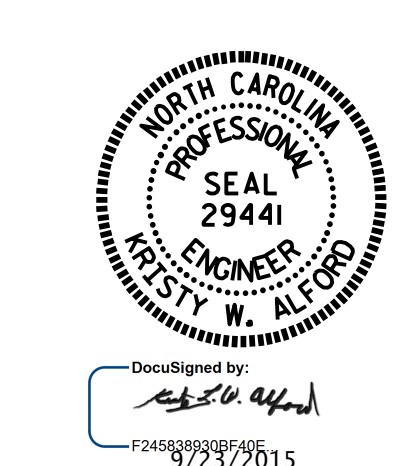

ASSEMBLED BY : D. SHACKELFORD	DATE : 01/15
CHECKED BY : J.P. ADAMS	DATE : 02/15
DRAWN BY : DGE	05/10
CHECKED BY : MKT	05/10
REV. 11/14	MAA/TMG

23-SEP-2015 09:26
 R:\Structures\Plans\Sub.Draw\B-5331.SD.B*.dgn
 jpodams