

**NOTES**

STIRRUPS IN CAP MAY BE SHIFTED AS NECESSARY TO CLEAR DOWELS.

THE CONCRETE IN THE SHADED AREA OF THE WING SHALL BE POURED AFTER THE VERTICAL CONCRETE BARRIER RAIL IS CAST IF SLIP FORMING IS USED.

FOR PILE SPLICE DETAILS, SEE SHEET 4 OF 4.

FOR WING DETAILS, SEE SHEET 3 OF 4.

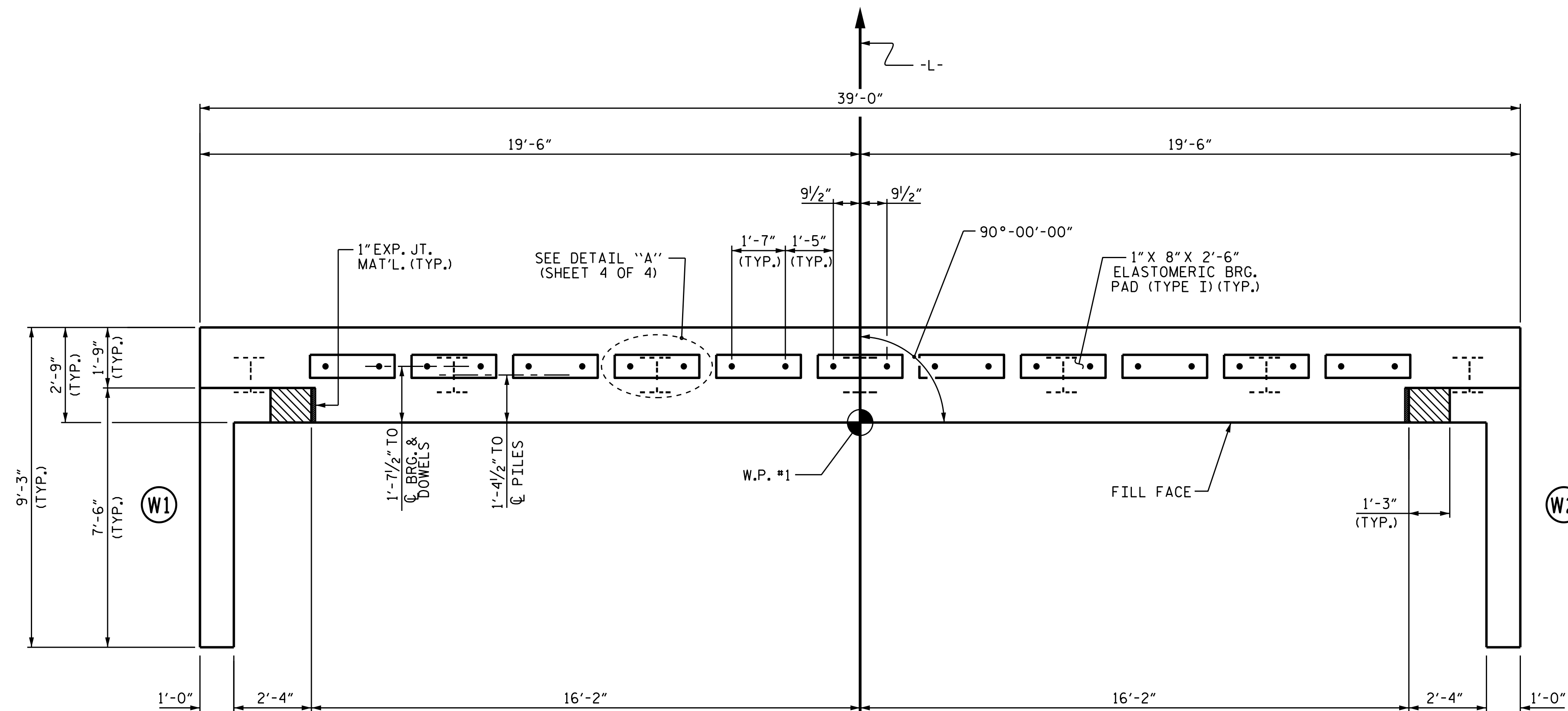

**PLAN**

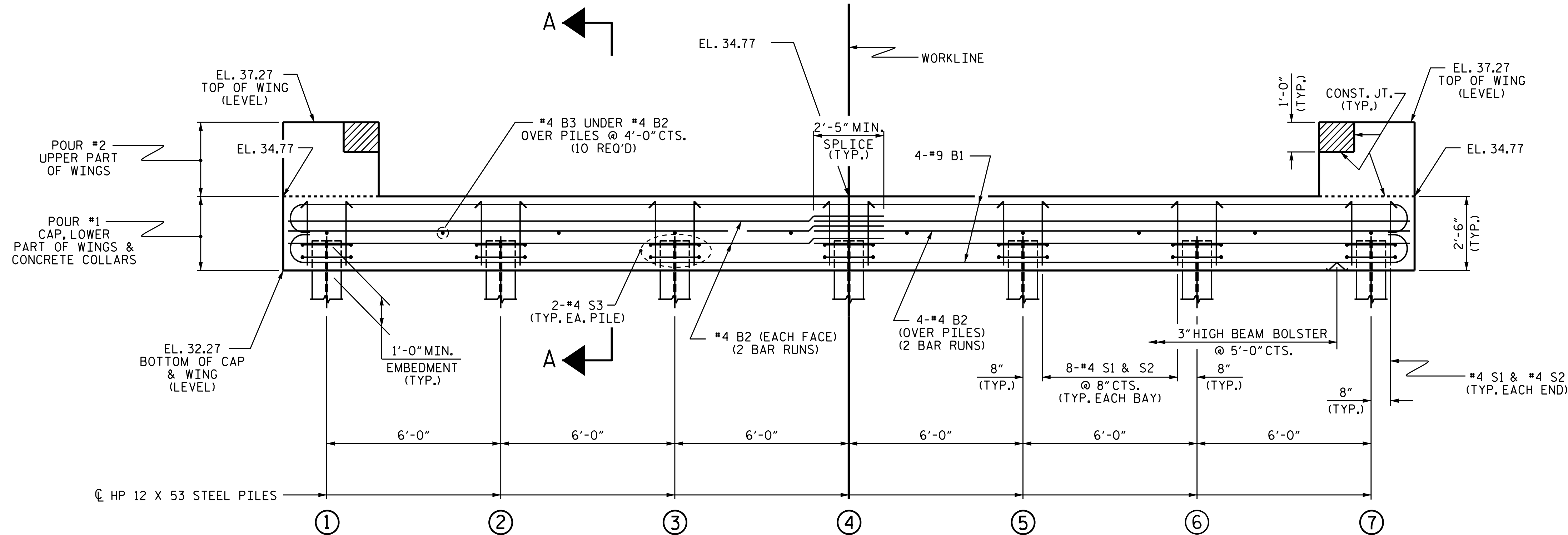

**ELEVATION**

WINGS NOT SHOWN FOR CLARITY.  
FOR SECTION A-A, SEE SHEET 4 OF 4.  
CONCRETE COLLARS FOR STEEL PILES NOT SHOWN IN PLAN AND ELEVATION VIEWS FOR CLARITY.  
SEE "CORROSION PROTECTION FOR STEEL PILES DETAIL", SHEET 4 OF 4.

PROJECT NO. B-5331  
COLUMBUS COUNTY  
STATION: 15+20.00 -L-

SHEET 1 OF 4



|  |     |       |     |     |                    |
|--|-----|-------|-----|-----|--------------------|
| STATE OF NORTH CAROLINA<br>DEPARTMENT OF TRANSPORTATION<br>RALEIGH |     |       |     |     |                    |
| SUBSTRUCTURE<br>END BENT 1   |     |       |     |     |                    |
| REVISIONS  |     |       |     |     |                    |
| NO.  | BY: | DATE: | NO. | BY: | DATE:              |
| 1  |     |       | 3   |     |                    |
| 2  |     |       | 4   |     |                    |
|  |     |       |     |     | SHEET NO.<br>S-10  |
|  |     |       |     |     | TOTAL SHEETS<br>18 |

|                               |              |
|-------------------------------|--------------|
| ASSEMBLED BY : D. SHACKELFORD | DATE : 01/15 |
| CHECKED BY : J.P. ADAMS       | DATE : 02/15 |
| DRAWN BY : DGE                | 01/10        |
| CHECKED BY : MKT              | 01/10        |
| REV. 4/15                     | MAA/TMG      |