

### TYPICAL MICROWAVE DETECTOR WIRING DETAIL

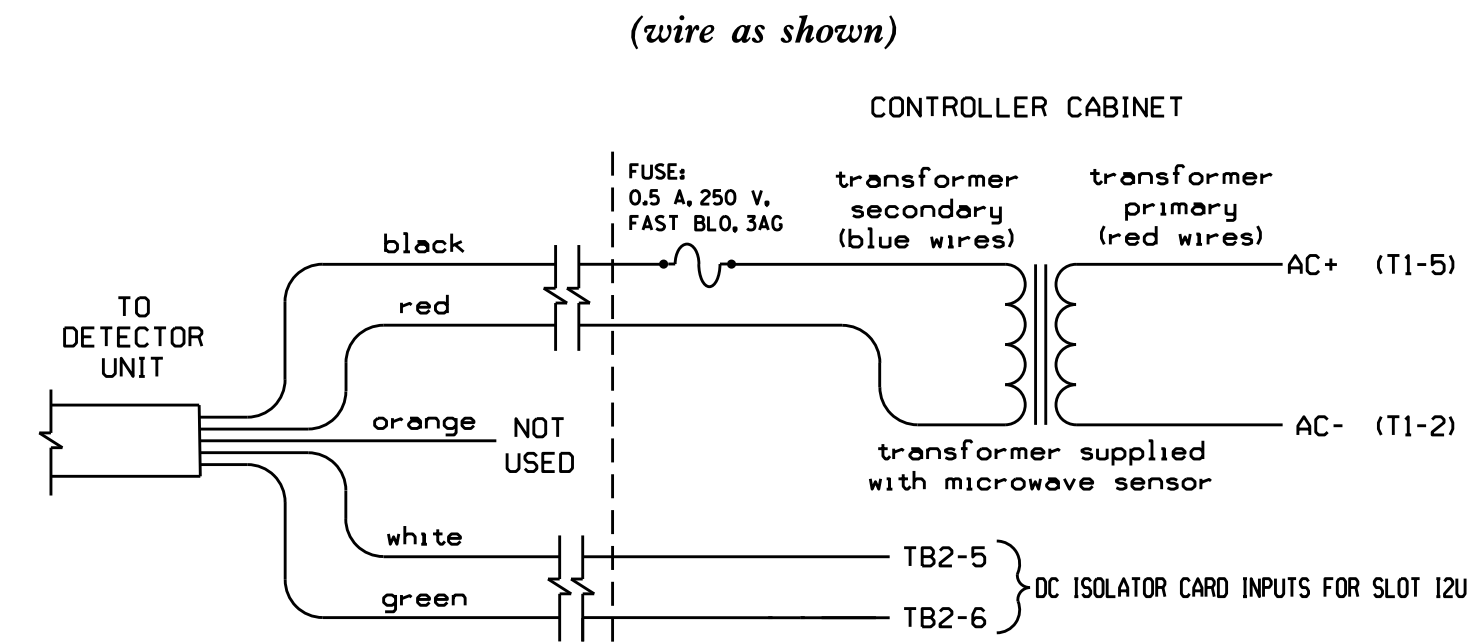

TC26B WIRE LIST

COLOR	FUNCTION
black	12V to 24V AC/DC (no polarity)
red	12V to 24V AC/DC (no polarity)
orange	Output Relay Normally Open
white	Output Relay Normally Closed
green	Output Relay Common

NOTES:

- Sensor is microwave motion detector mounted on a pole as indicated on the Signal Design Plans.
- Microwave wiring shown above will cause a permanent call unless the Input Assignment Programming and Logical I/O Processor Programming details are entered as shown on this sheet. These programming details will cause a call to be placed upon opening the Normally Closed contact on the microwave detector.
- DC Isolator's LED will be ON when no call is present and will be OFF when a call is present.
- Important: For proper operation of the microwave detector, remove surge protection from TB2-5, TB2-6, TB2-7, and TB2-8 and insert 242 DC Isolator in slot 12.

### INPUT ASSIGNMENT PROGRAMMING DETAIL FOR MICROWAVE DETECTOR INPUT

(program controller as shown below)

FROM MAIN MENU PRESS '5' (INPUTS), THEN '+' UNTIL INPUT 1 (PIN 39) IS REACHED. MODIFY DEFAULT CONDITIONS AS INDICATED BY ARROWS.

```

PAGE: 1 C1 PIN:39 NOT ENABLED
INPUT ASSIGNMENT #.....1
DEBOUNCE TIME (0-25.5 SEC).....0.5
DELAY TIME (0-25.5 SEC).....0.0
HOLD-OVER TIME (0-25.5 SEC).....0.0
ASSIGNMENT SELECTION:
NOT ENABLED (Y/N).....Y
VEHICLE DETECTOR (1-64).....-
PEDESTRIAN DETECTOR (1-16).....-
ALTERNATE PED DETECTOR (1-16).....-
PREEMPT (1-10).....-
INVERTED PREEMPT (1-10).....-
STOP TIME (Y/N).....-
FLASH SENSE (Y/N).....-
DOOR OPEN (Y/N).....-
MANUAL CONTROL ENABLE (Y/N).....-
MANUAL CONTROL ADVANCE (Y/N).....-
SPECIAL FUNCTION ALARM (1-8).....-
TOD HOUR SYNCHRONIZATION (0-23).....-
FORCE OFF RING (1-4).....-
HOLD PHASES (1-16).....-
PLAN (65=FLSH,66=FREE)... OFFSET#...
CHANGE PHASE SEQUENCE PAGE (1-12)...
CHANGE PHASE TIMING PAGE (1-4).....
CHANGE PHASE CONTROL PAGE (1-4).....
CHANGE OVERLAP CONTROL PAGE (1-4)...
CHANGE INPUT PAGE (1-4).....
CHANGE OUTPUT PAGE (1-4).....
OVERRIDE PHASE CONTROL FUNCTION (Y)...
    
```

ENTER 'YES' for Not Enabled

```

PAGE: 1 C1 PIN:0 VEHICLE DETECTOR
INPUT ASSIGNMENT #.....64
DEBOUNCE TIME (0-25.5 SEC).....0.5
DELAY TIME (0-25.5 SEC).....0.0
HOLD-OVER TIME (0-25.5 SEC).....0.0
ASSIGNMENT SELECTION:
NOT ENABLED (Y/N).....-
VEHICLE DETECTOR (1-64).....2
PEDESTRIAN DETECTOR (1-16).....-
ALTERNATE PED DETECTOR (1-16).....-
PREEMPT (1-10).....-
INVERTED PREEMPT (1-10).....-
STOP TIME (Y/N).....-
FLASH SENSE (Y/N).....-
DOOR OPEN (Y/N).....-
MANUAL CONTROL ENABLE (Y/N).....-
MANUAL CONTROL ADVANCE (Y/N).....-
SPECIAL FUNCTION ALARM (1-8).....-
TOD HOUR SYNCHRONIZATION (0-23).....-
FORCE OFF RING (1-4).....-
HOLD PHASES (1-16).....-
PLAN (65=FLSH,66=FREE)...65 OFFSET#...
CHANGE PHASE SEQUENCE PAGE (1-12)...
CHANGE PHASE TIMING PAGE (1-4).....
CHANGE PHASE CONTROL PAGE (1-4).....
CHANGE OVERLAP CONTROL PAGE (1-4)...
CHANGE INPUT PAGE (1-4).....
CHANGE OUTPUT PAGE (1-4).....
OVERRIDE PHASE CONTROL FUNCTION (Y)...
    
```

ENTER '2' for Vehicle Detector

THIS ELECTRICAL DETAIL IS FOR THE SIGNAL DESIGN: 07-1623  
DESIGNED: April 2014  
SEALED: 3/26/2015  
REVISED: N/A

PRESS '-' until Input Assignment #64 is reached

PROGRAMMING COMPLETE

NOTE:

This remapping removes the default detector from the microwave's physical input and reassigns it to unused INPUT 64. The Logical I/O Processor Programming Detail ( commands 4 and 5 ) on sheet 2 will invert the disabled input and control INPUT 64 and the reassigned detector.

Electrical Detail - Sheet 3 of 3

ELECTRICAL AND PROGRAMMING DETAILS FOR: Prepared In the Offices of:  750 N. Greenfield Pkwy, Garner, NC 27529	NC 68 (Eastchester Drive) at I-74 WB/US 311 NB Ramps		SEAL  SEAL 022013 ENGINEER GEORGE C. BROWN
	Division 7 PLAN DATE: June 2014 PREPARED BY: C. Strickland	Guilford County High Point REVIEWED BY: T. Joyce REVIEWED BY:	