

TYPICAL MICROWAVE DETECTOR WIRING DETAIL

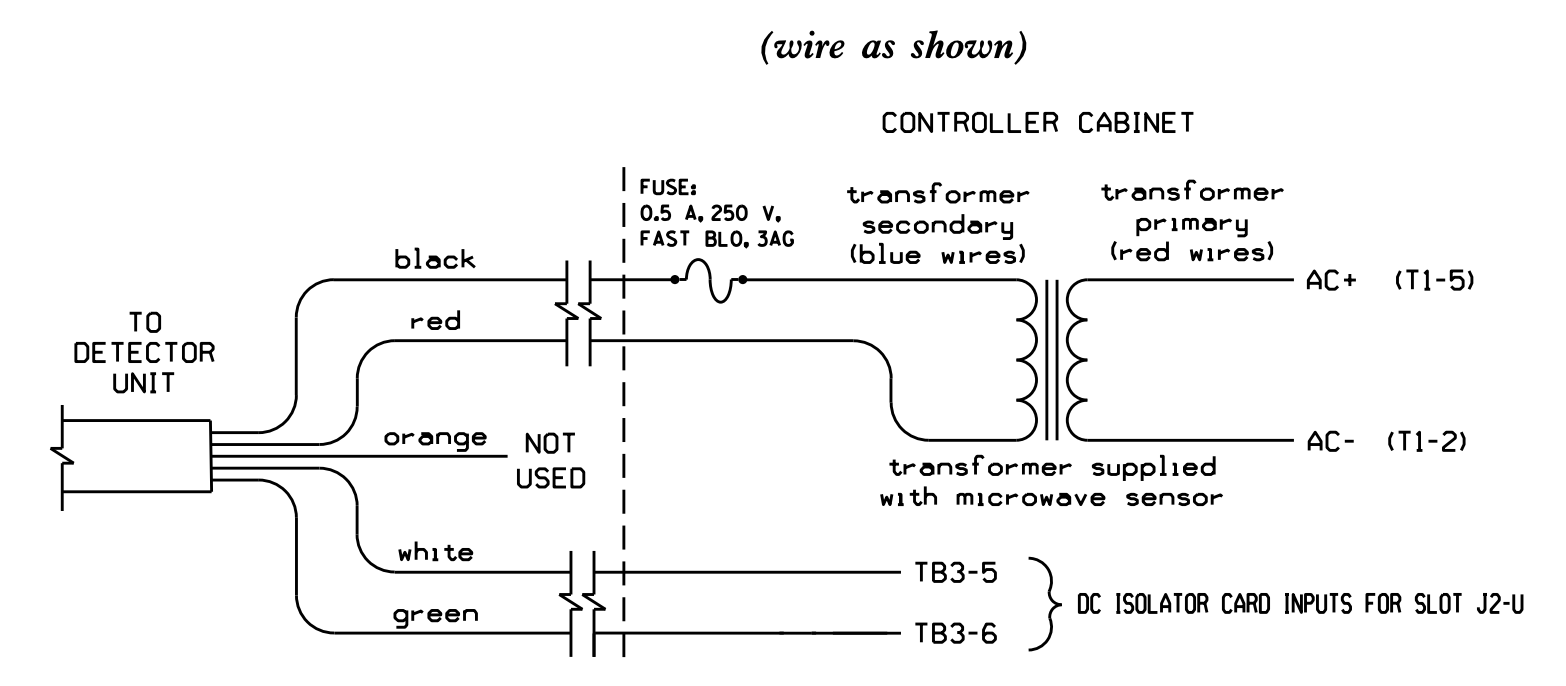

MICROWAVE DETECTOR WIRE LIST

COLOR	FUNCTION
black	12V to 24V AC/DC (no polarity)
red	12V to 24V AC/DC (no polarity)
orange	Output Relay Normally Open
white	Output Relay Normally Closed
green	Output Relay Common

- NOTES:
- Sensor is a microwave motion detector mounted on poles as indicated on the Signal Design Plans.
 - Microwave wiring shown above will cause a permanent call unless the Input Assignment Programming and Logical I/O Processor Programming details are entered as shown on this sheet. These programming details will cause a call to be placed upon opening the Normally Closed contact on the microwave detector.
 - DC Isolator's LED will be ON when no call is present and will be OFF when a call is present.
 - Important: For proper operation of the microwave detector, remove surge protection from TB3-5, TB3-6, TB3-7, and TB3-8 and insert 242 DC Isolator in slot J2.

LOGICAL I/O PROCESSOR PROGRAMMING DETAIL FOR MICROWAVE DETECTOR INPUT PROCESSING

(program controller as shown below)

- FROM MAIN MENU PRESS '2' (PHASE CONTROL), THEN '1' (PHASE CONTROL FUNCTIONS). SCROLL TO THE BOTTOM OF THE MENU AND ENABLE ACT LOGIC COMMANDS 1 AND 2.
- FROM MAIN MENU PRESS '6' (OUTPUTS), THEN '3' (LOGICAL I/O PROCESSOR).

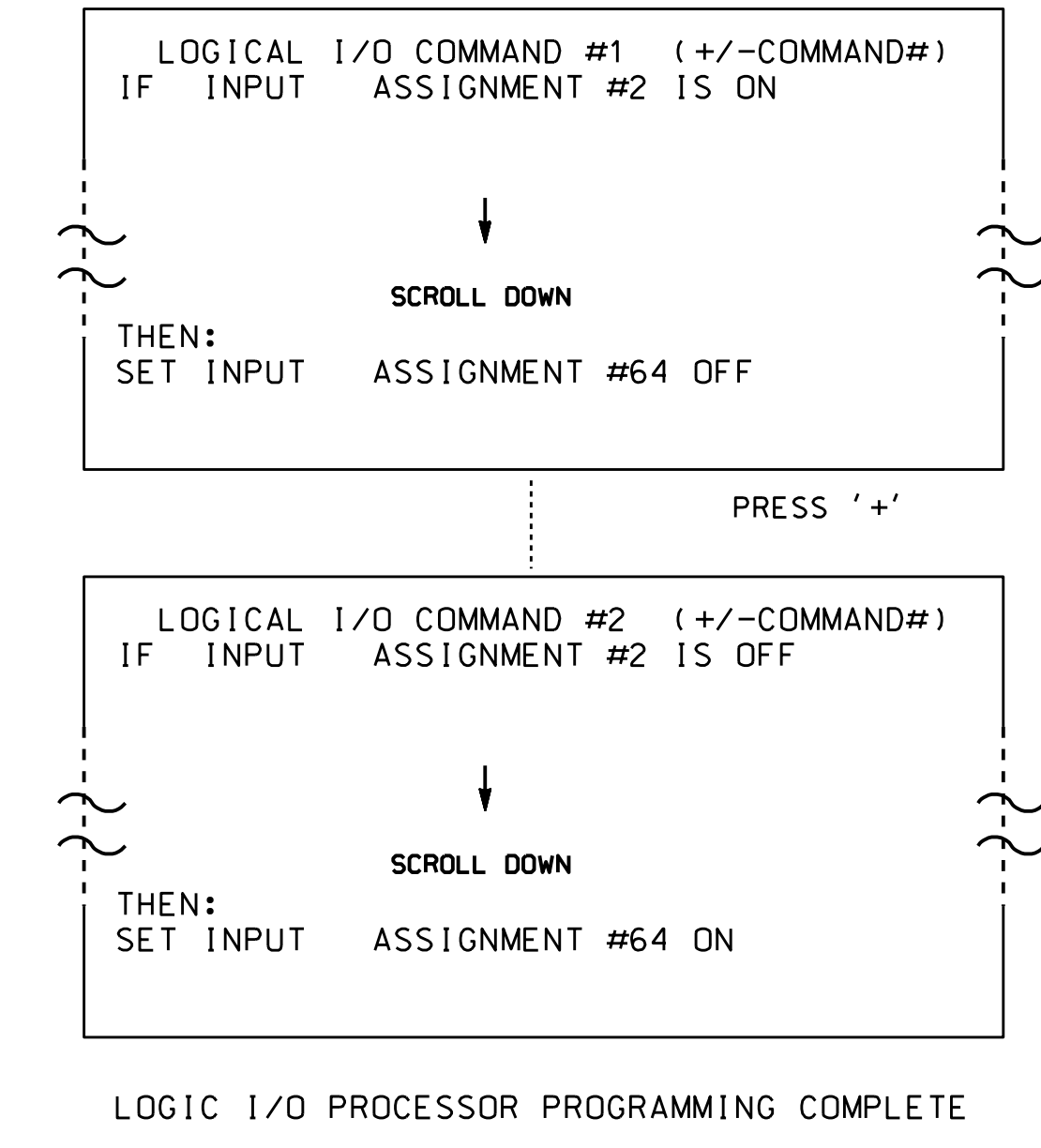

NOTE: DETECTOR CONTACTS ARE CLOSED, SO NO CALL IS 'DETECTED'.

NOTE: DETECTOR CONTACTS ARE OPEN, SO A CALL IS 'DETECTED'.

OUTPUT REFERENCE SCHEDULE

INPUT 2	= Detector Physical Input (Not Enabled)
INPUT 64	= Dummy Detector Input (Detector 6)

INPUT ASSIGNMENT PROGRAMMING DETAIL FOR MICROWAVE DETECTOR INPUT

(program controller as shown below)

FROM MAIN MENU PRESS '5' (INPUTS), THEN '+' UNTIL INPUT 2 (PIN 40) IS REACHED. MODIFY DEFAULT CONDITIONS AS INDICATED BY ARROWS.

```

PAGE: 1 C1 PIN:40 NOT ENABLED
INPUT ASSIGNMENT #.....2
DEBOUNCE TIME (0-25.5 SEC).....0.5
DELAY TIME (0-25.5 SEC).....0.0
HOLD-OVER TIME (0-25.5 SEC).....0.0
ASSIGNMENT SELECTION:
NOT ENABLED (Y/N).....Y
VEHICLE DETECTOR (1-64).....
PEDESTRIAN DETECTOR (1-16).....
ALTERNATE PED DETECTOR (1-16).....
PREEMPT (1-10).....
INVERTED PREEMPT (1-10).....
STOP TIME (Y/N).....
FLASH SENSE (Y/N).....
DOOR OPEN (Y/N).....
MANUAL CONTROL ENABLE (Y/N).....
MANUAL CONTROL ADVANCE (Y/N).....
SPECIAL FUNCTION ALARM (1-8).....
TOD HOUR SYNCHRONIZATION (0-23).....
FORCE OFF RING (1-4).....
HOLD PHASES (1-16).....
PLAN (65=FLSH,66=FREE).. OFFSET#..
CHANGE PHASE SEQUENCE PAGE (1-12)...
CHANGE PHASE TIMING PAGE (1-4).....
CHANGE PHASE CONTROL PAGE (1-4)....
CHANGE OVERLAP CONTROL PAGE (1-4)...
CHANGE INPUT PAGE (1-4).....
CHANGE OUTPUT PAGE (1-4).....
OVERRIDE PHASE CONTROL FUNCTION (Y)..
    
```

ENTER 'YES' for Not Enabled

```

PAGE: 1 C1 PIN:0 VEHICLE DETECTOR
INPUT ASSIGNMENT #.....64
DEBOUNCE TIME (0-25.5 SEC).....0.5
DELAY TIME (0-25.5 SEC).....0.0
HOLD-OVER TIME (0-25.5 SEC).....0.0
ASSIGNMENT SELECTION:
NOT ENABLED (Y/N).....
VEHICLE DETECTOR (1-64).....6
PEDESTRIAN DETECTOR (1-16).....
ALTERNATE PED DETECTOR (1-16).....
PREEMPT (1-10).....
INVERTED PREEMPT (1-10).....
STOP TIME (Y/N).....
FLASH SENSE (Y/N).....
DOOR OPEN (Y/N).....
MANUAL CONTROL ENABLE (Y/N).....
MANUAL CONTROL ADVANCE (Y/N).....
SPECIAL FUNCTION ALARM (1-8).....
TOD HOUR SYNCHRONIZATION (0-23).....
FORCE OFF RING (1-4).....
HOLD PHASES (1-16).....
PLAN (65=FLSH,66=FREE)..65 OFFSET#..
CHANGE PHASE SEQUENCE PAGE (1-12)...
CHANGE PHASE TIMING PAGE (1-4).....
CHANGE PHASE CONTROL PAGE (1-4)....
CHANGE OVERLAP CONTROL PAGE (1-4)...
CHANGE INPUT PAGE (1-4).....
CHANGE OUTPUT PAGE (1-4).....
OVERRIDE PHASE CONTROL FUNCTION (Y)..
    
```

ENTER '6' for Vehicle Detector

PRESS '-' until Input Assignment #64 is reached

PROGRAMMING COMPLETE

NOTE: This remapping removes the default detector from the microwave's physical input and reassigns it to unused INPUT 64. The Logical I/O Processor Programming Detail on this sheet will invert the disabled input and control INPUT 64 and the reassigned detector.

THIS ELECTRICAL DETAIL IS FOR THE SIGNAL DESIGN: 07-1593
 DESIGNED: March 2014
 SEALED: 4/1/2015
 REVISED: N/A

Electrical Detail - Sheet 2 of 2

	SR 1486 (Greensboro Road) at I-74 EB/US 311 SB Ramps	SEAL JOHN T. ROWE, JR. ENGINEER 008453
Prepared In the Offices of: 750 N. Greenfield Pkwy, Garner, NC 27529	Division 7 Guilford County High Point PLAN DATE: May 2014 REVIEWED BY: [Signature] PREPARED BY: S. Armstrong REVIEWED BY: [Signature]	DocuSigned by: John T. Rowe, Jr. 4/8/2015 SIG. INVENTORY NO. 07-1593

06-APR-2015 14:31 S:\IT\SS\115_Signal\work\hgr\cdus\sig_Microwave\stron071593_sml.ele.xxx.dgn sarminstron