

**EDI MODEL 2018EClip-NC CONFLICT MONITOR PROGRAMMING DETAIL**  
(remove jumpers and set switches as shown)

REMOVE DIODE JUMPERS 2-6, 2-9, 2-11, 2-13, 2-15, 4-7, 4-8, 4-10, 4-12, 4-14, 4-16, 6-9, 6-11, 6-13, 6-15, 7-10, 7-12, 7-14, 8-10, 8-12, 8-14, 8-16, 9-11, 9-13, 9-15, 10-12, 10-14, 10-16, 11-13, 11-15, 12-14, 12-16, 13-15 and 14-16.

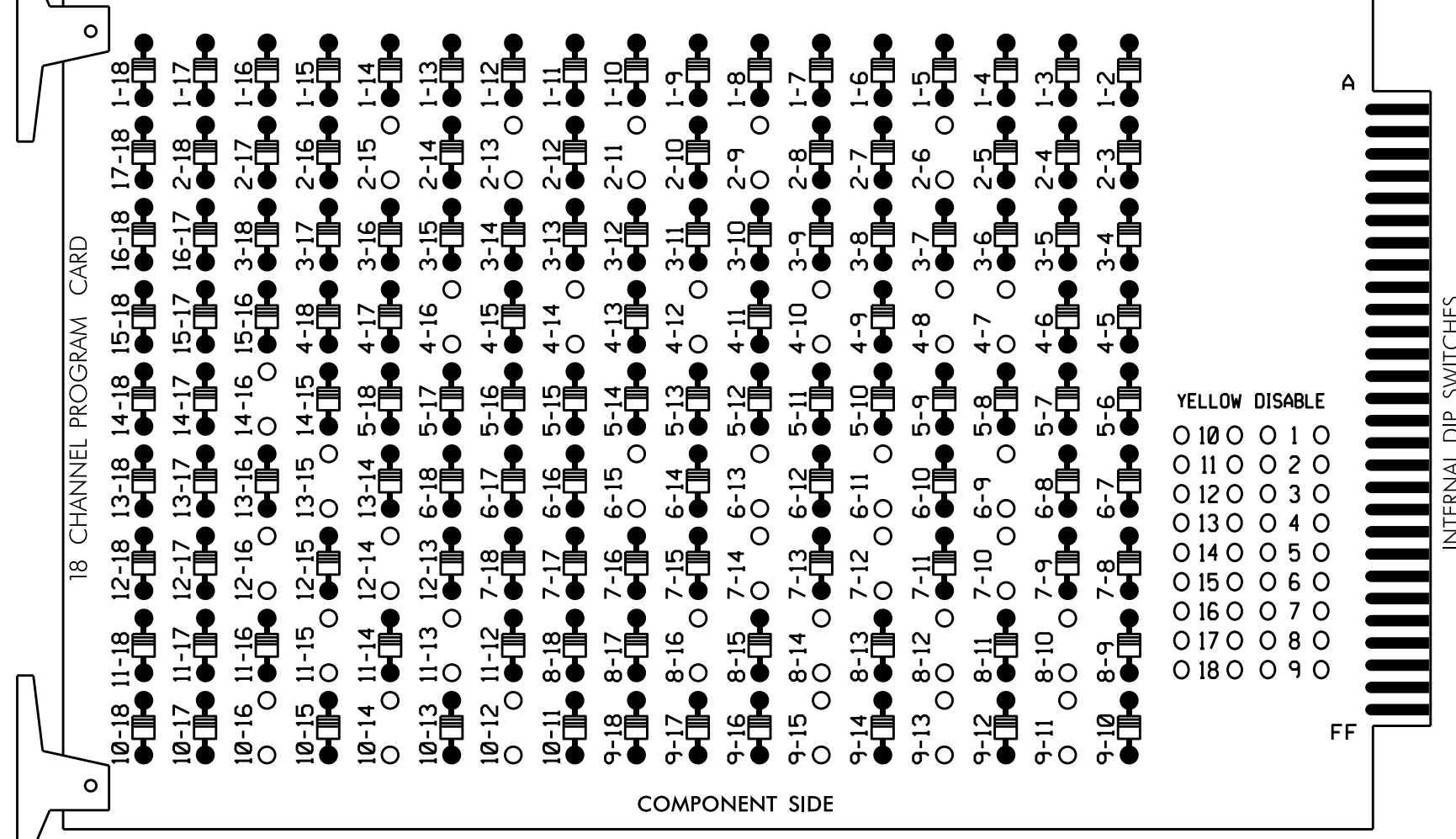

REMOVE JUMPERS AS SHOWN

**NOTES:**

- Card is provided with all diode jumpers in place. Removal of any jumper allows its channels to run concurrently.
- Ensure jumpers SEL2-SEL5 and SEL9 are present on the monitor board.
- Ensure that Red Enable is active at all times during normal operation.
- Integrate monitor with Ethernet network in cabinet.

■ = DENOTES POSITION OF SWITCH

**NOTES**

- To prevent "flash-conflict" problems, insert red flash program blocks for all unused vehicle load switches in the output file. The installer shall verify that signal heads flash in accordance with the Signal Plans.
- Program phases 4 and 8 for Dual Entry.
- Enable Simultaneous Gap-Out for all phases.
- Program phases 2 and 6 for Start Up In Green.
- Program phases 2, 4, 6 and 8 for 'STARTUP PED CALL'.
- Program phases 2 and 6 for Yellow Flash and overlaps 1 and 2 as Wag Overlaps.
- The cabinet and controller are part of the High Pint Signal System.

**EQUIPMENT INFORMATION**

CONTROLLER.....2070L  
 CABINET.....332 /W/ AUX  
 SOFTWARE.....ECONOLITE OASIS  
 CABINET MOUNT.....BASE  
 OUTPUT FILE POSITIONS...18 WITH AUX. OUTPUT FILE  
 LOAD SWITCHES USED.....S2,S3,S5,S6,S8,S9,S10,S11,S12,  
 AUX S1,AUX S2,AUX S4,AUX S5.  
 PHASES USED.....2,4,6,7,8,2 PED,4 PED,6 PED,8 PED.  
 OVERLAP "A".....2  
 OVERLAP "B".....4  
 OVERLAP "C".....6  
 OVERLAP "D".....7+8

**SIGNAL HEAD HOOK-UP CHART**

| LOAD SWITCH NO.       | S1 | S2    | S3       | S4  | S5    | S6       | S7 | S8    | S9       | S10 | S11   | S12      | AUX S1 | AUX S2 | AUX S3 | AUX S4 | AUX S5 | AUX S6 |
|-----------------------|----|-------|----------|-----|-------|----------|----|-------|----------|-----|-------|----------|--------|--------|--------|--------|--------|--------|
| CMU CHANNEL NO.       | 1  | 2     | 13       | 3   | 4     | 14       | 5  | 6     | 15       | 7   | 8     | 16       | 9      | 10     | 17     | 11     | 12     | 18     |
| PHASE                 | 1  | 2     | 2 PED    | 3   | 4     | 4 PED    | 5  | 6     | 6 PED    | 7   | 8     | 8 PED    | OLA    | OLB    | SPARE  | OLC    | OLD    | SPARE  |
| SIGNAL HEAD NO.       | NU | 22,23 | P21, P22 | NU  | 41,42 | P41, P42 | NU | 62,63 | P61, P62 | 71* | 82,83 | P81, P82 | 61*    | 81*    | NU     | 21*    | 71*    | NU     |
| RED                   |    | 128   |          |     | 101   |          |    | 134   |          |     | 107   |          |        |        |        |        |        |        |
| YELLOW                |    | 129   |          |     | 102   |          |    | 135   |          | *   | 108   |          |        |        |        |        |        |        |
| GREEN                 |    | 130   |          |     | 103   |          |    | 136   |          |     | 109   |          |        |        |        |        |        |        |
| RED ARROW             |    |       |          |     |       |          |    |       |          |     |       |          | A121   | A124   |        | A114   | A101   |        |
| YELLOW ARROW          |    |       |          |     |       |          |    |       |          |     |       |          | A122   | A125   |        | A115   | A102   |        |
| FLASHING YELLOW ARROW |    |       |          |     |       |          |    |       |          |     |       |          | A123   | A126   |        | A116   | A103   |        |
| GREEN ARROW           |    |       |          |     |       |          |    |       |          | 124 |       |          |        |        |        |        |        |        |
| Hand icon             |    |       |          | 113 |       | 104      |    | 119   |          |     |       | 110      |        |        |        |        |        |        |
| Walking person icon   |    |       |          | 115 |       | 106      |    | 121   |          |     |       | 112      |        |        |        |        |        |        |

NU = Not Used  
 \* Denotes install load resistor. See load resistor installation detail this sheet.  
 \* See pictorial of head wiring in detail below.

**INPUT FILE POSITION LAYOUT**  
(from view)

| FILE "I" | 1  | 2        | 3        | 4  | 5        | 6        | 7        | 8        | 9        | 10       | 11       | 12          | 13          | 14          |
|----------|----|----------|----------|----|----------|----------|----------|----------|----------|----------|----------|-------------|-------------|-------------|
| U        | ∅2 | ∅2       | ∅2       | ∅4 | S        | S        | S        | S        | S        | S        | S        | ∅2 PED      | ∅6 PED      | FS          |
| L        | 2A | 2C       | NOT USED | 4A | NOT USED | NOT USED | NOT USED | NOT USED | NOT USED | NOT USED | NOT USED | DC ISOLATOR | DC ISOLATOR | DC ISOLATOR |
| U        | ∅6 | ∅6       | ∅7       | ∅8 | S        | S        | S        | S        | S        | S        | S        | S           | S           | S           |
| L        | 6A | 6C       | 7A       | 8A | NOT USED | NOT USED | NOT USED | NOT USED | NOT USED | NOT USED | NOT USED | NOT USED    | NOT USED    | NOT USED    |
| U        | ∅6 | NOT USED | ∅8       | ∅8 | S        | S        | S        | S        | S        | S        | S        | S           | S           | S           |
| L        | 6B | NOT USED | 8B       | 8B | NOT USED | NOT USED | NOT USED | NOT USED | NOT USED | NOT USED | NOT USED | NOT USED    | NOT USED    | NOT USED    |

EX.: 1A, 2A, ETC. = LOOP NO.'S

FS = FLASH SENSE  
 ST = STOP TIME

⊗ Wired Input - Do not populate slot with detector card

**INPUT FILE CONNECTION & PROGRAMMING CHART**

| LOOP NO.         | LOOP TERMINAL | INPUT FILE POS. | PIN NO. | INPUT ASSIGNMENT NO. | DETECTOR NO. | NEMA PHASE | CALL  | EXTEND | FULL TIME DELAY | STRETCH TIME | DELAY TIME |
|------------------|---------------|-----------------|---------|----------------------|--------------|------------|-------|--------|-----------------|--------------|------------|
| 2A               | TB2-5,6       | I2U             | 39      | 1                    | 2            | 2          | Y     | Y      |                 |              |            |
| 2B               | TB2-7,8       | I2L             | 43      | 5                    | 12           | 2          | Y     | Y      |                 |              |            |
| 2C               | TB2-9,10      | I3U             | 63      | 25                   | 32           | 2          | Y     | Y      |                 |              |            |
| 4A               | TB4-9,10      | I6U             | 41      | 3                    | 4            | 4          | Y     | Y      |                 |              | 10         |
| * S1             | TB6-9,10      | I9U             | 60      | 22                   | 11           | SYS        |       |        |                 |              |            |
| * S2             | TB6-11,12     | I9L             | 62      | 24                   | 13           | SYS        |       |        |                 |              |            |
| 6A               | TB3-5,6       | J2U             | 40      | 2                    | 6            | 6          | Y     | Y      |                 |              |            |
| 6B               | TB3-7,8       | J2L             | 44      | 6                    | 16           | 6          | Y     | Y      |                 |              |            |
| 6C               | TB3-9,10      | J3U             | 64      | 26                   | 36           | 6          | Y     | Y      |                 |              |            |
| 7A <sup>1</sup>  | TB5-5,6       | J5U             | 57      | 19                   | 7            | 7          | Y     | Y      |                 |              | 15         |
|                  | -             | I8U             | 49      | 11                   | 24           | 4          | Y     | Y      |                 |              |            |
| 8A               | TB5-9,10      | J6U             | 42      | 4                    | 8            | 8          | Y     | Y      |                 |              | 3          |
| 8B               | TB5-11,12     | J6L             | 46      | 8                    | 18           | 8          | Y     | Y      |                 |              | 10         |
| PED PUSH BUTTONS |               |                 |         |                      |              |            |       |        |                 |              |            |
| P21,P22          | TB8-4,6       | I12U            | 67      | 29                   |              |            | PED 2 | 2 PED  |                 |              |            |
| P41,P42          | TB8-5,6       | I12L            | 69      | 31                   |              |            | PED 4 | 4 PED  |                 |              |            |
| P61,P62          | TB8-7,9       | I13U            | 68      | 30                   |              |            | PED 6 | 6 PED  |                 |              |            |
| P81,P82          | TB8-8,9       | I13L            | 70      | 32                   |              |            | PED 8 | 8 PED  |                 |              |            |

NOTE:  
 INSTALL DC ISOLATORS IN INPUT FILE SLOTS 112 AND 113.

<sup>1</sup>Add jumper from J5-W to I8-W, on rear of input file.

\* System detector only. Remove the vehicle phase assigned to this detector in the default programming.

INPUT FILE POSITION LEGEND: J2L

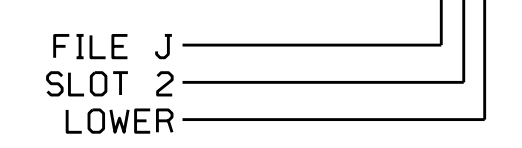

**COUNTDOWN PEDESTRIAN SIGNAL OPERATION**

Countdown Ped Signals are required to display timing only during Ped Clearance Interval. Consult Ped Signal Module user's manual for instructions on selecting this feature.

**4 SECTION FYA PPLT SIGNAL WIRING DETAIL**  
(wire signal heads as shown)

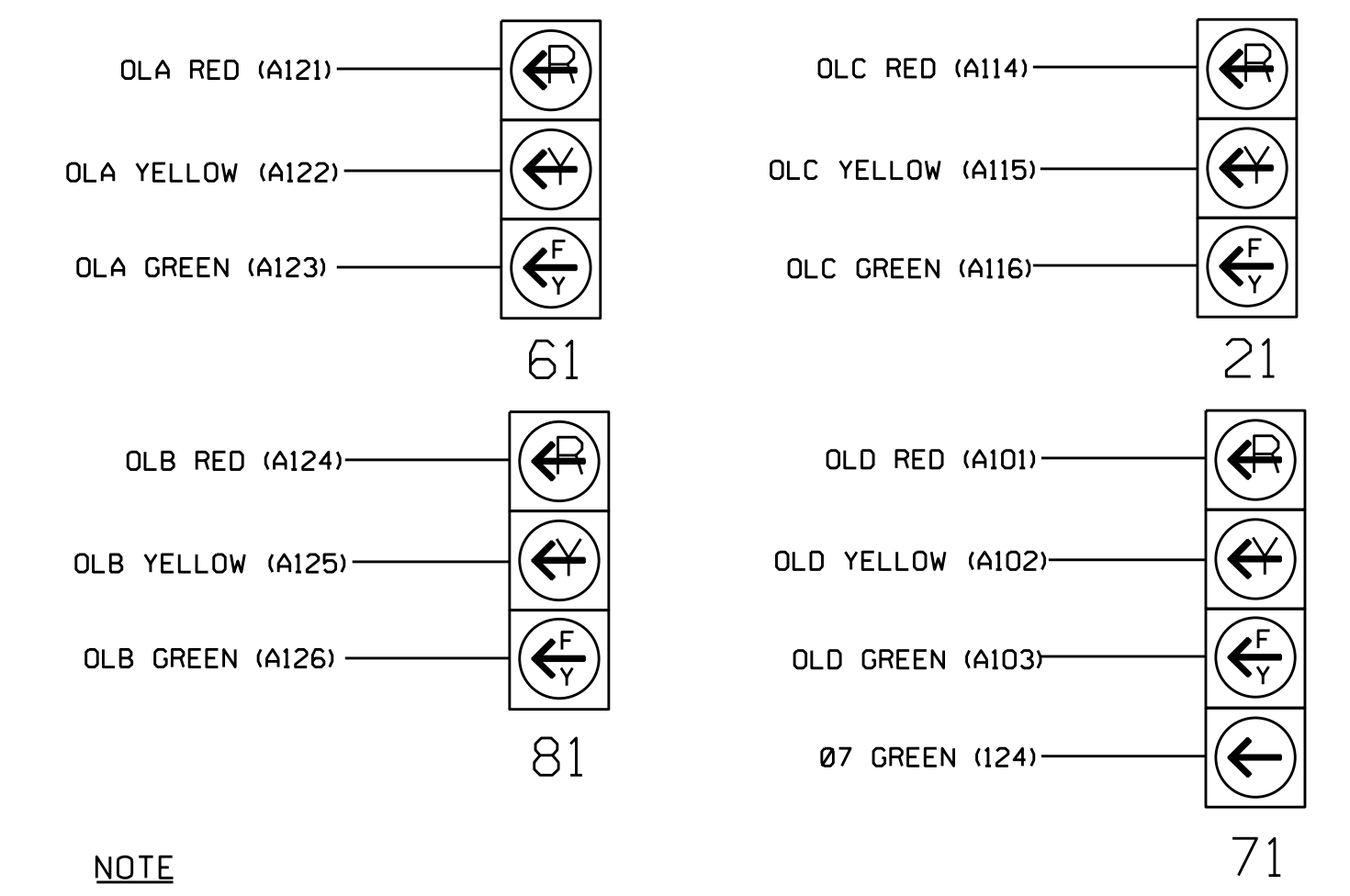

**NOTE**

1. The sequence display for these signals require special logic programming. See sheet 2 for programming instructions.

**LOAD RESISTOR INSTALLATION DETAIL**  
(install resistors as shown below)

| VALUE (ohms) | WATTAGE   |
|--------------|-----------|
| 1.5K - 1.9K  | 25W (min) |
| 2.0K - 3.0K  | 10W (min) |

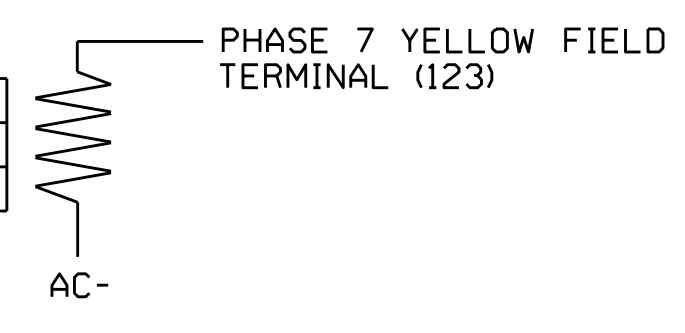

THIS ELECTRICAL DETAIL IS FOR THE SIGNAL DESIGN: 07-0762  
 DESIGNED: September 2014  
 SEALED: 4-24-15  
 REVISED: N/A

ELECTRICAL DETAIL SHEET 1 OF 2

Prepared In the Offices of:  
 TRANSPORTATION MOBILITY AND SAFETY CONSULTANTS, INC.  
 750 N. Greenfield Pkwy, Garner, NC 27529

SR 1009 (North Main Street) at Parkway Avenue

Division 7 Guilford County High Point

PLAN DATE: October 2014 REVIEWED BY: JTR

PREPARED BY: James Peterson REVIEWED BY:

REVISIONS INIT. DATE

Seal: JOHN T. ROWE, JR., PROFESSIONAL ENGINEER, No. 008453

DocuSigned by: John T. Rowe, Jr. 5/5/2015

SIG. INVENTORY NO. 07-0762