

GEOTECHNICAL ENGINEER

ENGINEER

SEAL 032672

Michael V. Vignette 7/15/2015

SIGNATURE DATE SIGNATURE DATE

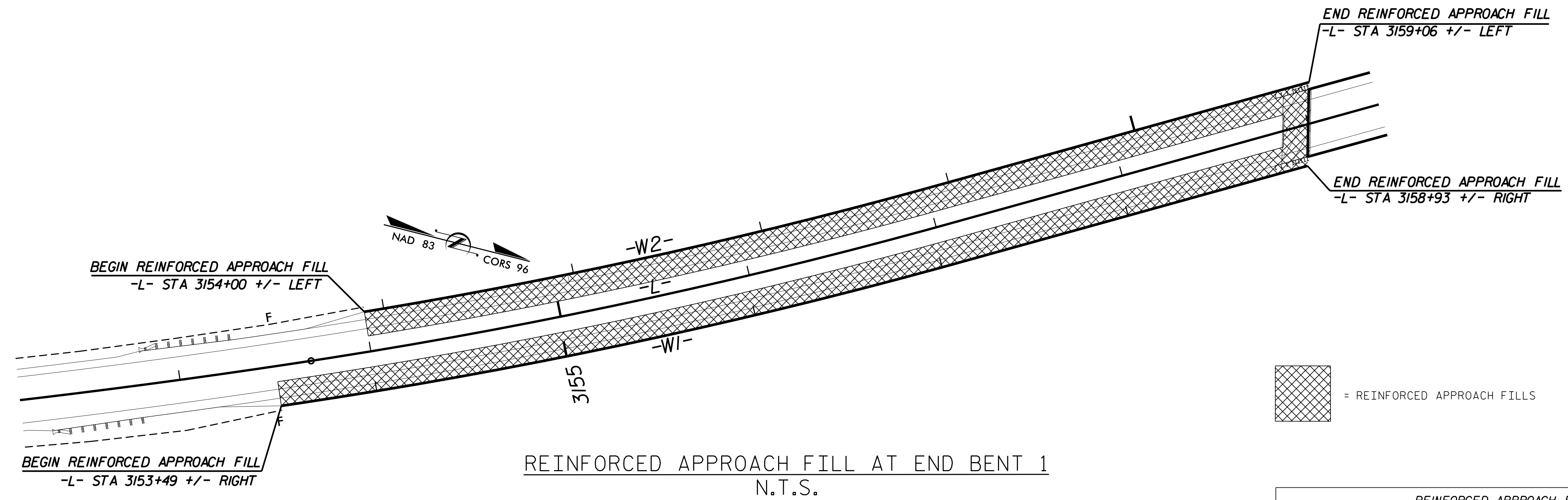

= REINFORCED APPROACH FILLS

**REINFORCED APPROACH FILLS ESTIMATED QUANTITIES**

"REINFORCED APPROACH FILLS" AT EB1.....8,335 SQ.FT.  
 "REINFORCED APPROACH FILLS" AT EB2.....5,590 SQ.FT.  
 TOTAL "REINFORCED APPROACH FILLS".....13,925 SQ.FT.

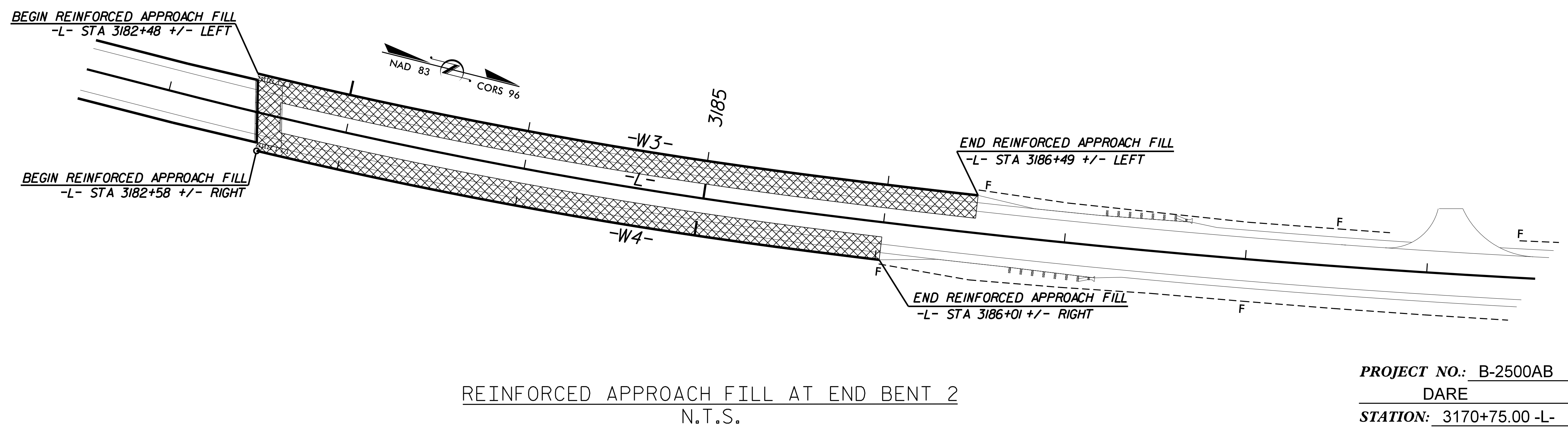

**PROJECT NO.:** B-2500AB  
**DARE COUNTY**  
**STATION:** 3170+75.00 -L-  
 SHEET 1 OF 2

PREPARED BY: MDV DATE: 7/15  
 REVIEWED BY: CAK DATE: 7/15

**GEOTECHNICAL ENGINEERING UNIT**

EASTERN REGIONAL OFFICE  
 WESTERN REGIONAL OFFICE  
 CONTRACT OFFICE

STATE OF NORTH CAROLINA  
 DEPARTMENT OF TRANSPORTATION  
 RALEIGH

**REINFORCED APPROACH FILLS**

REVISIONS						SHEET NO.
NO.	BY	DATE	NO.	BY	DATE	W-12
1			3			TOTAL SHEETS
2			4			13