

NOTES

FOR GENERAL NOTES AND NOTES REGARDING MATERIALS AND CORROSION PROTECTION, SEE GENERAL DRAWINGS.  
 FOR CONCRETE SHEET PILE DESIGN PARAMETERS, SEE SHEET 6 OF 11.  
 FOR CONCRETE SHEET PILE FOUNDATION NOTES, SEE SHEET 6 OF 11.  
 TOP OF PILE ELEVATIONS SHOWN ARE THE MAXIMUM ALLOWABLE TOP OF SECTION 452 OF THE STANDARD SPECIFICATIONS.  
 FOR CONCRETE SHEET PILE WALL, SEE SPECIAL PROVISIONS.  
 FOR GROUT FOR STRUCTURES, SEE SPECIAL PROVISIONS.

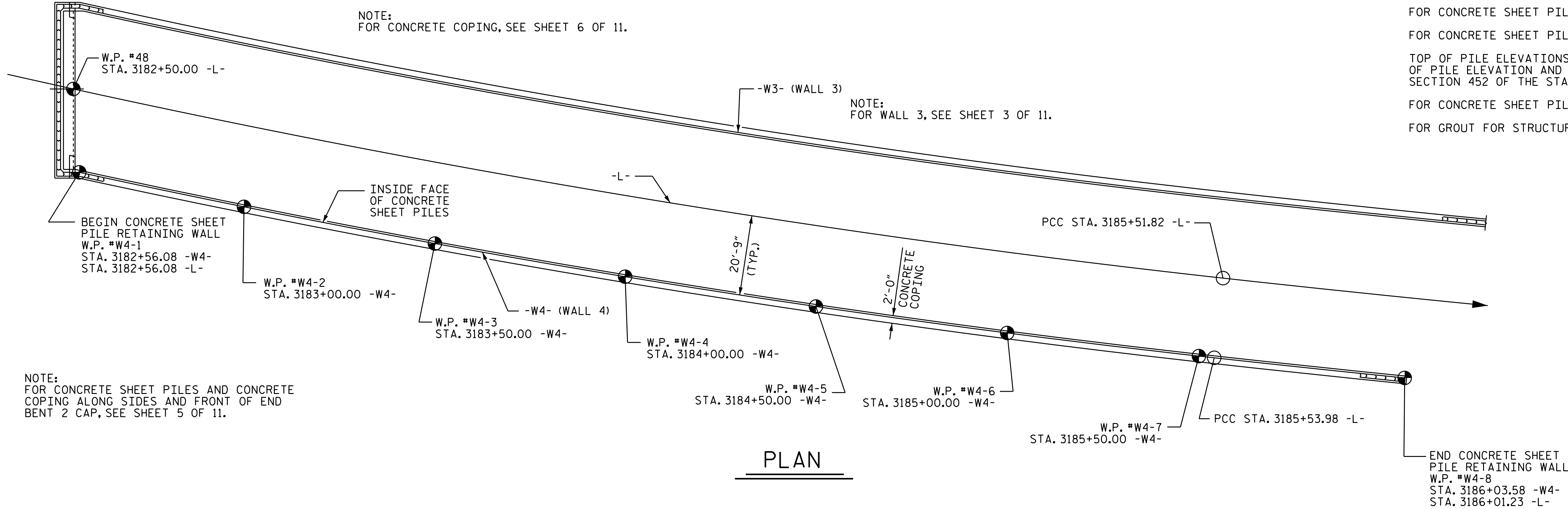

PLAN

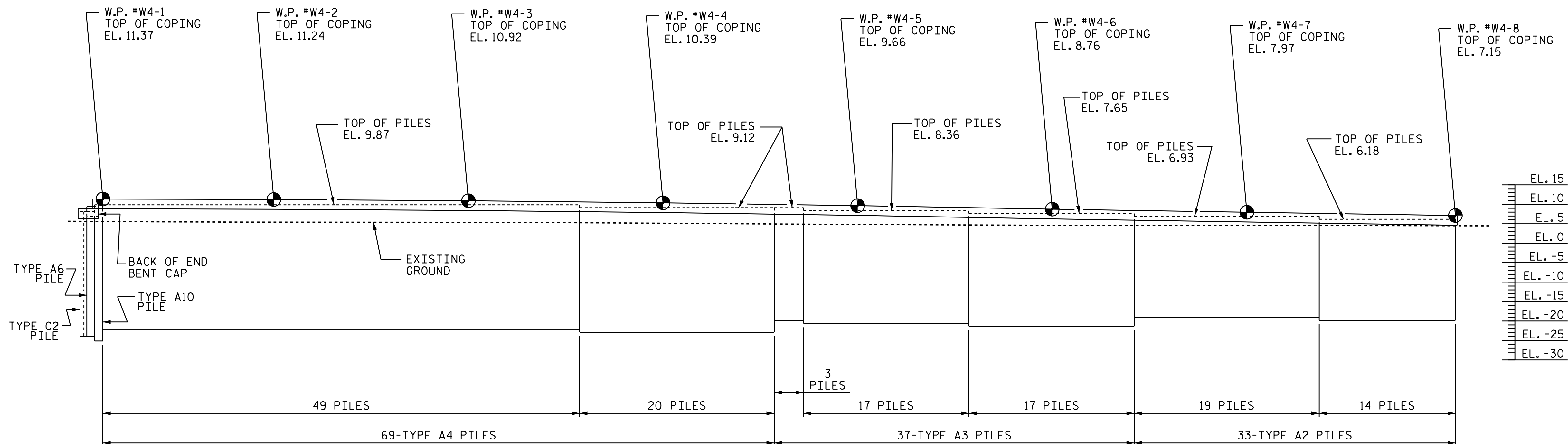

WALL 4 ELEVATION

NOTE: INDIVIDUAL PILES WITHIN PILE GROUPS NOT SHOWN FOR CLARITY

NOTE: CAST-IN-PLACE CONCRETE COPING SHALL EXTEND 6" BEYOND LAST PILE AT W.P. #W4-8.



PROJECT NO. B-2500AB  
DARE COUNTY  
 STATION: 3170+75.00 -L-

SHEET 4 OF 11

STATE OF NORTH CAROLINA  
 DEPARTMENT OF TRANSPORTATION  
 RALEIGH

CONCRETE SHEET PILE  
 RETAINING WALL  
 WALL 4

REVISIONS						SHEET NO.
NO.	BY:	DATE:	NO.	BY:	DATE:	W-4
1			3			TOTAL SHEETS
2			4			13

DRAWN BY: T. M. GARRISON, P.E. DATE: 6/15  
 CHECKED BY: M. A. ALLEN DATE: 6/15  
 DESIGN ENGINEER OF RECORD: T. M. GARRISON, P.E. DATE: 6/15