

PLAN
(FOR PILE BLOCKOUT DETAILS, SEE SHEET 5 OF 6)

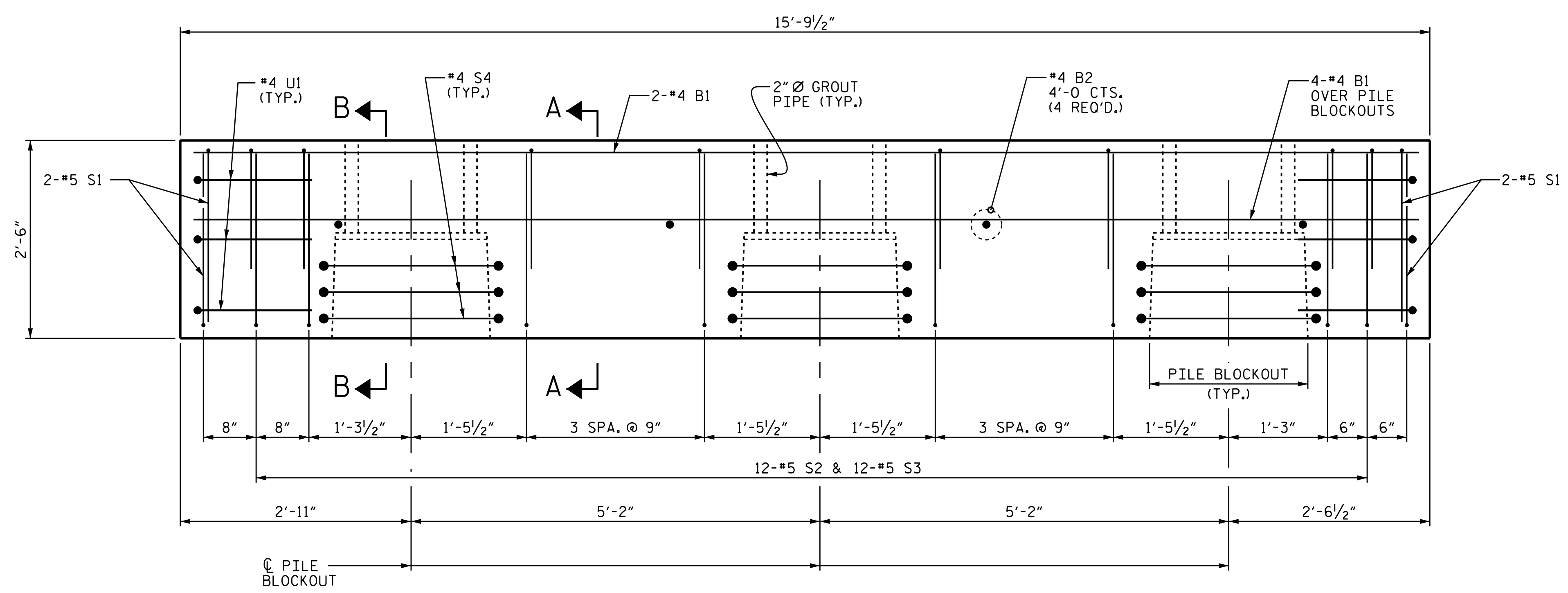

ELEVATION
(*6 D1 AND *4 D2 DOWELS NOT SHOWN FOR CLARITY)
FOR SECTION A-A AND SECTION B-B, SEE SHEET 5 OF 6.

**BILL OF MATERIAL
FOR ONE PIECE EB1-01**

BAR	NO.	SIZE	TYPE	LENGTH	WEIGHT
B1	6	#4	STR	15'-5"	62
B2	4	#4	STR	2'-8"	7
D1	9	#6	STR	1'-6"	20
*D2	4	#4	STR	2'-9"	7
S1	8	#5	1	6'-5"	54
S2	12	#5	1	7'-3"	91
S3	12	#5	1	5'-9"	72
S4	9	#4	2	9'-9"	59
U1	6	#4	1	5'-7"	22
REINFORCING STEEL					387 LBS
* EPOXY COATED REINFORCING STEEL					7 LBS
4000 PSI PRESTRESS CONCRETE					3.9 C.Y.
PILE BLOCKOUT GROUT ▲					0.4 C.Y.
0.6" Ø L.R. STRANDS					No. 12

BAR TYPES

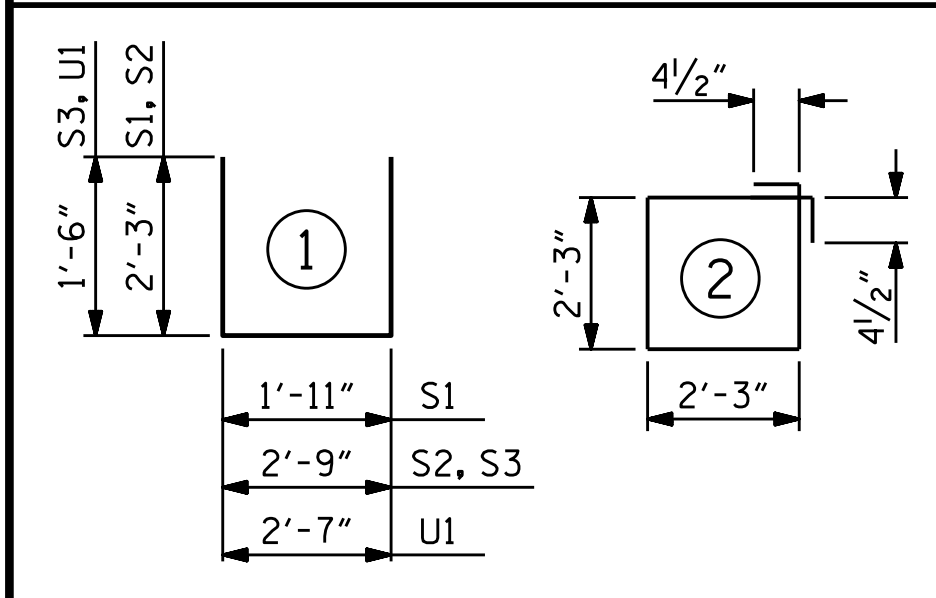

ALL BAR DIMENSIONS ARE OUT TO OUT.

▲ GROUT DISPLACED BY THE 16" PRESTRESSED CONCRETE PILES HAS BEEN DEDUCTED FROM THE GROUT QUANTITY.

GRADE 270 STRANDS

	0.6" Ø L.R.
AREA (SQUARE INCHES)	0.217
ULTIMATE STRENGTH (LBS. PER STRAND)	58,600
APPLIED PRESTRESS (LBS. PER STRAND)	43,950

PROJECT NO. B-2500AB
DARE COUNTY
 STATION: 3170+75.00 -L-

SHEET 2 OF 6



STATE OF NORTH CAROLINA
 DEPARTMENT OF TRANSPORTATION
 RALEIGH

SUBSTRUCTURE

**PRESTRESSED
PIECE EB1-01**

REVISIONS						SHEET NO.
NO.	BY:	DATE:	NO.	BY:	DATE:	TOTAL SHEETS
1			3			44
2			4			

ASSEMBLED BY : M.A. ALLEN	DATE : 6/15
CHECKED BY : T.M. GARRISON	DATE : 6/15
DRAWN BY : MAA 7/12	
CHECKED BY : SHS 8/12	

DocuSigned by:
 Todd M. Garrison
 8/3/2015