

**This electronic collection of documents is provided  
for the convenience of the user  
and is Not a Certified Document –**

**The documents contained herein were originally issued  
and sealed by the individuals whose names and license  
numbers appear on each page, on the dates appearing  
with their signature on that page.**

**This file or an individual page  
shall not be considered a certified document.**

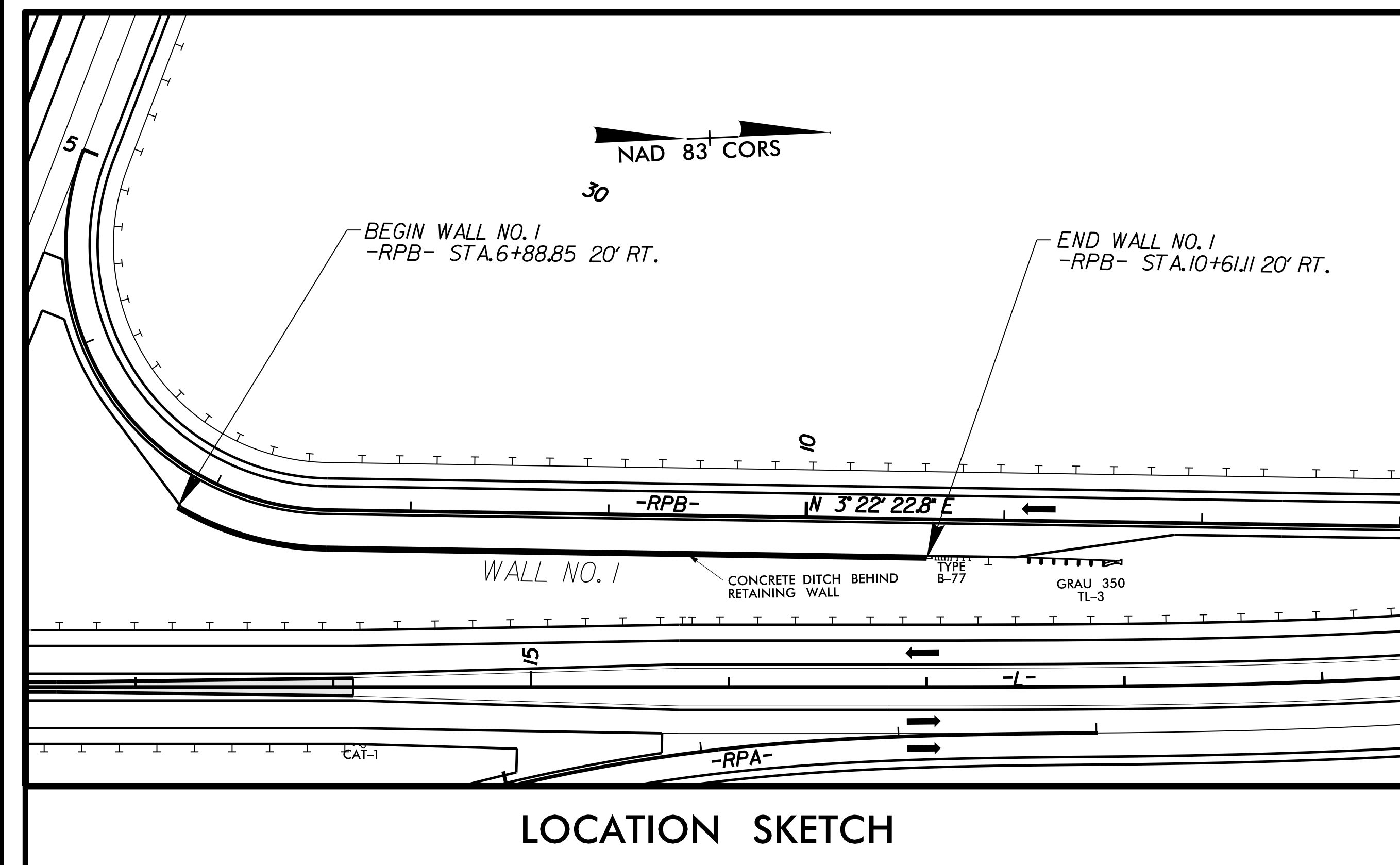

ESTIMATED MSE WALL QUANTITY (SQUARE FEET)	
MSE RETAINING WALL NO. 1	4,000 +/- SF

GEOTECHNICAL ENGINEER

ENGINEER

SEAL 29869

STATE OF NORTH CAROLINA PROFESSIONAL ENGINEERS EXAMINING BOARD

7/31/2015

SIGNATURE DATE SIGNATURE DATE

RETAINING WALL ELEVATIONS						
-RPB- STA	-WALL- STA	OFFSET FROM C (RIGHT)	ELEV @ TOP OF WALL	* PROPOSED FINISHED GRADE	* EXPOSED / DESIGN WALL HEIGHT	** WALL HEIGHT "H"
6+88.85	10+00.00	20.0	2,999.48	2,999.48	0.00	2.00
7+21.35	10+32.50	20.0	3,009.08	2,999.94	9.14	11.14
7+61.08	10+82.50	20.0	3,012.26	3,000.65	11.61	13.61
8+11.08	11+32.50	20.0	3,012.24	3,001.67	10.57	12.57
8+61.08	11+82.50	20.0	3,012.14	3,002.93	9.21	11.21
9+11.08	12+32.50	20.0	3,011.87	3,004.05	7.82	9.82
9+61.08	12+82.50	20.0	3,011.25	3,004.91	6.34	8.34
10+11.08	13+32.50	20.0	3,010.25	3,005.49	4.76	6.76
10+61.11	13+82.50	20.0	3,008.83	3,005.83	3.00	5.00

\* ELEVATION @ PROPOSED FINISHED GRADE AND EXPOSED WALL HEIGHT DO NOT INCLUDE EMBEDMENT DEPTH

\*\* FOR DESIGN WALL HEIGHT "H" AND ADDITIONAL CONSTRUCTION DETAILS, SEE SHEETS 2 AND 3 OF 3.

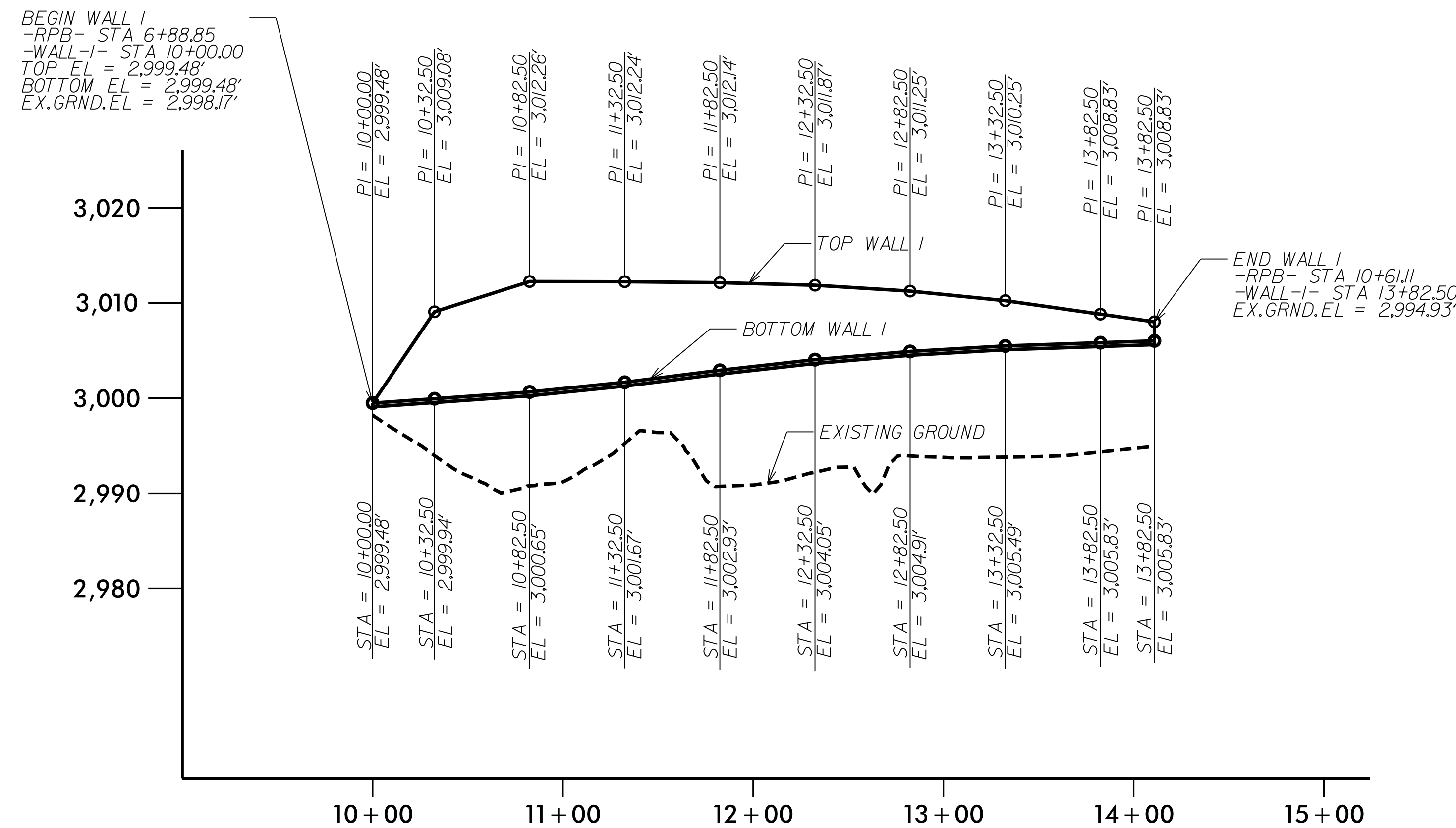

WALL ENEVELOPE

PROJECT NO.: R-2915 A

WATAUGA / ASHE COUNTY

STATION: -RPB- 6+88.85 TO -RPB- 10+61.11

SHEET 1 OF 3

PREPARED BY: MHS DATE: 7/28/15

REVIEWED BY: SCC DATE: 7/28/15

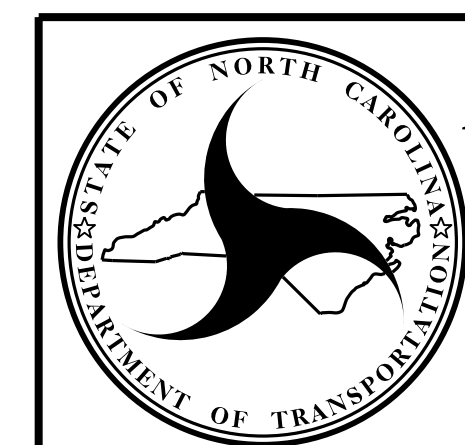

NORTH CAROLINA  
DEPARTMENT OF TRANSPORTATION  
DIVISION OF HIGHWAYS

GEOTECHNICAL  
ENGINEERING UNIT

MECHANICALLY STABILIZED  
EARTH (MSE) RETAINING  
WALL NO. 1

REVISIONS						SHEET NO.
NO.	BY	DATE	NO.	BY	DATE	
1			3			W-1
2			4			

GEOTECHNICAL ENGINEER   SIGNATURE DATE	ENGINEER   SIGNATURE DATE
--	------------------------------------

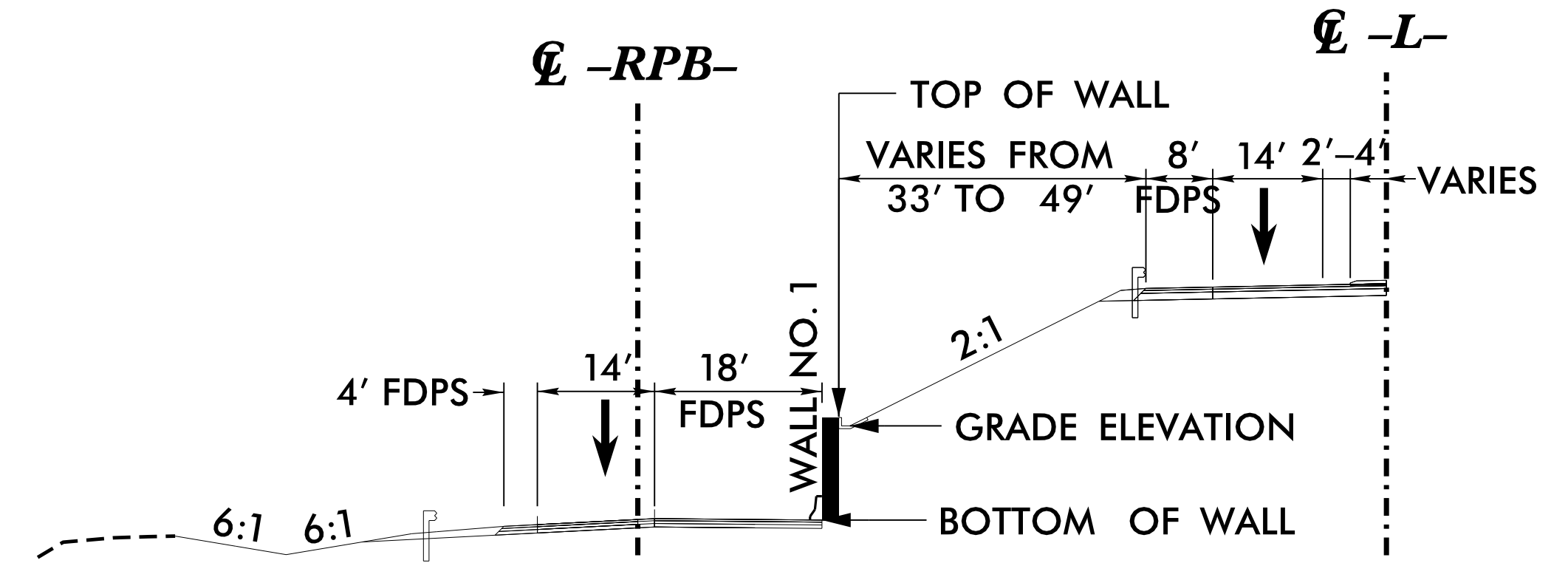
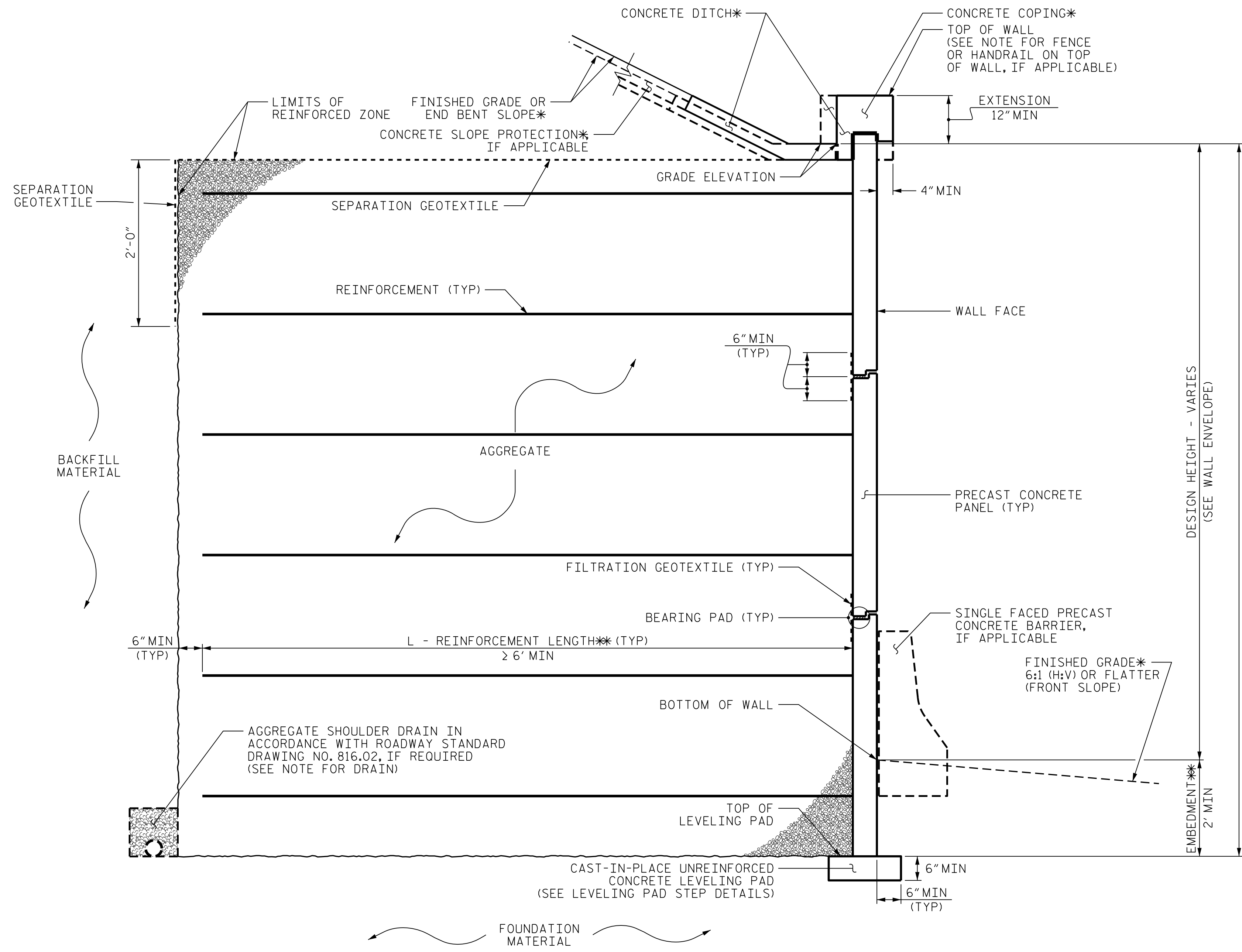

**TYPICAL DETAIL**  
 RETAINING WALL NO. 1  
 -L- STA. 13+39.38 LT. TO STA. 17+00.00 LT.  
 N.T.S.

**MSE WALL WITH PRECAST PANELS - TYPICAL SECTION**

\*SEE COPING DETAILS AND PLANS FOR FINISHED GRADE OR END BENT SLOPE DETAILS.  
 \*\*SEE MSE RETAINING WALLS PROVISION FOR EMBEDMENT AND REINFORCEMENT LENGTH REQUIREMENTS.

PROJECT NO.:           R-2915 A            
          WATAUGA / ASHE           COUNTY  
 STATION: -RPB- 6+88.85 TO -RPB- 10+61.11  
 SHEET 2 OF 3

PREPARED BY: MHS                      DATE: 7 / 28 / 15  
 REVIEWED BY: SCC                      DATE: 7 / 28 / 15

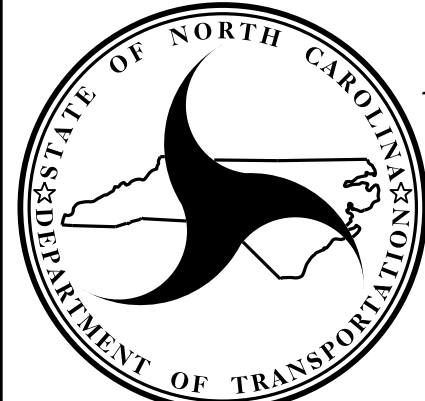

**NORTH CAROLINA**  
**DEPARTMENT OF TRANSPORTATION**  
**DIVISION OF HIGHWAYS**  
  
**GEOTECHNICAL**  
**ENGINEERING UNIT**

MECHANICALLY STABILIZED EARTH (MSE) RETAINING WALL NO. 1					
REVISIONS					
NO.	BY	DATE	NO.	BY	DATE
1			3		
2			4		

SHEET NO. W-2

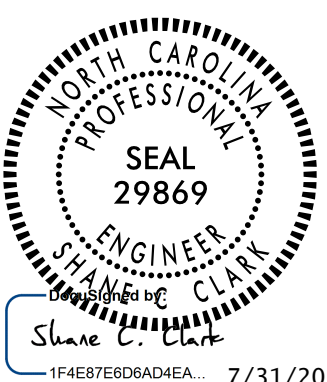
GEOTECHNICAL ENGINEER  SIGNATURE _____ DATE 7/31/2015	ENGINEER  SIGNATURE _____ DATE _____
--	--

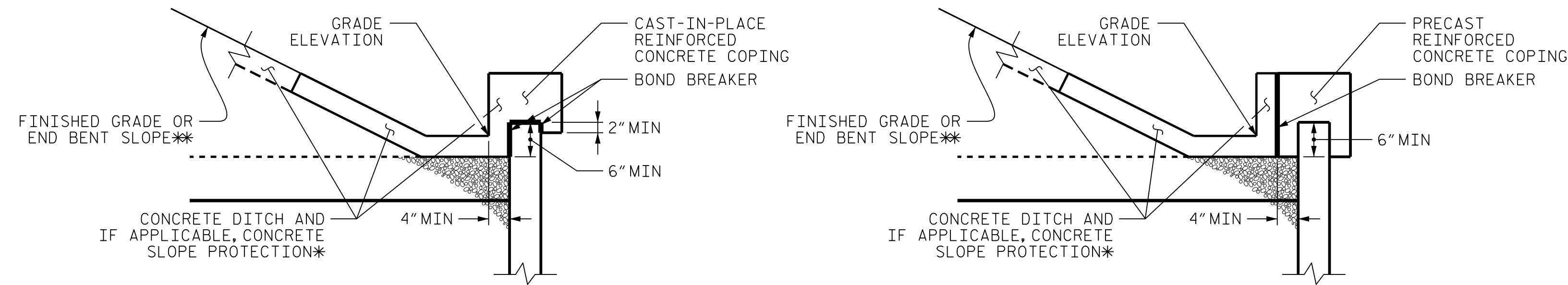

**COPING DETAILS**

\*SEE CONCRETE DITCH BEHIND WALL DETAILS.  
\*\*SEE PLANS FOR FINISHED GRADE OR END BENT SLOPE DETAILS.

**NOTES:**

FOR MECHANICALLY STABILIZED EARTH (MSE) RETAINING WALLS, SEE MECHANICALLY STABILIZED EARTH RETAINING WALLS PROVISION.

FOR SINGLE FACED PRECAST CONCRETE BARRIER, SEE ROADWAY PLANS AND SECTION 857 OF THE STANDARD SPECIFICATIONS.

USE AN MSE WALL SYSTEM WITH PRECAST CONCRETE PANELS THAT MEET SECTION 1077 OF THE STANDARD SPECIFICATIONS FOR RETAINING WALL NO. 1.

A DRAIN IS REQUIRED FOR RETAINING WALL NO. 1.

BEFORE BEGINNING MSE WALL DESIGN FOR RETAINING WALL NO. 1, SURVEY WALL LOCATION AND SUBMIT A REVISED WALL PROFILE VIEW (WALL ENVELOPE) FOR REVIEW. DO NOT START WALL DESIGN OR CONSTRUCTION UNTIL THE REVISED WALL ENVELOPE IS ACCEPTED.

- DESIGN RETAINING WALL NO. FOR THE FOLLOWING:
- 1) H = DESIGN HEIGHT + EMBEDMENT
  - 2) DESIGN LIFE = 100 YEARS
  - 3) MAXIMUM FACTORED VERTICAL STRESS ON FOUNDATION MATERIAL = 2,000 LB/SF
  - 4) MINIMUM REINFORCEMENT LENGTH (L) = 0.7 H OR 6 FT., WHICHEVER IS GREATER
  - 5) MINIMUM EMBEDMENT DEPTH = 2 FT
  - 6) AGGREGATE PARAMETERS:

AGGREGATE TYPE*	UNIT WEIGHT (γ) LB/CF	FRICTION ANGLE (φ) DEGREES	COHESION (c) LB/SF
COARSE	110	38	0
FINE	125	34	0

\*SEE MSE RETAINING WALLS PROVISION FOR COARSE AND FINE AGGREGATE MATERIAL REQUIREMENTS.

7) IN-SITU ASSUMED MATERIAL PARAMETERS:

MATERIAL TYPE	UNIT WEIGHT (γ) LB/CF	FRICTION ANGLE (φ) DEGREES	COHESION (c) LB/SF
BACKFILL	120	30	0
FOUNDATION	120	30	0

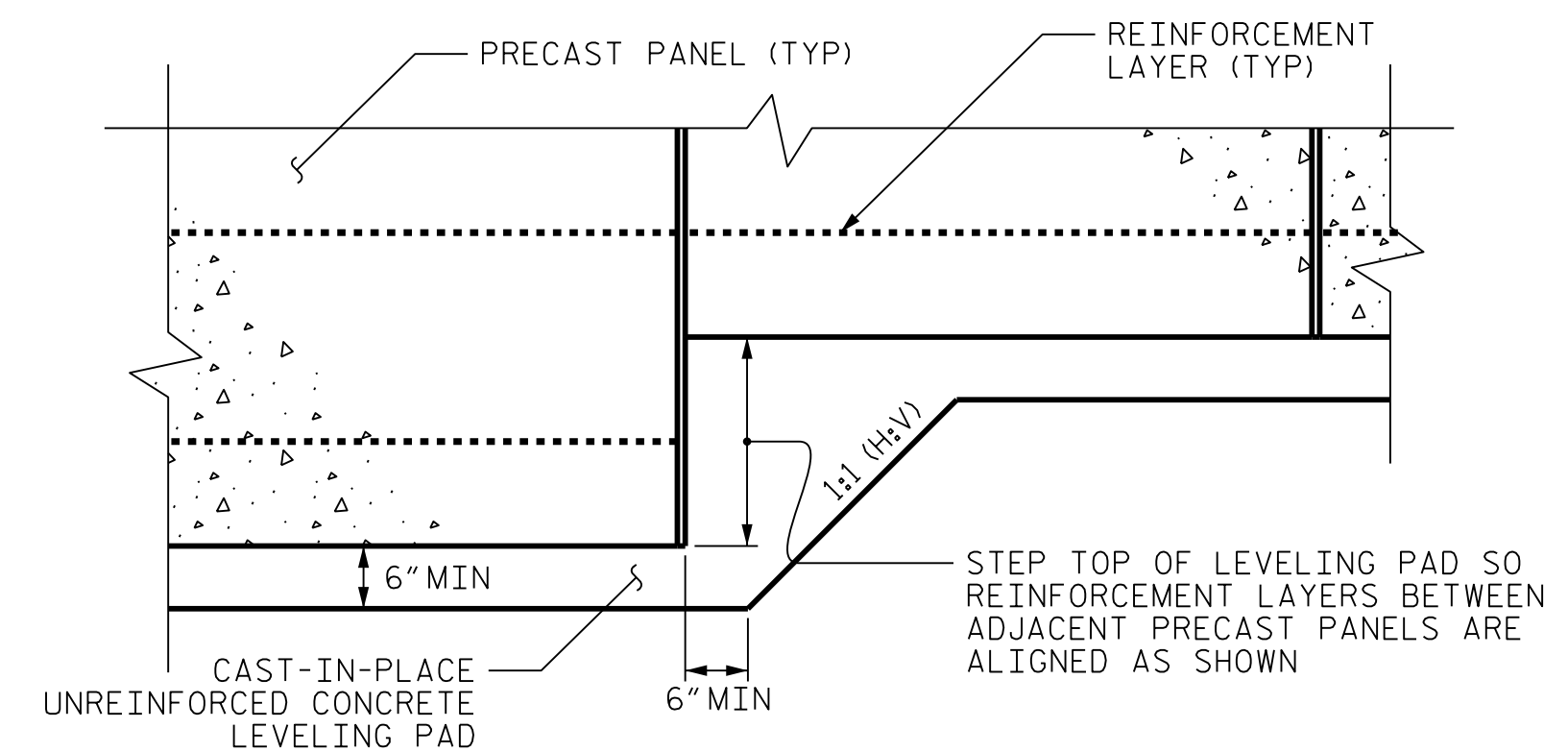

**PRECAST CONCRETE PANELS**

**LEVELING PAD STEP DETAILS**

DESIGN RETAINING WALL NO. 1 FOR A LIVE LOAD (TRAFFIC) SURCHARGE.

EXISTING OR FUTURE OBSTRUCTIONS SUCH AS FOUNDATIONS, GUARDRAIL, FENCE OR HANDRAIL POSTS, PAVEMENTS, PIPES, INLETS OR UTILITIES MAY INTERFERE WITH REINFORCEMENT FOR RETAINING WALL NO. 1.

DO NOT PLACE LEVELING PAD CONCRETE, AGGREGATE OR REINFORCEMENT FOR RETAINING WALL NO. 1 UNTIL EXCAVATION DIMENSIONS AND FOUNDATION MATERIAL ARE APPROVED.

AT THE CONTRACTOR'S OPTION, "TEMPORARY SHORING FOR WALL CONSTRUCTION" MAY BE USED TO CONSTRUCT RETAINING WALL NO. 1. SEE MSE RETAINING WALLS PROVISION FOR TEMPORARY SHORING FOR WALL CONSTRUCTION.

PROJECT NO.:           R-2915 A            
          WATAUGA / ASHE           COUNTY  
 STATION:           -RPB- 6+88.85 TO -RPB- 10+61.11            
 SHEET 3 OF 3

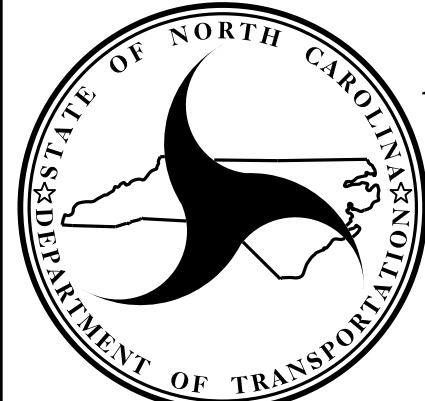

**NORTH CAROLINA  
DEPARTMENT OF TRANSPORTATION  
DIVISION OF HIGHWAYS**

**GEOTECHNICAL  
ENGINEERING UNIT**

**MECHANICALLY STABILIZED  
EARTH (MSE) RETAINING  
WALL NO. 1**

REVISIONS						SHEET NO. W-3
NO.	BY	DATE	NO.	BY	DATE	
1			3			
2			4			

PREPARED BY: MHS	DATE: 7/28/15
REVIEWED BY: SCC	DATE: 7/28/15

NAD 83 CORRS

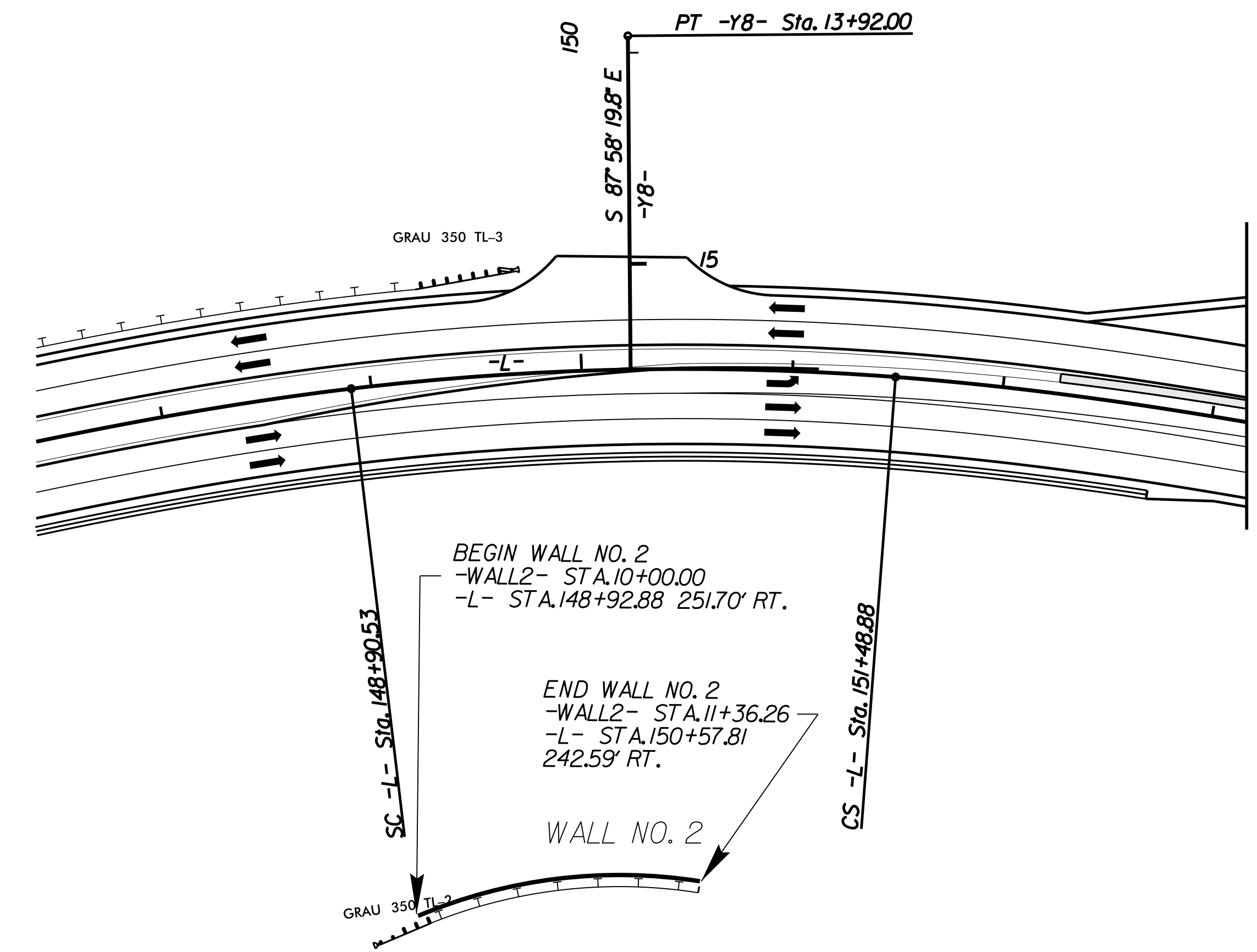

LOCATION SKETCH

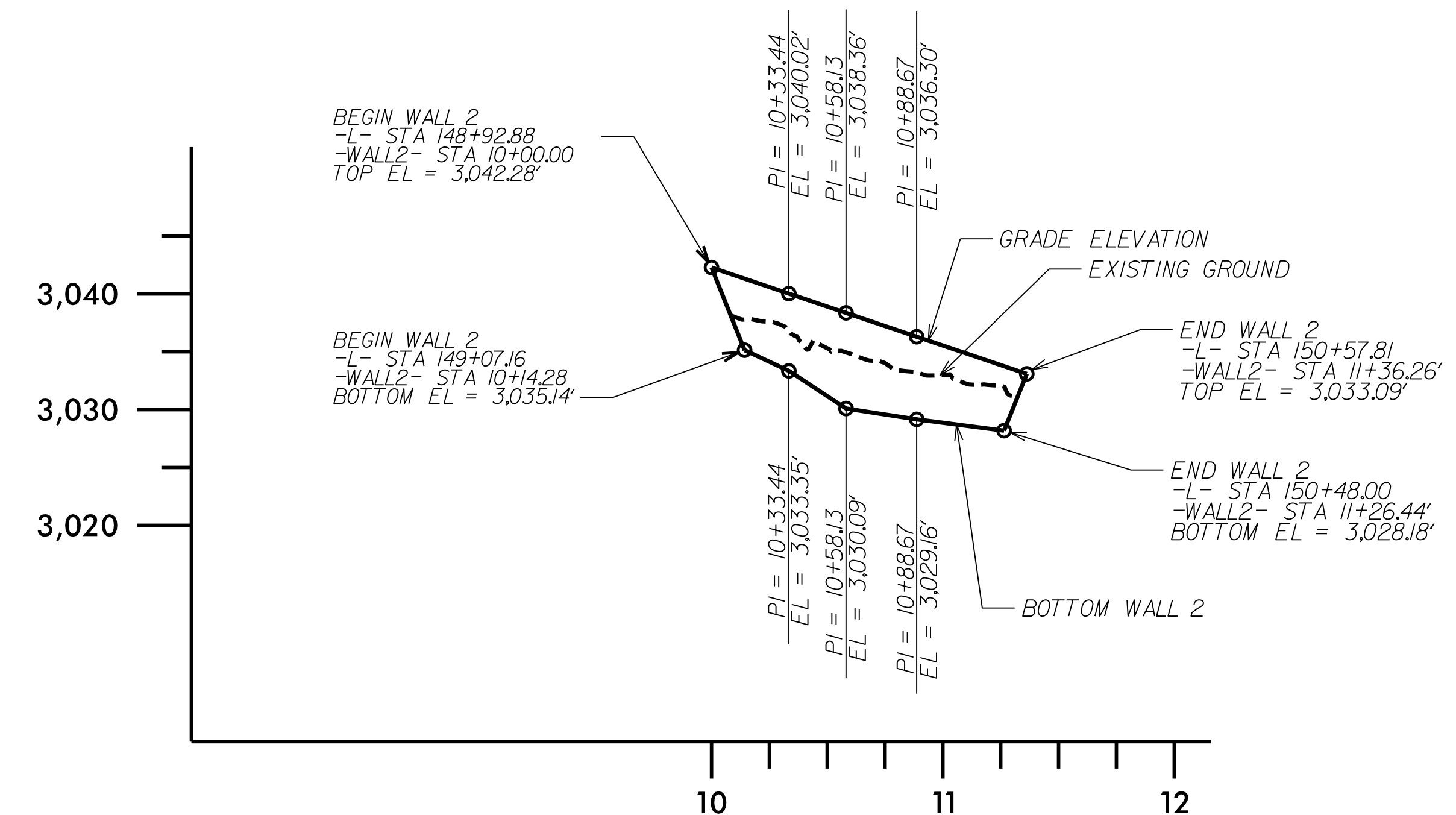

WALL ENEVELOPE

ESTIMATED MSE WALL QUANTITY  
(SQUARE FEET)

MSE RETAINING WALL NO. 2	1,250 +/- SF
--------------------------	--------------

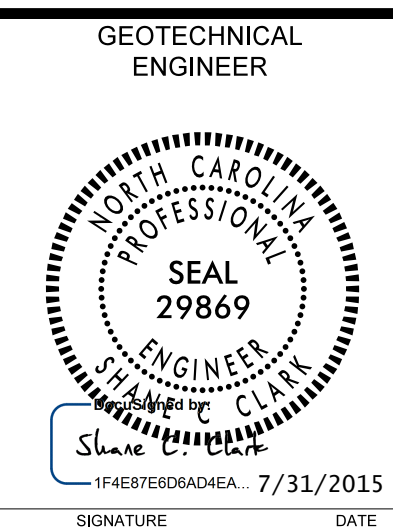

ENGINEER  
SIGNATURE \_\_\_\_\_ DATE \_\_\_\_\_

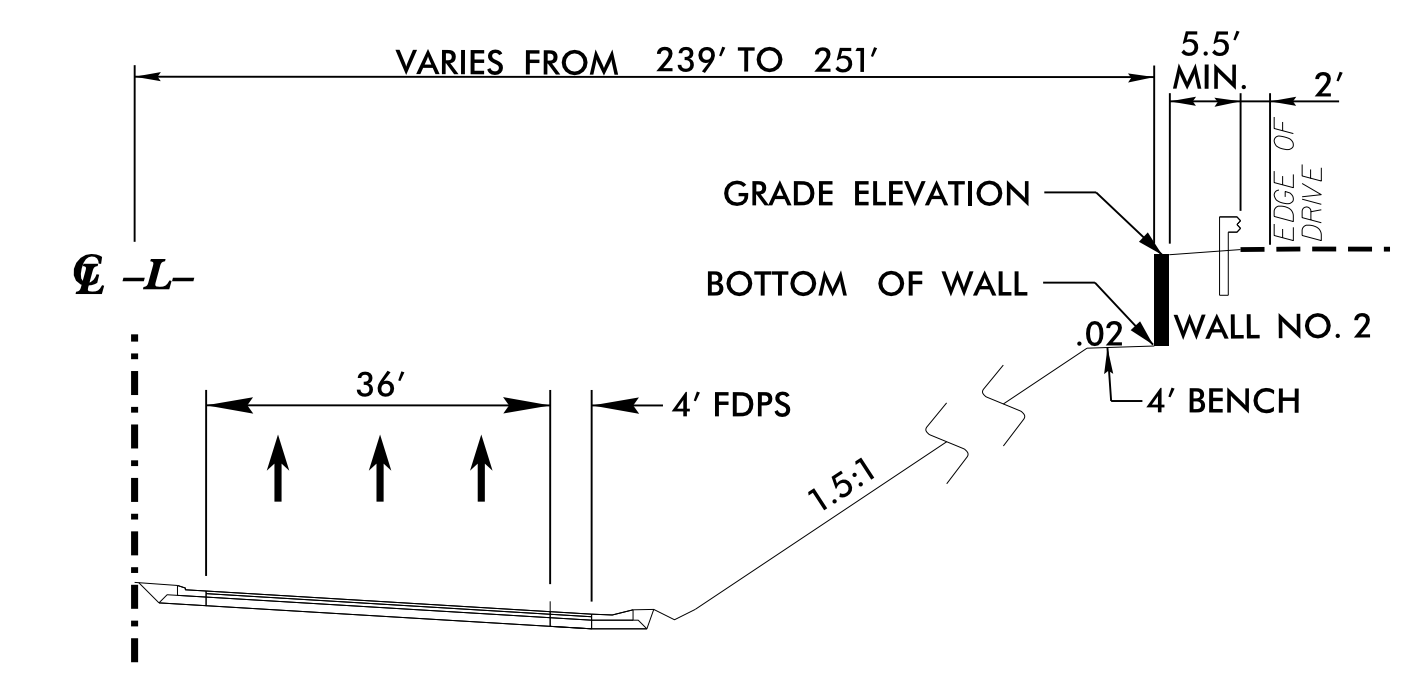

DETAIL B  
RETAINING WALL NO. 2  
-L- STA. 148+92.88 RT. TO STA. 150+57.81 RT.  
N.T.S.

PROJECT NO.: R-2915A  
WATAUGA / ASHE COUNTY  
STATION: 148+92.88 -L- TO 150+57.81 -L-, RT  
SHEET 1 OF 4



NORTH CAROLINA  
DEPARTMENT OF TRANSPORTATION  
DIVISION OF HIGHWAYS  
  
GEOTECHNICAL  
ENGINEERING UNIT

MECHANICALLY STABILIZED EARTH (MSE) RETAINING WALL NO. 2

REVISIONS						SHEET NO.
NO.	BY	DATE	NO.	BY	DATE	
1			3			W-4
2			4			

PREPARED BY: EJS DATE: 7-31-15  
REVIEWED BY: SCC DATE: 7-31-15

GEOTECHNICAL ENGINEER  SIGNATURE: <i>Shane C. Clark</i> DATE: 7/31/2015	ENGINEER    SIGNATURE: _____ DATE: _____
---	---

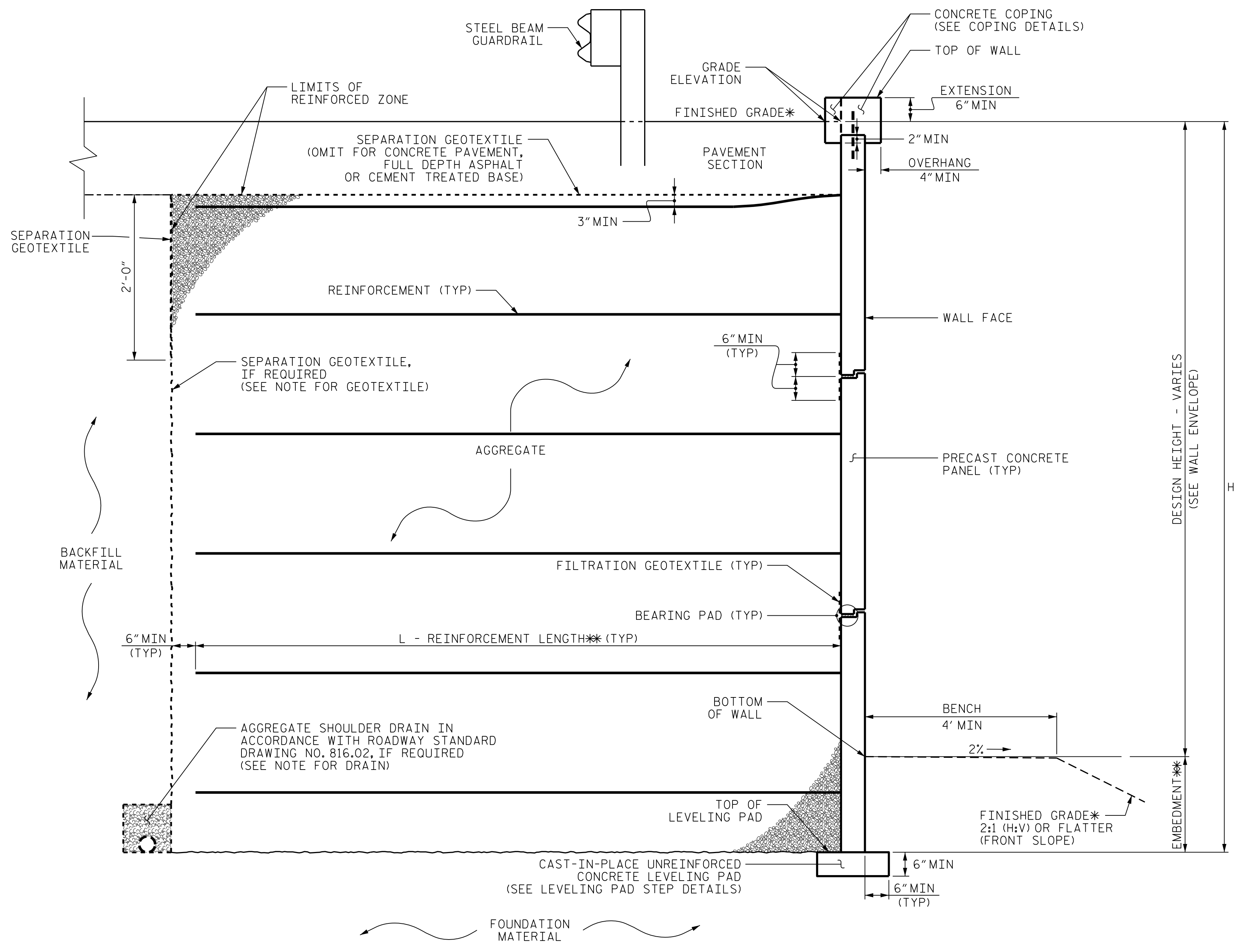

### MSE WALL WITH PRECAST PANELS - TYPICAL SECTION

\*SEE ROADWAY PLANS FOR FINISHED GRADE DETAILS.  
 \*\*SEE MSE RETAINING WALLS PROVISION AND IF APPLICABLE, MSE WALL NOTES FOR EMBEDMENT AND REINFORCEMENT LENGTH REQUIREMENTS.

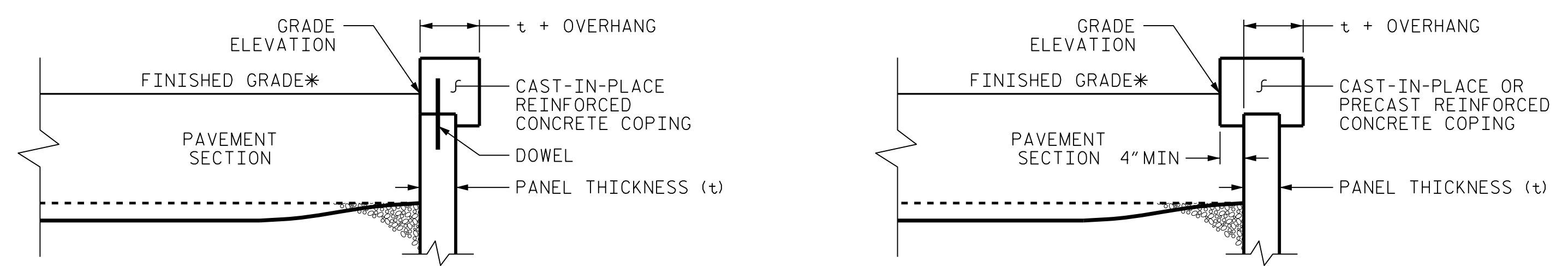

### COPING DETAILS

AT THE CONTRACTOR'S OPTION, CONNECT COPING TO PANELS WITH DOWELS OR EXTEND COPING DOWN BACK OF PANELS.  
 \*SEE ROADWAY PLANS FOR FINISHED GRADE DETAILS.

PROJECT NO.: R-2915AR-2915A  
 WATAUGA / ASHE COUNTY  
 STATION: 148+92.88 -L- TO 150+57.81 -L-, RT  
 SHEET 2 OF 4

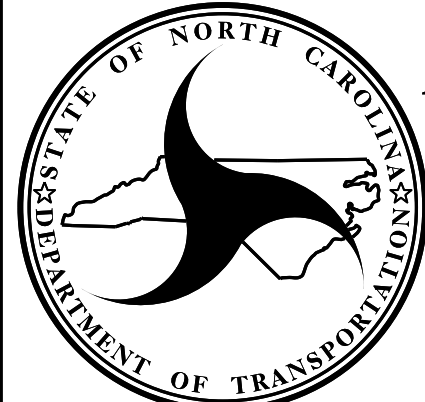

**NORTH CAROLINA**  
 DEPARTMENT OF TRANSPORTATION  
 DIVISION OF HIGHWAYS

**GEOTECHNICAL  
ENGINEERING UNIT**

MECHANICALLY STABILIZED EARTH (MSE) RETAINING WALL NO. 2					
REVISIONS					
NO.	BY	DATE	NO.	BY	DATE
1			3		
2			4		

PREPARED BY: SCC	DATE: 7-31-15
REVIEWED BY: EJS	DATE: 7-31-15

SHEET NO.  
W-5

GEOTECHNICAL ENGINEER  7/31/2015 SIGNATURE      DATE	ENGINEER          SIGNATURE      DATE
--	---

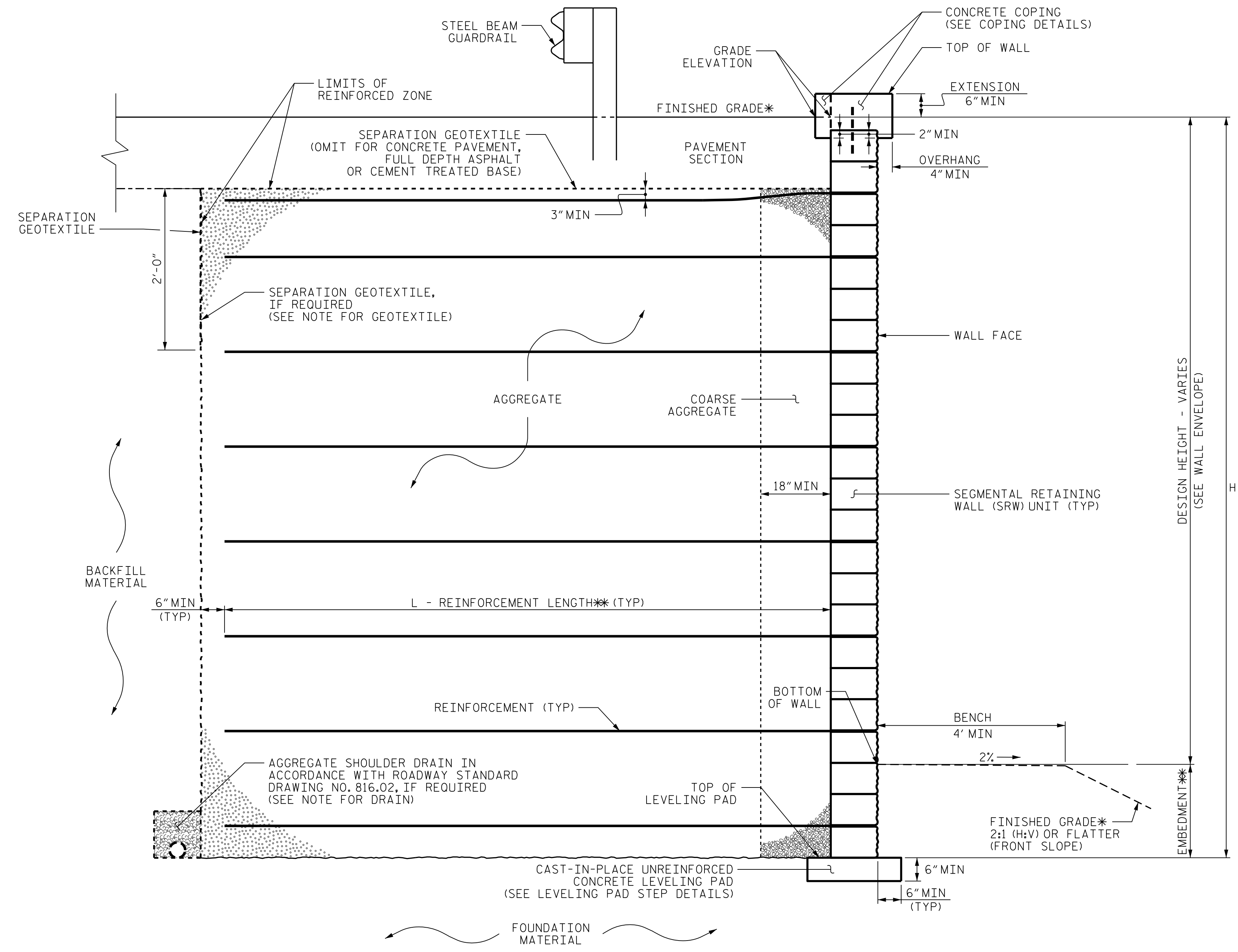

**MSE WALL WITH SRW UNITS - TYPICAL SECTION**

\*SEE ROADWAY PLANS FOR FINISHED GRADE DETAILS.  
 \*\*SEE MSE RETAINING WALLS PROVISION AND IF APPLICABLE, MSE WALL NOTES FOR EMBEDMENT AND REINFORCEMENT LENGTH REQUIREMENTS.

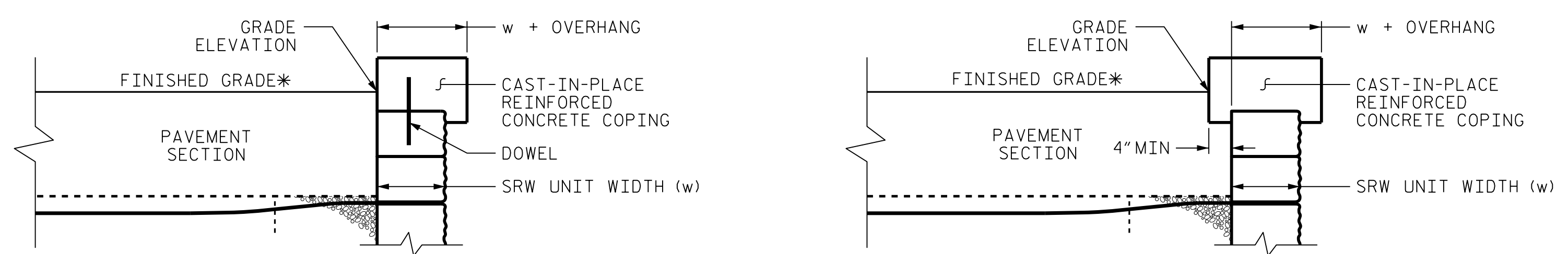

**COPING DETAILS**

AT THE CONTRACTOR'S OPTION, CONNECT COPING TO SRW UNITS WITH DOWELS OR EXTEND COPING DOWN BACK OF SRW UNITS.  
 \*SEE ROADWAY PLANS FOR FINISHED GRADE DETAILS.

PREPARED BY: SCC	DATE: 7-31-15
REVIEWED BY: EJS	DATE: 7-31-15

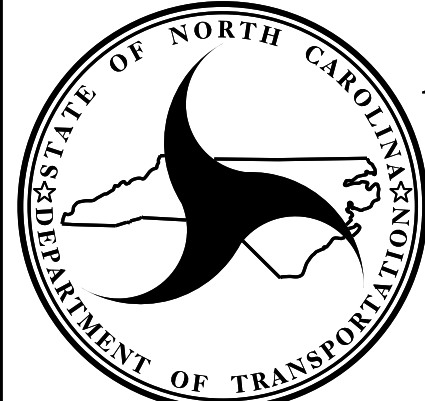
  
**NORTH CAROLINA**  
 DEPARTMENT OF TRANSPORTATION  
 DIVISION OF HIGHWAYS  
  
**GEOTECHNICAL**  
**ENGINEERING UNIT**

PROJECT NO.:           R-2915A            
          WATAUGA / ASHE           COUNTY  
 STATION: 148+92.88 -L- TO 150+57.81 -L-, RT  
 SHEET 3 OF 4

MECHANICALLY STABILIZED EARTH (MSE) RETAINING WALL NO. 2					
REVISIONS					
NO.	BY	DATE	NO.	BY	DATE
1			3		
2			4		

SHEET NO. W-6

GEOTECHNICAL ENGINEER  7/31/2015 SIGNATURE      DATE	ENGINEER          SIGNATURE      DATE
--	---

**NOTES:**

FOR MECHANICALLY STABILIZED EARTH (MSE) RETAINING WALLS, SEE MECHANICALLY STABILIZED EARTH RETAINING WALLS PROVISION.

FOR STEEL BEAM GUARDRAIL, SEE ROADWAY PLANS AND SECTION 862 OF THE STANDARD SPECIFICATIONS.

AT THE CONTRACTOR'S OPTION, USE AN MSE WALL SYSTEM WITH SEGMENTAL RETAINING WALL (SRW) UNITS THAT MEET ARTICLE 1040-4 OF THE STANDARD SPECIFICATIONS FOR RETAINING WALL NO. 2.

WHEN USING AN MSE WALL SYSTEM WITH SRW UNITS FOR RETAINING WALL NO. 2, FREEZE-THAW DURABLE SRW UNITS THAT MEET ARTICLE 1040-4 OF THE STANDARD SPECIFICATIONS ARE REQUIRED.

AT THE CONTRACTOR'S OPTION, USE FINE AGGREGATE IN THE REINFORCED ZONE OF RETAINING WALL NO. 2.

A SEPARATION GEOTEXTILE IS REQUIRED AT THE BACK OF THE REINFORCED ZONE FOR RETAINING WALL NO. 2.

A DRAIN IS REQUIRED FOR RETAINING WALL NO. 2.

BEFORE BEGINNING MSE WALL DESIGN FOR RETAINING WALL NO. 2, SURVEY WALL LOCATION AND SUBMIT A REVISED WALL PROFILE VIEW (WALL ENVELOPE) FOR REVIEW. DO NOT START WALL DESIGN OR CONSTRUCTION UNTIL THE REVISED WALL ENVELOPE IS ACCEPTED.

DESIGN RETAINING WALL NO. 2 FOR THE FOLLOWING:

- 1) H = DESIGN HEIGHT + EMBEDMENT
- 2) DESIGN LIFE = 75 YEARS
- 3) MAXIMUM FACTORED VERTICAL PRESSURE ON FOUNDATION MATERIAL = 3000 LB/SF
- 4) MINIMUM REINFORCEMENT LENGTH (L) = 0.7 OR 6 FT, WHICHEVER IS LONGER
- 5) MINIMUM EMBEDMENT ELEVATION = H/7, OR 2 FT, WHICHEVER IS GREATER
- 6) REINFORCED ZONE AGGREGATE PARAMETERS:

AGGREGATE TYPE*	UNIT WEIGHT (γ) LB/CF	FRICTION ANGLE (φ) DEGREES	COHESION (c) LB/SF
COARSE	110	38	0
FINE	115	34	0

\*SEE MSE RETAINING WALLS PROVISION FOR COARSE AND FINE AGGREGATE MATERIAL REQUIREMENTS.

7) IN-SITU ASSUMED MATERIAL PARAMETERS:

MATERIAL TYPE	UNIT WEIGHT (γ) LB/CF	FRICTION ANGLE (φ) DEGREES	COHESION (c) LB/SF
BACKFILL	120	30	0
FOUNDATION	120	30	0

DESIGN RETAINING WALL NO. 2 FOR A LIVE LOAD (TRAFFIC) SURCHARGE.

EXISTING OR FUTURE OBSTRUCTIONS SUCH AS FOUNDATIONS, GUARDRAIL, FENCE OR HANDRAIL POSTS, PAVEMENTS, PIPES, INLETS OR UTILITIES MAY INTERFERE WITH REINFORCEMENT FOR RETAINING WALL NO. 2.

DO NOT PLACE LEVELING PAD CONCRETE, AGGREGATE OR REINFORCEMENT FOR RETAINING WALL NO. 2 UNTIL EXCAVATION DIMENSIONS AND FOUNDATION MATERIAL ARE APPROVED.

AT THE CONTRACTOR'S OPTION, "TEMPORARY SHORING FOR WALL CONSTRUCTION" MAY BE USED TO CONSTRUCT RETAINING WALL NO. 2. SEE MSE RETAINING WALLS PROVISION FOR TEMPORARY SHORING FOR WALL CONSTRUCTION.

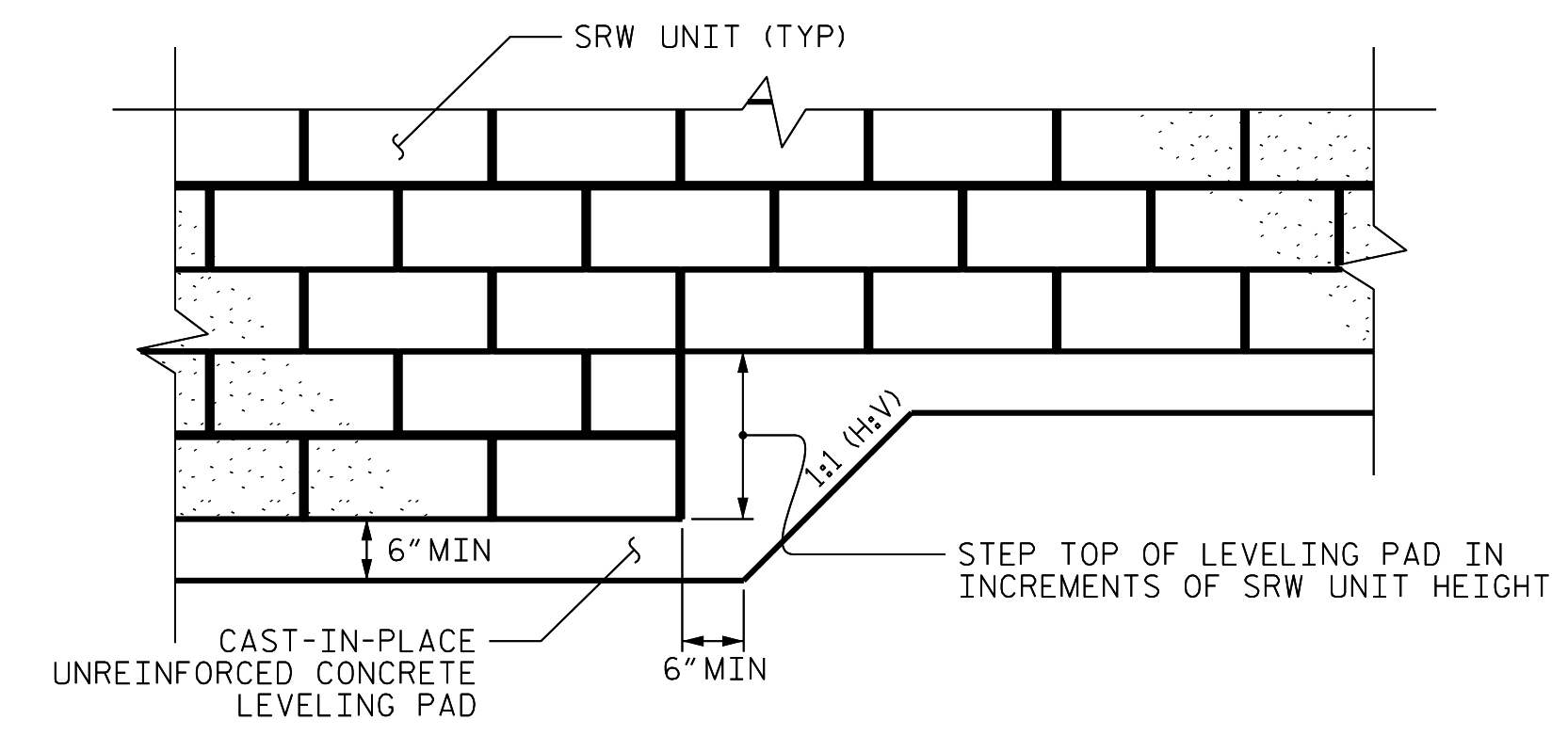

SEGMENTAL RETAINING WALL (SRW) UNITS

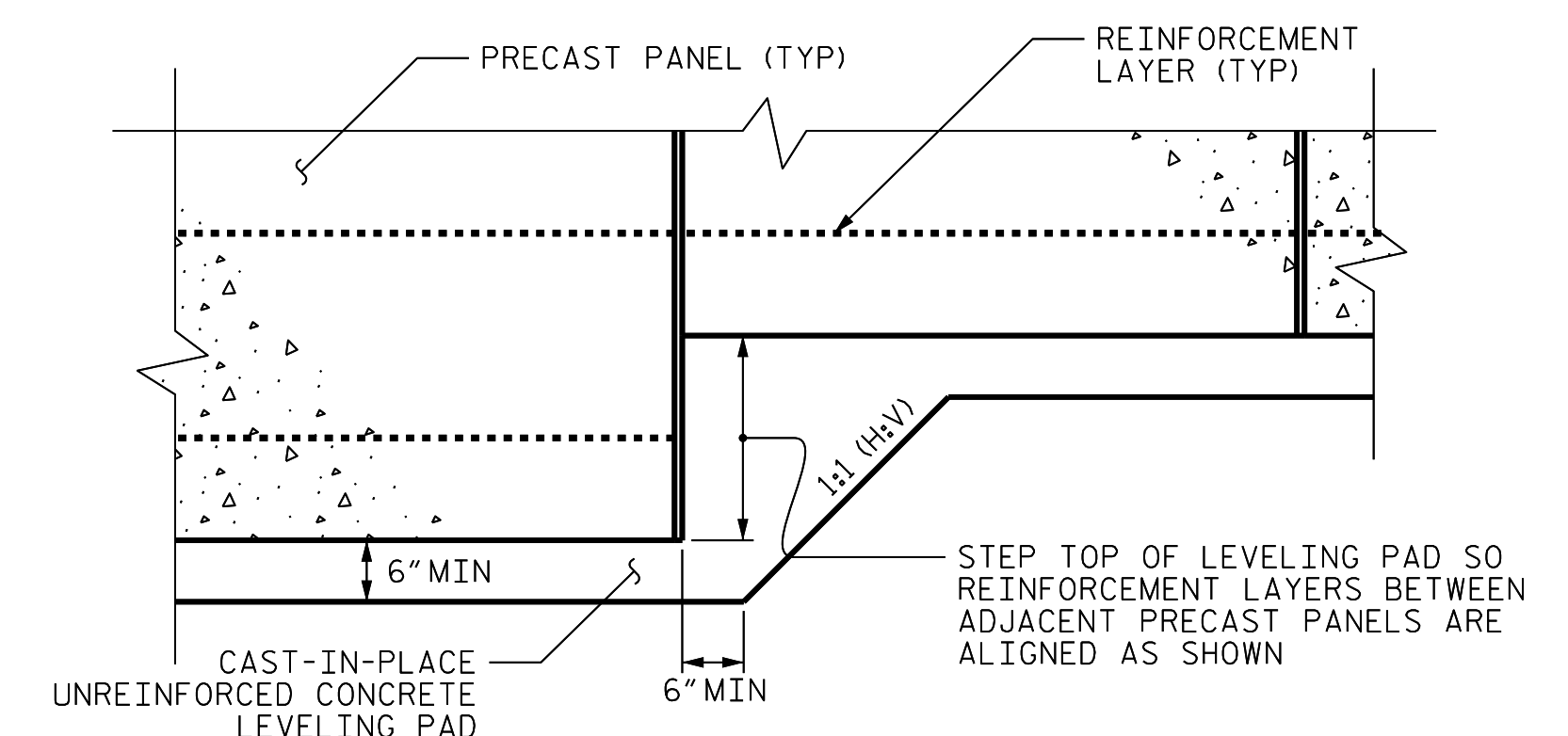

PRECAST CONCRETE PANELS

LEVELING PAD STEP DETAILS

PROJECT NO.: R-2915A  
 WATAUGA / ASHE COUNTY  
 STATION: 148+92.88 -L- TO 150+57.81 -L-, RT  
 SHEET 4 OF 4

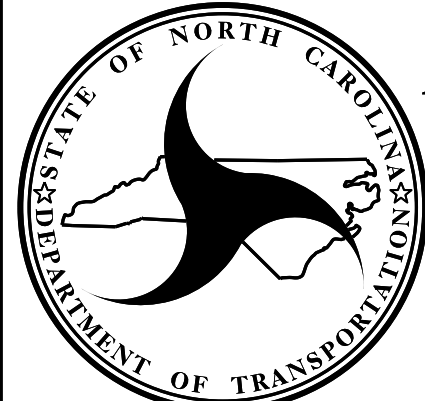
  
**NORTH CAROLINA**  
**DEPARTMENT OF TRANSPORTATION**  
**DIVISION OF HIGHWAYS**  
  
**GEOTECHNICAL**  
**ENGINEERING UNIT**

**MECHANICALLY STABILIZED EARTH (MSE) RETAINING WALL NO. 2**

REVISIONS						SHEET NO.
NO.	BY	DATE	NO.	BY	DATE	
1			3			W-7
2			4			

PREPARED BY: SCC	DATE: 7-31-15
REVIEWED BY: EJS	DATE: 7-31-15



## STANDARD NOTES

### DESIGN DATA:

SPECIFICATIONS	-----	A.A.S.H.T.O. (CURRENT)
LIVE LOAD	-----	SEE PLANS
IMPACT ALLOWANCE	-----	SEE A.A.S.H.T.O.
STRESS IN EXTREME FIBER OF		
STRUCTURAL STEEL - AASHTO M270 GRADE 36	-	20,000 LBS. PER SQ. IN.
- AASHTO M270 GRADE 50W	-	27,000 LBS. PER SQ. IN.
- AASHTO M270 GRADE 50	-	27,000 LBS. PER SQ. IN.
REINFORCING STEEL IN TENSION		
GRADE 60	--	24,000 LBS. PER SQ. IN.
CONCRETE IN COMPRESSION	-----	1,200 LBS. PER SQ. IN.
CONCRETE IN SHEAR	-----	SEE A.A.S.H.T.O.
STRUCTURAL TIMBER - TREATED OR		
UNTREATED - EXTREME FIBER STRESS	-----	1,800 LBS. PER SQ. IN.
COMPRESSION PERPENDICULAR TO GRAIN OF TIMBER	-----	375 LBS. PER SQ. IN.
EQUIVALENT FLUID PRESSURE OF EARTH	-----	30 LBS. PER CU. FT. (MINIMUM)

### MATERIAL AND WORKMANSHIP:

EXCEPT AS MAY OTHERWISE BE SPECIFIED ON PLANS OR IN THE SPECIAL PROVISIONS, ALL MATERIAL AND WORKMANSHIP SHALL BE IN ACCORDANCE WITH THE 2012 "STANDARD SPECIFICATIONS FOR ROADS AND STRUCTURES" OF THE N. C. DEPARTMENT OF TRANSPORTATION.

STEEL SHEET PILING FOR PERMANENT OR TEMPORARY APPLICATIONS SHALL BE HOT ROLLED.

### CONCRETE:

UNLESS OTHERWISE REQUIRED ON PLANS, CLASS A CONCRETE SHALL BE USED FOR ALL PORTIONS OF ALL STRUCTURES WITH THE EXCEPTION THAT: CLASS AA CONCRETE SHALL BE USED IN BRIDGE SUPERSTRUCTURES, ABUTMENT BACKWALLS, AND APPROACH SLABS; AND CLASS B CONCRETE SHALL BE USED FOR SLOPE PROTECTION AND RIP RAP.

### CONCRETE CHAMFERS:

UNLESS OTHERWISE NOTED ON THE PLANS, ALL EXPOSED CORNERS ON STRUCTURES SHALL BE CHAMFERED 3/4" WITH THE FOLLOWING EXCEPTIONS: TOP CORNERS OF CURBS MAY BE ROUNDED TO 1-1/2" RADIUS WHICH IS BUILT INTO CURB FORMS; CORNERS OF TRANSVERSE FLOOR EXPANSION JOINTS SHALL BE ROUNDED WITH A 1/4" FINISHING TOOL UNLESS OTHERWISE REQUIRED ON PLANS; AND CORNERS OF EXPANSION JOINTS IN THE ROADWAY FACES AND TOPS OF CURBS AND SIDEWALKS SHALL BE ROUNDED TO A 1/4" RADIUS WITH A FINISHING STONE OR TOOL UNLESS OTHERWISE REQUIRED ON PLANS.

### DOWELS:

DOWELS WHEN INDICATED ON PLANS AS FOR CULVERT EXTENSIONS, SHALL BE EMBEDDED AT LEAST 12" INTO THE OLD CONCRETE AND GROUTED INTO PLACE WITH 1:2 CEMENT MORTAR.

### ALLOWANCE FOR DEAD LOAD DEFLECTION, SETTLEMENT, ETC. IN CASTING SUPERSTRUCTURES:

BRIDGES SHALL BE BUILT ON THE GRADE OR VERTICAL CURVE SHOWN ON PLANS. SLABS, CURBS AND PARAPETS SHALL CONFORM TO THE GRADE OR CURVE.  
ALL DIMENSIONS WHICH ARE GIVEN IN SECTION AND ARE AFFECTED BY DEAD LOAD DEFLECTIONS ARE DIMENSIONS AT CENTER LINE OF BEARING UNLESS OTHERWISE NOTED ON PLANS. IN SETTING FORMS FOR STEEL BEAM BRIDGES AND PRESTRESSED CONCRETE GIRDER BRIDGES, ADJUSTMENTS SHALL BE MADE DUE TO THE DEAD LOAD DEFLECTIONS FOR THE ELEVATIONS SHOWN. WHERE BLOCKS ARE SHOWN OVER BEAMS FOR BUILDING UP TO THE SLAB, THE VERTICAL DIMENSIONS OF THE BLOCKS SHALL BE ADJUSTED BETWEEN BEARINGS TO COMPENSATE FOR DEAD LOAD DEFLECTIONS, VERTICAL CURVE ORDINATE, AND ACTUAL BEAM CAMBER. WHERE BOTTOM OF SLAB IS IN LINE WITH BOTTOM OF TOP FLANGES, DEPTH OF SLAB BETWEEN BEARINGS SHALL BE ADJUSTED TO COMPENSATE FOR DEAD LOAD DEFLECTION, VERTICAL CURVE ORDINATE, AND ACTUAL BEAM CAMBER.

IN SETTING FALSEWORK AND FORMS FOR REINFORCED CONCRETE SPANS, AN ALLOWANCE SHALL BE MADE FOR DEAD LOAD DEFLECTIONS, SETTLEMENT OF FALSEWORK, AND PERMANENT CAMBER WHICH SHALL BE PROVIDED FOR IN ADDITION TO THE ELEVATIONS SHOWN. AFTER REMOVAL OF THE FALSEWORK, THE FINISHED STRUCTURES SHALL CONFORM TO THE PROFILE AND ELEVATIONS SHOWN ON THE PLANS AND CONSTRUCTION ELEVATIONS FURNISHED BY THE ENGINEER.

DETAILED DRAWINGS FOR FALSEWORK OR FORMS FOR BRIDGE SUPERSTRUCTURE AND ANY STRUCTURE OR PARTS OF A STRUCTURE AS NOTED ON THE PLANS SHALL BE SUBMITTED TO THE ENGINEER FOR APPROVAL BEFORE CONSTRUCTION OF THE FALSEWORK OR FORMS IS STARTED.

### REINFORCING STEEL:

ALL REINFORCING STEEL SHALL BE DEFORMED. DIMENSIONS RELATIVE TO PLACEMENT OF REINFORCING ARE TO CENTERS OF BARS UNLESS OTHERWISE INDICATED IN THE PLANS. DIMENSIONS ON BAR DETAILS ARE TO CENTERS OF BARS OR ARE OUT TO OUT AS INDICATED ON PLANS.

WIRE BAR SUPPORTS SHALL BE PROVIDED FOR REINFORCING STEEL WHERE INDICATED ON THE PLANS. WHEN BAR SUPPORT PIECES ARE PLACED IN CONTINUOUS LINES, THEY SHALL BE SO PLACED THAT THE ENDS OF THE SUPPORTING WIRES SHALL BE LAPPED TO LOCK LEGS ON ADJOINING PIECES.

### STRUCTURAL STEEL:

AT THE CONTRACTOR'S OPTION, HE MAY SUBSTITUTE 7/8" Ø SHEAR STUDS FOR THE 3/4" Ø STUDS SPECIFIED ON THE PLANS. THIS SUBSTITUTION SHALL BE MADE AT THE RATE OF 3 - 7/8" Ø STUDS FOR 4 - 3/4" Ø STUDS, AND STUD SPACING CHANGES SHALL BE MADE AS NECESSARY TO PROVIDE THE SAME EQUIVALENT NUMBER OF 7/8" Ø STUDS ALONG THE BEAM AS SHOWN FOR 3/4" Ø STUDS BASED ON THE RATIO OF 3 - 7/8" Ø STUDS FOR 4 - 3/4" Ø STUDS. STUDS OF THE LENGTH SPECIFIED ON THE PLANS MUST BE PROVIDED. THE MAXIMUM SPACING SHALL BE 2'-0".

EXCEPT AT THE INTERIOR SUPPORTS OF CONTINUOUS BEAMS WHERE THE COVER PLATE IS IN CONTACT WITH BEARING PLATE, THE CONTRACTOR MAY, AT HIS OPTION, SUBSTITUTE FOR THE COVER PLATES DESIGNATED ON THE PLANS COVER PLATES OF THE EQUIVALENT AREA PROVIDED THESE PLATES ARE AT LEAST 5/16" IN THICKNESS AND DO NOT EXCEED A WIDTH EQUAL TO THE FLANGE WIDTH LESS 2" OR A THICKNESS EQUAL TO 2 TIMES THE FLANGE THICKNESS. THE SIZE OF FILLET WELDS SHALL CONFORM TO THE REQUIREMENTS OF THE CURRENT ANSI/AASHTO/AWS "BRIDGE WELDING CODE". ELECTROSLAG WELDING WILL NOT BE PERMITTED.

WITH THE SOLE EXCEPTION OF EDGES AT SURFACES WHICH BEAR ON OTHER SURFACES, ALL SHARP EDGES AND ENDS OF SHAPES AND PLATES SHALL BE SLIGHTLY ROUNDED BY SUITABLE MEANS TO A RADIUS OF APPROXIMATELY 1/16 INCH OR EQUIVALENT FLAT SURFACE AT A SUITABLE ANGLE PRIOR TO PAINTING, GALVANIZING, OR METALLIZING.

### HANDRAILS AND POSTS:

METAL STANDARDS AND FACES OF THE CONCRETE END POSTS FOR THE METAL RAIL SHALL BE SET NORMAL TO THE GRADE OF THE CURB, UNLESS OTHERWISE SHOWN ON PLANS. THE METAL RAIL AND TOPS OF CONCRETE POSTS USED WITH THE ALUMINUM RAIL SHALL BE BUILT PARALLEL TO THE GRADE OF THE CURB.  
METAL HANDRAILS SHALL BE IN ACCORDANCE WITH THE PLANS. RAILS SHALL BE AS MANUFACTURED FOR BRIDGE RAILING. CASTINGS SHALL BE OF A UNIFORM APPEARANCE. FINIS AND OTHER DEFORMATIONS RESULTING FROM CASTING OR OTHERWISE SHALL BE REMOVED IN A MANNER SO THAT A UNIFORM COLORING OF THE COMPLETED CASTING SHALL BE OBTAINED. CASTINGS WITH DISCOLORATIONS OR OF NON-UNIFORM COLORING WILL NOT BE ACCEPTED. CERTIFIED MILL REPORTS ARE REQUIRED FOR METAL RAILS AND POSTS.

### SPECIAL NOTES:

GENERALLY, IN CASE OF DISCREPANCY, THIS STANDARD SHEET OF NOTES SHALL GOVERN OVER THE SPECIFICATIONS, BUT THE REMAINDER OF THE PLANS SHALL GOVERN OVER NOTES HEREON, AND SPECIAL PROVISIONS SHALL GOVERN OVER ALL. SEE SPECIFICATIONS ARTICLE 105-4.

# ENGLISH

JANUARY, 1990