

**NOTES:**  
 INSTALL THE 4" DIA. DRAIN PIPE THROUGH THE WING WALL AS REQUIRED FOR REINFORCED BRIDGE APPROACH FILLS. SEE THE ROADWAY PLANS. REINFORCING STEEL IN THE WING WALL MAY BE SHIFTED AS NECESSARY TO CLEAR THE DRAIN PIPE.  
 #4 D1 BARS MAY BE SHIFTED SLIGHTLY TO AVOID STIRRUPS IN CAP.  
 SEE SUPERSTRUCTURE SHEETS FOR UPPER PART OF INTEGRAL END BENT DETAILS.

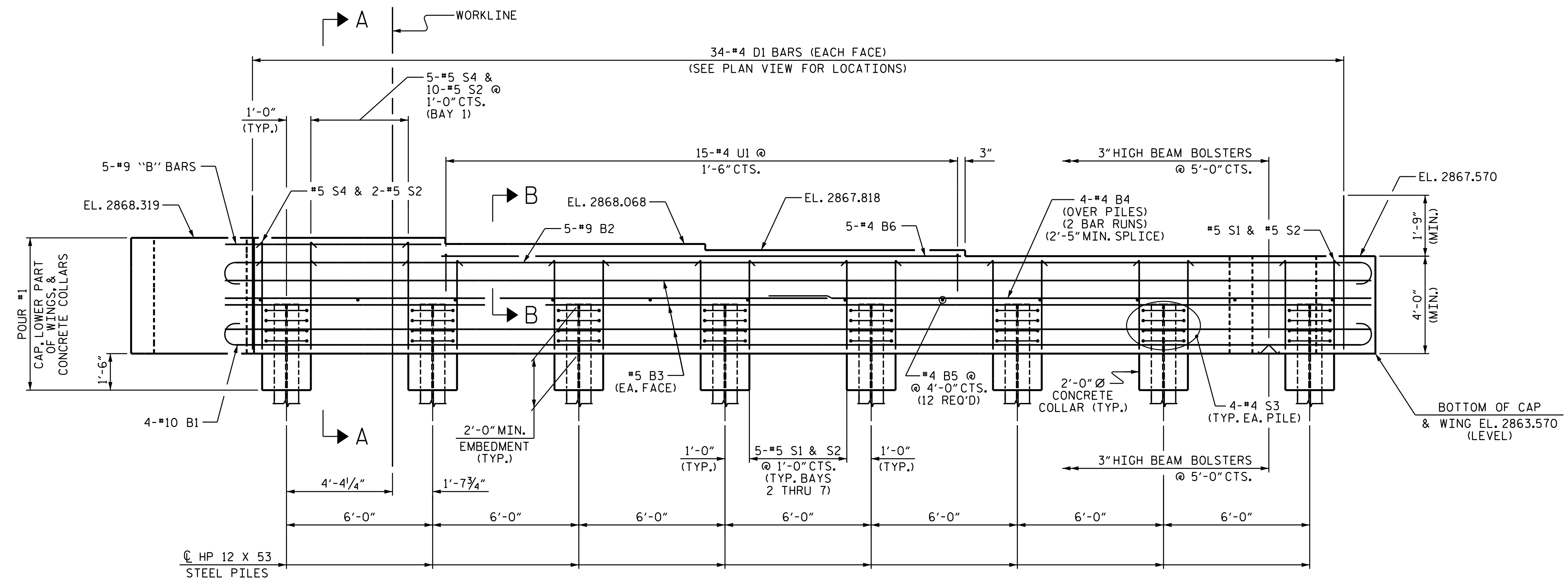
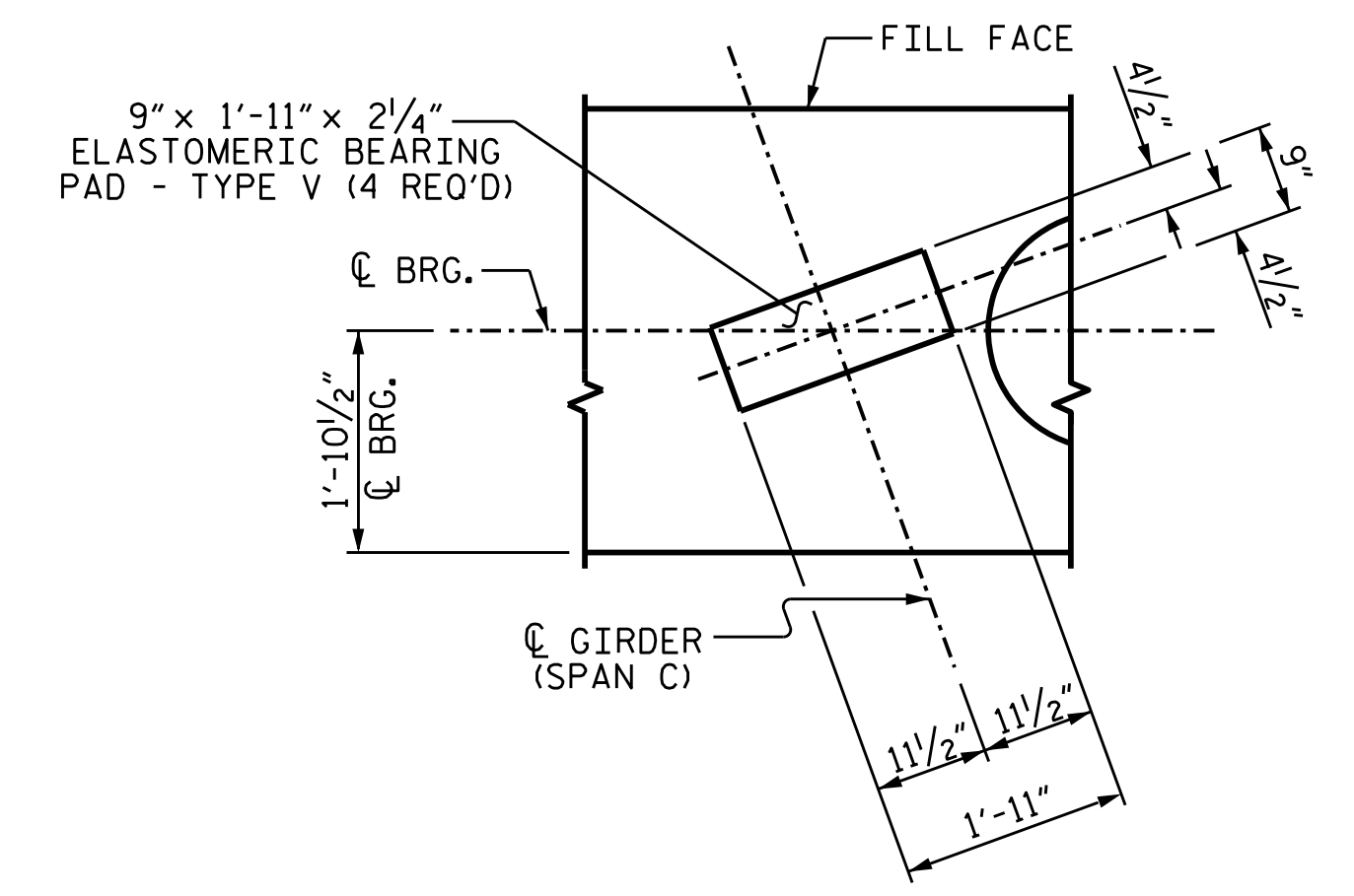
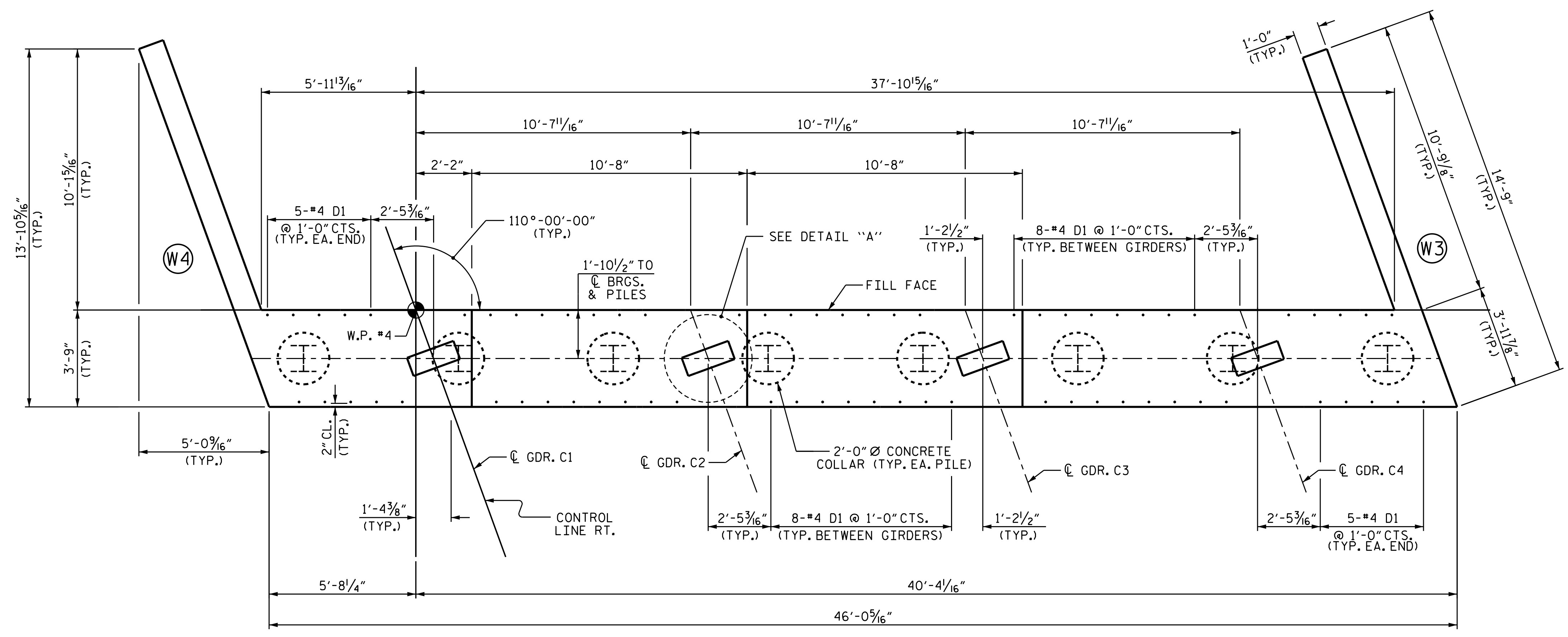

PROJECT NO. R-2915B  
ASHE COUNTY  
 STATION: 242+67.42 -L-  
 SHEET 1 OF 3

STATE OF NORTH CAROLINA  
 DEPARTMENT OF TRANSPORTATION  
 RALEIGH  
 SUBSTRUCTURE  
 INTEGRAL  
 END BENT #2  
 NBL

REVISIONS						SHEET NO.	
NO.	BY:	DATE:	NO.	BY:	DATE:	S05-30	
1			3			TOTAL SHEETS	
2			4			35	

DRAWN BY : T.J. KIRSCHBAUM DATE : 10/13/14  
 CHECKED BY : E.E. DEETSCHRECK DATE : 11/10/14  
 DESIGN ENGINEER OF RECORD : R.F. WERTMAN DATE : 11/13/14

PLANS PREPARED BY:  
**Gannett Fleming**  
 Excellence Delivered As Promised  
 1121 Situs Court  
 Suite 170  
 Raleigh, NC 27606-4279  
 (919) 859-4880  
 NCLic. No. F-0270

