

AT INTERMEDIATE DIAPHRAGM
TYPICAL SECTION
AT BENT DIAPHRAGM

SHEET LEGEND

- Ø RADIAL DIMENSION
- (A) 3-#4 U1 & 3-#4 S1 @ 11" CTS. (TYP. EA. SIDE)
- (B) 11" (TYP. EA. SIDE)
- (C) 2-#4 S2 @ 11" CTS. (TYP. EA. SIDE)
- (D) 2-1" Δ DRIP GROOVES (TYP. EA. OVERHANG)
- (E) 2-#5 B8 @ 6" CTS. BOTTOM OF SLAB 4 BAR RUN (TYP. EA. OVERHANG)
- (F) 3-#4 B.B.U. (LEFT OVERHANG) 3" B.B.U. (RIGHT OVERHANG)
- (G) 3-#5 B7 @ 7" CTS. BOTTOM OF SLAB 4 BAR RUN (TYP. EA. OVERHANG)

NOTES

PROVIDE 1/4" HIGH BEAM BOLSTERS UPPER AT 4'-0" CTS. ATOP THE METAL STAY-IN-PLACE FORMS TO SUPPORT THE BOTTOM MAT OF "A" BARS. WHEN USING REMOVABLE FORMS, PROVIDE CONTINUOUS HIGH CHAIRS FOR METAL DECK (CHCM) AT 4'-0" CTS. WITH A HEIGHT TO SUPPORT THE BOTTOM MAT OF "A" BARS A CLEAR DISTANCE OF 2 1/2" ABOVE THE TOP OF THE REMOVABLE FORM.

LONGITUDINAL STEEL MAY BE SHIFTED SLIGHTLY, AS NECESSARY, TO AVOID INTERFERENCE WITH STIRRUPS IN PRESTRESSED CONCRETE GIRDERS.

PREVIOUSLY CAST CONCRETE IN A CONTINUOUS UNIT SHALL HAVE ATTAINED A MINIMUM COMPRESSIVE STRENGTH OF 3,000 PSI BEFORE ADDITIONAL CONCRETE IS CAST IN THE UNIT.

BARRIER RAIL IN A CONTINUOUS UNIT SHALL NOT BE CAST UNTIL ALL SLAB CONCRETE IN THAT UNIT HAS BEEN CAST AND HAS REACHED A MINIMUM COMPRESSIVE STRENGTH OF 3,000 PSI.

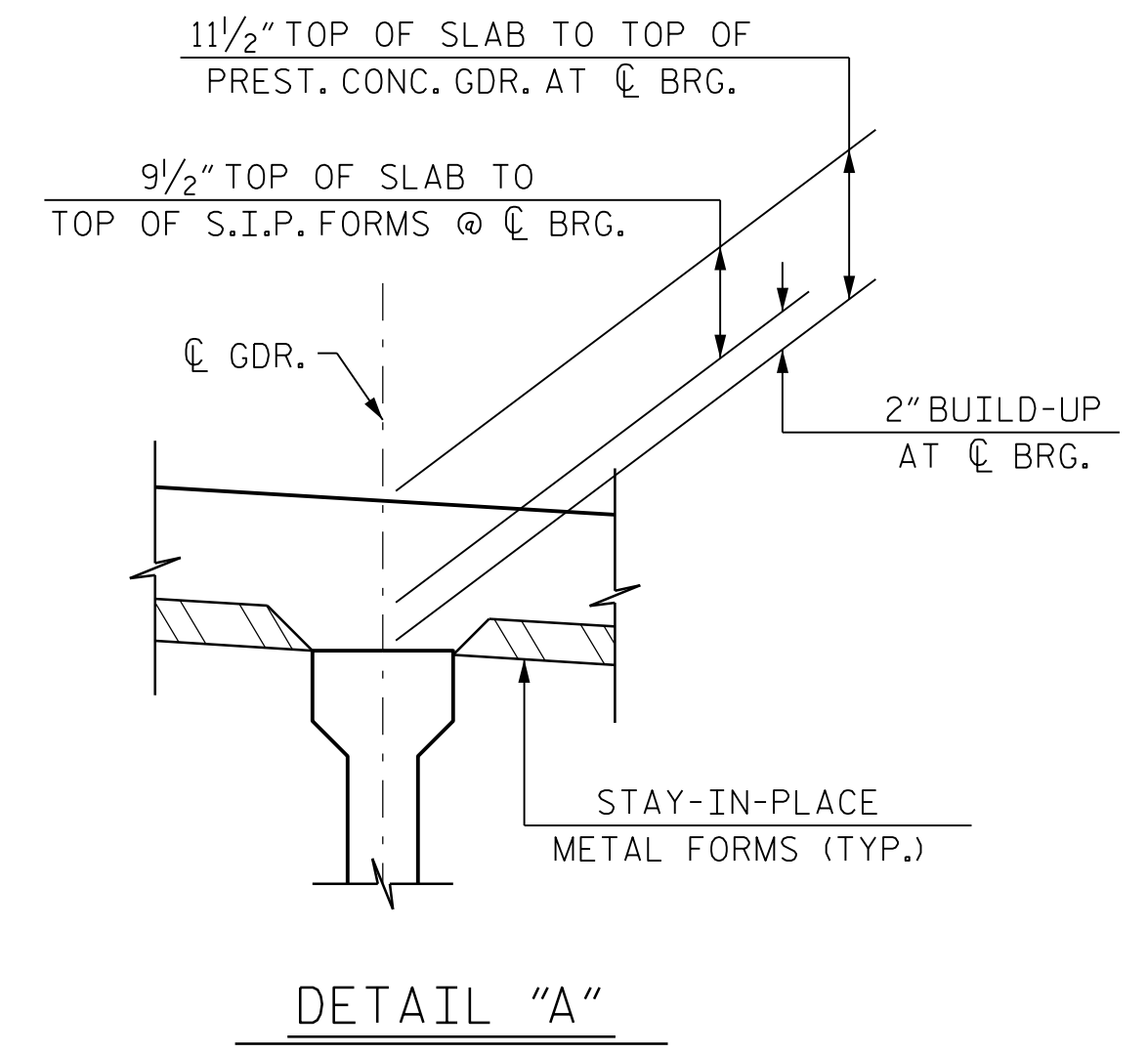

DETAIL "A"

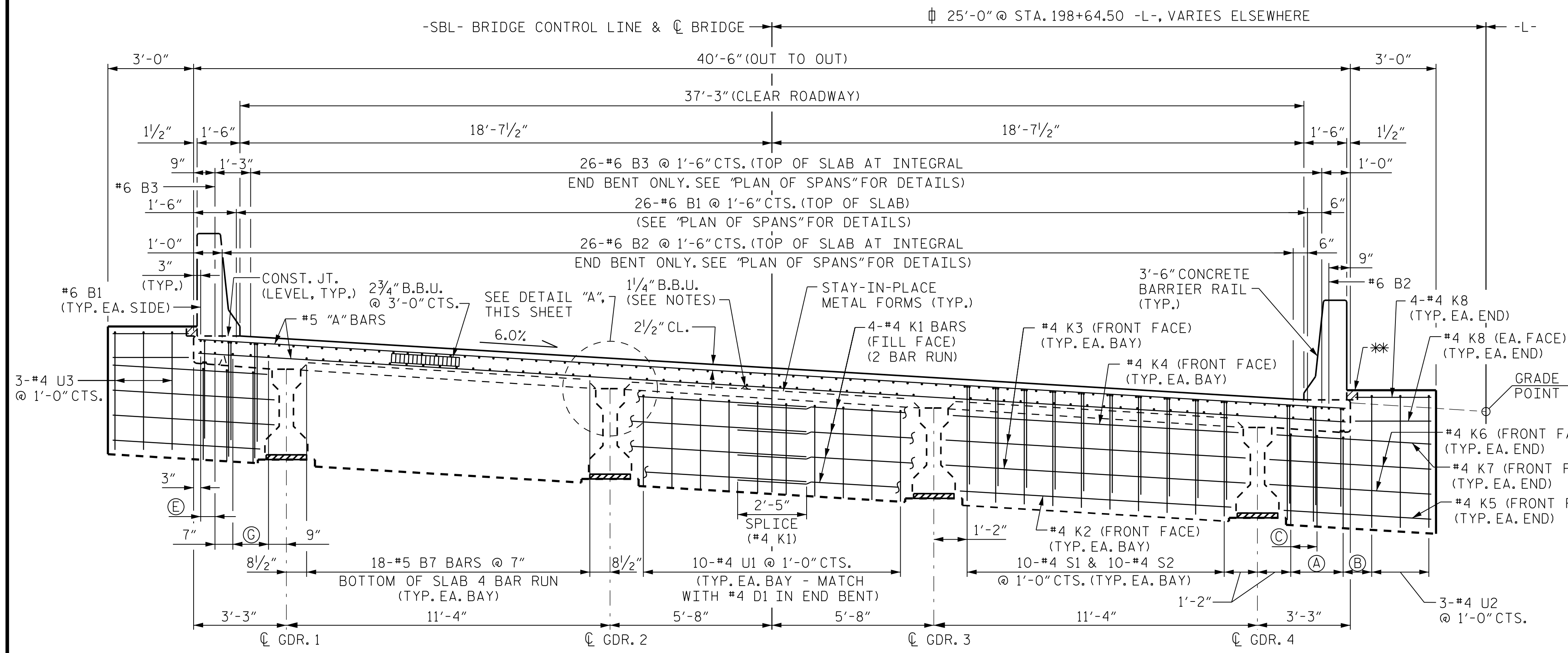

TYPICAL SECTION AT INTEGRAL END BENT

* THE CONCRETE IN THE HATCHED AREA OF THE INTEGRAL END BENT DIAPHRAGM SHALL BE POURED AFTER THE BARRIER IS CAST IF SLIP FORMING IS USED. SEE SHEET "PLAN OF SPAN DETAILS" FOR BLOCKOUT GEOMETRY. (TYP. EA. SIDE)

PROJECT NO. R-2915B
ASHE COUNTY
STATION: 198+64.50 -L-

SHEET 1 OF 2

STATE OF NORTH CAROLINA
DEPARTMENT OF TRANSPORTATION
RALEIGH

SUPERSTRUCTURE
TYPICAL SECTION
(SBL)

CDM Smith
CDM SMITH
5400 Glenwood Avenue, Suite 400
Raleigh, NC 27612-3228
NC COA No. F-1255

DRAWN BY: J. SLOAN
CHECKED BY: J. TAYLOR
DESIGN ENGINEER: J. TAYLOR

DATE: 04-14
DATE: 07-14
DATE: 08-14

DWG. No.

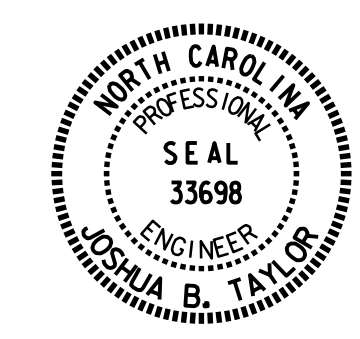

REVISIONS		SHEET No.	
No.	BY:	DATE:	No.
1			3
2			4

S01-6	
TOTAL SHEETS	34

FILE: R:\med\192915B Structures\PLANS\Bridges 1 SBL\2915B_S01_TS_01.dgn
DATE: 11/22/14 2:57:01 PM