

PLAN

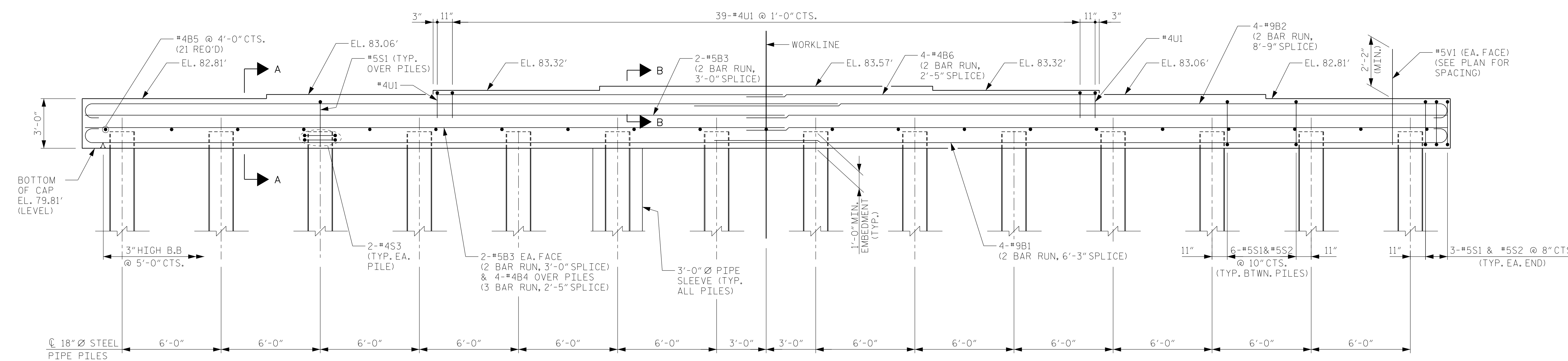

ELEVATION

NOTES

- FOR PILE SPLICE DETAILS, SEE "END BENT 1 (INTEGRAL)" SHEET 3 OF 3.
- SEE SUPERSTRUCTURE SHEETS FOR UPPER PORTION OF INTEGRAL END BENT DETAILS.
- THE TOP SURFACE OF THE END BENT CAP, EXCEPT THE BEARING AREA, SHALL BE RAKED TO A DEPTH OF 1/4".
- FOR PIPE SLEEVE DETAIL, SEE "GENERAL DRAWING" SHEET 2 OF 3.

PROJECT NO. U-3315
PITT COUNTY
 STATION: 65+56.61 -L-
16+96.14 -Y10-
 SHEET 1 OF 3

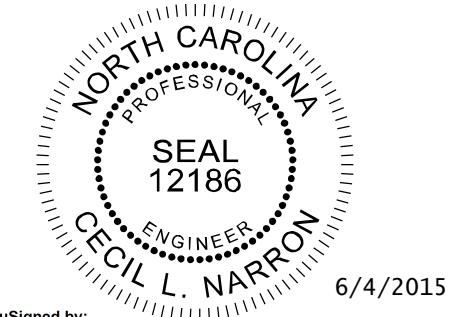

Kimley»Horn
 333 Fayetteville Street, Suite 600
 Raleigh, NC 27601-1772
 Phone (919) 835-1494
 NC LICENSE # F-0102

STATE OF NORTH CAROLINA DEPARTMENT OF TRANSPORTATION RALEIGH					
SUBSTRUCTURE END BENT 1 (INTEGRAL)					
REVISIONS					
NO.	BY:	DATE:	NO.	BY:	DATE:
1			3		
2			4		
SHEET NO. S-24					TOTAL SHEETS 33

K:\BIDI_Structures\Bridges\NC\011036175_U3315-10th-St_Greenville\Cad\egm\24.dgn 6/4/2015

DRAWN BY: <u>J. I. KIMBLE</u>	DATE: <u>5/15</u>
CHECKED BY: <u>J. C. WILSON</u>	DATE: <u>5/15</u>
DESIGN ENGINEER OF RECORD: <u>C.L. NARRON</u>	DATE: <u>5/15</u>