

**EDI MODEL MMU2-16LE  
MALFUNCTION MANAGEMENT UNIT  
PROGRAMMING DETAIL**  
*(program card and tables as shown below)*

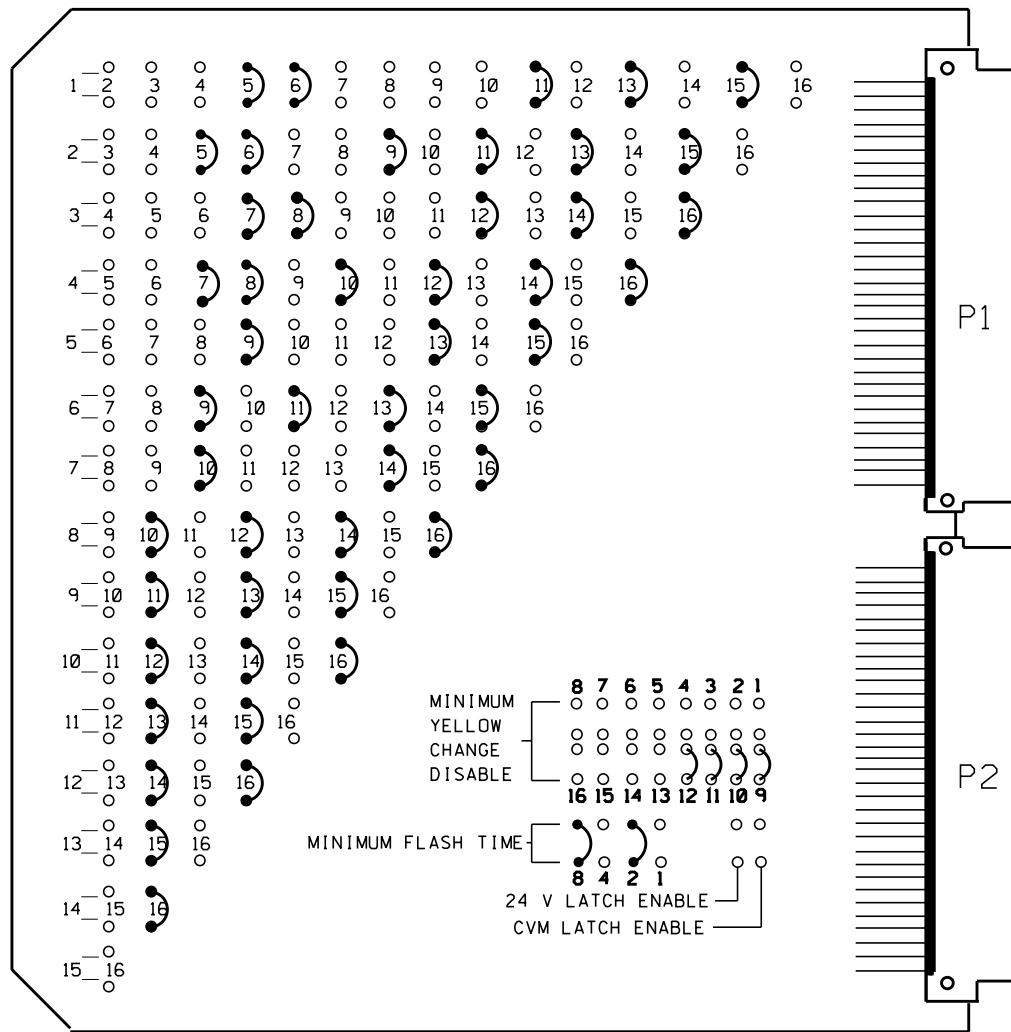

MMU PROGRAMMING CARD

CHANNEL NUMBER	ENABLE/DISABLE
1	ENABLE
2	ENABLE
3	ENABLE
4	ENABLE
5	ENABLE
6	ENABLE
7	ENABLE
8	ENABLE
9	ENABLE
10	ENABLE
11	ENABLE
12	ENABLE
13	ENABLE
14	ENABLE
15	ENABLE
16	ENABLE

**MMU PROGRAMMING NOTE**  
ENSURE YELLOW CHANGE PLUS RED CLEARANCE MONITORING IS ENABLED FOR ALL CHANNELS.

OPTION	SETTING
RECURRENT PULSE	ON
WALK DISABLE	OFF
LOG CVM FAULTS	ON
EXTERN WATCHDOG	OFF
24V-2=12VDC	OFF
PGM CARD MEMORY	ON
LEDguard	ON
FORCE TYPE 16	OFF
TYPE12-SOLC	OFF
VM 3x/Day Latch	ON

FLASHING YELLOW ARROW	
CONFIG MODE	A
ENABLE CHANNEL PAIR, FYA	
CH 1-9	ON
CH 3-10	ON
CH 5-11	ON
CH 7-12	ON
RED/YEL INPUT ENABLE	
CH 1-9	OFF
CH 3-10	OFF
CH 5-11	OFF
CH 7-12	OFF
FLASH RATE FAULT	OFF
FYA TRAP DETECT	OFF

**NOTES**

- To prevent "Flash-conflict" problems, wire all unused load switches to flash red. Verify that signal heads flash in accordance with the signal plans.
- Program controller to start up in phases 2 and 6 green.
- Set power-up flash time to 10 seconds and implement on the Malfunction Management Unit. Set controller power-up flash time to 0 seconds.
- Enable simultaneous gap-out feature, on controller unit, for all phases.
- Program detectors in accordance with the manufacturer's instructions to accomplish the detection schemes shown on the signal design plans.
- Program detector call delay and extension timing on the controller, unless otherwise specified.
- Set all detector card unit channels to "presence" mode.
- Program phases 4 and 8, on controller unit, for dual entry.
- This controller and cabinet are part of the Greenville Signal System.

**SIGNAL HEAD HOOK-UP CHART**

PHASE	1	2	3	4	5	6	7	8	2 PED	4 PED	6 PED	8 PED	OLA	OLB	OLC	OLD		
SIGNAL HEAD NO.	11*	82	21,22	22	31*	41,42	51*	61,62	71*	81,82	P21, P22	P41, P42	P61, P62	P81, P82	11*	31*	51*	71*
RED	*	2R		*	4R	*	6R	*	8R									
YELLOW		2Y			4Y	*	6Y	*	8Y									
GREEN		2G			4G		6G		8G									
RED ARROW															13R	14R	15R	16R
YELLOW ARROW		1Y	3Y												13Y	14Y	15Y	16Y
FLASHING YELLOW ARROW															13G	14G	15G	16G
GREEN ARROW	1G	1G	3G	3G	5G		7G											
Hand icon										9R	10R	11R	12R					
Person icon										9G	10G	11G	12G					

NU = Not Used  
\*Denotes install load resistor, see load resistor installation detail this sheet.  
\*See pictorial of head wiring detail this sheet.

**DETECTOR RACK SET-UP DETAIL**

INSERT DETECTOR CARDS IN RACK ACCORDING TO THE DETAIL SHOWN BELOW. PARTICULAR DETECTOR CHANNELS WILL CALL PHASES INDICATED.

DETECTOR RACK #1	CHI	CHI	CHI	CHI	CHI	CHI	CHI	SLOT	SLOT	SLOT	SLOT
BIU	L3	L1	L7	L5	L11	L9	L15	EMPTY	EMPTY	EMPTY	EMPTY
	Ø1	Ø1	Ø3	Ø2	Ø5	Ø4	Ø6				
BIU	CH2	CH2	CH2	CH2	CH2	CH2	CH2	EMPTY	EMPTY	EMPTY	EMPTY
	L4	L2	L8	L6	L12	L10	L16				
	NOT USED	Ø6	Ø8	NOT USED	Ø2	Ø4	NOT USED				

HALF DETECTOR RACK #2	CHI	CHI	SLOT	SLOT
BIU	L19	L17	EMPTY	EMPTY
	Ø8	Ø7		
BIU	CH2	CH2	EMPTY	EMPTY
	L20	L18		
	Ø8	Ø4		

WIRE LOOPS TO TERMINALS ON LOOP PANEL AS SHOWN IN THE CHART BELOW

LOOP NO.	LOOP PANEL TERMINALS	NOTE
1A	L1A, L1B L2A, L2B	ADD JUMPERS FROM L1A TO L2A AND L1B TO L2B
1B	L3A, L3B	
NU	L4A, L4B	
2A, 2B	L5A, L5B	
NU	L6A, L6B	
3A	L7A, L7B L8A, L8B	ADD JUMPERS FROM L7A TO L8A AND L7B TO L8B
4A	L9A, L9B	
4B	L10A, L10B	
5A	L11A, L11B L12A, L12B	ADD JUMPERS FROM L11A TO L12A AND L11B TO L12B
NU	L13A, L13B	
NU	L14A, L14B	
6A, 6B	L15A, L15B	
NU	L16A, L16B	
7A	L17A, L17B L18A, L18B	ADD JUMPERS FROM L17A TO L18A AND L17B TO L18B
8A	L19A, L19B	
8B	L20A, L20B	
NU	L21A, L21B	
NU	L22A, L22B	
NU	L23A, L23B	
NU	L24A, L24B	

NU = NOT USED

**NOTE**  
BE SURE TO PROGRAM DETECTOR TYPES AND TIMERS (EXTEND AND DELAY) AS SHOWN ON THE SIGNAL PLANS.

PROGRAM CONTROLLER DETECTORS ACCORDING TO THE SCHEDULE SHOWN IN THE CHART BELOW

CONTROLLER DETECTOR NO.	FUNCTION	TIMING	
		FEATURE	TIME(SEC)
1	Ø1	DELAY	15
2	Ø6	-	-
3	Ø1	DELAY	15
4	-	-	-
5	Ø2	-	-
6	-	-	-
7	Ø3	DELAY	15
8	Ø8	DELAY	3
9	Ø4	-	-
10	Ø4	DELAY	10
11	Ø5	DELAY	15
12	Ø2	-	-
13	-	-	-
14	-	-	-
15	Ø6	-	-
16	-	-	-
17	Ø7	DELAY	15
18	Ø4	DELAY	3
19	Ø8	-	-
20	Ø8	-	-
21	-	-	-
22	-	-	-
23	-	-	-
24	-	-	-

**EQUIPMENT INFORMATION**

CONTROLLER.....ASC/3  
CABINET .....NC-8A TS-2  
SOFTWARE .....ECONOLITE ASC/ 2070  
CABINET MOUNT.....BASE  
LOADBAY POSITIONS.....16  
LOAD SWITCHES USED.....1,2,3,4,5,6,7,8,9,10,11,12,13,14,15,16  
PHASES USED.....1,2,2PED,3,4,4PED,5,6,6PED,7,8,8PED  
OLA.....\*  
OLB.....\*  
OLC.....\*  
OLD.....\*  
\* See Sheet 2 of 2 Econolite ASC/2070 Overlap Programming Detail.

**LOAD RESISTOR INSTALLATION DETAIL**

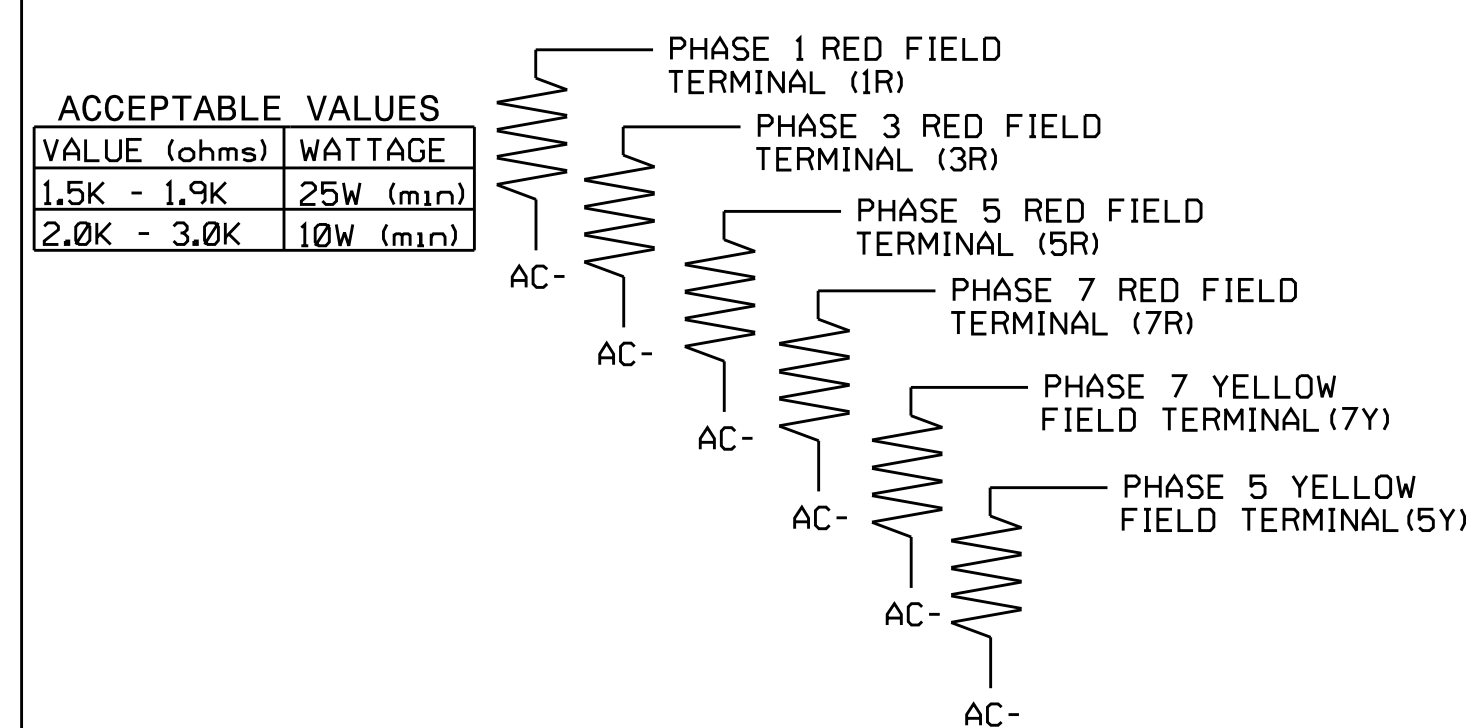

VALUE (ohms)	WATTAGE
1.5K - 1.9K	25W (min)
2.0K - 3.0K	10W (min)

**4 SECTION FYA PPLT SIGNAL WIRING DETAIL**

*(wire signal heads as shown)*

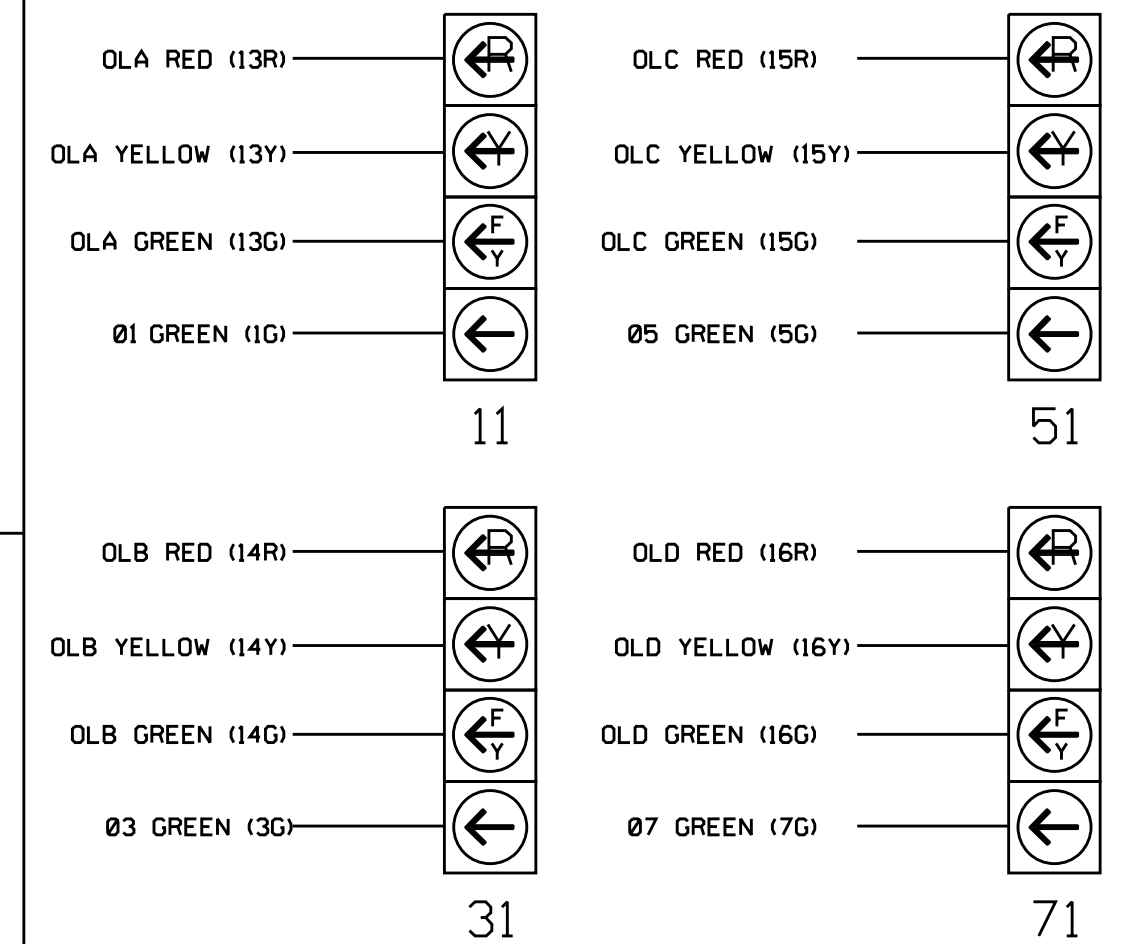

**NOTE**  
1. SEE OVERLAP PROGRAMMING INSTRUCTIONS SHEET 2 OF 2.

THIS ELECTRICAL DETAIL IS FOR THE SIGNAL DESIGN: 02-0016  
DESIGNED: JUNE 2014  
SEALED: 9/2/2014  
REVISED: N/A

FINAL DESIGN

SHEET 1 OF 2

ELECTRICAL AND PROGRAMMING DETAILS FOR:



PLANS PREPARED IN THE OFFICE OF:  
**Kimley-Horn**  
NC License #F-0102  
P.O. Box 33068  
Raleigh, NC 27636  
(919) 617-2000

SR 1598 (10th STREET) AT SR 1702 (EVANS STREET)

DIVISION 2 PITT COUNTY GREENVILLE

PLAN DATE: JUNE 2014 REVIEWED BY: SL PHILLIPS

PREPARED BY: SP PENNINGTON REVIEWED BY:

REVISIONS	INIT.	DATE

DocuSigned by: **Stacie Phillips** 9/2/2014

SIGNATURE DATE

SIG. INVENTORY NO. 02-0016