

**-Y7A-**  
 PI Sta 17+68.49  
 $\Delta = 75^\circ 31' 38.7''$  (RT)  
 $D = 15^\circ 26' 37.0''$   
 $L = 489.05'$   
 $T = 287.40'$   
 $R = 371.00'$

**131**  
 WILMINGTON HOSPITALITY LLC  
 DB 2708 PG 332  
 DB 4129 PG 57  
 DB 3095 PG 280  
 MB 45 PG 104

**130A**  
 MARKET STREET VENTURES, LLC  
 DB 5695 PG 588  
 MB 4 PG 80

**130A**  
 MARKET STREET VENTURES, LLC  
 DB 5695 PG 588  
 MB 4 PG 80

**63**  
 GENEVA C. EDGE  
 DB 1441 PG 192  
 DB 817 PG 706  
 MB 4 PG 80

**62**  
 MORRIS R. SKIPPER, ET UX  
 DB 1215 PG 272  
 DB 1214 PG 1884  
 MB 4 PG 80

**62**  
 MORRIS R. SKIPPER, ET UX  
 DB 1215 PG 272  
 DB 1214 PG 1884  
 MB 4 PG 80

**130**  
 PREVATTE PROPERTIES, LLC  
 DB 5695 PG 594  
 MB 4 PG 80

**58**  
 NORTH KERR OFFICE COA, INC.  
 DB 1286 PG 143  
 DB 1308 PG 1013  
 CB 7 PG 167  
 CB 7 PG 168  
 MB 4 PG 80

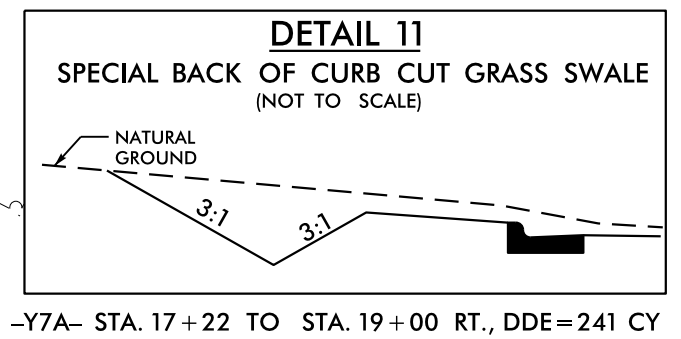
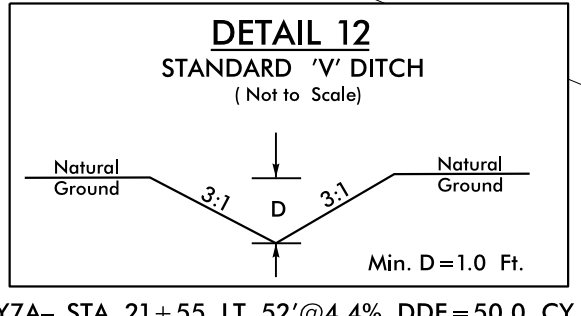

REVISIONS

MATCHLINE -Y7A- STA.17+25 SEE SHEET 35

MATCHLINE -Y7A- STA.22+50 SEE SHEET 29

29 JAN-2015 08:44  
 33338b\_rdl\_psh\_s36.dgn