

CLTWater STANDARD DETAILS

0400DEL_P30

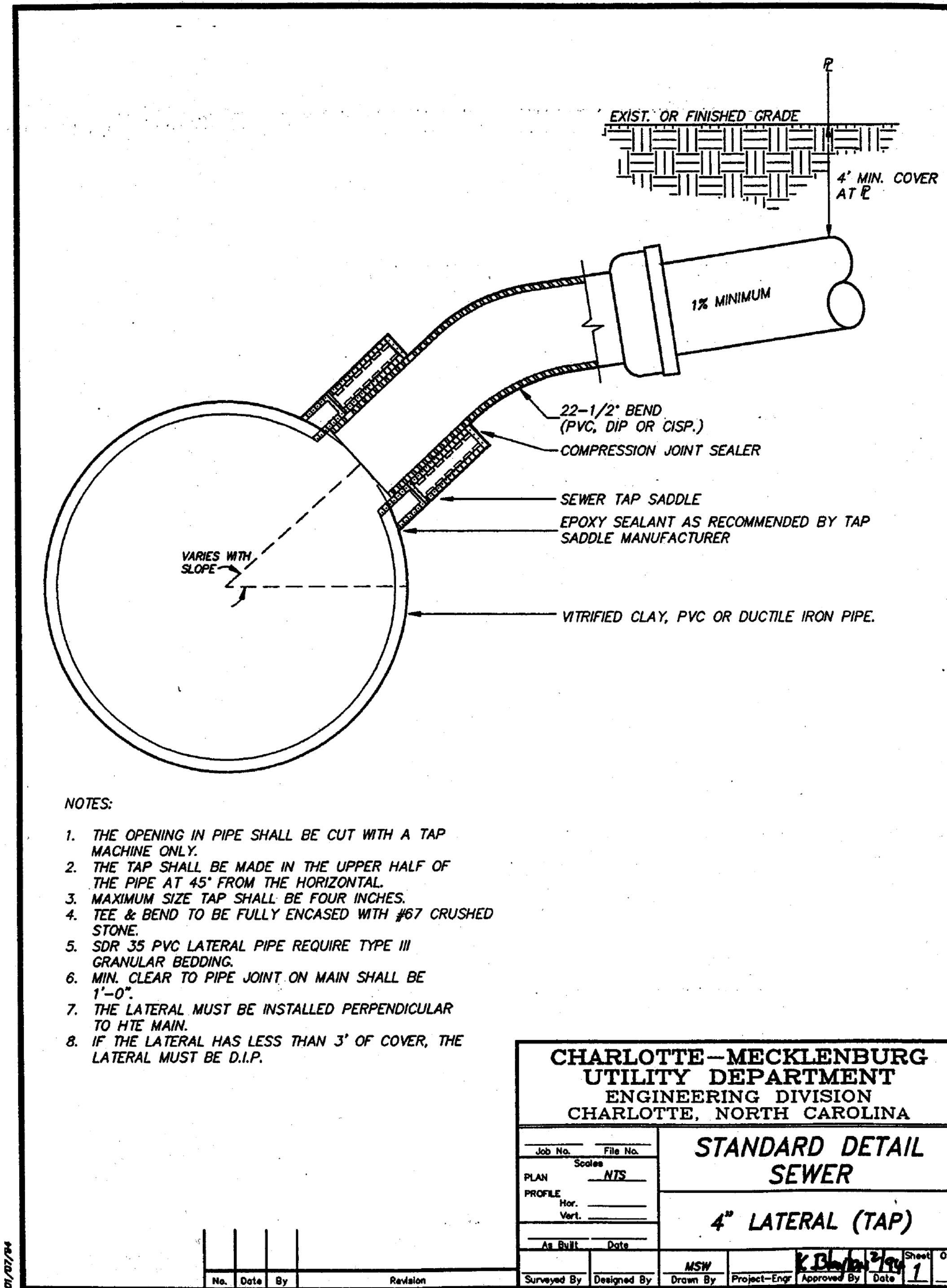

July 27, 1995 XV-57 Sewer Specifications/Details (SD)

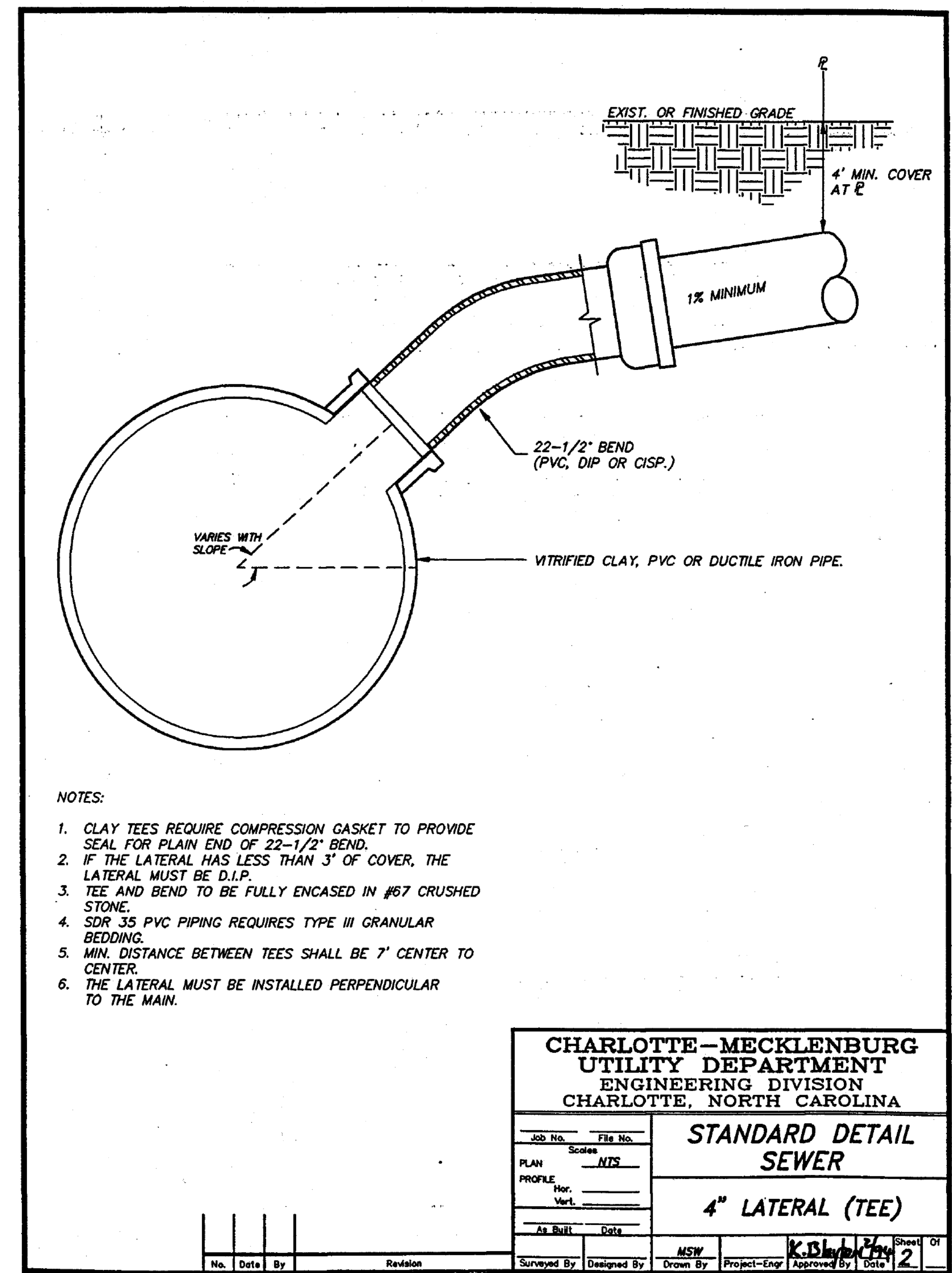

July 27, 1995 XV-58 Sewer Specifications/Details (SD)