

EDI MODEL 2010ECL-NC CONFLICT MONITOR PROGRAMMING DETAIL

(remove jumpers and set switches as shown)

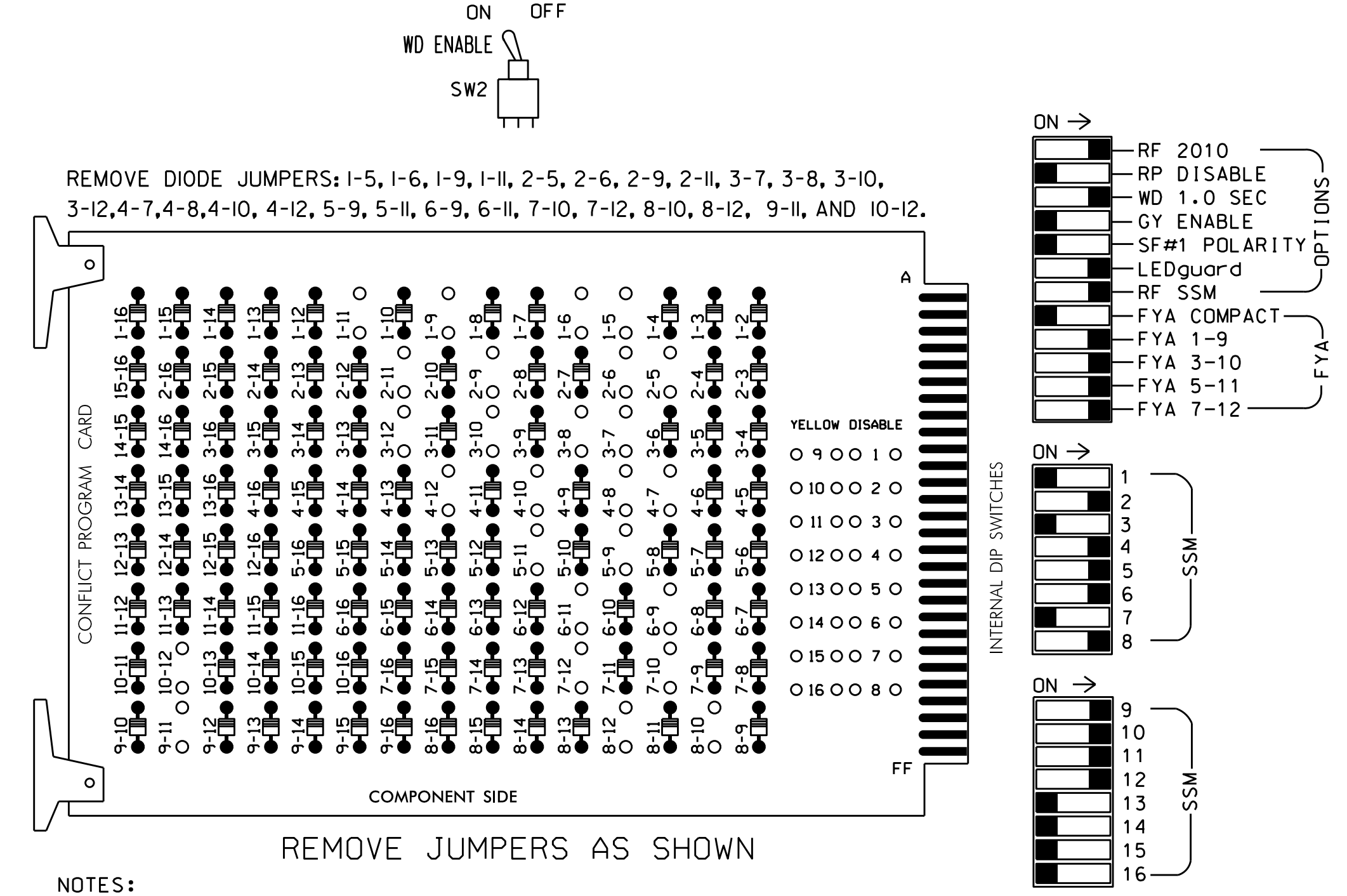

REMOVE DIODE JUMPERS: 1-5, 1-6, 1-9, 1-11, 2-5, 2-6, 2-9, 2-11, 3-7, 3-8, 3-10, 3-12, 4-7, 4-8, 4-10, 4-12, 5-9, 5-11, 6-9, 6-11, 7-10, 7-12, 8-10, 8-12, 9-11, AND 10-12.

REMOVE JUMPERS AS SHOWN

- NOTES:
- Card is provided with all diode jumpers in place. Removal of any jumper allows its channels to run concurrently.
 - Make sure jumpers SEL2-SEL5 are present on the monitor board.

NOTES

- To prevent "flash-conflict" problems, insert red flash program blocks for all unused vehicle load switches in the output file. The installer shall verify that signal heads flash in accordance with the Signal Plans.
- Ensure that Red Enable is active at all times during normal operation. To prevent Red Failures on unused monitor channels, tie unused red monitor inputs 1,3, 7,13,14,15 & 16 to load switch AC+ per the cabinet manufacturer's instructions.
- Program phases 4 and 8 for Dual Entry.
- Enable Simultaneous Gap-Out for all phases.
- Program phases 2 and 6 for Variable Initial and Gap Reduction.
- Program phases 2 and 6 for Start Up In Green.
- Program phases 2 and 6 for Yellow Flash, and overlaps 1 and 2 as Wag Overlaps.
- The cabinet and controller are part of the NC 51 (Pineville) System.

SIGNAL HEAD HOOK-UP CHART

LOAD SWITCH NO.	S1	S2	S2P	S3	S4	S4P	S5	S6	S6P	S7	S8	S8P	S9	S10	S11	S12	S13	S14	
PHASE	1	2	2 PED	3	4	4 PED	5	6	6 PED	7	8	8 PED	OLA	OLB	SPARE	OLC	OLD	SPARE	
SIGNAL HEAD NO.	11*	21,22	NU	31*	41,42	NU	42	51*	61,62	NU	71*	81,82	NU	11*	31*	NU	51*	71*	NU
RED		128			101		*		134			107							
YELLOW	*	129		*	102				135	*		108							
GREEN		130			103				136			109							
RED ARROW														A121	A124		A114	A101	
YELLOW ARROW							132							A122	A125		A115	A102	
FLASHING YELLOW ARROW														A123	A126		A116	A103	
GREEN ARROW	127				118		133	133		124									

NU = Not Used
 * Denotes install load resistor. See load resistor installation detail this sheet.
 * See pictorial of head wiring in detail below.

EQUIPMENT INFORMATION

CONTROLLER.....2070L
 CABINET.....332 /W/ AUX
 SOFTWARE.....ECONOLITE OASIS
 CABINET MOUNT.....BASE
 OUTPUT FILE POSITIONS...18 WITH AUX. OUTPUT FILE
 LOAD SWITCHES USED.....S1,S2,S3,S4,S5,S6,S7,S8,S9,S10,
 S12,S13
 PHASES USED.....1,2,3,4,5,6,7,8
 OVERLAP "A".....1+2
 OVERLAP "B".....3+4
 OVERLAP "C".....5+6
 OVERLAP "D".....7+8

4 SECTION FYA PPLT SIGNAL WIRING DETAIL

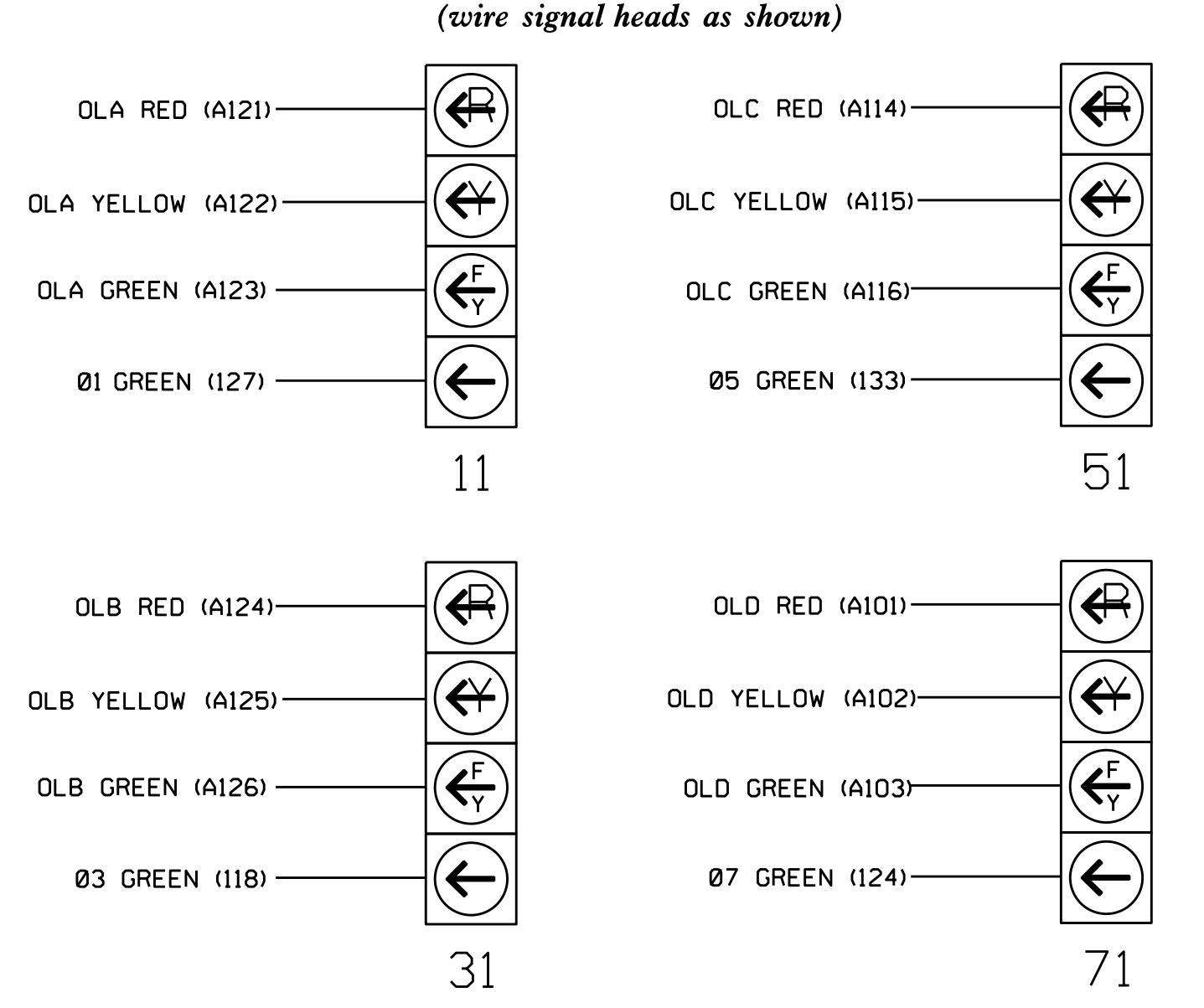

NOTE
 1. The sequence display for these signals require special logic programming. See sheet 2 of 2 for programming instructions.

INPUT FILE POSITION LAYOUT

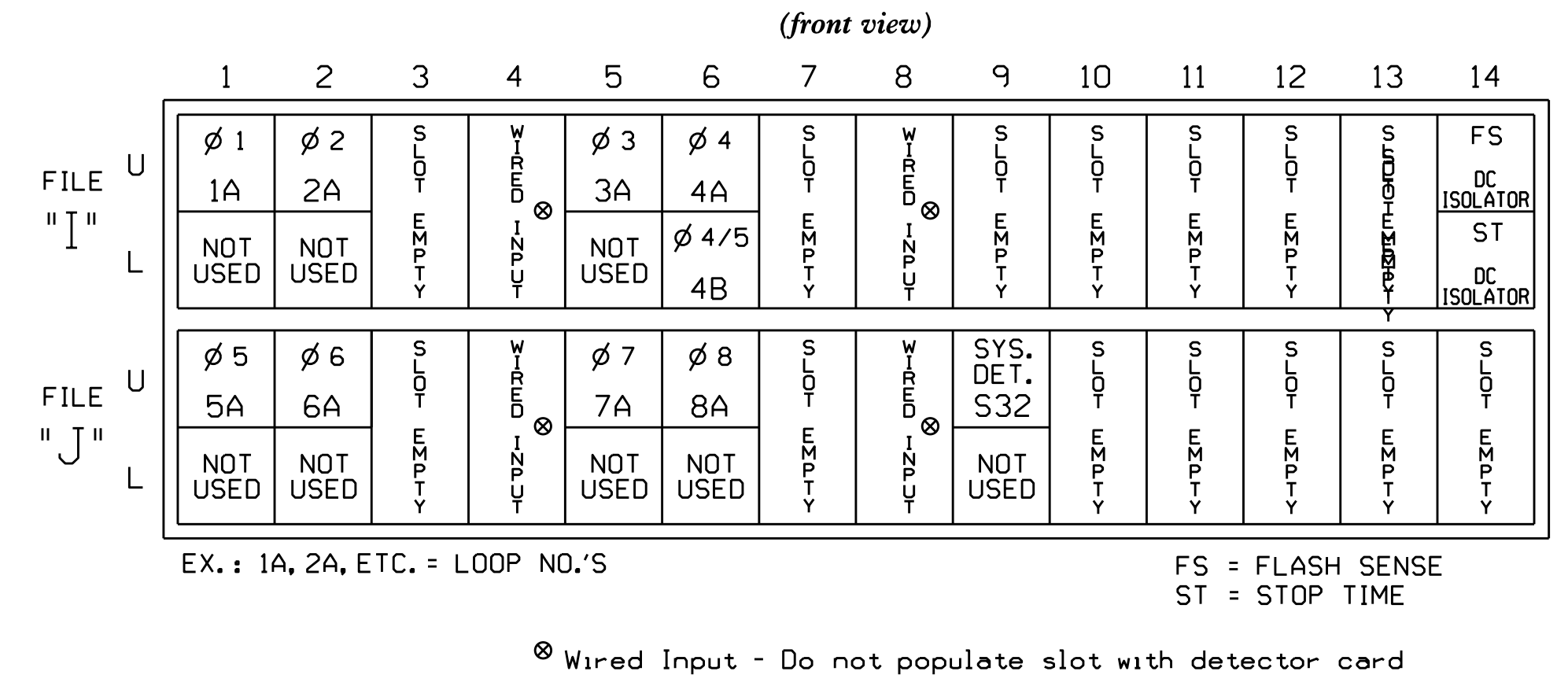

INPUT FILE CONNECTION & PROGRAMMING CHART

LOOP NO.	LOOP TERMINAL	INPUT FILE POS.	PIN NO.	INPUT ASSIGNMENT NO.	DETECTOR NO.	NEMA PHASE	CALL	EXTEND	FULL TIME DELAY	STRETCH TIME	DELAY TIME
1A ¹	TB2-1,2	I1U	56	18	1	1	Y	Y			15
	-	J4U	48	10	26	6	Y	Y	Y		3
2A	TB2-5,6	I2U	39	1	2	2	Y	Y			
	TB4-5,6	I5U	58	20	3	3	Y	Y			15
3A ²	-	J8U	50	12	28	8	Y	Y			
	TB4-9,10	I6U	41	3	4	4	Y	Y			
4A	TB4-9,10	I6U	41	3	4	4	Y	Y			
4B	TB4-11,12	I6L	45	7	14	4/5	Y	Y			10
5A ³	TB3-1,2	J1U	55	17	5	5	Y	Y			15
	-	I4U	47	9	22	2	Y	Y	Y		3
6A	TB3-5,6	J2U	40	2	6	6	Y	Y			
7A ⁴	TB5-5,6	J5U	57	19	7	7	Y	Y			15
	-	I8U	49	11	24	4	Y	Y			
8A	TB5-9,10	J6U	42	4	8	8	Y	Y			
*S32	TB7-9,10	J9U	59	21	15	SYS					

- Add jumper from I1-W to J4-W, on rear of input file.
 - Add jumper from I5-W to J8-W, on rear of input file.
 - Add jumper from J1-W to I4-W, on rear of input file.
 - Add jumper from J5-W to I8-W, on rear of input file.
- * System detector only. Remove the vehicle phase assigned to this detector in the default programming.

INPUT FILE POSITION LEGEND: J2L

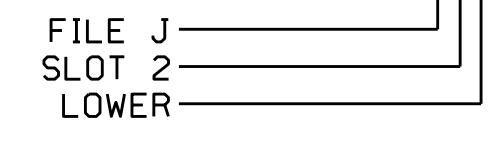

LOAD RESISTOR INSTALLATION DETAIL

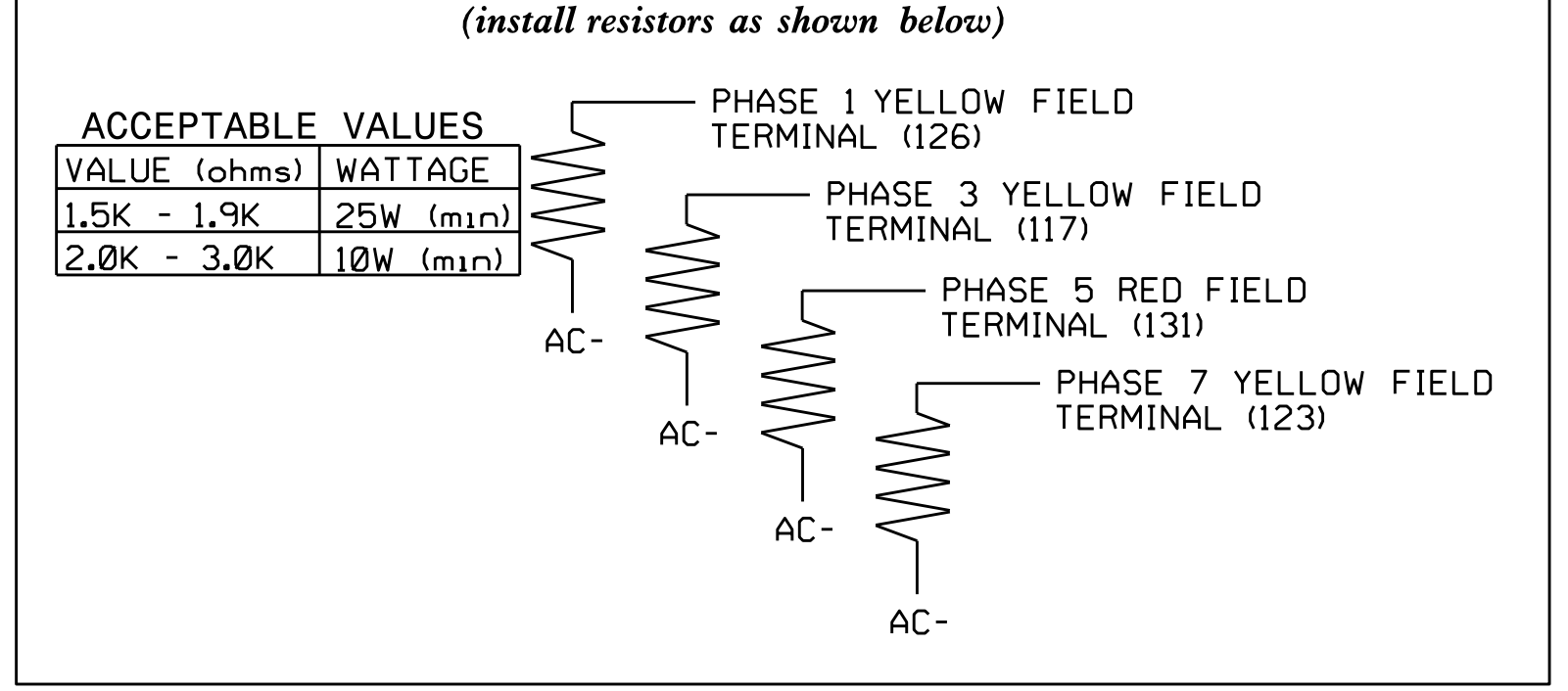

THIS ELECTRICAL DETAIL IS FOR THE SIGNAL DESIGN: 10-1338T
 DESIGNED: March 2015
 SEALED: 4/16/2015
 REVISED: N/A

Electrical Detail - Temporary - Sheet 1 of 2

Electrical and Programming Details For:	SR 4982 (Lancaster Highway) at SR 4931 (Carolina Place Parkway)	SEAL
Prepared In the Offices of:	Division 10 Mecklenburg County Pineville	
	PLAN DATE: April 2015 REVIEWED BY: T. Joyce PREPARED BY: C. Strickland REVIEWED BY:	
750 N. Greenfield Pkwy, Garner, NC 27529	REVISIONS: _____ INIT. DATE _____ _____	Signed by: <i>George C. Brown</i> 4/22/2015 F12001ED08B434 DATE SIG. INVENTORY NO. 10-1338T