

TYPICAL SECTION @ BENT DIAPHRAGM

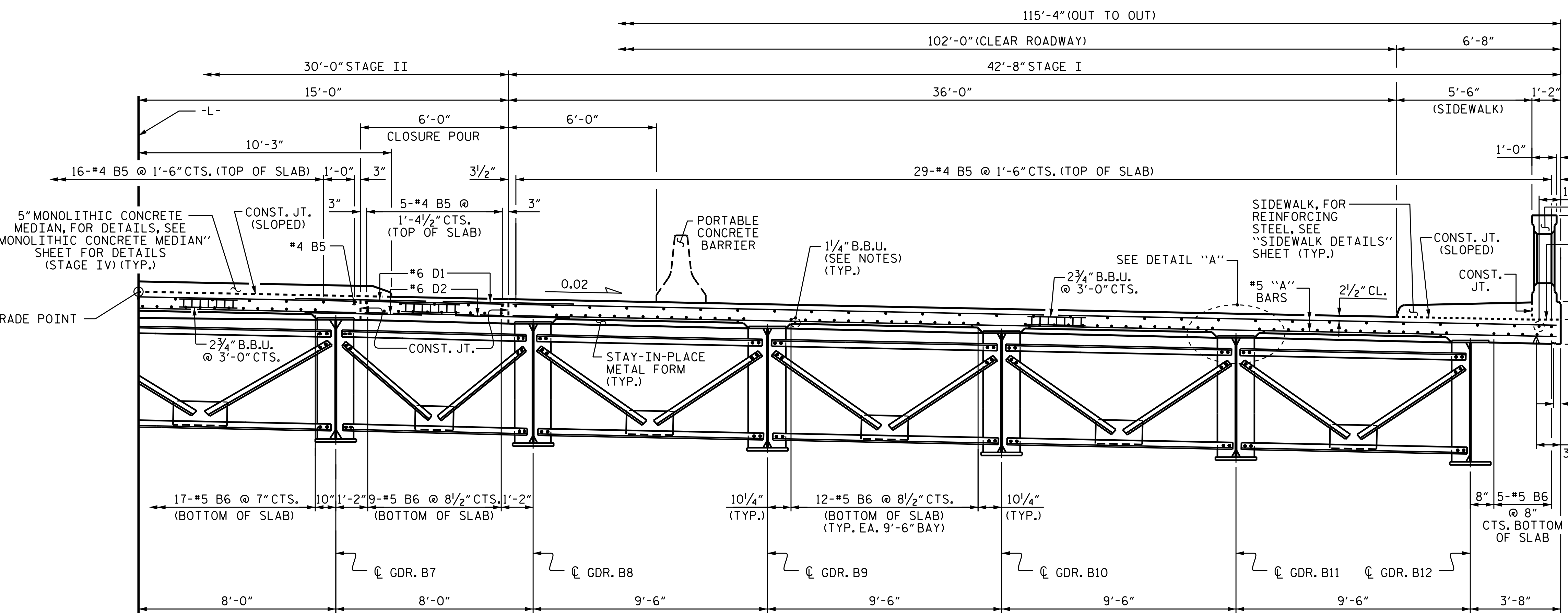

TYPICAL SECTION @ INTERMEDIATE DIAPHRAGM

NOTES

PROVIDE 1/4" HIGH BEAM BOLSTERS UPPER AT 4'-0" CTS. ATOP THE METAL STAY-IN-PLACE FORMS TO SUPPORT THE BOTTOM MAT OF 'A' BARS. WHEN USING REMOVABLE FORMS, PROVIDE CONTINUOUS HIGH CHAIRS FOR METAL DECK (C.H.C.M.) @ 4'-0" CTS. WITH A HEIGHT TO SUPPORT THE BOTTOM MAT OF 'A' BARS A CLEAR DISTANCE OF 2 1/2" ABOVE THE TOP OF THE REMOVABLE FORM.

BARRIER RAIL IN EACH SPAN SHALL NOT BE CAST UNTIL ALL SLAB CONCRETE IN THAT SPAN HAS BEEN CAST AND HAS REACHED A MINIMUM COMPRESSIVE STRENGTH OF 3,000 PSI.

DOWELS SHALL BE PLACED IN THE SAME HORIZONTAL PLANE AS THE TOP SLAB REINFORCING STEEL.

METAL STAY-IN-PLACE FORMS SHALL NOT BE WELDED TO BEAM OR GIRDER FLANGES IN THE ZONES REQUIRING CHARPY V-NOTCH TEST. SEE STRUCTURAL STEEL DETAIL SHEETS.

PREVIOUSLY CAST CONCRETE IN A SPAN SHALL HAVE ATTAINED A MINIMUM COMPRESSIVE STRENGTH OF 3,000 PSI BEFORE ADDITIONAL CONCRETE IS CAST IN THE SPAN.

SEE TRAFFIC CONTROL PLANS FOR LOCATION AND PAY LIMITS OF THE ANCHORED PORTABLE CONCRETE BARRIER.

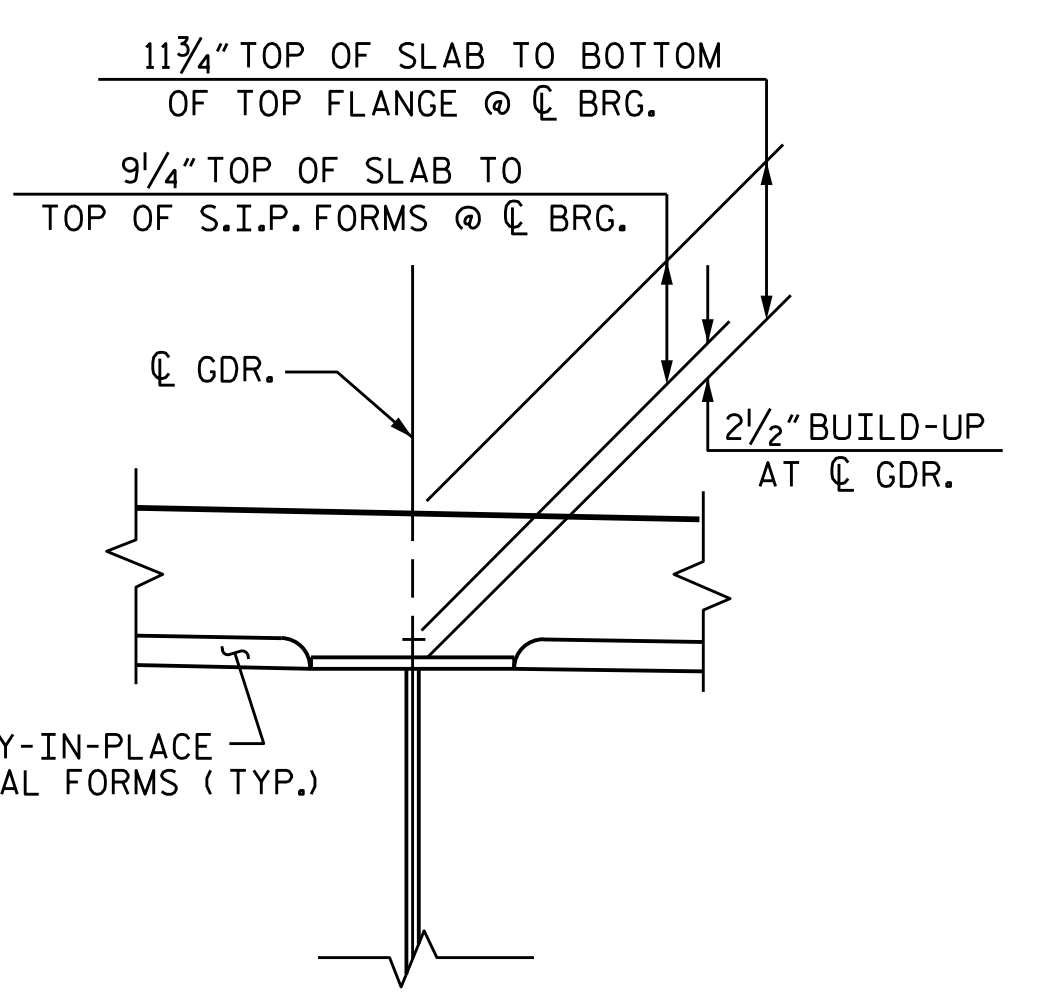

DETAIL "A"

CLASSIC CONCRETE BRIDGE RAIL, FOR REINFORCING STEEL AND DETAILS, SEE "CLASSIC CONCRETE BRIDGE RAIL WITH SIDEWALK" SHEETS. (TYP.)

PROJECT NO. B-5136
CABARRUS COUNTY
 STATION: 21+74.92 -L-

SHEET 3 OF 5

STATE OF NORTH CAROLINA
 DEPARTMENT OF TRANSPORTATION
 RALEIGH
 SUPERSTRUCTURE
 TYPICAL SECTION
 STAGE I & HALF
 STAGE II & IV
 SPAN B

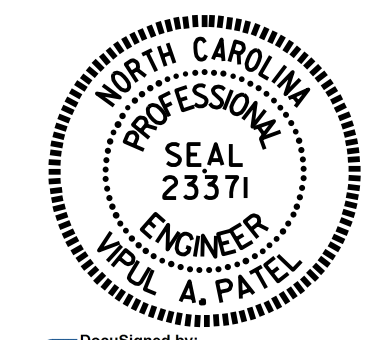

DRAWN BY : T. H. CARROLL DATE : 7/15/14
 CHECKED BY : K. D. LAYNE DATE : 11/25/14
 DESIGN ENGINEER OF RECORD : V. A. PATEL DATE : 1/5/15

18-FEB-2015 14:02
 R:\Structures\Plans\B5136.SD.TS.01.dgn
 thcarroll

REVISIONS				SHEET NO.	
NO.	BY:	DATE:	NO.	BY:	DATE:
1			3		
2			4		
					TOTAL SHEETS
					75