

TYPICAL SECTION @ END BENT AND BENT

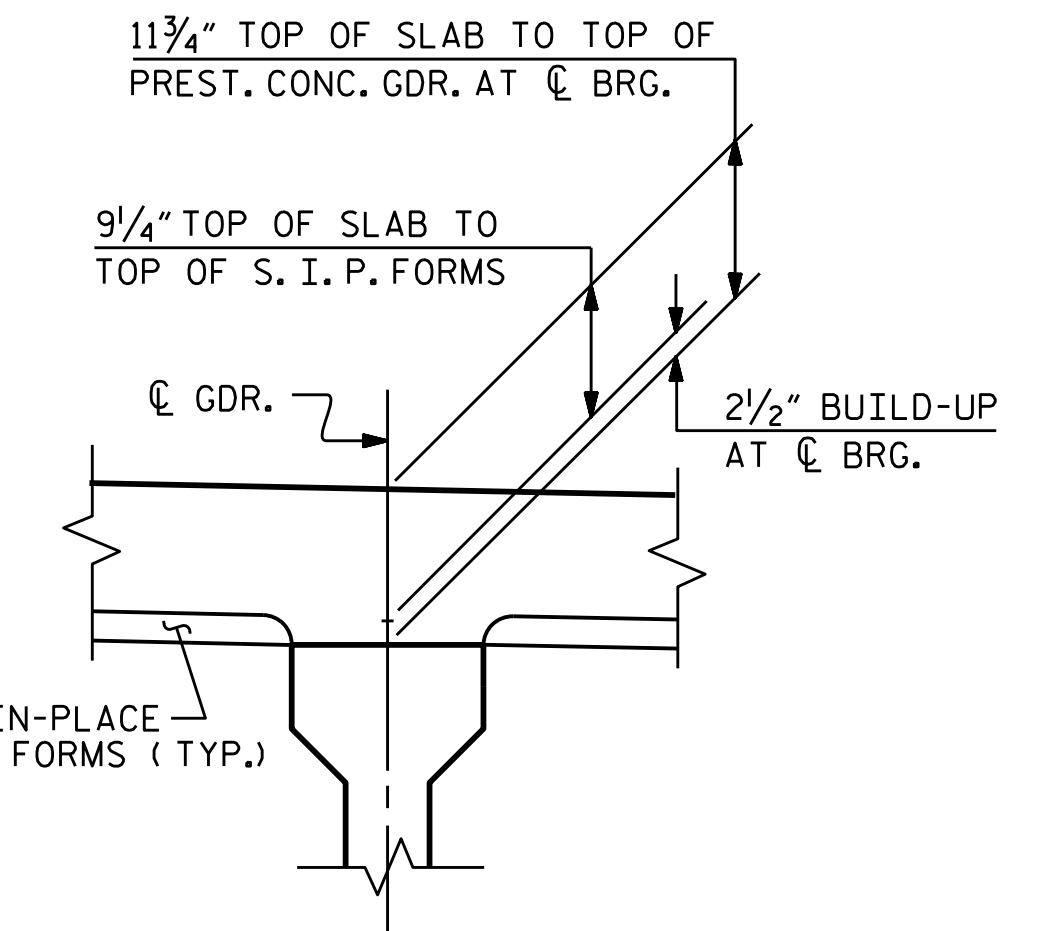

DETAIL "A"

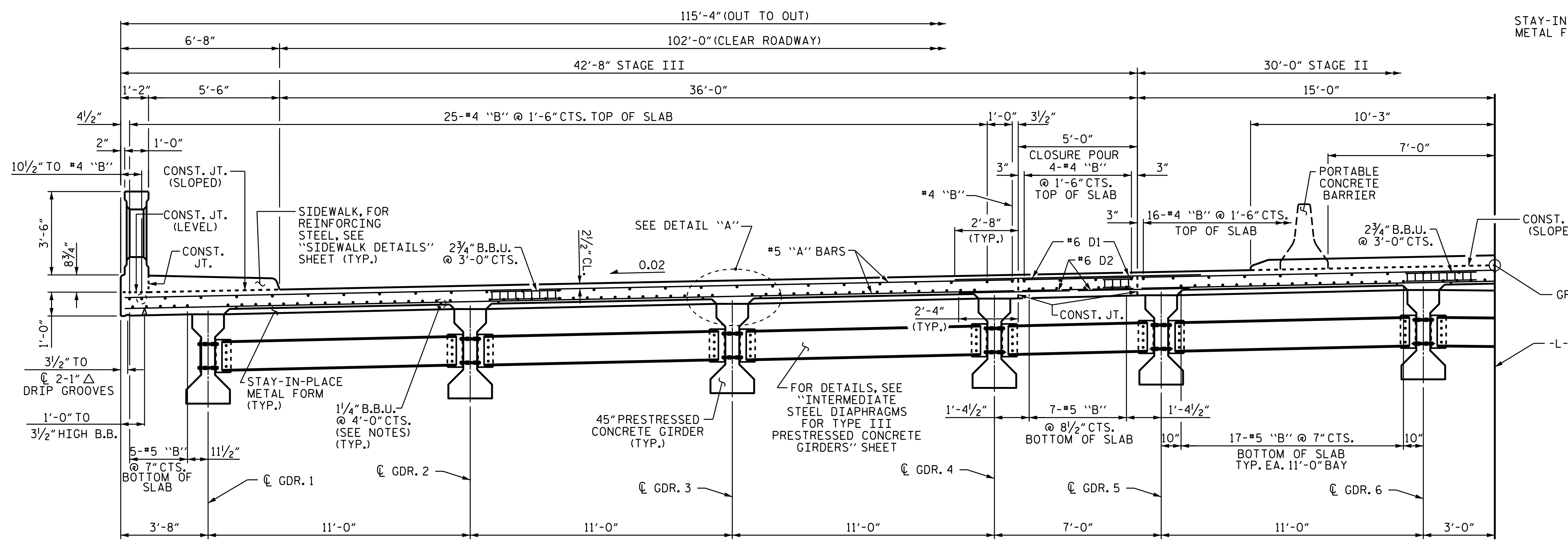

TYPICAL SECTION @ INTERMEDIATE DIAPHRAGM

PROJECT NO. B-5136
CABARRUS COUNTY
 STATION: 21+74.92 -L-
 SHEET 2 OF 5

STATE OF NORTH CAROLINA DEPARTMENT OF TRANSPORTATION RALEIGH					
SUPERSTRUCTURE TYPICAL SECTION STAGE III & HALF STAGE II & IV SPANS A & C					
REVISIONS					SHEET NO.
NO.	BY:	DATE:	NO.	BY:	DATE:
1			3		
2			4		
					TOTAL SHEETS 75



DRAWN BY : P.S. ADKINS DATE : 7/10/14
 CHECKED BY : K.D. LAYNE DATE : 11/14/14
 DESIGN ENGINEER OF RECORD : V. A. PATEL DATE : 1/5/15