

MICROWAVE DETECTOR WIRING DETAIL

(wire as shown)

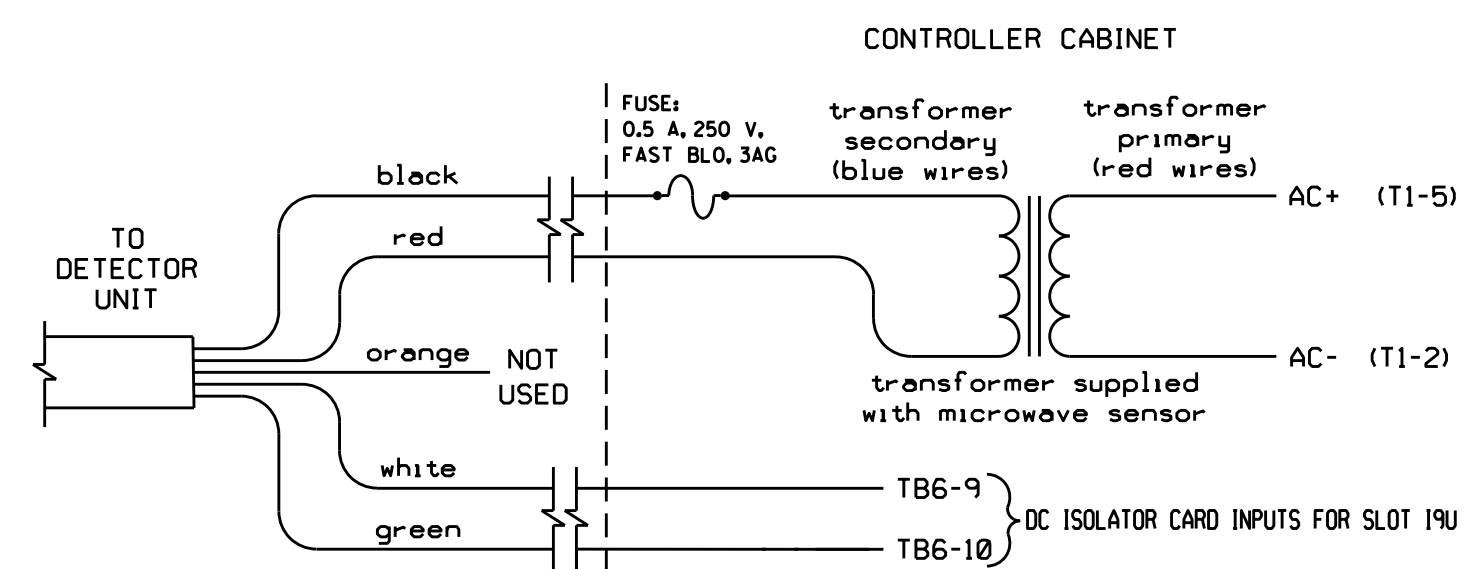

TC26B WIRE LIST

COLOR	FUNCTION
black	12V to 24V AC/DC (no polarity)
red	12V to 24V AC/DC (no polarity)
orange	Output Relay Normally Open
white	Output Relay Normally Closed
green	Output Relay Common

NOTES:

1. Sensor is a microwave motion detector mounted on poles as indicated on the Signal Design Plans.
2. Microwave wiring shown above will cause a permanent call unless the Input Assignment Programming and Logical I/O Processor Programming details are entered as shown on this sheet and sheet 2. These programming details will cause a call to be placed upon opening the Normally Closed contact.
3. DC Isolator's LED will be ON when no call is present and will be OFF when a call is present.
4. Important: For proper operation of the microwave detector, remove surge protection from TB6-9, TB6-10, TB6-11, and TB6-12 and insert 242 DC Isolator in slot 19.

INPUT ASSIGNMENT PROGRAMMING DETAIL FOR MICROWAVE DETECTOR INPUT (DETECTOR 11)

(program controller as shown below)

FROM MAIN MENU PRESS '5' (INPUTS), THEN '+' UNTIL INPUT 22 (PIN 60) IS REACHED. MODIFY DEFAULT CONDITIONS AS INDICATED BY ARROWS.

```

PAGE: 1 C1 PIN:60 NOT ENABLED
INPUT ASSIGNMENT #.....22
DEBOUNCE TIME (0-25.5 SEC).....0.5
DELAY TIME (0-25.5 SEC).....0.0
HOLD-OVER TIME (0-25.5 SEC).....0.0
ASSIGNMENT SELECTION:
NOT ENABLED (Y/N).....Y
VEHICLE DETECTOR (1-64).....
PEDESTRIAN DETECTOR (1-16).....
ALTERNATE PED DETECTOR (1-16).....
PREEMPT (1-10).....
INVERTED PREEMPT (1-10).....
STOP TIME (Y/N).....
FLASH SENSE (Y/N).....
DOOR OPEN (Y/N).....
MANUAL CONTROL ENABLE (Y/N).....
MANUAL CONTROL ADVANCE (Y/N).....
SPECIAL FUNCTION ALARM (1-8).....
TOD HOUR SYNCHRONIZATION (0-23).....
FORCE OFF RING (1-4).....
HOLD PHASES (1-16).....
PLAN (65=FLSH,66=FREE)... OFFSET#...
CHANGE PHASE SEQUENCE PAGE (1-12)...
CHANGE PHASE TIMING PAGE (1-4).....
CHANGE PHASE CONTROL PAGE (1-4).....
CHANGE OVERLAP CONTROL PAGE (1-4).....
CHANGE INPUT PAGE (1-4).....
CHANGE OUTPUT PAGE (1-4).....
OVERRIDE PHASE CONTROL FUNCTION (Y)...
    
```

ENTER 'YES' for Not Enabled

```

PAGE: 1 C1 PIN:0 VEHICLE DETECTOR
INPUT ASSIGNMENT #.....63
DEBOUNCE TIME (0-25.5 SEC).....0.5
DELAY TIME (0-25.5 SEC).....0.0
HOLD-OVER TIME (0-25.5 SEC).....0.0
ASSIGNMENT SELECTION:
NOT ENABLED (Y/N).....
VEHICLE DETECTOR (1-64).....11
PEDESTRIAN DETECTOR (1-16).....
ALTERNATE PED DETECTOR (1-16).....
PREEMPT (1-10).....
INVERTED PREEMPT (1-10).....
STOP TIME (Y/N).....
FLASH SENSE (Y/N).....
DOOR OPEN (Y/N).....
MANUAL CONTROL ENABLE (Y/N).....
MANUAL CONTROL ADVANCE (Y/N).....
SPECIAL FUNCTION ALARM (1-8).....
TOD HOUR SYNCHRONIZATION (0-23).....
FORCE OFF RING (1-4).....
HOLD PHASES (1-16).....
PLAN (65=FLSH,66=FREE)...65 OFFSET#...
CHANGE PHASE SEQUENCE PAGE (1-12)...
CHANGE PHASE TIMING PAGE (1-4).....
CHANGE PHASE CONTROL PAGE (1-4).....
CHANGE OVERLAP CONTROL PAGE (1-4).....
CHANGE INPUT PAGE (1-4).....
CHANGE OUTPUT PAGE (1-4).....
OVERRIDE PHASE CONTROL FUNCTION (Y)...
    
```

ENTER '11' for Vehicle Detector

THIS ELECTRICAL DETAIL IS FOR THE SIGNAL DESIGN: 10-0417 T4
 DESIGNED: November 2014
 SEALED: 12-15-14
 REVISED: N/A

PRESS '-' until Input Assignment #63 is reached

PROGRAMMING COMPLETE

NOTE:

This remapping removes the default detector from the microwave's physical input and reassigns it to unused INPUT 63. The Logical I/O Processor Programming Detail on sheets will invert the disabled input and control INPUT 63 and the reassigned detector.

16-JAN-2014 11:25
 S:\ITC\SSM\T5-S1\sigma\work\gpc\sig_Mar\ Peterson\100417_sml.ele_xxx.dgn
 Peterson

Electrical Detail - Sheet 3 of 3

	DETAILS FOR: US 29-601 / NC 73 (Concord Parkway North) at NC 73 (Davidson Drive) / Davidson Drive		SEAL
	Division 10 Cabarrus County PLAN DATE: November 2014 PREPARED BY: James Peterson	REVIEWED BY: JTR REVIEWED BY:	
REVISIONS		INIT.	DATE
750 N. Greenfield Pkwy, Garner, NC 27529		SIG. INVENTORY NO. 10-0417 T4	