

MICROWAVE DETECTOR WIRING DETAIL

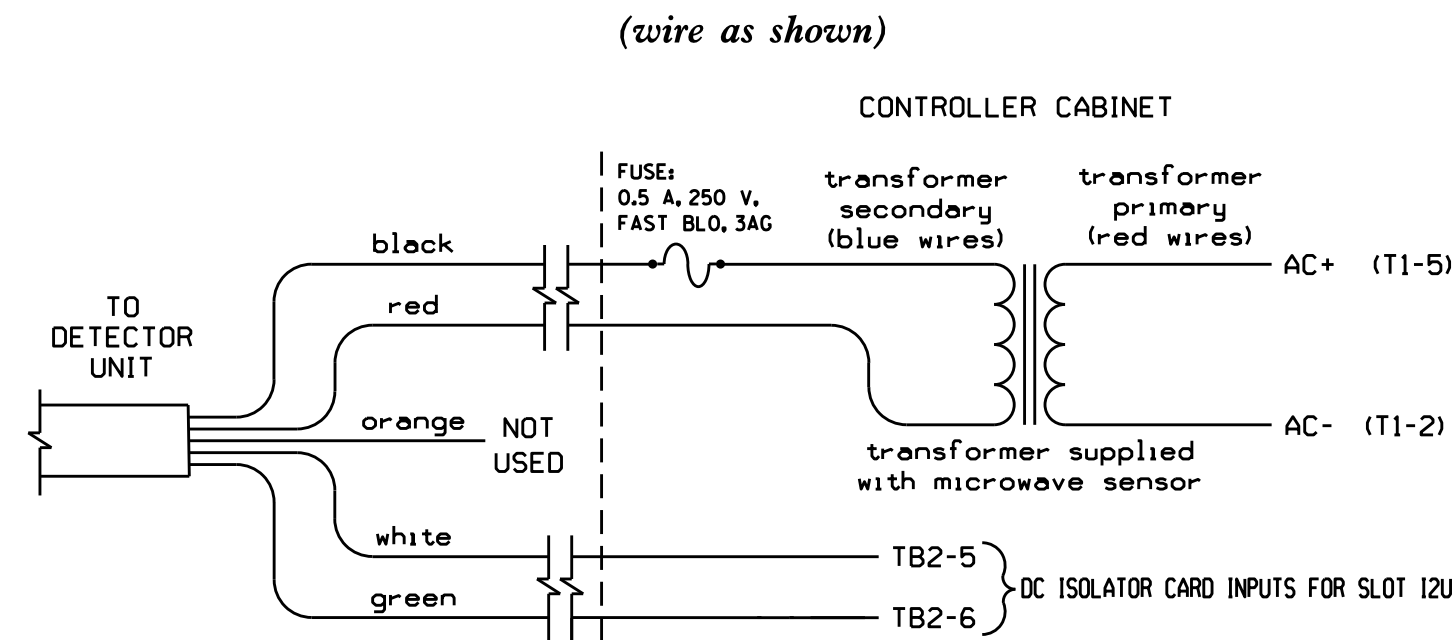

TC26B WIRE LIST

COLOR	FUNCTION
black	12V to 24V AC/DC (no polarity)
red	12V to 24V AC/DC (no polarity)
orange	Output Relay Normally Open
white	Output Relay Normally Closed
green	Output Relay Common

NOTES:

- Sensor is a microwave motion detector mounted on poles as indicated on the Signal Design Plans.
- Microwave wiring shown above will cause a permanent call unless the Input Assignment Programming and Logical I/O Processor Programming details are entered as shown on this sheet. These programming details will cause a call to be placed upon opening the Normally Closed contact.
- DC Isolator's LED will be ON when no call is present and will be OFF when a call is present.
- Important: For proper operation of the microwave detector, remove surge protection from TB2-5, TB2-6, TB2-7, and TB2-8 and insert 242 DC Isolator in slot 12.

LOGICAL I/O PROCESSOR PROGRAMMING DETAIL TO INVERT INPUT FROM MICROWAVE DETECTOR

(program controller as shown below)

- From Main Menu press '6' (Outputs), Then '3' (Logical I/O Processor).
- From Main Menu press '2' (Phase Control), Then '1' (Phase Control Functions). Scroll to the bottom of the menu and enable ACT LOGIC Commands 1, 2, 3 and 4.

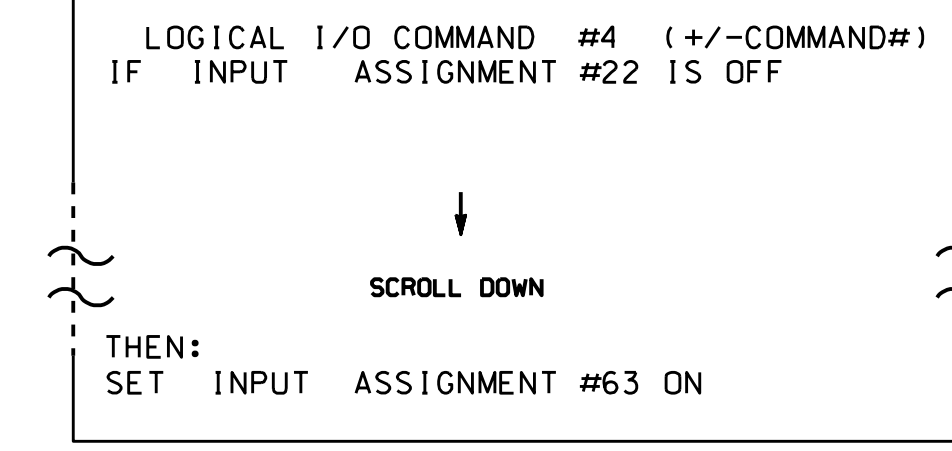
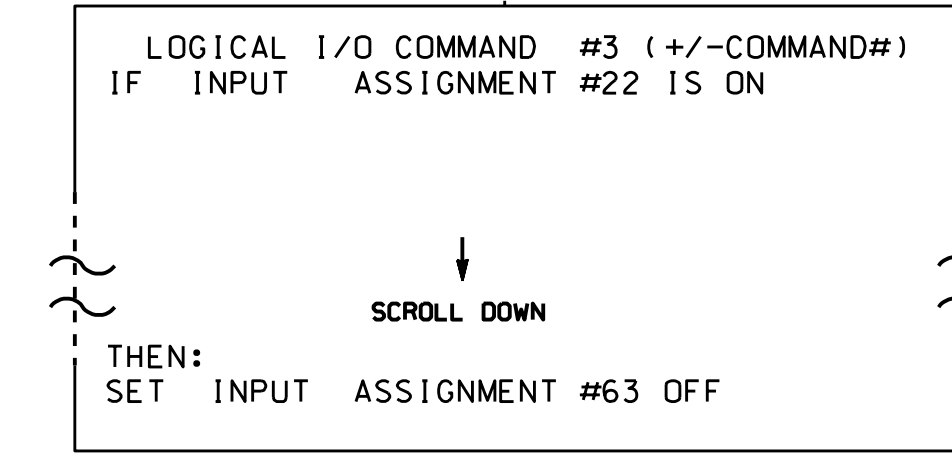
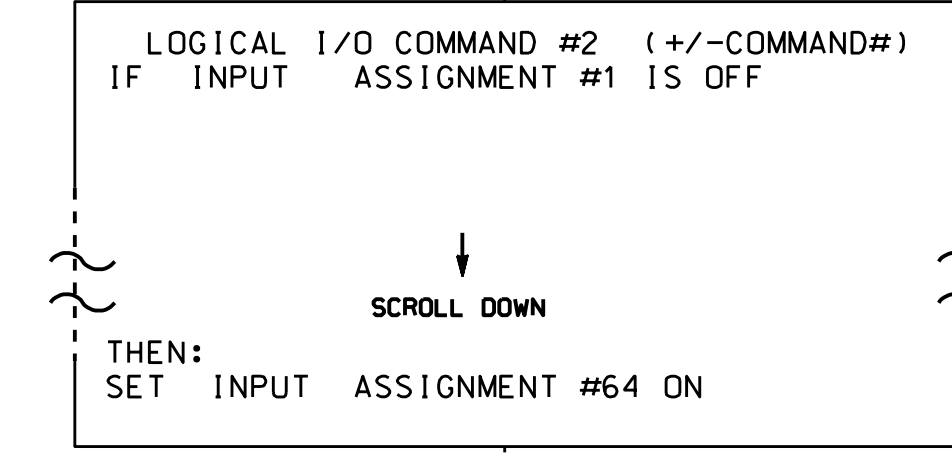
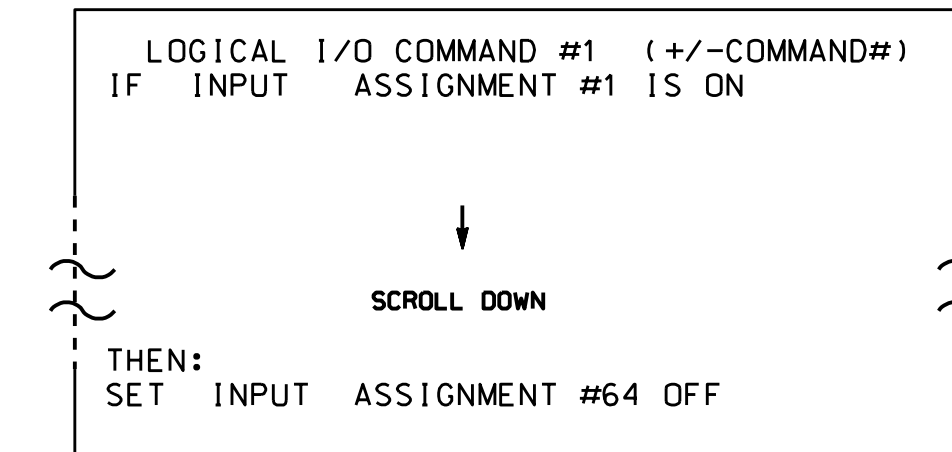

LOGIC I/O PROCESSOR PROGRAMMING COMPLETE

REFERENCE SCHEDULE

INPUT 1	= Microwave Detector Physical Input (Not Enabled)
INPUT 64	= Dummy Microwave Detector Input (Detector 2)
INPUT 22	= Microwave Detector Physical Input (Not Enabled)
INPUT 63	= Dummy Microwave Detector Input (Detector 11)

INPUT ASSIGNMENT PROGRAMMING DETAIL FOR MICROWAVE DETECTOR INPUT (2)

(program controller as shown below)

FROM MAIN MENU PRESS '5' (INPUTS), THEN '+' UNTIL INPUT 1 (PIN 39) IS REACHED. MODIFY DEFAULT CONDITIONS AS INDICATED BY ARROWS.

```

PAGE: 1 C1 PIN:39 NOT ENABLED
INPUT ASSIGNMENT #.....1
DEBOUNCE TIME (0-25.5 SEC).....0.5
DELAY TIME (0-25.5 SEC).....0.0
HOLD-OVER TIME (0-25.5 SEC).....0.0
ASSIGNMENT SELECTION:
NOT ENABLED (Y/N).....Y
VEHICLE DETECTOR (1-64).....
PEDESTRIAN DETECTOR (1-16).....
ALTERNATE PED DETECTOR (1-16).....
PREEMPT (1-10).....
INVERTED PREEMPT (1-10).....
STOP TIME (Y/N).....
FLASH SENSE (Y/N).....
DOOR OPEN (Y/N).....
MANUAL CONTROL ENABLE (Y/N).....
MANUAL CONTROL ADVANCE (Y/N).....
SPECIAL FUNCTION ALARM (1-8).....
TOD HOUR SYNCHRONIZATION (0-23).....
FORCE OFF RING (1-4).....
HOLD PHASES (1-16).....
PLAN (65=FLSH,66=FREE)... OFFSET#...
CHANGE PHASE SEQUENCE PAGE (1-12)...
CHANGE PHASE TIMING PAGE (1-4).....
CHANGE PHASE CONTROL PAGE (1-4).....
CHANGE OVERLAP CONTROL PAGE (1-4)...
CHANGE INPUT PAGE (1-4).....
CHANGE OUTPUT PAGE (1-4).....
OVERRIDE PHASE CONTROL FUNCTION (Y)...
  
```

ENTER 'YES' for Not Enabled

```

PAGE: 1 C1 PIN:0 VEHICLE DETECTOR
INPUT ASSIGNMENT #.....64
DEBOUNCE TIME (0-25.5 SEC).....0.5
DELAY TIME (0-25.5 SEC).....0.0
HOLD-OVER TIME (0-25.5 SEC).....0.0
ASSIGNMENT SELECTION:
NOT ENABLED (Y/N).....
VEHICLE DETECTOR (1-64).....2
PEDESTRIAN DETECTOR (1-16).....
ALTERNATE PED DETECTOR (1-16).....
PREEMPT (1-10).....
INVERTED PREEMPT (1-10).....
STOP TIME (Y/N).....
FLASH SENSE (Y/N).....
DOOR OPEN (Y/N).....
MANUAL CONTROL ENABLE (Y/N).....
MANUAL CONTROL ADVANCE (Y/N).....
SPECIAL FUNCTION ALARM (1-8).....
TOD HOUR SYNCHRONIZATION (0-23).....
FORCE OFF RING (1-4).....
HOLD PHASES (1-16).....
PLAN (65=FLSH,66=FREE)...65 OFFSET#...
CHANGE PHASE SEQUENCE PAGE (1-12)...
CHANGE PHASE TIMING PAGE (1-4).....
CHANGE PHASE CONTROL PAGE (1-4).....
CHANGE OVERLAP CONTROL PAGE (1-4)...
CHANGE INPUT PAGE (1-4).....
CHANGE OUTPUT PAGE (1-4).....
OVERRIDE PHASE CONTROL FUNCTION (Y)...
  
```

ENTER '2' for Vehicle Detector

PROGRAMMING COMPLETE

PRESS '-' until Input Assignment #64 is reached

NOTE:

This remapping removes the default detector from the microwave's physical input and reassigns it to unused INPUT 64. The Logical I/O Processor Programming Detail on this sheet will invert the disabled input and control INPUT 64 and the reassigned detector.

THIS ELECTRICAL DETAIL IS FOR THE SIGNAL DESIGN: 10-0417 T2
 DESIGNED: November 2014
 SEALED: 12-15-14
 REVISED: N/A

Electrical Detail- Sheet 2 of 3

	US 29-601 / NC 73 (Concord Parkway North) at NC 73 (Davidson Drive) / Davidson Drive	SEAL
	Division 10 Cabarrus County PLAN DATE: November 2014 PREPARED BY: James Peterson	Concord REVIEWED BY: JTR REVISIONS INIT. DATE