

MICROWAVE DETECTOR WIRING DETAIL

(wire as shown)

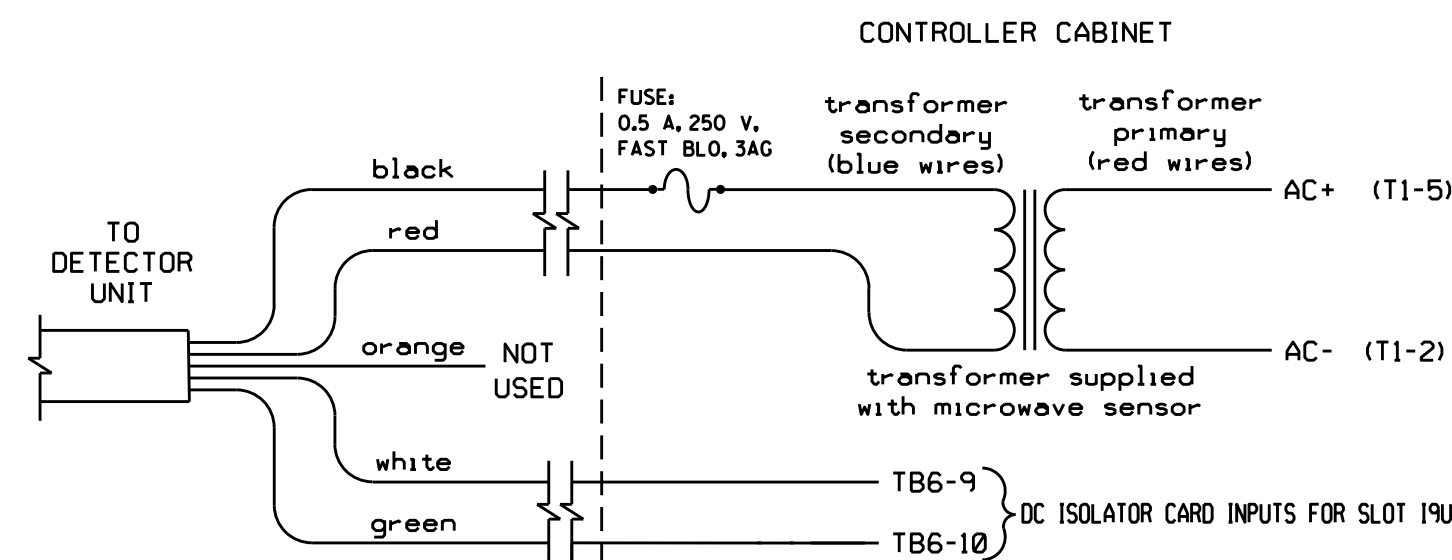

TC26B WIRE LIST

COLOR	FUNCTION
black	12V to 24V AC/DC (no polarity)
red	12V to 24V AC/DC (no polarity)
orange	Output Relay Normally Open
white	Output Relay Normally Closed
green	Output Relay Common

NOTES:

1. Sensor is a microwave motion detector mounted on poles as indicated on the Signal Design Plans.
2. Microwave wiring shown above will cause a permanent call unless the Input Assignment Programming and Logical I/O Processor Programming details are entered as shown on this sheet and sheet 2. These programming details will cause a call to be placed upon opening the Normally Closed contact.
3. DC Isolator's LED will be ON when no call is present and will be OFF when a call is present.
4. Important: For proper operation of the microwave detector, remove surge protection from TB6-9, TB6-10, TB6-11, and TB6-12 and insert 242 DC Isolator in slot 19.

INPUT ASSIGNMENT PROGRAMMING DETAIL FOR MICROWAVE DETECTOR INPUT (DETECTOR 11)

(program controller as shown below)

FROM MAIN MENU PRESS '5' (INPUTS), THEN '+' UNTIL INPUT 22 (PIN 60) IS REACHED. MODIFY DEFAULT CONDITIONS AS INDICATED BY ARROWS.

```

PAGE: 1 C1 PIN:60 NOT ENABLED
INPUT ASSIGNMENT #.....22
DEBOUNCE TIME (0-25.5 SEC).....0.5
DELAY TIME (0-25.5 SEC).....0.0
HOLD-OVER TIME (0-25.5 SEC).....0.0
ASSIGNMENT SELECTION:
NOT ENABLED (Y/N).....Y
VEHICLE DETECTOR (1-64).....-
PEDESTRIAN DETECTOR (1-16).....-
ALTERNATE PED DETECTOR (1-16).....-
PREEMPT (1-10).....-
INVERTED PREEMPT (1-10).....-
STOP TIME (Y/N).....-
FLASH SENSE (Y/N).....-
DOOR OPEN (Y/N).....-
MANUAL CONTROL ENABLE (Y/N).....-
MANUAL CONTROL ADVANCE (Y/N).....-
SPECIAL FUNCTION ALARM (1-8).....-
TOD HOUR SYNCHRONIZATION (0-23).....-
FORCE OFF RING (1-4).....-
HOLD PHASES (1-16).....-
PLAN (65=FLSH,66=FREE)... OFFSET#...
CHANGE PHASE SEQUENCE PAGE (1-12)...
CHANGE PHASE TIMING PAGE (1-4).....
CHANGE PHASE CONTROL PAGE (1-4).....
CHANGE OVERLAP CONTROL PAGE (1-4)...
CHANGE INPUT PAGE (1-4).....
CHANGE OUTPUT PAGE (1-4).....
OVERRIDE PHASE CONTROL FUNCTION (Y)...
    
```

ENTER 'YES' for Not Enabled

```

PAGE: 1 C1 PIN:0 VEHICLE DETECTOR
INPUT ASSIGNMENT #.....63
DEBOUNCE TIME (0-25.5 SEC).....0.5
DELAY TIME (0-25.5 SEC).....0.0
HOLD-OVER TIME (0-25.5 SEC).....0.0
ASSIGNMENT SELECTION:
NOT ENABLED (Y/N).....-
VEHICLE DETECTOR (1-64).....11
PEDESTRIAN DETECTOR (1-16).....-
ALTERNATE PED DETECTOR (1-16).....-
PREEMPT (1-10).....-
INVERTED PREEMPT (1-10).....-
STOP TIME (Y/N).....-
FLASH SENSE (Y/N).....-
DOOR OPEN (Y/N).....-
MANUAL CONTROL ENABLE (Y/N).....-
MANUAL CONTROL ADVANCE (Y/N).....-
SPECIAL FUNCTION ALARM (1-8).....-
TOD HOUR SYNCHRONIZATION (0-23).....-
FORCE OFF RING (1-4).....-
HOLD PHASES (1-16).....-
PLAN (65=FLSH,66=FREE)..65 OFFSET#...
CHANGE PHASE SEQUENCE PAGE (1-12)...
CHANGE PHASE TIMING PAGE (1-4).....
CHANGE PHASE CONTROL PAGE (1-4).....
CHANGE OVERLAP CONTROL PAGE (1-4)...
CHANGE INPUT PAGE (1-4).....
CHANGE OUTPUT PAGE (1-4).....
OVERRIDE PHASE CONTROL FUNCTION (Y)...
    
```

ENTER '11' for Vehicle Detector

PRESS '-' until Input Assignment #63 is reached

PROGRAMMING COMPLETE

NOTE:

This remapping removes the default detector from the microwave's physical input and reassigns it to unused INPUT 63. The Logical I/O Processor Programming Detail on sheet 2 will invert the disabled input and control INPUT 63 and the reassigned detector.

THIS ELECTRICAL DETAIL IS FOR THE SIGNAL DESIGN: 10-0820 T4
DESIGNED: November 2014
SEALED: 12-15-14
REVISED: N/A

ELECTRICAL DETAIL SHEET 4 OF 4

	ELECTRICAL AND PROGRAMMING DETAILS FOR: US 29-601 / US 29-601-NC 73 (Concord Parkway North) at NC 73 (Davidson Parkway) / Florence Street	SEAL
	Division 10 Cabarrus County ds Concord PLAN DATE: December 2014 REVIEWED BY: JTR PREPARED BY: James Peterson REVIEWED BY:	DocuSigned by: John T. Rowe, Jr. 12/17/2014 DATE:
REVISIONS INIT. DATE		SIG. INVENTORY NO. 10-0820T4