

EDI MODEL 2010ECL-NC CONFLICT MONITOR PROGRAMMING DETAIL

(remove jumpers and set switches as shown)

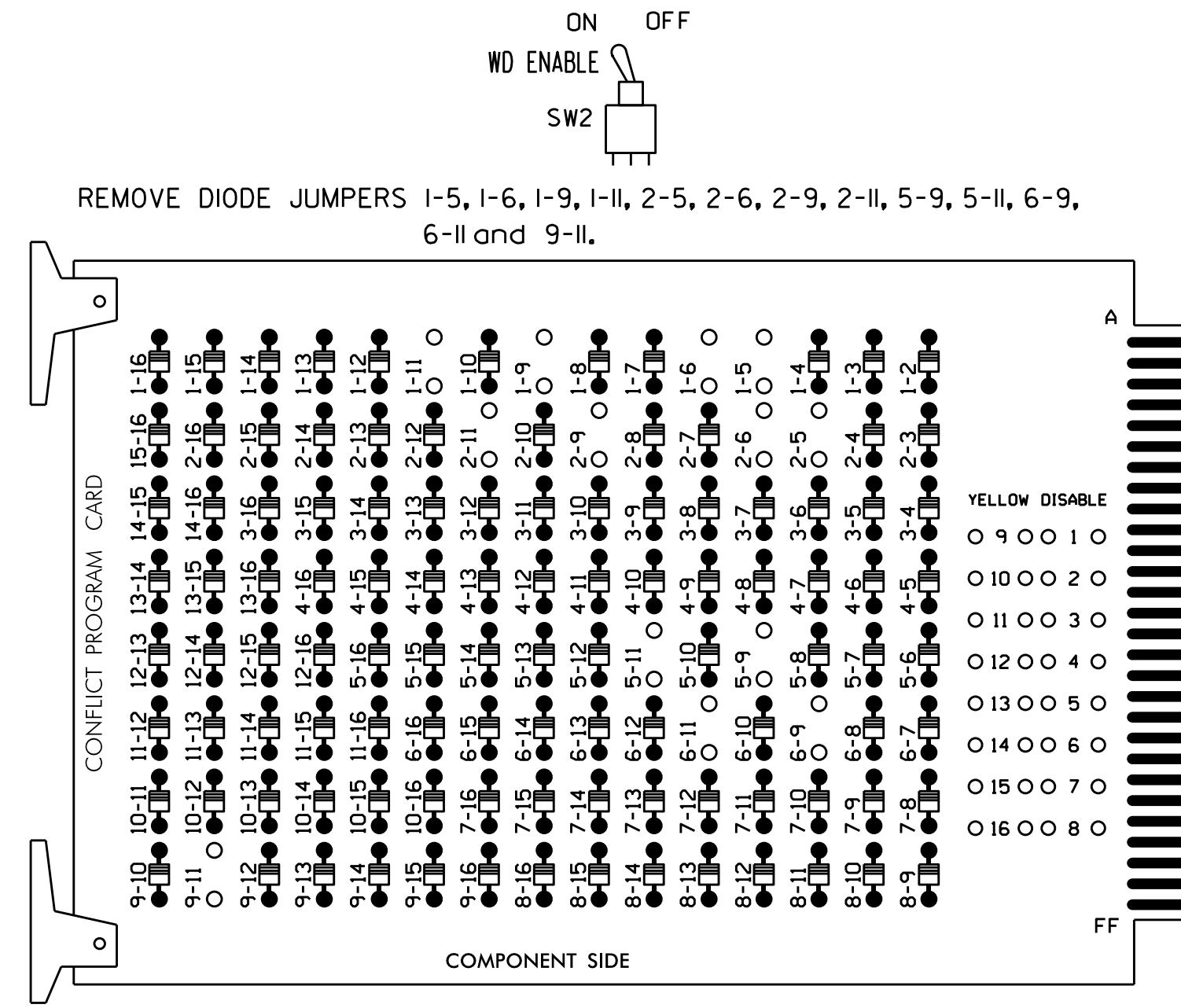

REMOVE DIODE JUMPERS 1-5, 1-6, 1-9, 1-11, 2-5, 2-6, 2-9, 2-11, 5-9, 5-11, 6-9, 6-11 and 9-11.

REMOVE JUMPERS AS SHOWN

NOTES:

- Card is provided with all diode jumpers in place. Removal of any jumper allows its channels to run concurrently.
- Make sure jumpers SEL2-SEL5 are present on the monitor board.

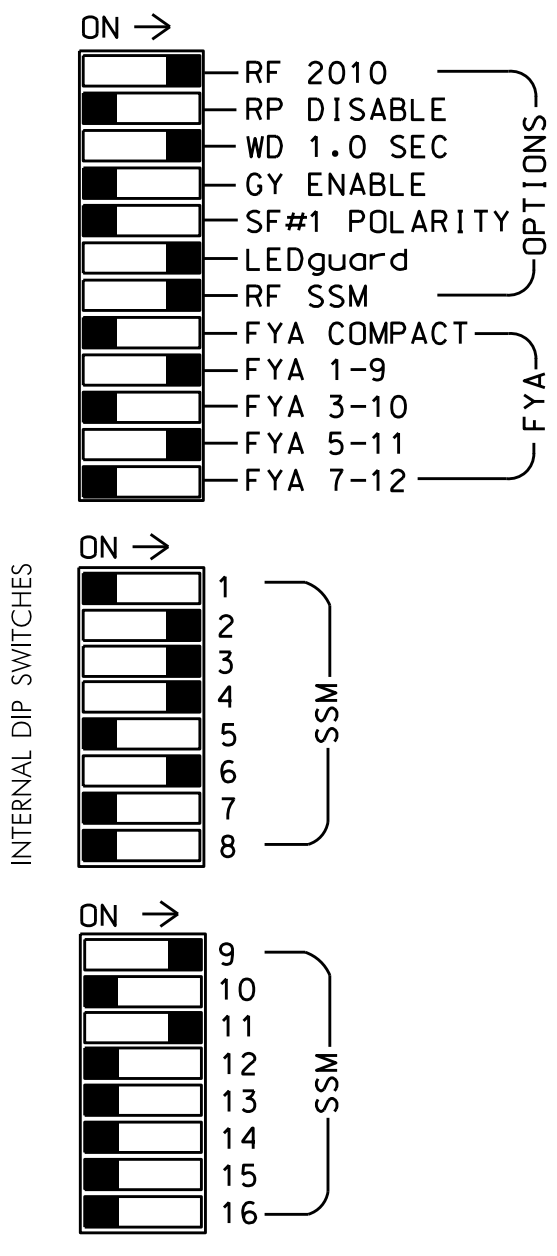

■ = DENOTES POSITION OF SWITCH

NOTES

- To prevent "flash-conflict" problems, insert red flash program blocks for all unused vehicle load switches in the output file. The installer shall verify that signal heads flash in accordance with the Signal Plans.
- Ensure that Red Enable is active at all times during normal operation. To prevent Red Failures on unused monitor channels, tie unused red monitor inputs 1,5, 7,8,10,12,13,14,15 & 16 to load switch AC+ per the cabinet manufacturer's instructions.
- Enable Simultaneous Gap-Out for all phases.
- Program phases 2 and 6 for Variable Initial and Gap Reduction.
- Program phases 2 and 6 for Start Up In Green.
- Program phases 2 and 6 for Yellow Flash, and overlap 1 as Wag Overlaps.
- The cabinet and controller are part of the Concord/Kannapolis Closed Loop System Zone 2.

SIGNAL HEAD HOOK-UP CHART

LOAD SWITCH NO.	S1	S2	S2P	S3	S4	S4P	S5	S6	S6P	S7	S8	S8P	S9	S10	S11	S12	S13	S14
PHASE	1	2	2 PED	3	4	4 PED	5	6	6 PED	7	8	8 PED	OLA	OLB	SPARE	OLC	OLD	SPARE
SIGNAL HEAD NO.	11*	21,22	NU	31 32	41,42 43,44	62	NU	51*	61,62	NU	NU	NU	11*	NU	NU	51*	NU	NU
RED		128		116 116	101			134										
YELLOW	*	129		117 117	102		*	135										
GREEN		130		118 118	103			136										
RED ARROW					101								A121				A114	
YELLOW ARROW					102	102							A122				A115	
FLASHING YELLOW ARROW													A123				A116	
GREEN ARROW	127			118	103	103	133											

NU = Not Used
 * Denotes install load resistor. See load resistor installation detail this sheet.
 * See pictorial of head wiring in detail below.

EQUIPMENT INFORMATION

CONTROLLER.....2070L
 CABINET.....332 /W/ AUX
 SOFTWARE.....ECONOLITE OASIS
 CABINET MOUNT.....BASE
 OUTPUT FILE POSITIONS...18 WITH AUX. OUTPUT FILE
 LOAD SWITCHES USED.....S1,S2,S3,S4,S5,S6,S9,S12
 PHASES USED.....1,2,3,4,5,6
 OVERLAP "A".....1+2
 OVERLAP "B".....NOT USED
 OVERLAP "C".....5+6
 OVERLAP "D".....NOT USED

4 SECTION FYA PPLT SIGNAL WIRING DETAIL

(wire signal heads as shown)

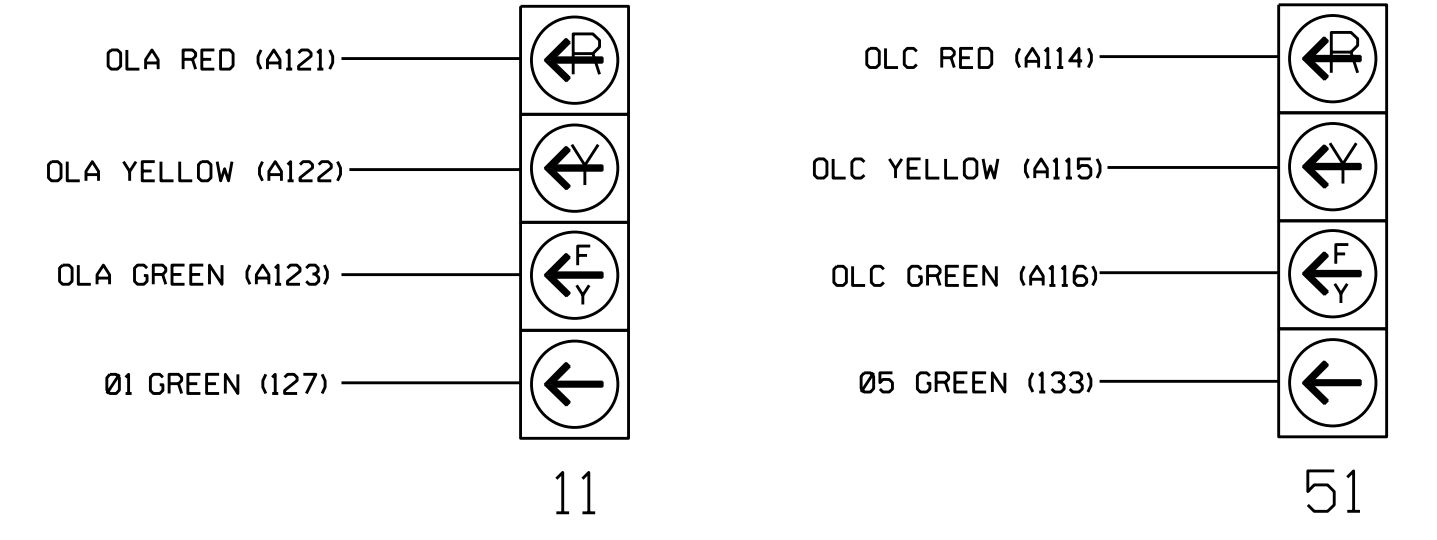

NOTE

- The sequence display for this signal requires special logic programming. See sheet 2 for programming instructions.

INPUT FILE POSITION LAYOUT

(front view)

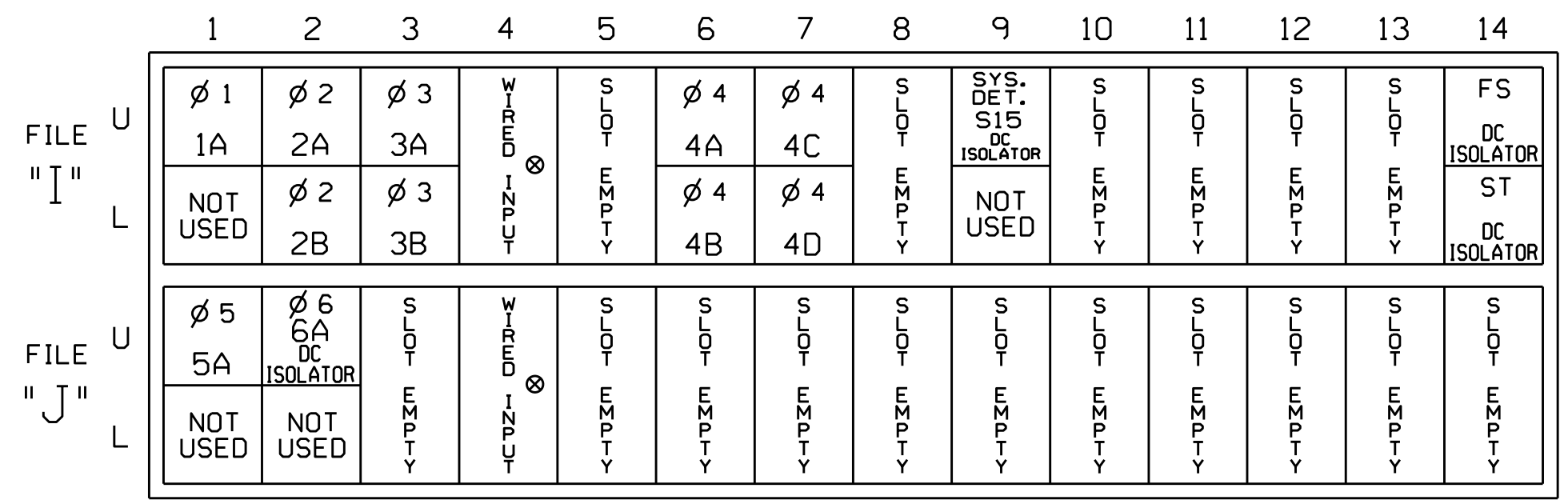

EX.: 1A, 2A, ETC. = LOOP NO.'S

FS = FLASH SENSE
 ST = STOP TIME

⊗ Wired Input - Do not populate slot with detector card

Note: Install a model 242 DC isolator in slots 19 and J2 for use with a microwave detector. See the Microwave Detector Wiring Details on sheets 3-4.

! IMPORTANT: For proper operation of the microwave detector, remove surge protection from the following terminals:
 TB3-5, TB3-6, TB3-7 and TB3-8
 TB6-9, TB6-10, TB6-11 and TB6-12

INPUT FILE CONNECTION & PROGRAMMING CHART

LOOP NO.	LOOP TERMINAL	INPUT FILE POS.	PIN NO.	INPUT ASSIGNMENT NO.	DETECTOR NO.	NEMA PHASE	CALL	EXTEND	FULL TIME DELAY	STRETCH TIME	DELAY TIME
1A ¹	TB2-1,2	I1U	56	18	1	1	Y	Y			15
		J4U	48	10	26	6	Y	Y	Y		3
2A	TB2-5,6	I2U	39	1	2	2	Y	Y			
2B	TB2-7,8	I2L	43	5	12	2	Y	Y			
3A	TB2-9,10	I3U	63	25	32	3	Y	Y			3
3B	TB2-11,12	I3L	76	38	42	3	Y	Y			10
4A	TB4-9,10	I6U	41	3	4	4	Y	Y			3
4B	TB4-11,12	I6L	45	7	14	4	Y	Y			3
4C	TB6-1,2	I7U	65	27	34	4	Y	Y			10
4D	TB6-3,4	I7L	78	40	44	4	Y	Y			15
5A ²		J1U	55	17	5	5	Y	Y			15
		I4U	47	9	22	2	Y	Y	Y		3
6A	TB3-5,6	J2U	40	2	6	6	Y	Y			
** S15	TB6-9,10	I9U	60	22	11	SYS					

**

- Add jumper from I1-W to J4-W, on rear of input file.
- Add jumper from J1-W to I4-W, on rear of input file.

** Microwave detector - see wiring details on sheets 3 and 4.

* System detector only. Remove the vehicle phase assigned to this detector in the default programming.

INPUT FILE POSITION LEGEND: J2L

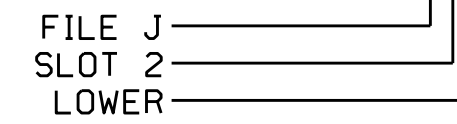

LOAD RESISTOR INSTALLATION DETAIL

(install resistors as shown below)

ACCEPTABLE VALUES	
VALUE (ohms)	WATTAGE
1.5K - 1.9K	25W (min)
2.0K - 3.0K	10W (min)

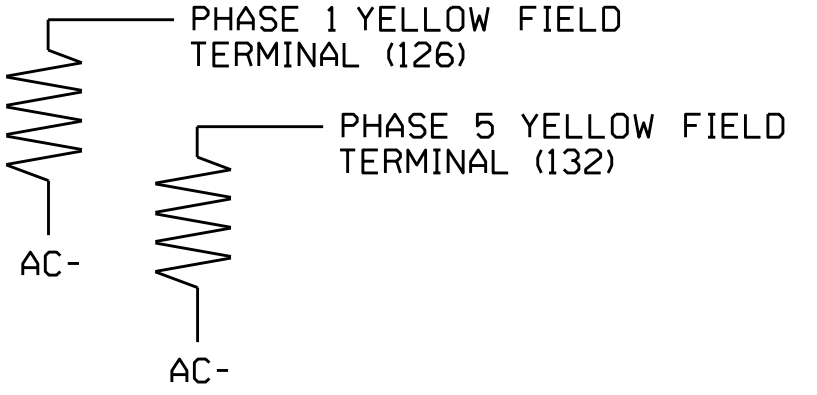

THIS ELECTRICAL DETAIL IS FOR THE SIGNAL DESIGN: 10-0820 T3
 DESIGNED: November 2014
 SEALED: 12-15-14
 REVISED: N/A

ELECTRICAL DETAIL SHEET 1 OF 4

Electrical and Programming Details For: US 29-601 / US 29-601-NC 73 (Concord Parkway North) at NC 73 (Davidson Parkway) / Florence Street

Prepared In the Offices of: **Transporatio Mobility and Safety Solutions**

Division 10 Cabarrus County as Concord

PLAN DATE: December 2014 REVIEWED BY: *JTR*

PREPARED BY: James Peterson REVIEWED BY:

REVISIONS INIT. DATE

Seal: **John T. Rowe, Jr.** 12/17/2014

SIG. INVENTORY NO. 10-0820 T3

16-JEC-2014_07-31
 S:\TCS\115_Sigma\work\kg\caus45\g_Mar\ Peterson\100820_sme.e_20110128.dgn
 J Peterson