

MICROWAVE DETECTOR WIRING DETAIL

(wire as shown)

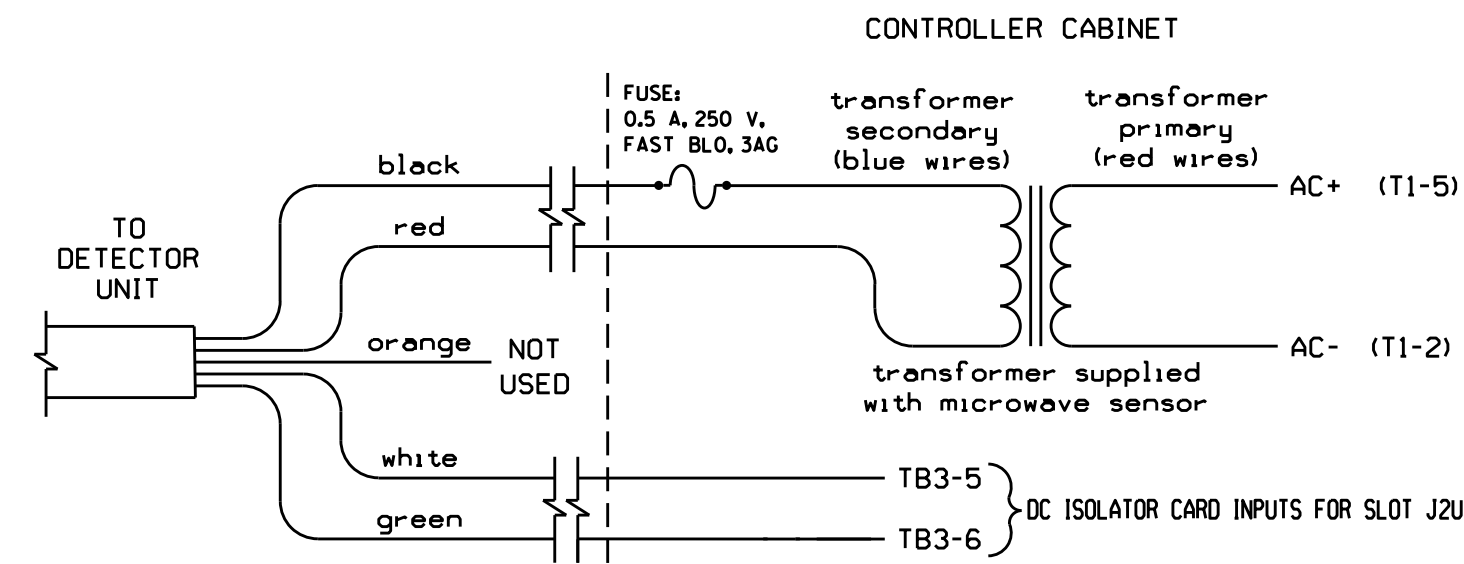

TC26B WIRE LIST

COLOR	FUNCTION
black	12V to 24V AC/DC (no polarity)
red	12V to 24V AC/DC (no polarity)
orange	Output Relay Normally Open
white	Output Relay Normally Closed
green	Output Relay Common

NOTES:

- Sensor is a microwave motion detector mounted on poles as indicated on the Signal Design Plans.
- Microwave wiring shown above will cause a permanent call unless the Input Assignment Programming and Logical I/O Processor Programming details are entered as shown on this sheet and sheet 2. These programming details will cause a call to be placed upon opening the Normally Closed contact.
- DC Isolator's LED will be ON when no call is present and will be OFF when a call is present.
- Important: For proper operation of the microwave detector, remove surge protection from TB3-5, TB3-6, TB3-7, and TB3-8 and insert 242 DC Isolator in slot J2.

INPUT ASSIGNMENT PROGRAMMING DETAIL FOR MICROWAVE DETECTOR INPUT (DETECTOR #6)

(program controller as shown below)

FROM MAIN MENU PRESS '5' (INPUTS), THEN '+' UNTIL INPUT 2 (PIN 40) IS REACHED. MODIFY DEFAULT CONDITIONS AS INDICATED BY ARROWS.

```

PAGE: 1 C1 PIN:40 NOT ENABLED
INPUT ASSIGNMENT #.....2
DEBOUNCE TIME (0-25.5 SEC).....0.5
DELAY TIME (0-25.5 SEC).....0.0
HOLD-OVER TIME (0-25.5 SEC).....0.0
ASSIGNMENT SELECTION:
NOT ENABLED (Y/N).....Y
VEHICLE DETECTOR (1-64).....-
PEDESTRIAN DETECTOR (1-16).....-
ALTERNATE PED DETECTOR (1-16).....-
PREEMPT (1-10).....-
INVERTED PREEMPT (1-10).....-
STOP TIME (Y/N).....-
FLASH SENSE (Y/N).....-
DOOR OPEN (Y/N).....-
MANUAL CONTROL ENABLE (Y/N).....-
MANUAL CONTROL ADVANCE (Y/N).....-
SPECIAL FUNCTION ALARM (1-8).....-
TOD HOUR SYNCHRONIZATION (0-23).....-
FORCE OFF RING (1-4).....-
HOLD PHASES (1-16).....-
PLAN (65=FLSH,66=FREE)... OFFSET#...
CHANGE PHASE SEQUENCE PAGE (1-12)...
CHANGE PHASE TIMING PAGE (1-4).....
CHANGE PHASE CONTROL PAGE (1-4).....
CHANGE OVERLAP CONTROL PAGE (1-4).....
CHANGE INPUT PAGE (1-4).....
CHANGE OUTPUT PAGE (1-4).....
OVERRIDE PHASE CONTROL FUNCTION (Y)...
    
```

ENTER 'YES' for Not Enabled

```

PAGE: 1 C1 PIN:0 VEHICLE DETECTOR
INPUT ASSIGNMENT #.....64
DEBOUNCE TIME (0-25.5 SEC).....0.5
DELAY TIME (0-25.5 SEC).....0.0
HOLD-OVER TIME (0-25.5 SEC).....0.0
ASSIGNMENT SELECTION:
NOT ENABLED (Y/N).....-
VEHICLE DETECTOR (1-64).....6
PEDESTRIAN DETECTOR (1-16).....-
ALTERNATE PED DETECTOR (1-16).....-
PREEMPT (1-10).....-
INVERTED PREEMPT (1-10).....-
STOP TIME (Y/N).....-
FLASH SENSE (Y/N).....-
DOOR OPEN (Y/N).....-
MANUAL CONTROL ENABLE (Y/N).....-
MANUAL CONTROL ADVANCE (Y/N).....-
SPECIAL FUNCTION ALARM (1-8).....-
TOD HOUR SYNCHRONIZATION (0-23).....-
FORCE OFF RING (1-4).....-
HOLD PHASES (1-16).....-
PLAN (65=FLSH,66=FREE)...65 OFFSET#...
CHANGE PHASE SEQUENCE PAGE (1-12)...
CHANGE PHASE TIMING PAGE (1-4).....
CHANGE PHASE CONTROL PAGE (1-4).....
CHANGE OVERLAP CONTROL PAGE (1-4).....
CHANGE INPUT PAGE (1-4).....
CHANGE OUTPUT PAGE (1-4).....
OVERRIDE PHASE CONTROL FUNCTION (Y)...
    
```

ENTER '6' for Vehicle Detector

PRESS '-' until Input Assignment #64 is reached

PROGRAMMING COMPLETE

NOTE:

This remapping removes the default detector from the microwave's physical input and reassigns it to unused INPUT 64. The Logical I/O Processor Programming Detail on sheet 2 will invert the disabled input and control INPUT 64 and the reassigned detector.

THIS ELECTRICAL DETAIL IS FOR THE SIGNAL DESIGN: 10-0820 T2
DESIGNED: November 2014
SEALED: 12-15-14
REVISED: N/A

ELECTRICAL DETAIL SHEET 3 OF 4

	US 29-601 / US 29-601-NC 73 (Concord Parkway North) at NC 73 (Davidson Parkway) / Florence Street	SEAL JOHN T. ROWE, JR. ENGINEER 008453
	Division 10 Cabarrus County ds Concord PLAN DATE: December 2014 REVIEWED BY: JTR PREPARED BY: James Peterson REVIEWED BY:	DocuSigned by: John T. Rowe, Jr. 12/17/2014 SIGNATURE DATE