

|  |   |   |  |
|--|---|---|--|
| <p>PI Sta 42+81.44<br/> <math>\Delta = 31^{\circ} 41' 12.4''</math> (RT)<br/> <math>D = 16^{\circ} 51' 06.1''</math><br/> <math>L = 188.03'</math><br/> <math>T = 96.49'</math><br/> <math>R = 340.00'</math><br/> <math>SE = 0.06</math><br/> <math>R = 120'</math></p> | <p>PI Sta 45+75.74<br/> <math>\Delta = 61^{\circ} 37' 04.4''</math> (LT)<br/> <math>D = 16^{\circ} 51' 06.1''</math><br/> <math>L = 365.65'</math><br/> <math>T = 202.75'</math><br/> <math>R = 340.00'</math><br/> <math>SE = 0.06</math><br/> <math>R = 120'</math></p> | <p>PI Sta 49+42.20<br/> <math>\Delta = 5^{\circ} 29' 56.3''</math> (RT)<br/> <math>D = 5^{\circ} 43' 46.5''</math><br/> <math>L = 95.98'</math><br/> <math>T = 48.02'</math><br/> <math>R = 1,000.00'</math><br/> <math>SE = 0.043</math><br/> <math>R = 87'</math></p> | <p>PI Sta 52+25.94<br/> <math>\Delta = 15^{\circ} 08' 31.2''</math> (LT)<br/> <math>D = 6^{\circ} 44' 26.4''</math><br/> <math>L = 224.64'</math><br/> <math>T = 112.98'</math><br/> <math>R = 850.00'</math><br/> <math>SE = 0.046</math><br/> <math>R = 92'</math></p> |
|--|---|---|--|

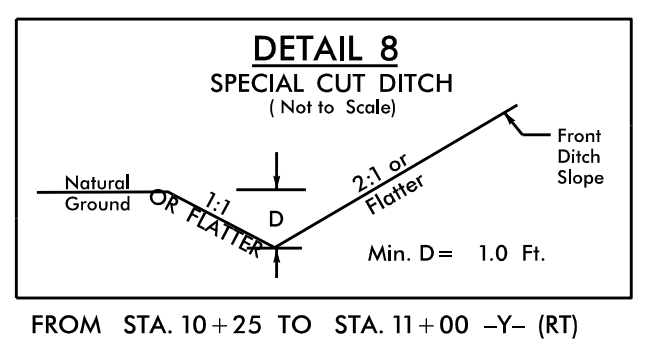
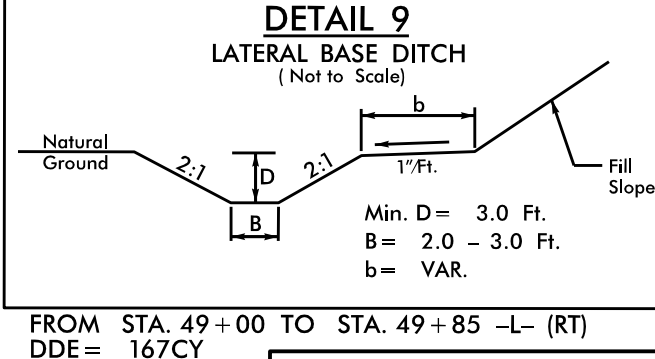
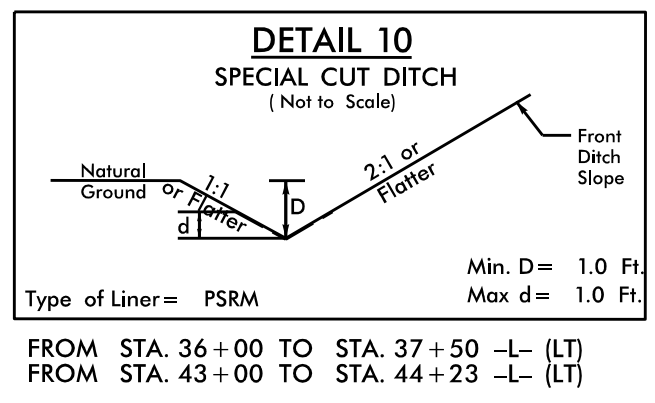
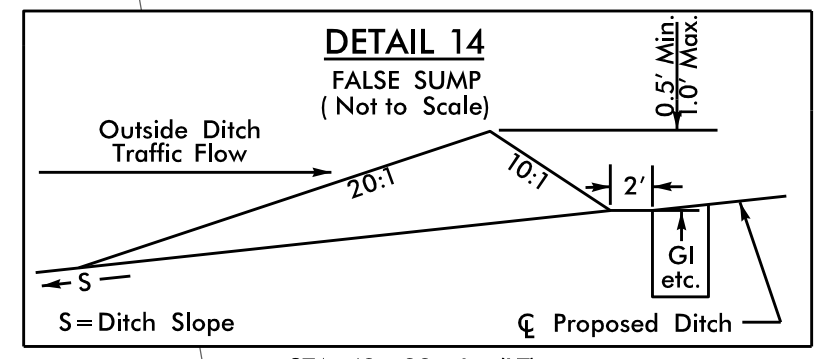

MATCHLINE -L- STA. 39+50 SEE SHEET 5

MATCHLINE -L- STA. 53+50 SEE SHEET 7

Z CLAIM DETAILS FOR PARCELS 23A, 29, AND 31

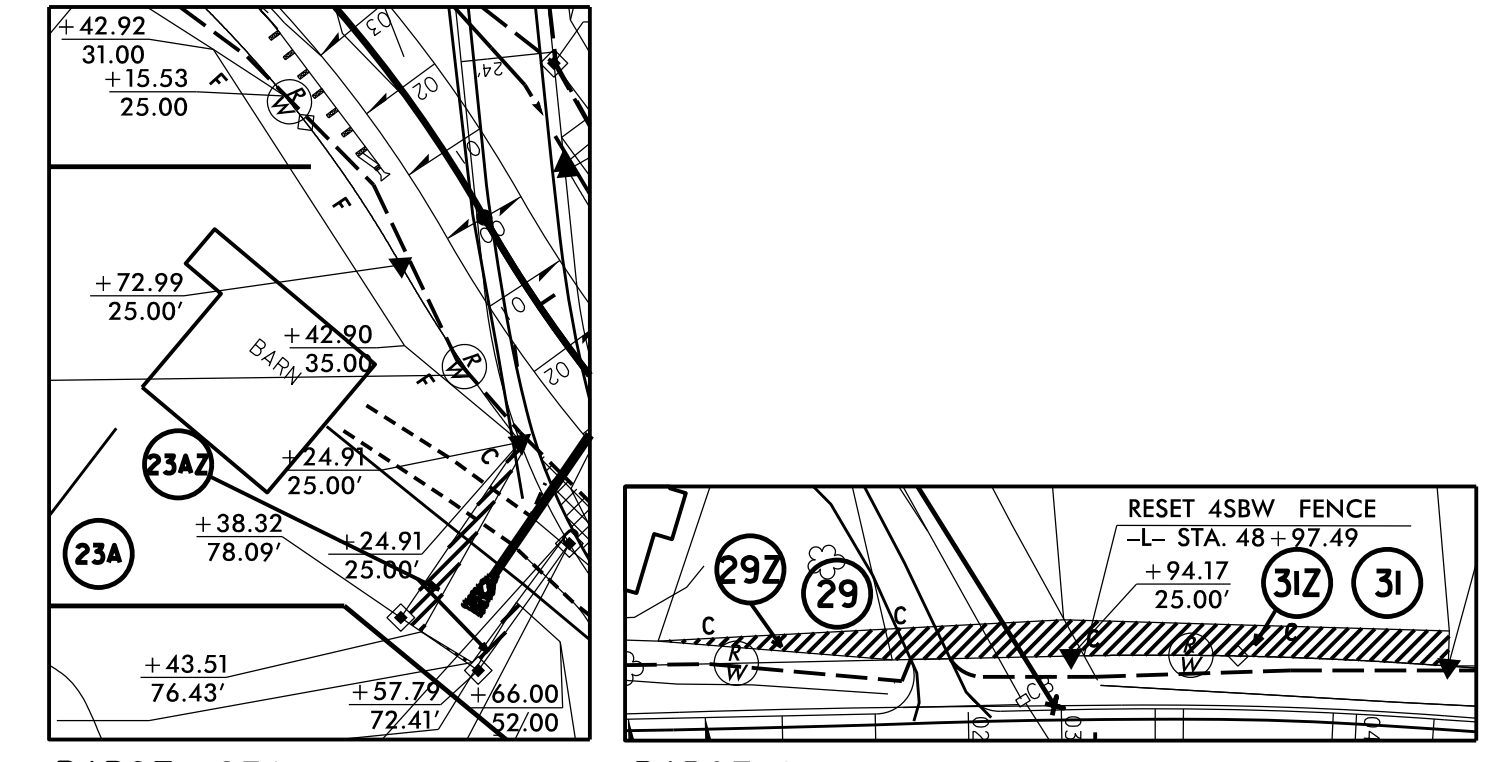

PARCEL 23A PARCELS 29 AND 31

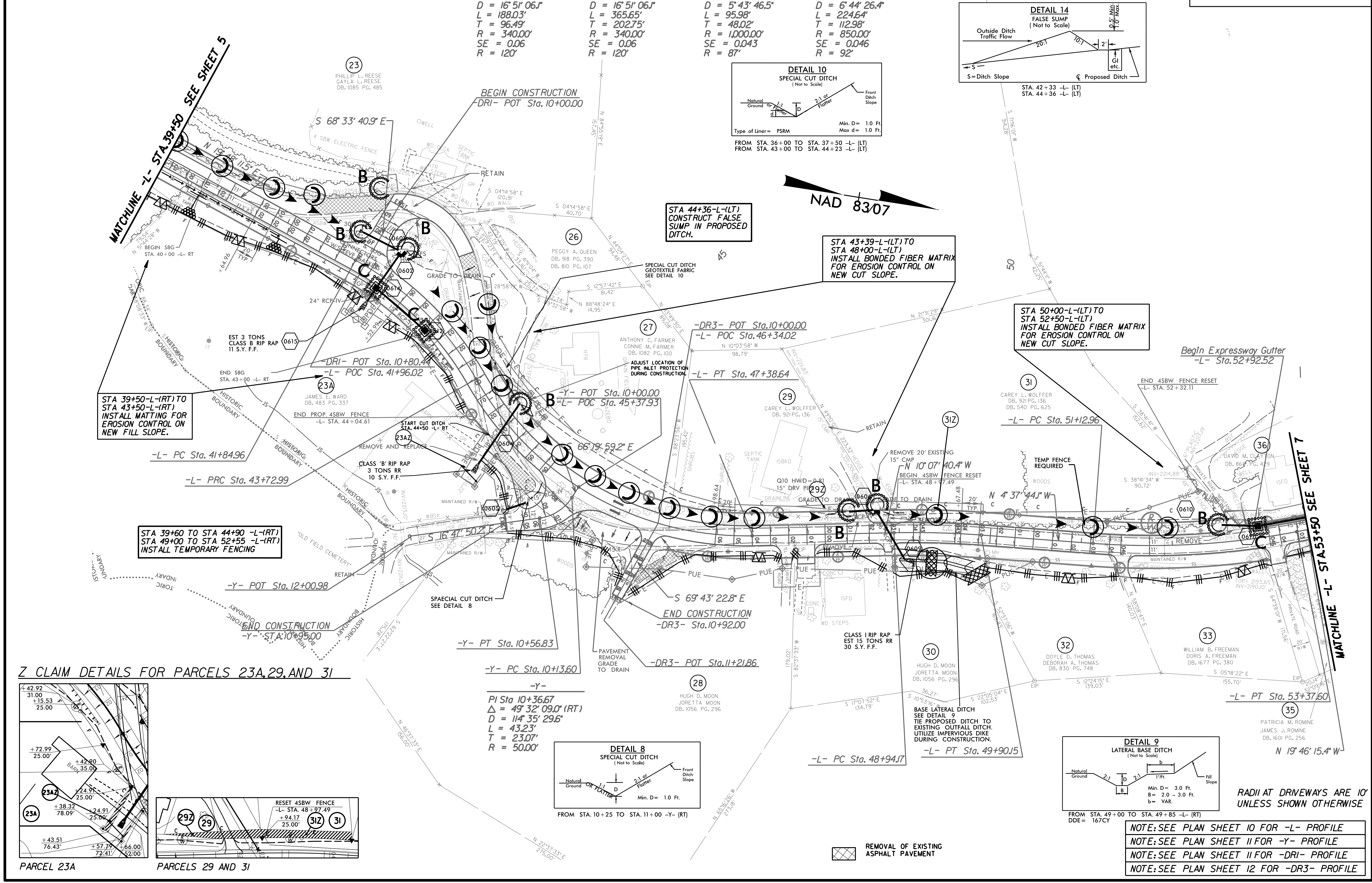

NOTE: SEE PLAN SHEET 10 FOR -L- PROFILE  
 NOTE: SEE PLAN SHEET 11 FOR -Y- PROFILE  
 NOTE: SEE PLAN SHEET 11 FOR -DRI- PROFILE  
 NOTE: SEE PLAN SHEET 12 FOR -DR3- PROFILE

RADII AT DRIVEWAYS ARE 10' UNLESS SHOWN OTHERWISE