

 ENVIRONMENTALLY SENSITIVE AREA
SEE PROJECT SPECIAL PROVISIONS

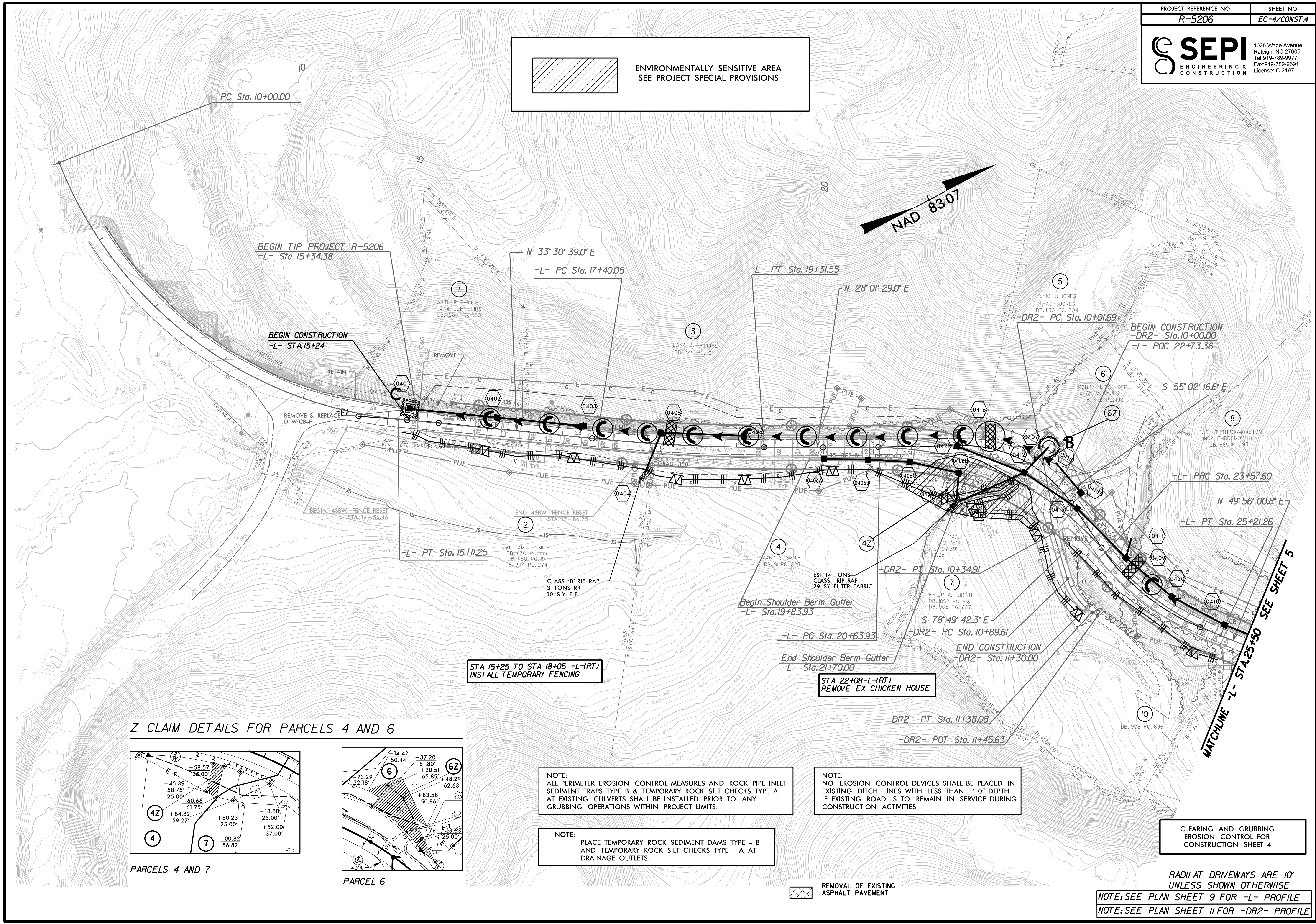

Z CLAIM DETAILS FOR PARCELS 4 AND 6

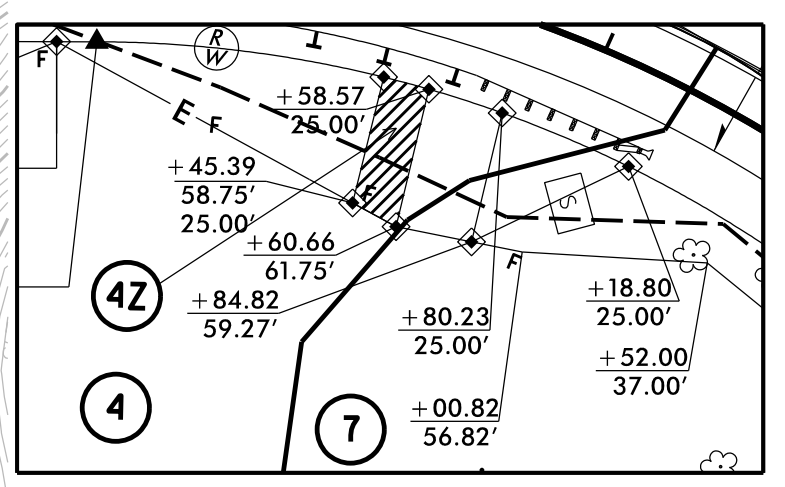

PARCELS 4 AND 7

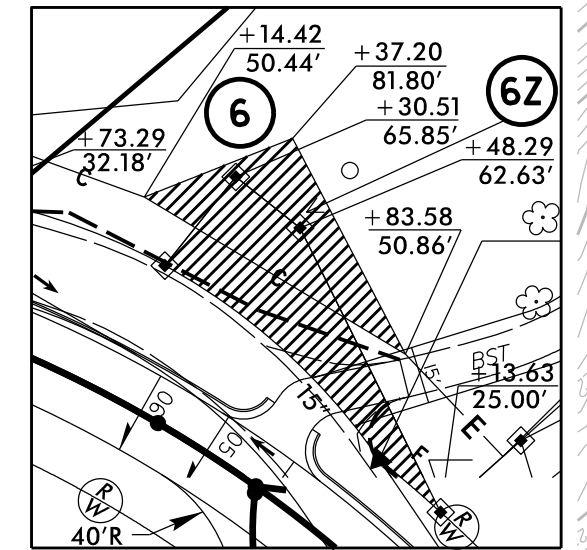

PARCEL 6

STA 15+25 TO STA 18+05 -L-(RT)
INSTALL TEMPORARY FENCING

NOTE:
ALL PERIMETER EROSION CONTROL MEASURES AND ROCK PIPE INLET SEDIMENT TRAPS TYPE B & TEMPORARY ROCK SILT CHECKS TYPE A AT EXISTING CULVERTS SHALL BE INSTALLED PRIOR TO ANY GRUBBING OPERATIONS WITHIN PROJECT LIMITS.

NOTE:
PLACE TEMPORARY ROCK SEDIMENT DAMS TYPE - B AND TEMPORARY ROCK SILT CHECKS TYPE - A AT DRAINAGE OUTLETS.

NOTE:
NO EROSION CONTROL DEVICES SHALL BE PLACED IN EXISTING DITCH LINES WITH LESS THAN 1'-0" DEPTH IF EXISTING ROAD IS TO REMAIN IN SERVICE DURING CONSTRUCTION ACTIVITIES.

STA 22+08-L-(RT)
REMOVE EX CHICKEN HOUSE

 REMOVAL OF EXISTING ASPHALT PAVEMENT

CLEARING AND GRUBBING
EROSION CONTROL FOR
CONSTRUCTION SHEET 4

RADI AT DRIVEWAYS ARE 10'
UNLESS SHOWN OTHERWISE
NOTE: SEE PLAN SHEET 9 FOR -L- PROFILE
NOTE: SEE PLAN SHEET 11 FOR -DR2- PROFILE

MATCHLINE -L- STA 25+50 SEE SHEET 5