

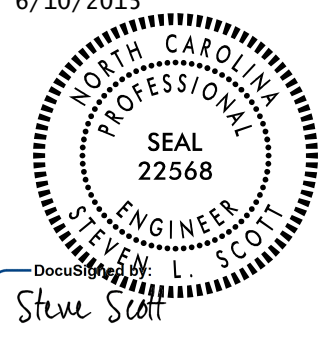

PROJECT REFERENCE NO. R-5206	SHEET NO. 8
RW SHEET NO.	
ROADWAY DESIGN ENGINEER 6/10/2015 	HYDRAULICS ENGINEER 6/12/2015 
 1025 Wade Avenue Raleigh, NC 27605 Tel: 919-789-9977 Fax: 919-789-9591 License: C-2197	

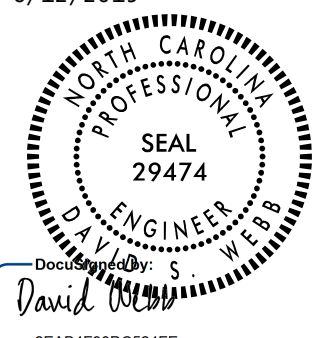

-L-

PI Sta 68+65.96 $\Delta = 33' 17" 38.1" (LT)$ $D = 16' 51" 06.1"$ $L = 197.57'$ $T = 101.66'$ $R = 340.00'$ $SE = 0.06$ $RUNOFF = 120'$	PI Sta 71+51.45 $\Delta = 19' 33" 27.9" (LT)$ $D = 5' 12" 31.3"$ $L = 375.48'$ $T = 189.59'$ $R = 1100.00'$ $SE = 0.04$ $RUNOFF = 80'$	PI Sta 75+57.55 $\Delta = 5' 21" 30.0" (RT)$ $D = 3' 10" 59.2"$ $L = 168.34'$ $T = 84.23'$ $R = 1,800.00'$
---	--	--

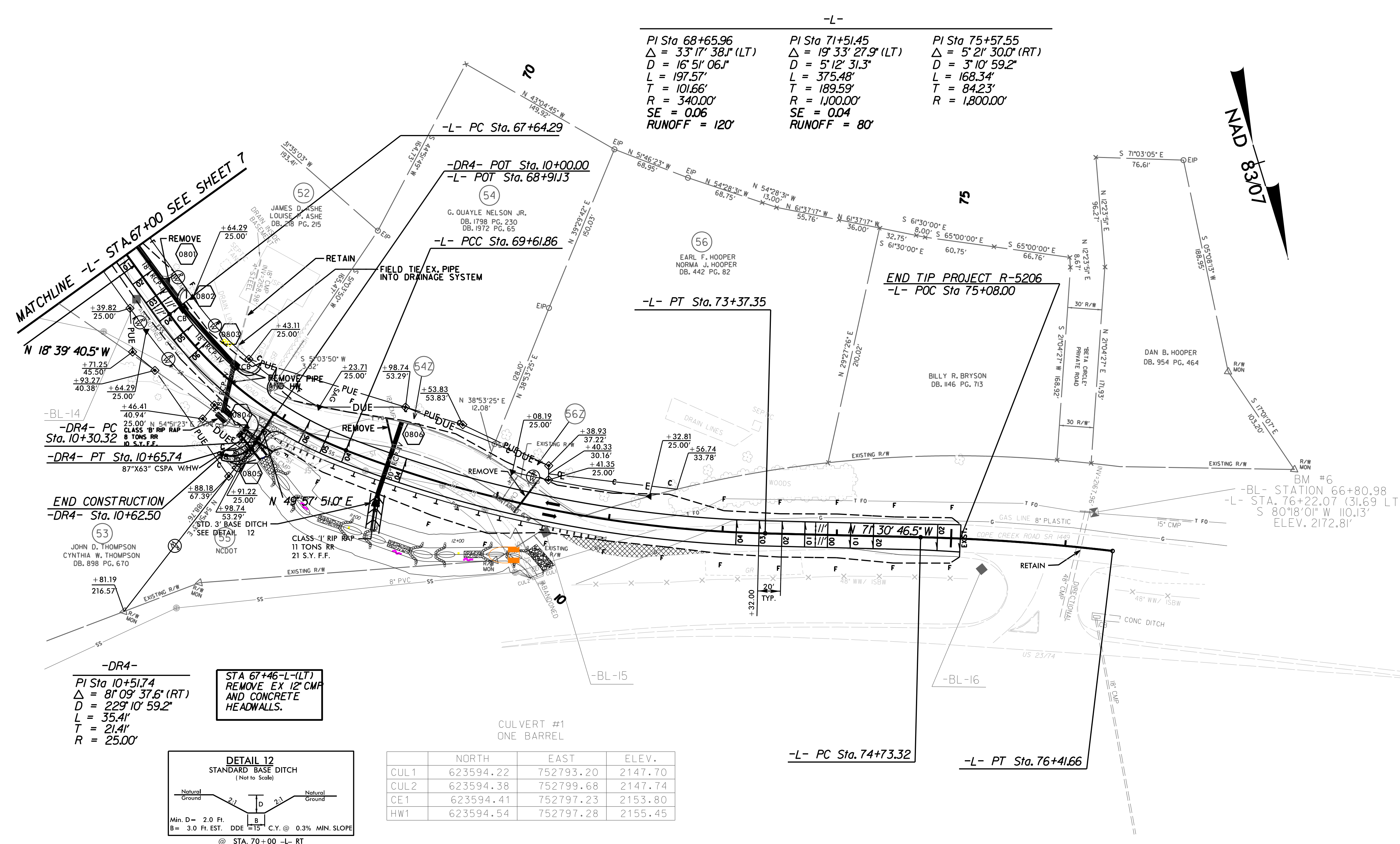
-DR4-
PI Sta 10+51.74
 $\Delta = 8' 09" 37.6" (RT)$
 $D = 229' 10" 59.2"$
 $L = 35.41'$
 $T = 21.41'$
 $R = 25.00'$

STA 67+46-L (LT)
 REMOVE EX 12' CMP
 AND CONCRETE
 HEADWALLS.

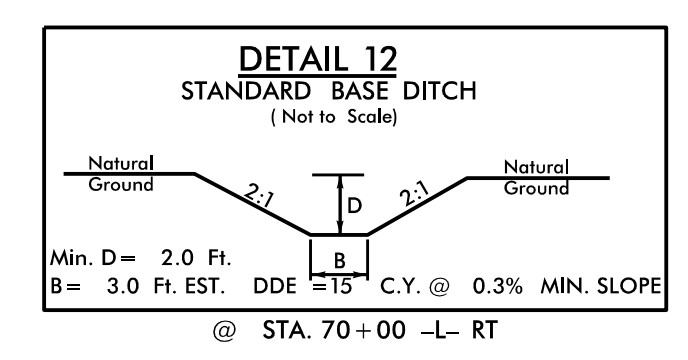

	NORTH	EAST	ELEV.
CUL1	623594.22	752793.20	2147.70
CUL2	623594.38	752799.68	2147.74
CE1	623594.41	752797.23	2153.80
HW1	623594.54	752797.28	2155.45

Z CLAIM DETAILS FOR PARCELS 54, AND 56

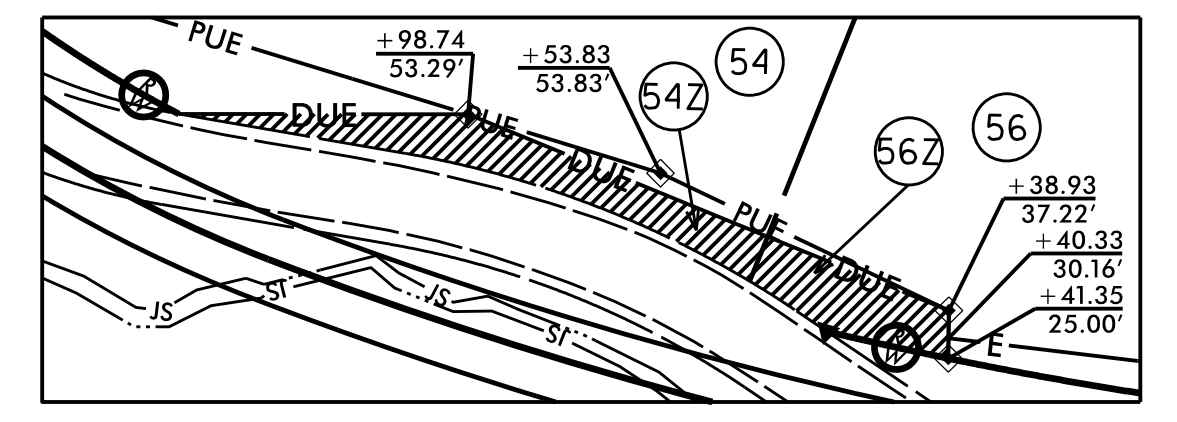

PARCELS 54 AND 56

 REMOVAL OF EXISTING ASPHALT PAVEMENT

RADIAT DRIVEWAYS ARE 10'
 UNLESS SHOWN OTHERWISE

NOTE: SEE PLAN SHEET 11 FOR -L- PROFILE
 NOTE: SEE PLAN SHEET 12 FOR -DR4- PROFILE

REVISIONS

5/14/99