

**This electronic collection of documents is provided
for the convenience of the user
and is Not a Certified Document –**

**The documents contained herein were originally issued
and sealed by the individuals whose names and license
numbers appear on each page, on the dates appearing
with their signature on that page.**

**This file or an individual page
shall not be considered a certified document.**

STATE OF NORTH CAROLINA
DIVISION OF HIGHWAYS

TRANSPORTATION MANAGEMENT PLAN

ROCKINGHAM COUNTY

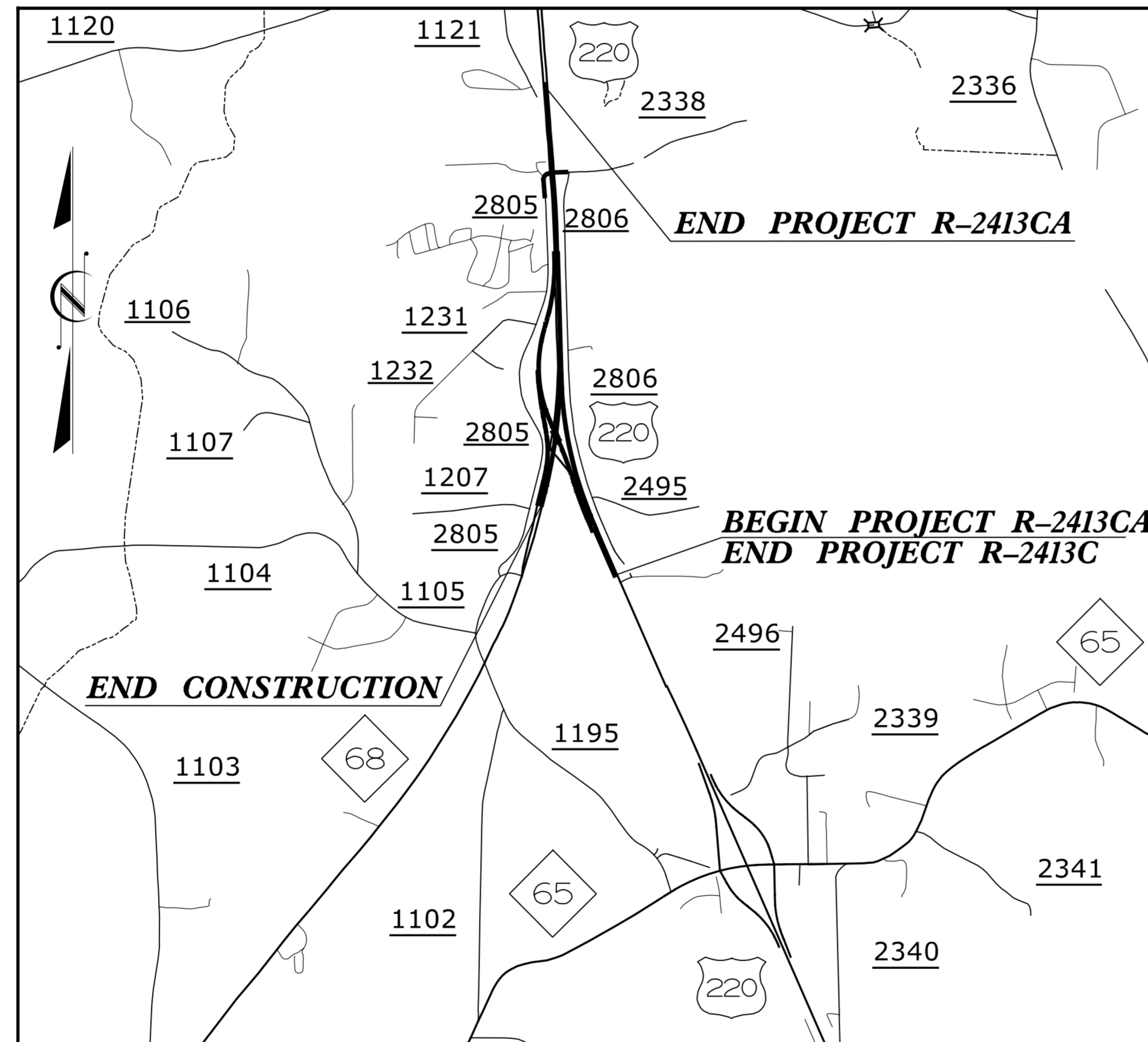
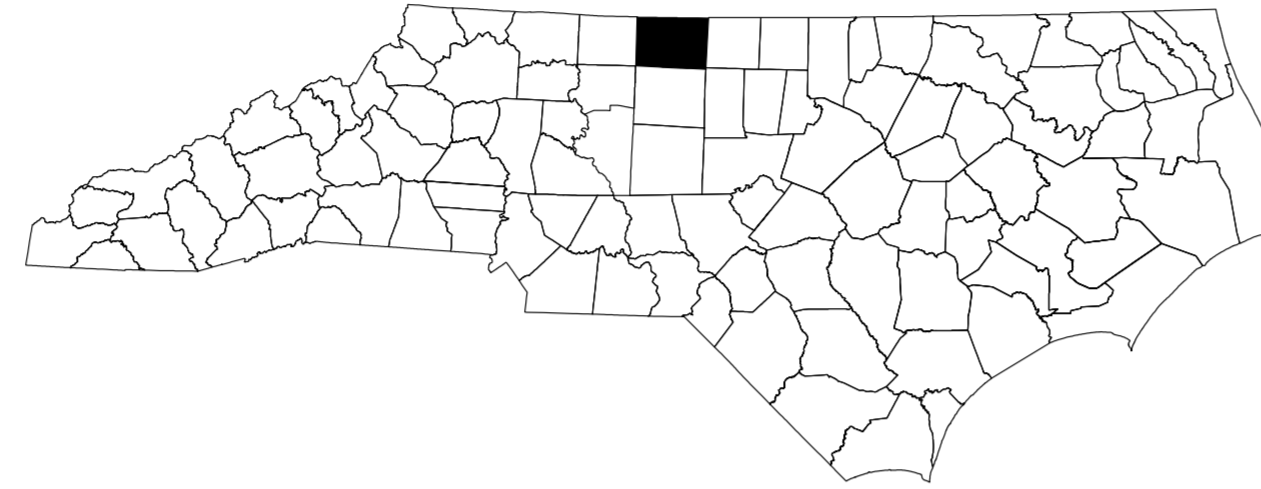

**SKETCH MAP SHOWING THE VICINITY OF
STATE PROJECTS R-2413CA**

INDEX OF SHEETS	
SHEET NO.	TITLE
TMP-1	TITLE SHEET, AND INDEX OF SHEETS
TMP-1A	LIST OF APPLICABLE ROADWAY STANDARD DRAWINGS, LEGEND, AND TEMPORARY PAVEMENT MARKING
TMP-1B & 1C	TRANSPORTATION OPERATIONS PLAN: (MANAGEMENT STRATEGIES, GENERAL NOTES AND LOCAL NOTES)
TMP-2A	NC 68 DETOUR ROUTE
TMP-3A & 3B	PHASING
TMP-4	PHASE I OVERVIEW
TMP-5 THRU 9	PHASE I, STEP 2 DETAILS
TMP-10 & 11	PHASE I, STEP 3 DETAILS
TMP-12	PHASE II OVERVIEW
TMP-13 THRU 17	PHASE II, STEP 1 DETAILS
TMP-18	PHASE III OVERVIEW
TMP-19 & 20	PHASE III, STEP 1 DETAILS
TMP-21 THRU 28	PHASE III, STEP 2 DETAILS
TMP-29 THRU 33	PHASE III, STEP 3 DETAILS
TMP-34	PHASE IV OVERVIEW

SHEET NO.

TMP-1

R-2413CA

TIP PROJECT:

2/11/2015 R:\TrafficControl\TCP\2413ca_top_title.dgn Florence & Hutcheson, Inc.

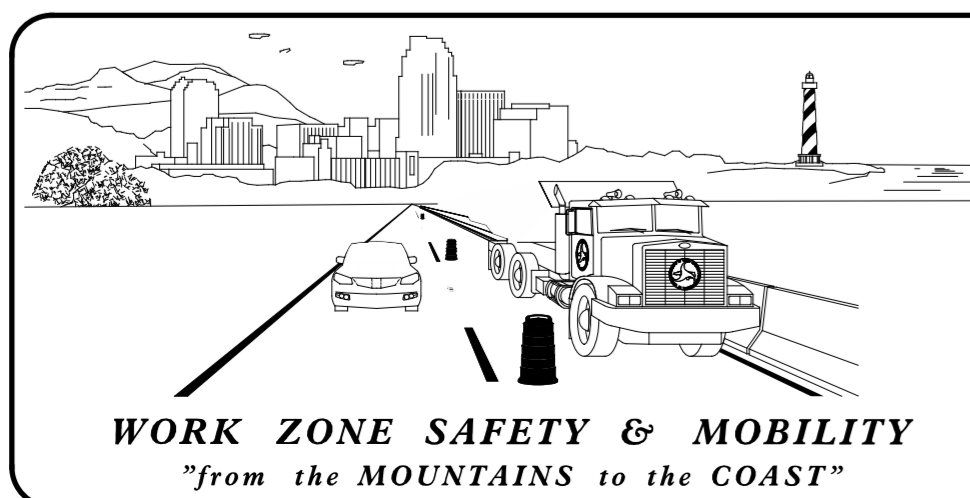

N.C.D.O.T. WORK ZONE TRAFFIC CONTROL
1580 MAIL SERVICE CENTER (MSC) RALEIGH, NC 27699-1580
1020 BIRCH RIDGE DRIVE, RALEIGH, NC 27610 (DELIVERY)
PHONE: (919) 250-4094 FAX: (919) 250-4098

J. S. BOURNE, P.E. STATE TRAFFIC MANAGEMENT ENGINEER
D. BISSETTE, P.E. TRAFFIC CONTROL PROJECT ENGINEER
H. SHYU, P.E. TRAFFIC CONTROL PROJECT DESIGN ENGINEER
TRAFFIC CONTROL DESIGN ENGINEER



APPROVED: *Michael T. Rygpa*
DATE: 2/12/2015

SEAL
NORTH CAROLINA PROFESSIONAL ENGINEER SEAL 15876
MICHAEL T. RYGA



ROADWAY STANDARD DRAWINGS



THE FOLLOWING ROADWAY STANDARDS AS APPEAR IN "ROADWAY STANDARD DRAWINGS" - PROJECT SERVICES UNIT - N.C. DEPARTMENT OF TRANSPORTATION - RALEIGH, N.C., DATED JANUARY 2012 ARE APPLICABLE TO THIS PROJECT AND BY REFERENCE HEREBY ARE CONSIDERED A PART OF THESE PLANS:

STD. NO.	TITLE
1101.01	WORK ZONE ADVANCE WARNING SIGNS
1101.02	TEMPORARY LANE CLOSURES
1101.03	TEMPORARY ROAD CLOSURES
1101.04	TEMPORARY SHOULDER CLOSURES
1101.05	WORK ZONE VEHICLE ACCESSES
1101.11	TRAFFIC CONTROL DESIGN TABLES
1110.01	STATIONARY WORK ZONE SIGNS
1110.02	PORTABLE WORK ZONE SIGNS
1115.01	FLASHING ARROW BOARDS
1130.01	DRUM
1135.01	CONES
1145.01	BARRICADES
1150.01	FLAGGING DEVICES
1160.01	TEMPORARY CRASH CUSHION
1165.01	WORK VEHICLE LIGHTING SYSTEMS AND TMA DELINEATION
1170.01	POSITIVE PROTECTION
1180.01	SKINNY-DRUM
1205.01	PAVEMENT MARKINGS - LINE TYPES AND OFFSETS
1205.02	PAVEMENT MARKINGS - TWO-LANE AND MULTI-LANE ROADWAYS
1205.04	PAVEMENT MARKINGS - INTERSECTIONS
1205.06	PAVEMENT MARKINGS - LANE DROPS
1205.08	PAVEMENT MARKINGS - SYMBOLS AND WORD MESSAGES
1250.01	RAISED PAVEMENT MARKERS - INSTALLATION SPACING
1251.01	RAISED PAVEMENT MARKERS - PERMANENT AND TEMPORARY
1261.01	GUARDRAIL AND BARRIER DELINEATORS - INSTALLATION SPACING
1261.02	GUARDRAIL AND BARRIER DELINEATORS - TYPES AND MOUNTING
1262.01	GUARDRAIL END DELINEATION



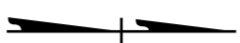







LEGEND

GENERAL

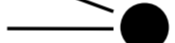

-  DIRECTION OF TRAFFIC FLOW
-  DIRECTION OF PEDESTRIAN TRAFFIC FLOW
- EXIST. PVMT.
-  NORTH ARROW
- PROPOSED PVMT.

-  WORK AREA
-  CONTINUING CONSTRUCTION
-  REMOVAL

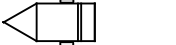

TRAFFIC CONTROL DEVICES

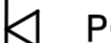
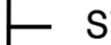
-  BARRICADE (TYPE III)
-  CONE
-  DRUM  SKINNY DRUM  TUBULAR MARKER
-  TEMPORARY CRASH CUSHION
-  FLASHING ARROW PANEL (TYPE C)
-  FLAGGER
-  LAW ENFORCEMENT
-  TRUCK MOUNTED IMPACT ATTENUATOR (TMIA)
-  CHANGEABLE MESSAGE SIGN

TEMPORARY SIGNING

-  PORTABLE SIGN
-  STATIONARY SIGN
-  STATIONARY OR PORTABLE SIGN



SIGNALS

-  EXISTING
-  PROPOSED
-  TEMPORARY

PAVEMENT MARKINGS

- EXISTING LINES
- TEMPORARY LINES

PAVEMENT MARKERS

-  CRYSTAL/CRYSTAL
-  CRYSTAL/RED
-  YELLOW/YELLOW

PAVEMENT MARKING SYMBOLS

-  PAVEMENT MARKING SYMBOLS

TEMPORARY PAVEMENT MARKING

SYMBOL	DESCRIPTION
<u>PAINT (4")</u>	
PA	WHITE EDGELINE
PB	YELLOW EDGELINE
PC	10 FT. WHITE SKIP
PD	2 FT. WHITE MINISKIP
PI	DOUBLE YELLOW CENTERLINE
<u>PAINT (8")</u>	
PP	YELLOW DIAGONAL
PR	WHITE GORELINE
<u>PAINT (24")</u>	
P2	WHITE STOP BAR
<u>PAINT SYMBOL</u>	
QB	RIGHT ARROW
QC	STRAIGHT ARROW
QI	ALPHANUMERIC CHARACTER
<u>TEMPORARY RAISED MARKERS</u>	
MH	YELLOW & YELLOW
MI	CRYSTAL & RED

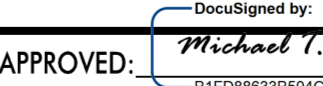
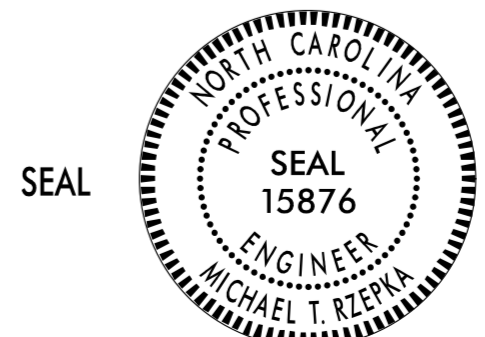
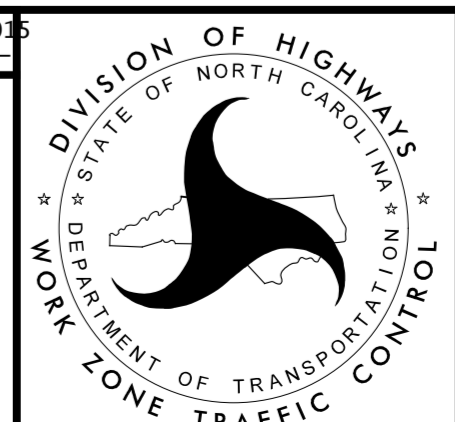
APPROVED:  DATE: 2/12/2015 		ROADWAY STANDARD DRAWINGS, LEGEND & TEMPORARY PAVEMENT MARKING SCHEDULE
--	---	--

GENERAL NOTES



CHANGES MAY BE REQUIRED WHEN PHYSICAL DIMENSIONS IN THE DETAIL DRAWINGS, STANDARD DETAILS, AND ROADWAY DETAILS ARE NOT ATTAINABLE TO MEET FIELD CONDITIONS OR RESULT IN DUPLICATE OR UNDESIRABLE OVERLAPPING OF DEVICES. MODIFICATION MAY INCLUDE: MOVING, SUPPLEMENTING, COVERING, OR REMOVAL OF DEVICES AS DIRECTED BY THE ENGINEER.

THE FOLLOWING GENERAL NOTES APPLY AT ALL TIMES FOR THE DURATION OF THE CONSTRUCTION PROJECT EXCEPT WHEN OTHERWISE NOTED IN THE PLAN OR DIRECTED BY THE ENGINEER.

TIME RESTRICTIONS

A) DO NOT CLOSE OR NARROW TRAVEL LANES AS FOLLOWS:

ROAD NAME	DAY AND TIME RESTRICTIONS
US 220 NC 68	MONDAY THRU FRIDAY 6:00AM - 9:00AM 4:00PM - 6:00PM

B) DO NOT CLOSE OR NARROW TRAVEL LANES DURING HOLIDAYS AND SPECIAL EVENTS AS FOLLOWS:

ROAD NAME

US 220
NC 68

HOLIDAY

- FOR ANY UNEXPECTED OCCURRENCE THAT CREATES UNUSUALLY HIGH TRAFFIC VOLUMES, AS DIRECTED BY THE ENGINEER.
- FOR NEW YEAR'S, BETWEEN THE HOURS OF 6:00 A.M. DECEMBER 31st TO 6:00 P.M. JANUARY 2ND. IF NEW YEAR'S DAY IS ON A FRIDAY, SATURDAY, SUNDAY, OR MONDAY THEN UNTIL 6:00 P.M. THE FOLLOWING TUESDAY.
- FOR EASTER, BETWEEN THE HOURS OF 6:00 A.M. THURSDAY AND 6:00 P.M. MONDAY.
- FOR MEMORIAL DAY, BETWEEN THE HOURS OF 6:00 A.M. FRIDAY TO 6:00 P.M. TUESDAY.
- FOR INDEPENDENCE DAY, BETWEEN THE HOURS OF 6:00 A.M. THE DAY BEFORE INDEPENDENCE DAY AND 6:00 P.M. THE DAY AFTER INDEPENDENCE DAY.

IF INDEPENDENCE DAY IS ON A FRIDAY, SATURDAY, SUNDAY OR MONDAY THEN BETWEEN THE HOURS OF 6:00 A.M. THE THURSDAY BEFORE INDEPENDENCE DAY AND 6:00 P.M. THE TUESDAY AFTER INDEPENDENCE DAY.
- FOR LABOR DAY, BETWEEN THE HOURS OF 6:00 A.M. FRIDAY AND 6:00 P.M. TUESDAY.
- FOR THANKSGIVING DAY, BETWEEN THE HOURS OF 6:00 A.M. TUESDAY TO 6:00 P.M. MONDAY.
- FOR CHRISTMAS, BETWEEN THE HOURS OF 6:00 A.M. THE FRIDAY BEFORE THE WEEK OF CHRISTMAS DAY AND 6:00 P.M. THE FOLLOWING TUESDAY AFTER THE WEEK OF CHRISTMAS.
- FOR RACES IN MARTINSVILLE, VIRGINIA, BETWEEN THE HOURS OF 6:00 A.M. THE FRIDAY OF THE WEEKEND OF THE RACE AND 6:00 P.M. THE FOLLOWING MONDAY AFTER THE WEEKEND OF THE RACE.

C) DO NOT CLOSE ROADS AS FOLLOWS:

ROAD NAME	DAY AND TIME RESTRICTIONS	DURATION AND OPERATION
NC 68	MONDAY THRU SUNDAY 6:00AM - 10:00PM	UP TO 8 HOURS (ACCOMPANIED WITH AN OFF-SITE DETOUR) GIRDER PLACEMENT

D) DO NOT STOP TRAFFIC AS FOLLOWS:

ROAD NAME	DAY AND TIME RESTRICTIONS	DURATION AND OPERATION
US 220 NC 68	MONDAY THRU SUNDAY 6:00AM - 10:00PM	UP TO 30 MINUTES TIE-INS AND TRAFFIC SHIFTS

E) DO NOT CONDUCT ANY HAULING OPERATIONS AGAINST THE FLOW OF TRAFFIC OF AN OPEN TRAVELWAY UNLESS THE HAULING OPERATION IS PROTECTED BY BARRIER OR GUARDRAIL OR AS DIRECTED BY THE ENGINEER.

LANE AND SHOULDER CLOSURE REQUIREMENTS

F) REMOVE LANE CLOSURE DEVICES FROM THE LANE WHEN WORK IS NOT BEING PERFORMED BEHIND THE LANE CLOSURE OR WHEN A LANE CLOSURE IS NO LONGER NEEDED OR AS DIRECTED BY THE ENGINEER.

G) WHEN PERSONNEL AND/OR EQUIPMENT ARE WORKING WITHIN 4.5 M OF AN OPEN TRAVEL LANE, CLOSE THE NEAREST OPEN SHOULDER USING ROADWAY STANDARD DRAWING NO. 1101.04 UNLESS THE WORK AREA IS PROTECTED BY BARRIER OR GUARDRAIL OR A LANE CLOSURE IS INSTALLED.

H) WHEN PERSONNEL AND/OR EQUIPMENT ARE WORKING ON THE SHOULDER ADJACENT TO AN UNDIVIDED FACILITY AND WITHIN 1.5 M OF AN OPEN TRAVEL LANE, CLOSE THE NEAREST OPEN TRAVEL LANE USING ROADWAY STANDARD DRAWING NO. 1101.02 UNLESS THE WORK AREA IS PROTECTED BY BARRIER OR GUARDRAIL.

WHEN PERSONNEL AND/OR EQUIPMENT ARE WORKING ON THE SHOULDER ADJACENT TO A DIVIDED FACILITY AND WITHIN 3.0 M OF AN OPEN TRAVEL LANE, CLOSE THE NEAREST OPEN TRAVEL LANE USING ROADWAY STANDARD DRAWING NO. 1101.02 UNLESS THE WORK AREA IS PROTECTED BY BARRIER OR GUARDRAIL.

I) WHEN PERSONNEL AND/OR EQUIPMENT ARE WORKING WITHIN A LANE OF TRAVEL OF AN UNDIVIDED OR DIVIDED FACILITY, CLOSE THE LANE ACCORDING TO THE TRAFFIC CONTROL PLANS, ROADWAY STANDARD DRAWINGS, OR AS DIRECTED BY THE ENGINEER. CONDUCT THE WORK SO THAT ALL PERSONNEL AND/OR EQUIPMENT REMAIN WITHIN THE CLOSED TRAVEL LANE.

J) DO NOT WORK SIMULTANEOUSLY WITHIN 4.5 M ON BOTH SIDES OF AN OPEN TRAVELWAY, RAMP, OR LOOP WITHIN THE SAME LOCATION UNLESS PROTECTED WITH GUARDRAIL OR BARRIER.

K) DO NOT INSTALL MORE THAN 1.6 KM OF LANE CLOSURE ON US 220 MEASURED FROM THE BEGINNING OF THE MERGE TAPER TO THE END OF THE LANE CLOSURE.

L) DO NOT INSTALL MORE THAN THREE SIMULTANEOUS LANE CLOSURES IN ANY ONE DIRECTION ON US 220.

M) PROVIDE A MINIMUM OF 3.2 KM BETWEEN LANE CLOSURES, MEASURED FROM THE END OF ONE CLOSURE TO THE FIRST SIGN OF THE NEXT LANE CLOSURE.

N) PROVIDE TRAFFIC CONTROL FOR APPROPRIATE LANE CLOSURES FOR SURVEYING DONE BY THE DEPARTMENT.

PAVEMENT EDGE DROP OFF REQUIREMENTS

O) BACKFILL AT A 6:1 SLOPE UP TO THE EDGE AND ELEVATION OF EXISTING PAVEMENT IN AREAS ADJACENT TO AN OPENED TRAVEL LANE THAT HAS AN EDGE OF PAVEMENT DROP-OFF AS FOLLOWS:

BACKFILL DROP-OFFS THAT EXCEED 5 CM ON ROADWAYS WITH POSTED SPEED LIMITS OF 45 MPH OR GREATER.

BACKFILL DROP-OFFS THAT EXCEED 7.5 CM ON ROADWAYS WITH POSTED SPEED LIMITS LESS THAN 45 MPH.

BACKFILL WITH SUITABLE COMPACTED MATERIAL, AS APPROVED BY THE ENGINEER, AT NO EXPENSE TO THE DEPARTMENT.

P) DO NOT EXCEED A DIFFERENCE OF 5 CM IN ELEVATION BETWEEN OPEN LANES OF TRAFFIC FOR NOMINAL LIFTS OF 3.8 CM. INSTALL ADVANCE WARNING "UNEVEN LANES" SIGNS (W8-11) 61 M IN ADVANCE AND A MINIMUM OF EVERY .8 KM THROUGHOUT THE UNEVEN AREA.

TRAFFIC PATTERN ALTERATIONS

Q) NOTIFY THE ENGINEER TWENTY ONE (21) CALENDAR DAYS PRIOR TO ANY TRAFFIC PATTERN ALTERATION.

SIGNING

R) INSTALL ADVANCE WORK ZONE WARNING SIGNS WHEN WORK IS WITHIN 12.2 M FROM THE EDGE OF TRAVEL LANE AND NO MORE THAN THREE (3) DAYS PRIOR TO THE BEGINNING OF CONSTRUCTION.

S) PROVIDE SIGNING AND DEVICES REQUIRED TO CLOSE THE ROAD ACCORDING TO THE ROADWAY STANDARD DRAWINGS AND TRAFFIC CONTROL PLANS.

PROVIDE SIGNING REQUIRED FOR THE OFF-SITE DETOUR ROUTE AS SHOWN IN THE TRAFFIC CONTROL PLANS.

T) COVER OR REMOVE ALL SIGNS AND DEVICES REQUIRED TO CLOSE THE ROAD WHEN ROAD CLOSURE IS NOT IN OPERATION.

COVER OR REMOVE ALL SIGNS REQUIRED FOR THE OFF-SITE DETOUR WHEN THE DETOUR IS NOT IN OPERATION.

U) ENSURE ALL NECESSARY SIGNING IS IN PLACE PRIOR TO ALTERING ANY TRAFFIC PATTERN.

V) INSTALL BLACK ON ORANGE "DIP" SIGNS (W8-2) AND/OR "BUMP" SIGNS (W8-1) 61 M IN ADVANCE OF THE UNEVEN AREA, OR AS DIRECTED BY THE ENGINEER.

TRAFFIC BARRIER

W) INSTALL TEMPORARY BARRIER ACCORDING TO THE TRANSPORTATION MANAGEMENT PLANS A MAXIMUM OF TWO (2) WEEKS PRIOR TO BEGINNING WORK IN ANY LOCATION. ONCE TEMPORARY BARRIER IS INSTALLED AT ANY LOCATION PROCEED IN A CONTINUOUS MANNER TO COMPLETE THE PROPOSED WORK IN THAT LOCATION UNLESS OTHERWISE STATED IN THE TRANSPORTATION MANAGEMENT PLANS OR AS DIRECTED BY THE ENGINEER.

DO NOT PLACE BARRIER DIRECTLY ON ANY SURFACE OTHER THAN ASPHALT OR CONCRETE.

ONCE TEMPORARY BARRIER IS INSTALLED AT ANY LOCATION AND NO WORK IS PERFORMED BEHIND THE TEMPORARY BARRIER FOR A PERIOD LONGER THAN TWO (2) MONTHS, REMOVE / RESET TEMPORARY BARRIER AT NO COST TO THE DEPARTMENT UNLESS OTHERWISE STATED IN THE TRANSPORTATION MANAGEMENT PLANS, TEMPORARY BARRIER IS PROTECTING A HAZARD, OR AS DIRECTED BY THE ENGINEER.

INSTALL TEMPORARY BARRIER WITH THE TRAFFIC FLOW BEGINNING WITH THE UPSTREAM SIDE OF TRAFFIC. REMOVE TEMPORARY BARRIER AGAINST THE TRAFFIC FLOW BEGINNING WITH THE DOWNSTREAM SIDE OF TRAFFIC.

INSTALL AND SPACE DRUMS NO GREATER THAN TWICE THE POSTED SPEED LIMIT (MPH) TO CLOSE OR KEEP THE SECTION OF THE ROADWAY CLOSED UNTIL THE TEMPORARY BARRIER CAN BE PLACED OR AFTER THE TEMPORARY BARRIER IS REMOVED.

X) PROTECT THE APPROACH END OF MOVABLE/PORTABLE CONCRETE BARRIER AT ALL TIMES DURING THE INSTALLATION AND REMOVAL OF THE BARRIER BY EITHER A TRUCK MOUNTED ATTENUATOR (MAXIMUM 72 HOURS) OR A TEMPORARY CRASH CUSHION.

2/11/2015 10:41:11 AM C:\Users\Florence\Documents\TrafficControl\TCP\2413ca-tcp-general-notes-1b.dgn Florence & Hutchinson, Inc.

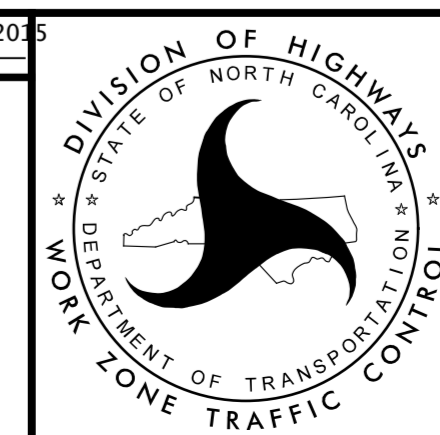
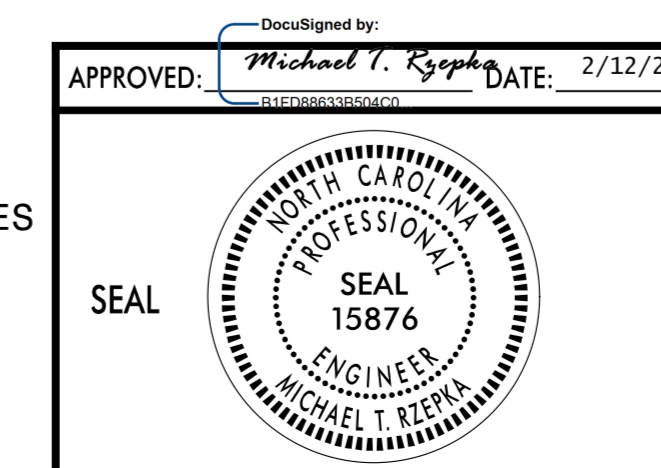

TRANSPORTATION OPERATIONS PLAN

GENERAL NOTES (CONT'D)

PROTECT THE APPROACH END OF MOVABLE/PORTABLE CONCRETE BARRIER FROM ONCOMING TRAFFIC AT ALL TIMES BY A TEMPORARY CRASH CUSHION UNLESS THE APPROACH END OF MOVABLE/PORTABLE CONCRETE BARRIER IS OFFSET FROM ONCOMING TRAFFIC AS FOLLOWS OR AS SHOWN IN THE PLANS: (SEE ALSO 1101.05)

POSTED SPEED LIMIT	MINIMUM OFFSET
40 OR LESS	4.5 M
45 - 50	6.1 M
55	7.6 M
60 MPH or HIGHER	9.1 M

TRAFFIC CONTROL DEVICES

- Y) WHEN LANE CLOSURES ARE NOT IN EFFECT SPACE CHANNELIZING DEVICES IN WORK AREAS NO GREATER IN FEET THAN TWICE THE POSTED SPEED LIMIT (MPH) EXCEPT, 3 M ON-CENTER IN RADII, AND .9 M OFF THE EDGE OF AN OPEN TRAVELWAY. REFER TO STANDARD SPECIFICATIONS FOR ROADS AND STRUCTURES SECTIONS 1130 (DRUMS), 1135 (CONES) AND 1180 (SKINNY DRUMS) FOR ADDITIONAL REQUIREMENTS.
- Z) PLACE TYPE III BARRICADES, WITH "ROAD CLOSED" SIGN R11-2 ATTACHED, OF SUFFICIENT LENGTH TO CLOSE ENTIRE ROADWAY.

PAVEMENT MARKINGS AND MARKERS

- AA) INSTALL TEMPORARY PAVEMENT MARKINGS AND TEMPORARY PAVEMENT MARKERS ON INTERIM LAYERS OF PAVEMENT AS FOLLOWS:

ROAD NAME	MARKING	MARKER
ALL ROADS	PAINT	TEMPORARY RAISED

- BB) PLACE ONE APPLICATION OF PAINT FOR TEMPORARY TRAFFIC PATTERNS. PLACE A SECOND APPLICATION OF PAINT SIX (6) MONTHS AFTER THE INITIAL APPLICATION AND EVERY SIX MONTHS AS DIRECTED BY THE ENGINEER.
- CC) TIE PROPOSED PAVEMENT MARKING LINES TO EXISTING PAVEMENT MARKING LINES.
- DD) REMOVE/REPLACE ANY CONFLICTING/DAMAGED PAVEMENT MARKINGS AND MARKERS BY THE END OF EACH DAY'S OPERATION.
- EE) TRACE THE PROPOSED MONOLITHIC ISLAND LOCATIONS WITH PROPER COLOR PAVEMENT MARKINGS PRIOR TO INSTALLATION. PLACE DRUMS TO DELINEATE ANY PROPOSED MONOLITHIC ISLANDS BEFORE INSTALLATION.

MISCELLANEOUS

- FF) LAW ENFORCEMENT MAY BE USED TO MAINTAIN TRAFFIC THROUGH THE WORK AREA AND/OR INTERSECTIONS AS DIRECTED BY THE ENGINEER.

LOCAL NOTES

- 1) COORDINATE WITH ADJACENT PROJECT, R-2413C, FOR CONSTRUCTION ACTIVITIES AND TRAFFIC SHIFTS THAT CROSS PROJECT LIMITS.
- 2) WHEN USING GENERAL NOTE 'C' TO CLOSE NC 68 FOR STRUCTURE WORK IN PHASE II, STEP 1, USE RSD 1101.02 (SHEET 3 OF 15) TO CLOSE THE RIGHT LANE ON SB US 220/NC 68 PRIOR TO THE NC 68 EXIT. PLACE TEMPORARY SIGNAL AT US 220/NC 68 INTERSECTION IN FLASH MODE DURING CLOSURE.

MANAGEMENT STRATEGY

THE FOLLOWING LISTED STRATEGIES DERIVE FROM DETAILED DESIGN LEVEL ASSESSMENTS OF THE WORK ZONE IMPACTS CONDUCTED DURING THE DEVELOPMENTAL STAGES OF THIS TRANSPORTATION MANAGEMENT PLAN (TMP).

RECOMMENDED MANAGEMENT STRATEGIES RELATIVE TO THIS TMP ARE AS FOLLOWS:

-ONE-LANE TWO-WAY TRAFFIC:

TRAFFIC TO BE MAINTAINED ON US 220 (EXISTING TWO-LANE/TWO-WAY SECTION), UTILIZING FLAGGERS AS NECESSARY.

-ONE LANE IN EACH DIRECTION TRAFFIC:

TRAFFIC TO BE MAINTAINED ON US 220 AND NC 68 (EXISTING 4-LANE DIVIDED SECTION), UTILIZING LANE CLOSURES IN EACH DIRECTION AS NECESSARY.

-FULL ROAD CLOSURES:

TRAFFIC ON NC 68 TO BE MAINTAINED ON THE FOLLOWING OFF-SITE DETOUR DURING THE INTERMEDIATE CONTRACT TIME FOR GIRDER PLACEMENT:

DETOUR: NC 68 TO NC 65 TO US 220 TO US 220/NC 68

-TEMPORARY ROAD CLOSURES/STOP TRAFFIC (30 MIN.)

ON US 220 AND NC 68 FOR TIE-INS AND TRAFFIC SHIFTS.

-COORDINATION BETWEEN R-2413CA AND ADJACENT R-2413C

COORDINATE WITH ADJACENT R-2413C TO ASSURE THAT TRAFFIC SHIFTS ARE CONTINUOUS ACROSS PROJECT LIMITS.



PROJ. REFERENCE NO.	SHEET NO.
R-2413CA	TMP-1C

2/11/2015
R:\Traffic\TrafficControl\TCP\2413ca_tcp_gennotes_lc.dgn
Florence & Hutchison, Inc.

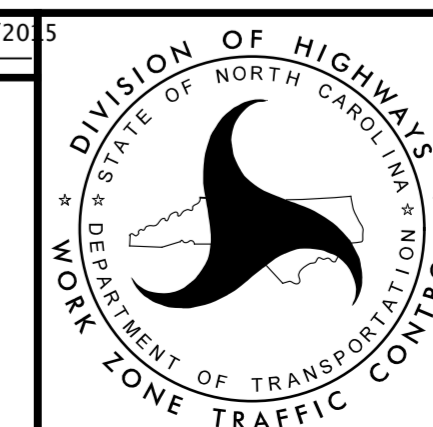
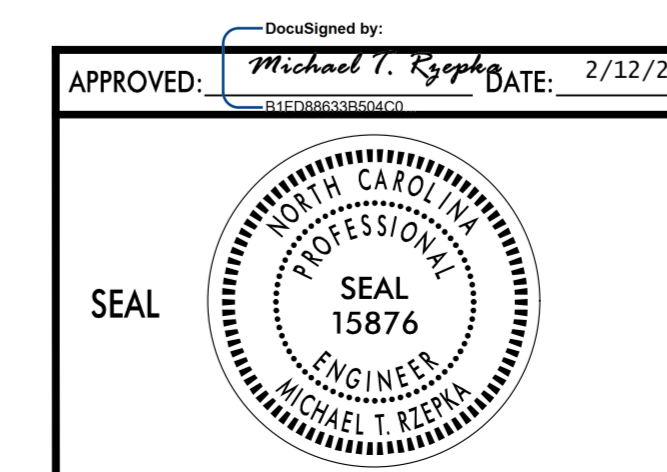

TRANSPORTATION
OPERATIONS PLAN

MESSAGE NO. 1	MESSAGE NO. 2
NC 68 CLOSED AT US220	DETOUR FOLLOW US 220

CHANGEABLE MESSAGE SIGN

INSET

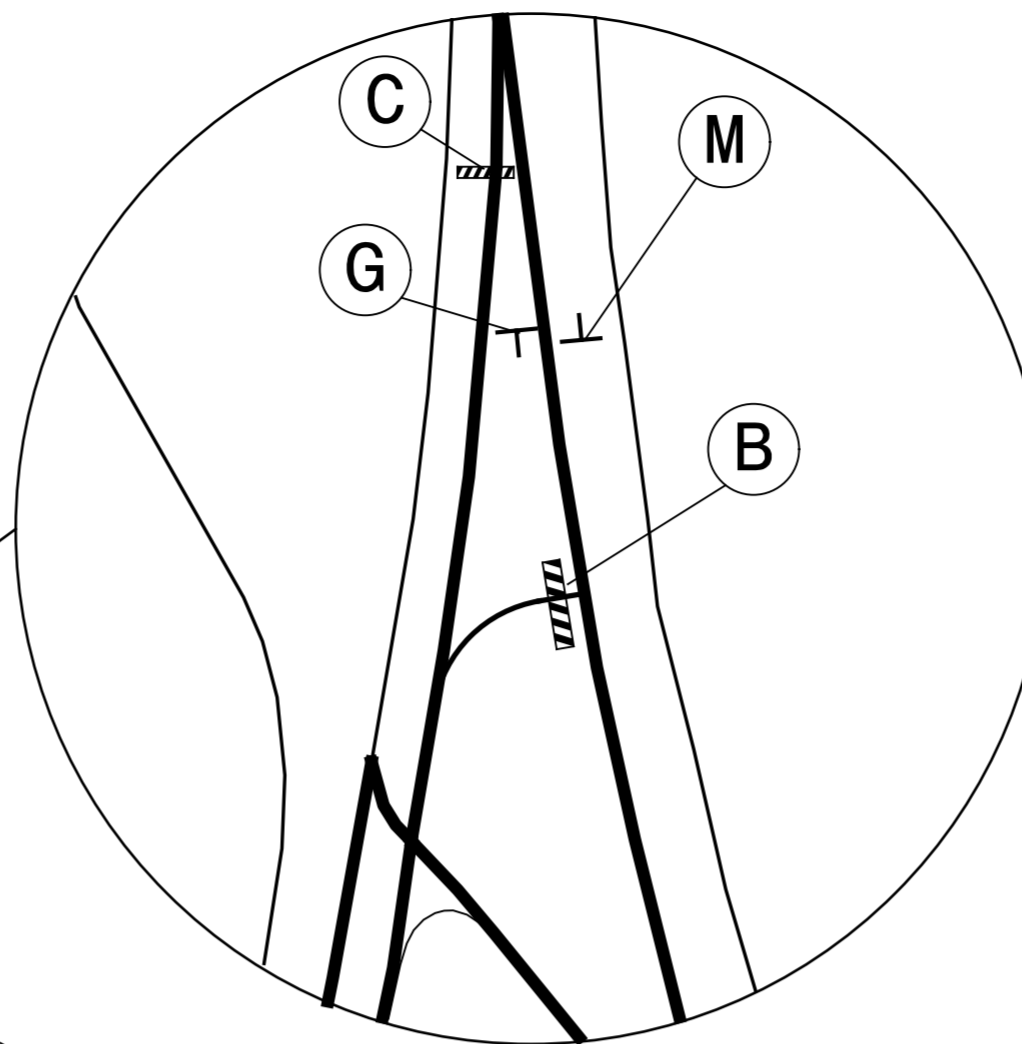

PROJ. REFERENCE NO.	SHEET NO.
R-2413CA	TMP-2A

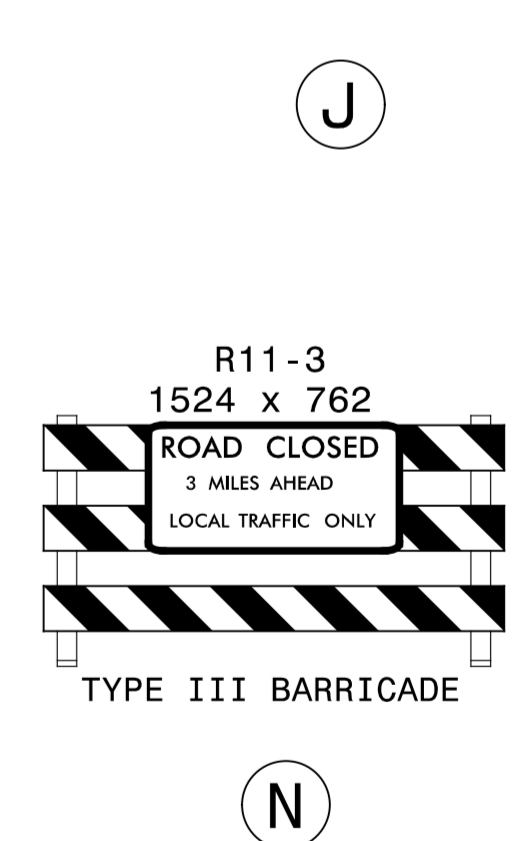
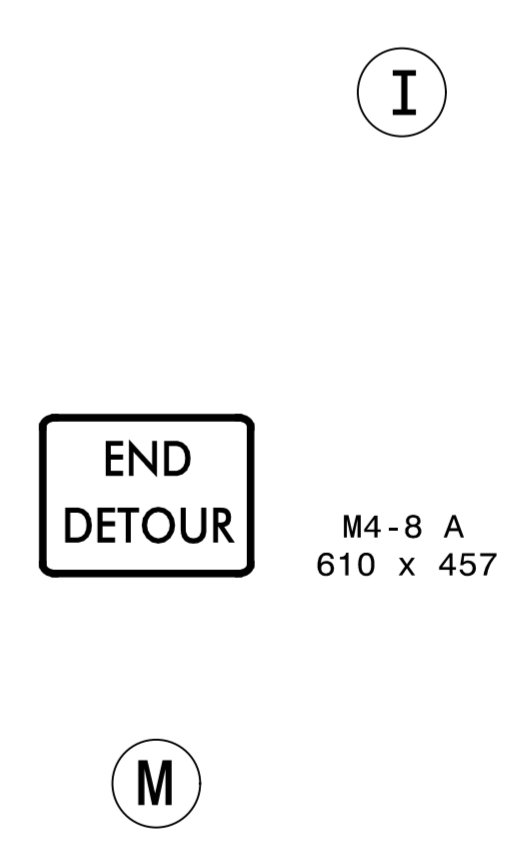
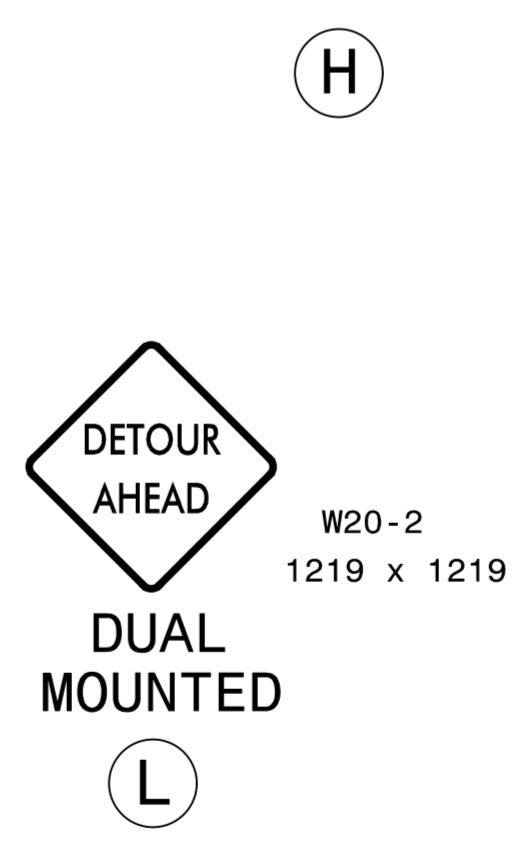
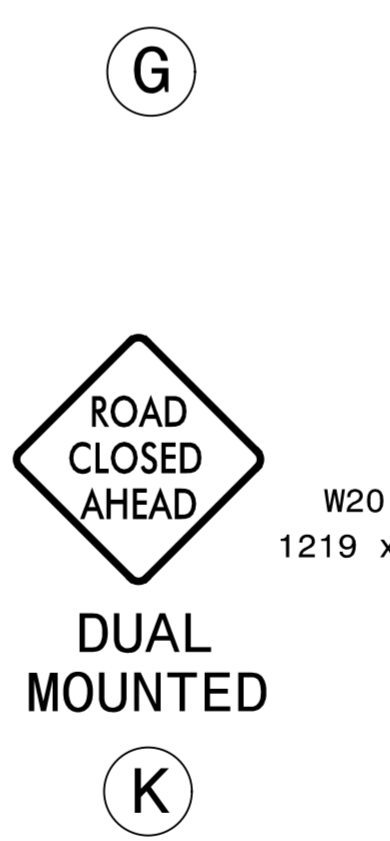
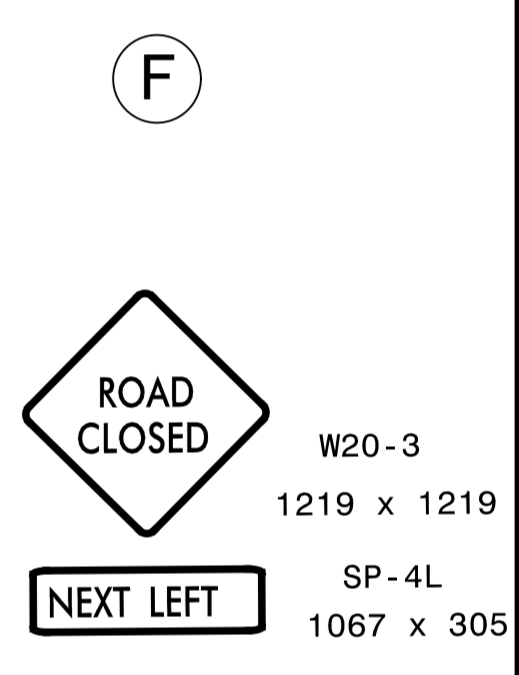
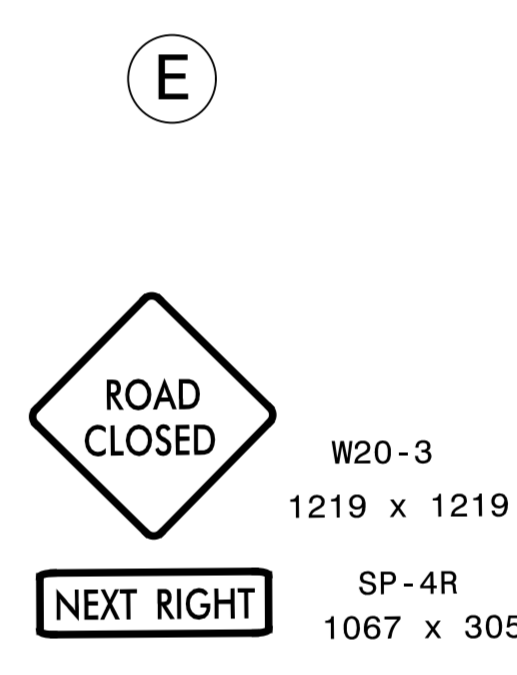
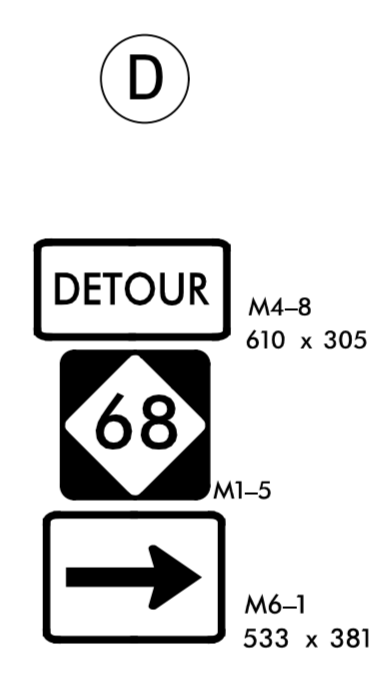
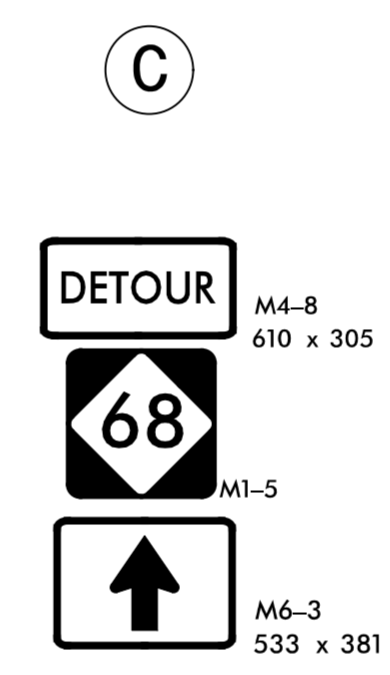
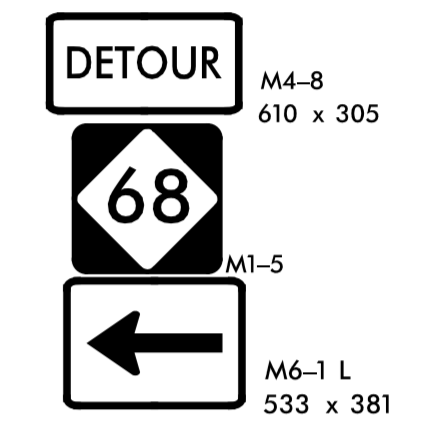
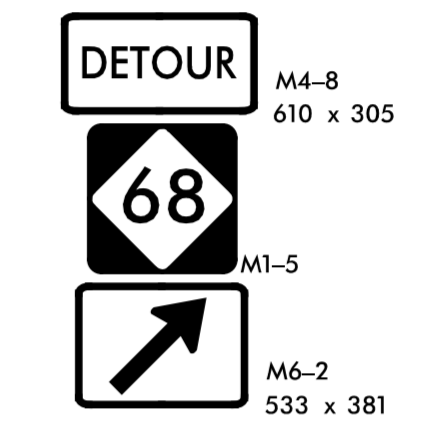
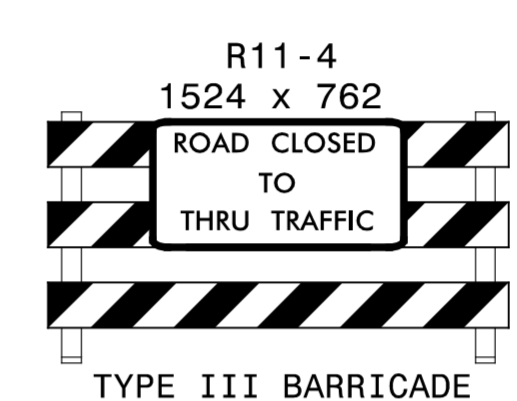
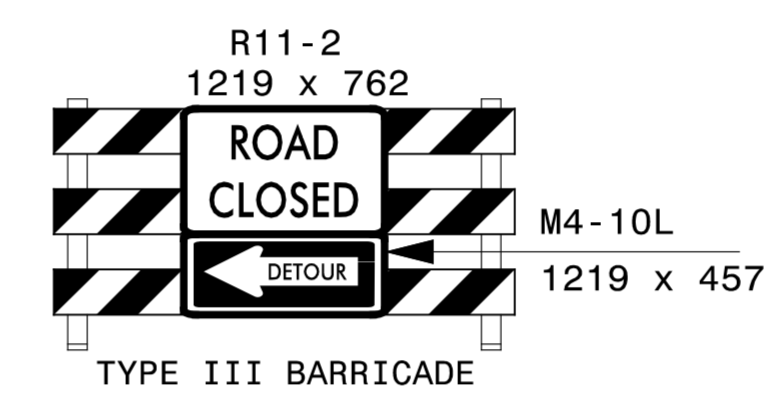
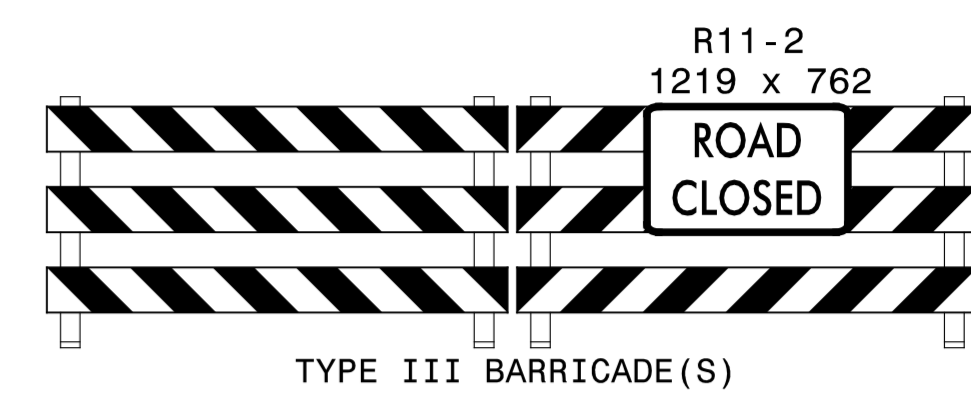
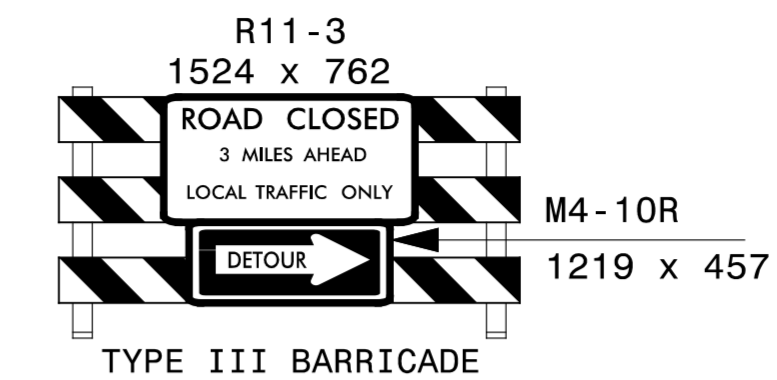
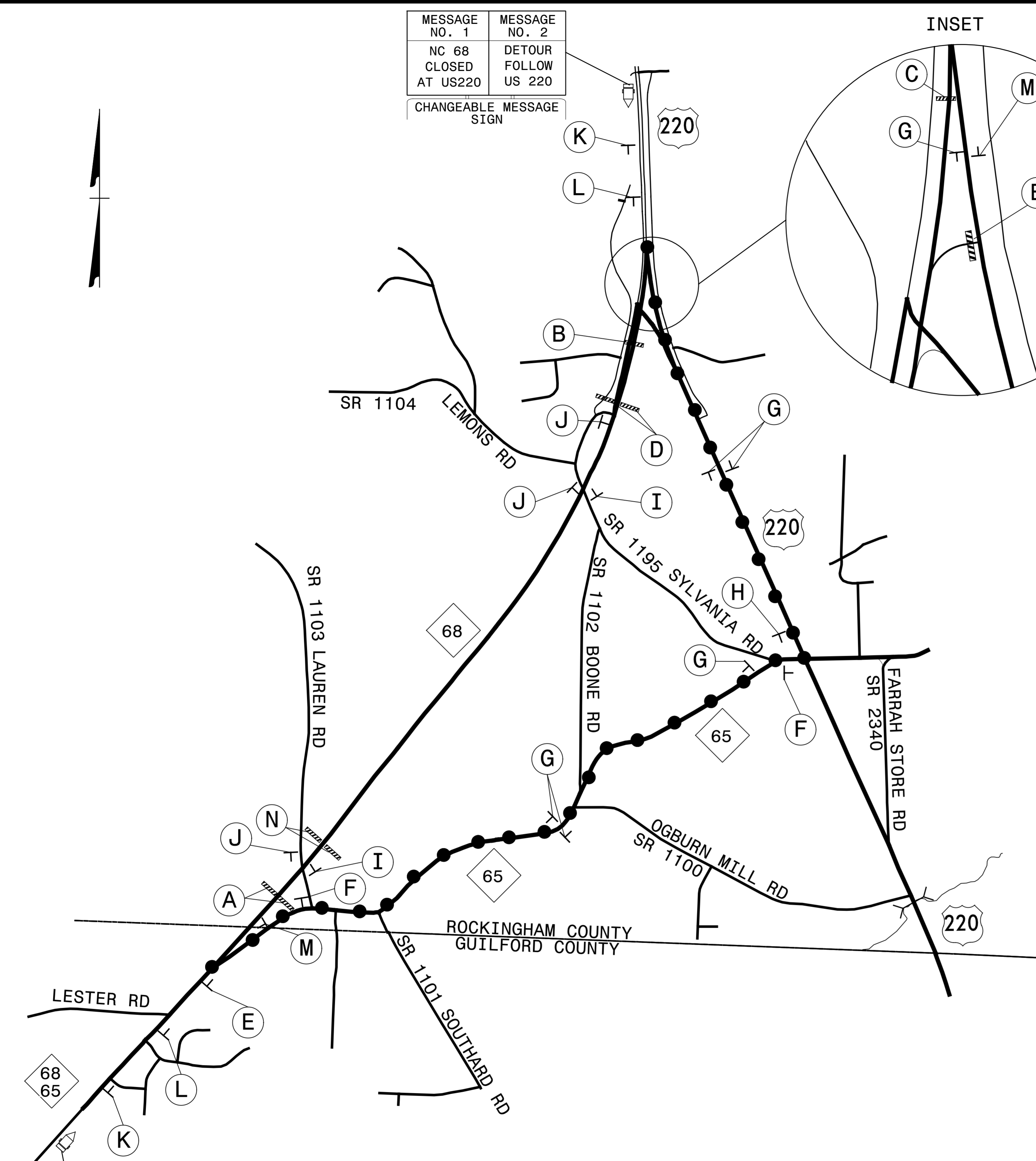
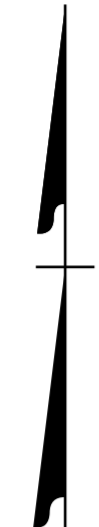

MESSAGE NO. 1	MESSAGE NO. 2
NC 68 CLOSED AT US220	THRU TRAF USE NC 65

CHANGEABLE MESSAGE SIGN

LEGEND

- DETOUR ROUTES
- ▨▨▨▨ TYPE III BARRICADE
- ┤ POST MOUNTED SIGN

APPROVED: *Michael T. Rzepka* DATE: 2/12/2015

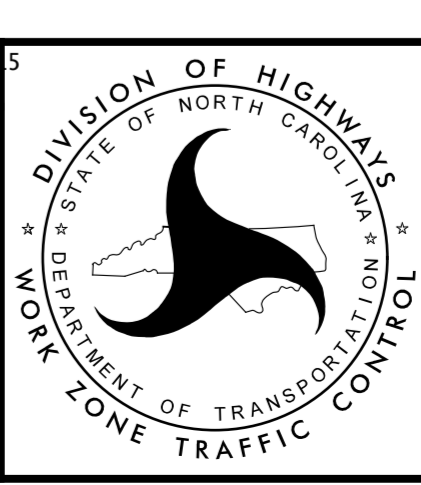

**NC 68
DETOUR ROUTE**

2/11/2015 R:\Traffic\TrafficControl\TCP\2413ca_tcp_detour_nc68.dgn Florence & Hutchison, Inc.



PHASING

PHASE I

NOTES:

- "RSD" REFERS TO NCDOT ROADWAY STANDARD DRAWINGS
- "PCB" REFERS TO PORTABLE CONCRETE BARRIER
- ALL PROPOSED ASPHALT CONSTRUCTION IN PHASE I THROUGH PHASE III IS UP TO BUT NOT INCLUDING THE FINAL LAYER OF SURFACE COURSE.

STEP 1

USING ROADWAY STANDARD DRAWING NO. 1101.01, SHEETS 2 & 3 OF 3, INSTALL ALL WORK ZONE ADVANCE WARNING SIGNS ON US 220, NC 68 AND AFFECTED -Y- LINES.

STEP 2

AWAY FROM TRAFFIC, BEGIN CONSTRUCTION OF THE FOLLOWING PROPOSED (SEE SHEETS TMP-4, 5, 7 & 8):

- L REV- STA 84+00± TO -LREV SB- STA 86+18± (SB LANES)
- LREV SB- STA 86+18± TO STA 87+00±
- LREV SB- STA 91+80± TO STA 96+60±
- NC68 SB- STA 13+60± TO STA 15+79±

USING RSD 1101.02 (SHEET 3 OF 15), BEGIN CONSTRUCTION OF THE FOLLOWING TEMPORARY PAVEMENT/TEMPORARY WIDENING (SEE SHEETS TMP-6 THRU 9):

- NC68SB DET- FROM -NC68 MED- STA 9+23± TO -NC68 NB- STA 12+25±
- NC68SB DET- FROM -NC68 NB- STA 14+00± TO -LREV NB- STA 93+26±
- LREV NB- STA 87+65± TO STA 92+94±, LEFT OF EXISTING NB US 220
- LREV NB- STA 93+26± TO STA 97+14±, LEFT OF EXISTING NB US 220
- LREVEN XOVR- FROM -LREV NB- STA 97+14± TO -LREV END- STA 100+76±

USING RSD 1101.02 (SHEET 9 OF 15), CONSTRUCT TEMPORARY PAVEMENT/TEMPORARY WIDENING AT -NC68SB DET- FROM -NC68 NB- STA 12+43± TO -NC68 NB- STA 14+00± (LEFT OF EXISTING NB NC 68)(SEE SHEETS TMP-6 & 7).

USING RSD 1101.02 (SHEET 9 OF 15), BEGIN INSTALLATION OF TEMPORARY SIGNAL FOR PHASE II PATTERN AT -LREV NB- & -NC68NB DET- INTERSECTION AND KEEP DEACTIVATED.

STEP 3

USING RSD 1101.02 (SHEET 9 OF 15), PLACE TEMPORARY PAVEMENT MARKINGS (WHITE EDGLINE) TO NARROW EXISTING NB NC 68 AT PROPOSED STRUCTURE AND INSTALL PCB ALONG WHITE EDGLINE. CONSTRUCT PROPOSED -LREV SB- END BENT #1, INCLUDING MSE WALL AND SLOPE PROTECTION RIGHT OF -NC68 NB- (SEE SHEETS TMP-10 & 11).

BEHIND BARRIER, CONSTRUCT THE FOLLOWING (SEE SHEETS TMP-10 & 11):

- NC68NB DET- FROM -NC68 NB- STA 12+30± TO STA 13+39±
- NC68NB DET- FROM -NC68 NB- STA 13+39± TO EXISTING NB US 220±

COMPLETE CONSTRUCTION OF THE FOLLOWING BEGUN IN PHASE I, STEP 2:

- NC68SB DET- FROM -NC68 MED- STA 9+23± TO -NC68 NB- STA 12+25±
 - NC68SB DET- FROM -NC68 NB- STA 14+00± TO -LREV NB- STA 93+26±
 - LREV NB- STA 87+65± TO STA 92+94±, LEFT OF EXISTING NB US 220
 - LREV NB- STA 93+26± TO STA 97+14±, LEFT OF EXISTING NB US 220
 - LREVEN XOVR- FROM -LREV NB- STA 97+14± TO -LREV END- STA 100+76±
- INSTALLATION OF TEMPORARY SIGNAL FOR PHASE II PATTERN AT -LREV NB- & -NC68NB DET- INTERSECTION

PHASE II

STEP 1

USING RSD 1101.02 (SHEET 3 & 9 OF 15), PLACE TEMPORARY PAVEMENT MARKINGS AND MARKERS, REMOVE CONFLICTING PCB AND INSTALL PCB AS SHOWN FOR PHASE II, STEP 1 TRAFFIC PATTERNS AND SHIFT TRAFFIC TO THE FOLLOWING TEMPORARY PATTERNS FOR NC 68 & US 220 (SEE SHEETS TMP-12 THRU 16):

- NC68NB DET- FOR NB NC 68 TRAFFIC
- NC68SB DET- FOR SB NC 68 TRAFFIC
- NB US 220 LEFT SIDE WIDENING AND -LREVEN XOVR- FOR SB US 220 TRAFFIC
- ACTIVATE TEMPORARY SIGNAL AT US 220 AND -NC68NB DET- INTERSECTION.
- CLOSE EXISTING ACCESS FROM NC 68 TO SB US 220.

USING RSD 1101.02 (SHEET 1, 3 & 9 OF 15) AND BEHIND BARRIER, BEGIN CONSTRUCTION OF THE FOLLOWING (SEE SHEETS TMP-12 THRU 17)(SEE GENERAL NOTE 'C' AND LOCAL NOTE 2 FOR STRUCTURE WORK INVOLVING ROAD CLOSURE AND SHEET TMP-2A FOR NC 68 DETOUR ROUTE):



- L REV SB- STA 87+00± TO STA 90+00±
- NC68 SB- STA 10+00± TO STA 13+60±
- L REV SB- STRUCTURE, INCLUDING END BENT #2, MSE WALL AND SLOPE PROTECTION
- L REV SB- FROM PROPOSED STRUCTURE TO -L REV SB- STA 91+80±
- L REV SB- STA 96+60± TO STA 98+72±
- LREV END- STA 98+41± TO STA 105+65± (WIDENING OF EXISTING SB US 220)

STEP 2

COMPLETE CONSTRUCTION BEGUN PHASES I & II:

- L REV- STA 84+00± TO -LREV SB- STA 86+18± (SB LANES)
- LREV SB- STA 86+18± TO STA 90+00±
- NC68 SB- STA 10+00± TO STA 13+60±
- L REV SB- STRUCTURE, INCLUDING END BENT #2, MSE WALL AND SLOPE PROTECTION
- L REV SB- FROM PROPOSED STRUCTURE TO -L REV SB- STA 91+80±
- L REV SB- STA 96+60± TO STA 98+72±
- LREV END- STA 98+41± TO STA 105+65± (WIDENING OF EXISTING SB US 220)

2/11/2015 R:\Traffic\TrafficControl\TCP\2413ca_tcp_phasing_i&ii.dgn Florence & Hutcheson, Inc.

<p>DocuSigned by: <i>Michael I. Kyepeh</i> DATE: 2/12/2015</p> <p>APPROVED: _____ DATE: _____</p>		
PHASES I & II PHASING		



PHASING

PHASE III

NOTE: - COMPLETE THE WORK REQUIRED OF PHASE III, STEPS 1A & 1B IN A CONTINUOUS MANNER.
 - COORDINATE WITH R-2413C TO SHIFT TRAFFIC TO PROPOSED US 220 SB LANES.

STEP 1A

USING RSD 1101.02 (SHEET 3 OF 15) ON SB US 220, CONSTRUCT CROSSOVER -LREVSX XOVR- FROM -LREV SB- STA 97+88± TO -LREV END- STA 100+73± (SEE SHEETS TMP-19 THRU 20).

STEP 1B

USING RSD 1101.02 (SHEET 1 & 3 OF 15), PLACE TEMPORARY PAVEMENT MARKINGS AND MARKERS, REMOVE CONFLICTING PCB AND INSTALL PCB AS SHOWN FOR PHASE III, STEP 1 TRAFFIC PATTERNS AND SIMULTANEOUSLY SHIFT TRAFFIC TO THE FOLLOWING TEMPORARY PATTERNS (SEE LOCAL NOTE 1):

- FOR US 220 (2-LANE/2-WAY) (SEE SHEETS TMP-24 THRU 28):
 - L REV- STA 84+00± TO STA 86+18± (SB LANES)
 - LREV SB- STA 86+18± TO STA 98+19±
 - LREVSX XOVR- (MEDIAN CROSSOVER -LREVSX XOVR- STA 97+88± TO -LREV END- STA 100+76±)

- NC 68 ACCESS TO US 220 (2-LANE/2-WAY) (SEE SHEETS TMP-25 & 26):
 - NC68 SB- STA 10+00± TO SB -LREV SB-
 - NB NC 68 ACCESS TO US 220 REMAINS IN PHASE II PATTERN (-NC68NB DET-)

CLOSE EXISTING ACCESS FROM BENNETT FARM ROAD TO EXISTING US 220 NEAR -LREV- STA 84+00± (SEE SHEET TMP-18).

STEP 2

USING RSD 1101.02 (SHEETS 1, 3 & 9 OF 15), BEGIN ITS CONSTRUCTION (SEE ITS PLANS AND INTELLIGENT TRANSPORTATION SYSTEMS PROJECT SPECIAL PROVISIONS).

AWAY FROM TRAFFIC, BEGIN PROPOSED CONSTRUCTION AT THE FOLLOWING LOCATIONS (SEE SHEETS TMP-21 THRU 25):

- L REV- STA 75+60± TO 86+18± (NB LANES)
- LREV NB- STA 86+18± TO STA 90+09±

USING RSD 1101.02 (SHEET 9 & 10 OF 15) AND AWAY FROM TRAFFIC, CONSTRUCT WEDGING AND WIDENING FROM -NC68 NB- STA 10+00± TO STA 16+00± AND TIE TO EXISTING NB US 220. WEDGE NB US 220 FROM -LREV NB- STA 92+45± TO STA 96+00± (SEE SHEETS TMP-25 THRU 27).

AWAY FROM TRAFFIC BEGIN REMOVAL OF TEMPORARY AND ABANDONED EXISTING PAVEMENTS.

STEP 3

USING RSD 1101.02 (SHEET 9 & 10 OF 15), PLACE TEMPORARY PAVEMENT MARKINGS AND SHIFT NB NC 68 TRAFFIC FROM -NC68NB DET- TO -NC68 NB- (SEE SHEETS TMP-30 THRU 33).

USING RSD 1101.02 (SHEET 9 OF 15), CONSTRUCT WEDGING AND WIDENING OF EXISTING NB US 220 AT THE FOLLOWING LOCATIONS (SEE SHEETS TMP-29 THRU 33):

- LREV NB- STA 90+09± TO STA 92+45±, RT (WEDGING & WIDENING)
- LREV NB- STA 92+45± TO STA 96+00±, RT (WIDENING ONLY)
- LREV NB- STA 96+00± TO STA 98+39±, RT (WEDGING & WIDENING)
- LREV END- STA 98+41± TO STA 105+65±, RT (WEDGING & WIDENING)

PHASE IV

NOTE: COORDINATE WITH R-2413C TO SHIFT NORTHBOUND TRAFFIC TO PROPOSED NB US 220 LANES IN PHASE IV (SEE LOCAL NOTE 1).

STEP 1

COMPLETE REMAINING CONSTRUCTION BEGUN IN PHASE III.

COMPLETE ITS CONSTRUCTION.

STEP 2

USING RSD 1101.02 (SHEET 1 OF 9), IN ONE CONTINUOUS OPERATION, SHIFT NB US 220 TRAFFIC INTO THE PROPOSED NORTHBOUND LANES FROM -L REV- STA 75+60± TO -LREV END- STA 105+65±.

STEP 3

USING RSD 1101.02 (SHEET 3 OF 15), COMPLETE CONSTRUCTION OF -L- MEDIAN CURB AND GUTTER, DRAINAGE, CONCRETE ISLANDS AND MEDIAN FROM NORTH OF NC 68 INTERCHANGE TO -LREV END- STA 105+65± (SEE SHEET TMP-34).

USING RSD 1101.02 (SHEET 3 OF 15), COMPLETE REMOVAL OF TEMPORARY AND ABANDONED EXISTING PAVEMENTS BEGUN IN PHASE III (SEE SHEET TMP-34).

STEP 4



USING RSD 1101.02 (SHEET 3 OF 15), PLACE THE FINAL LAYER OF SURFACE COURSE ON -L- LINE AND ALL -Y- LINES FINAL PAVEMENT MARKINGS AND MARKERS. OPEN ALL LANES TO TRAFFIC.

STEP 5

REMOVE ALL TRAFFIC CONTROL DEVICES.

6-12-2014 REVISED PHASING IN US 220/NC 68 AREA

2/11/2015 R:\TrafficControl\TCP\2413ca_tcp_phasing_iii&iv.dgn Florence & Hutcheson, Inc.

APPROVED: 	DocuSigned by: <i>Michael I. Rzepka</i> DATE: 2/12/2015 	PHASES III & IV PHASING
---	---	------------------------------------

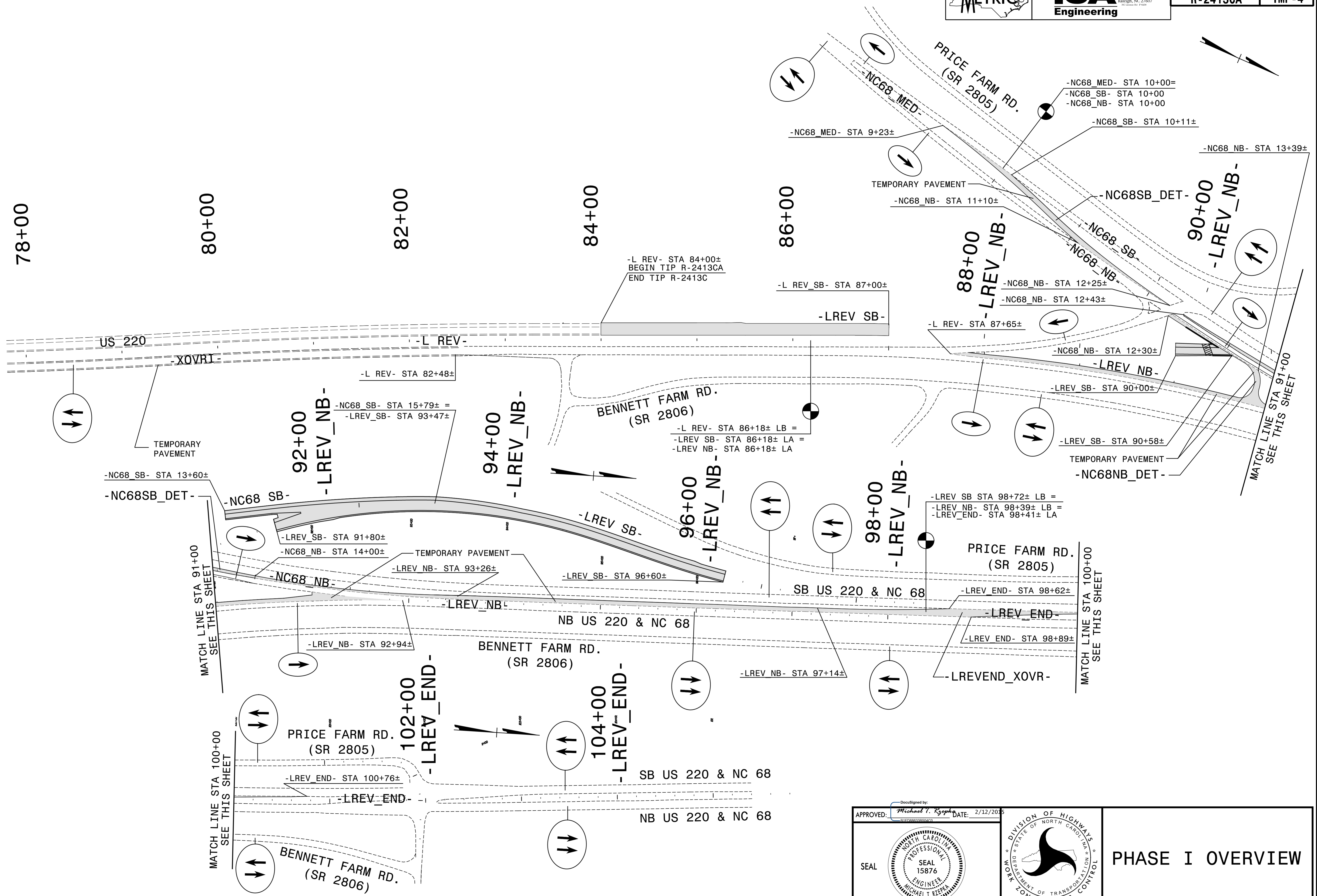

2/11/2015
 R:\Trat\Fig1\Trat\FigCont\Tol\TCPV\2413ca_tcp_pi_oww_e.dgn
 Florence & Hutchison, Inc.

APPROVED: *Michael T. Ryzko* DATE: 2/12/2015

DocuSigned by:
Michael T. Ryzko

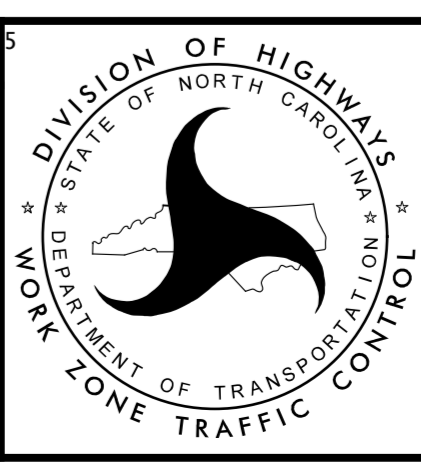

PHASE I OVERVIEW



PROJ. REFERENCE NO.	SHEET NO.
R-2413CA	TMP-5

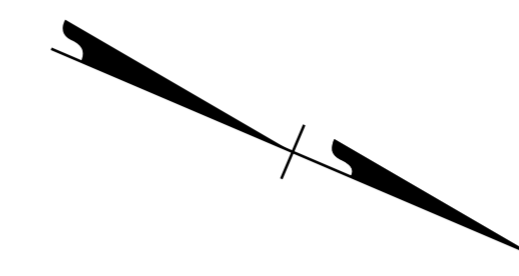

84+00

85+00

86+00

BEGIN TIP R-2413CA
 -L REV- STA 84+00±

-L REV- STA 87+00±

PROP. SB LANES

-LREV_SB-

-L REV-

US 220

-LREV_NB-

SR 2806 BENNETT FARM RD

-L REV- STA 86+18± LB =
 -LREV SB- STA 86+18± LA =
 -LREV NB- STA 86+18± LA

MATCH LINE
 SEE SHEET TMP-6

2/11/2015
 R:\Traffic\TrafficControl\TCP\2413ca_tcp_pi_s2_dtl_21.dgn
 Florence & Hutchison, Inc.

APPROVED: *Michael T. Rzepka* DATE: 2/12/2015

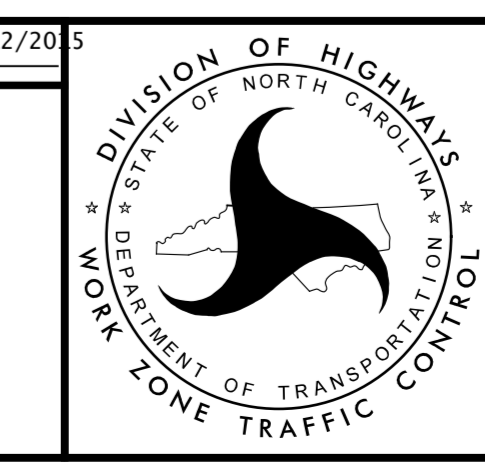
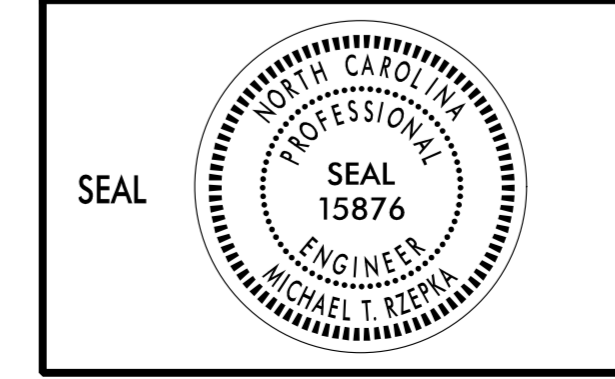

PHASE I, STEP 2
 DETAIL

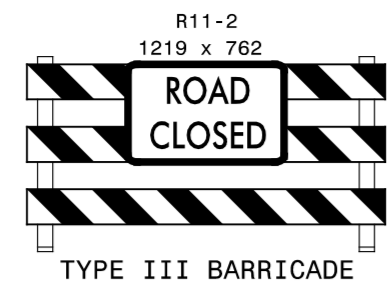

1

MATCH LINE
SEE THIS SHEET

-NC68_MED- STA 10+00=
-NC68_SB- STA 10+00
-NC68_NB- STA 10+00

-NC68_SB- STA 10+11±

SR 2805 PRICE FARM RD

-NC68SB DET-
TEMP. PAVEMENT

NC 68 SBL

NC 68 NBL

-NC68_NB- STA 11+10±

-NC68_MED- STA 9+23±

-NC68_MED-

-NC68_NB-

NC 68 SBL

NC 68 NBL

-NC68_SB-

-NC68SB DET-
TEMP. PAVEMENT

-NC68_NB- STA 12+25±

-NC68SB DET-
TEMP. PAVEMENT

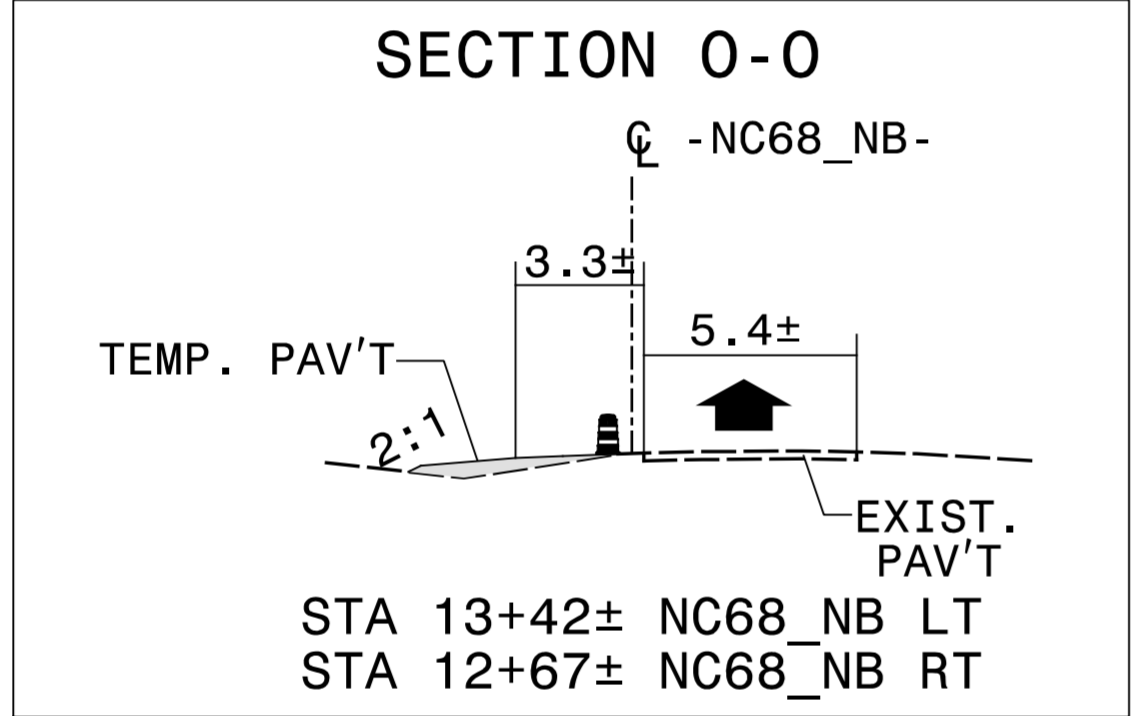

MATCH LINE
SEE THIS SHEET

88+00

89+00

90+00

-L REV- STA 87+65±
BEGIN TEMP. WIDENING

-LREV_SB-

-NC68_NB- STA 12+43±

TEMP. PAVEMENT

-LREV_NB-

US 220

9.0

MATCH LINE
SEE SHEET TMP-7

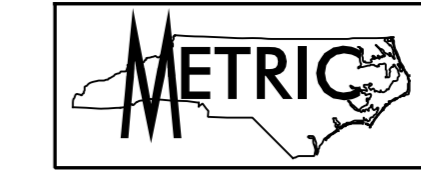

PROJ. REFERENCE NO.	SHEET NO.
R-2413CA	TMP-6

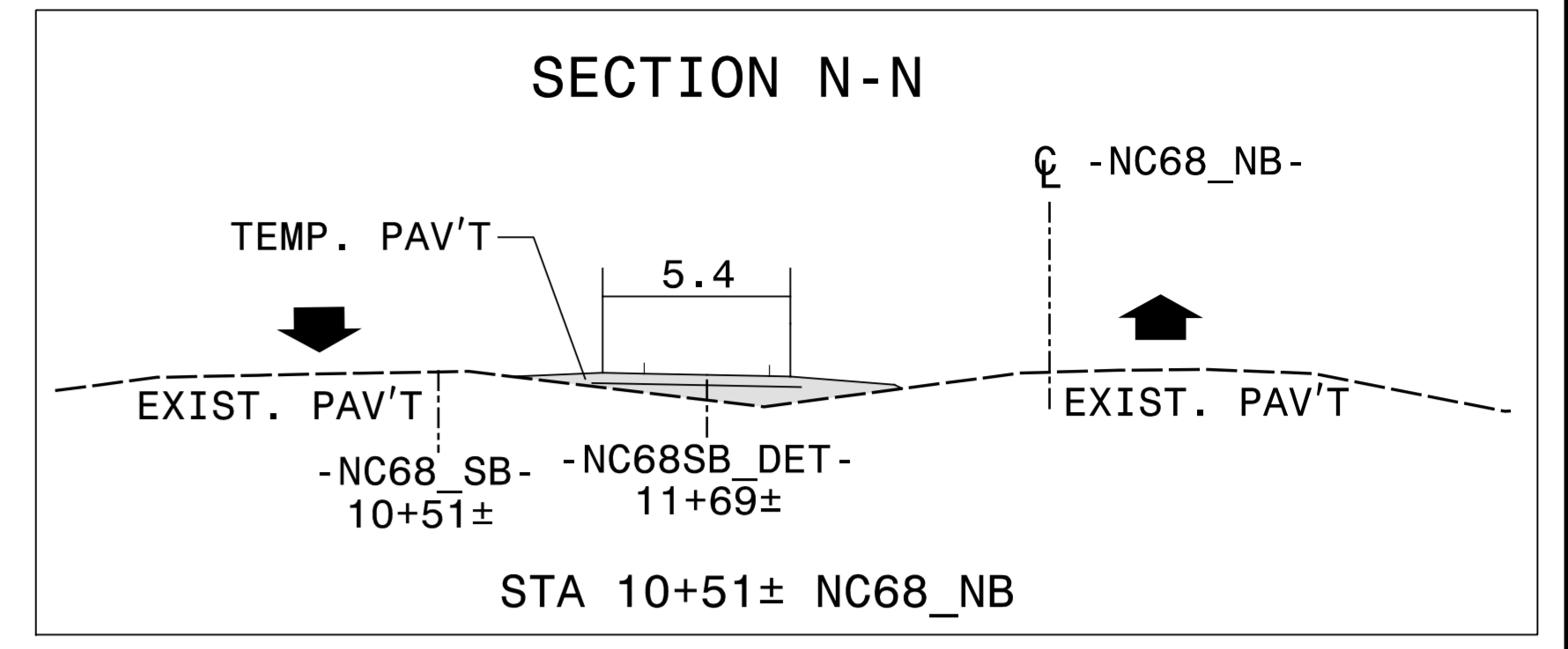

MATCH LINE
SEE SHEET TMP-5

SR 2806 BENNETT FARM RD

APPROVED: Michael T. Rzepka DATE: 2/12/2015

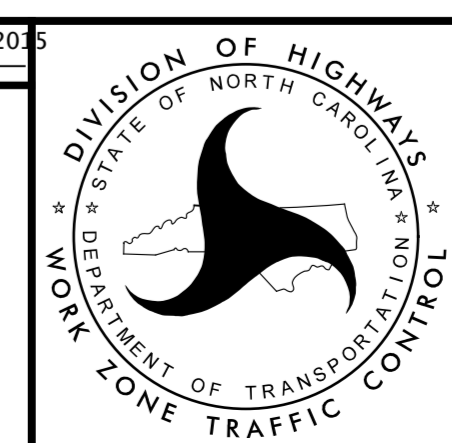
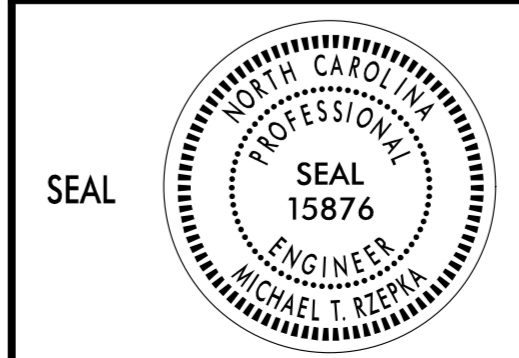

PHASE I, STEP 2
DETAIL

2/11/2015 10:17:41 AM R:\TrafficControl\CPV\2413ca_tcp_pi_s2_dtl_22.dgn Florence & Hutchison, Inc.

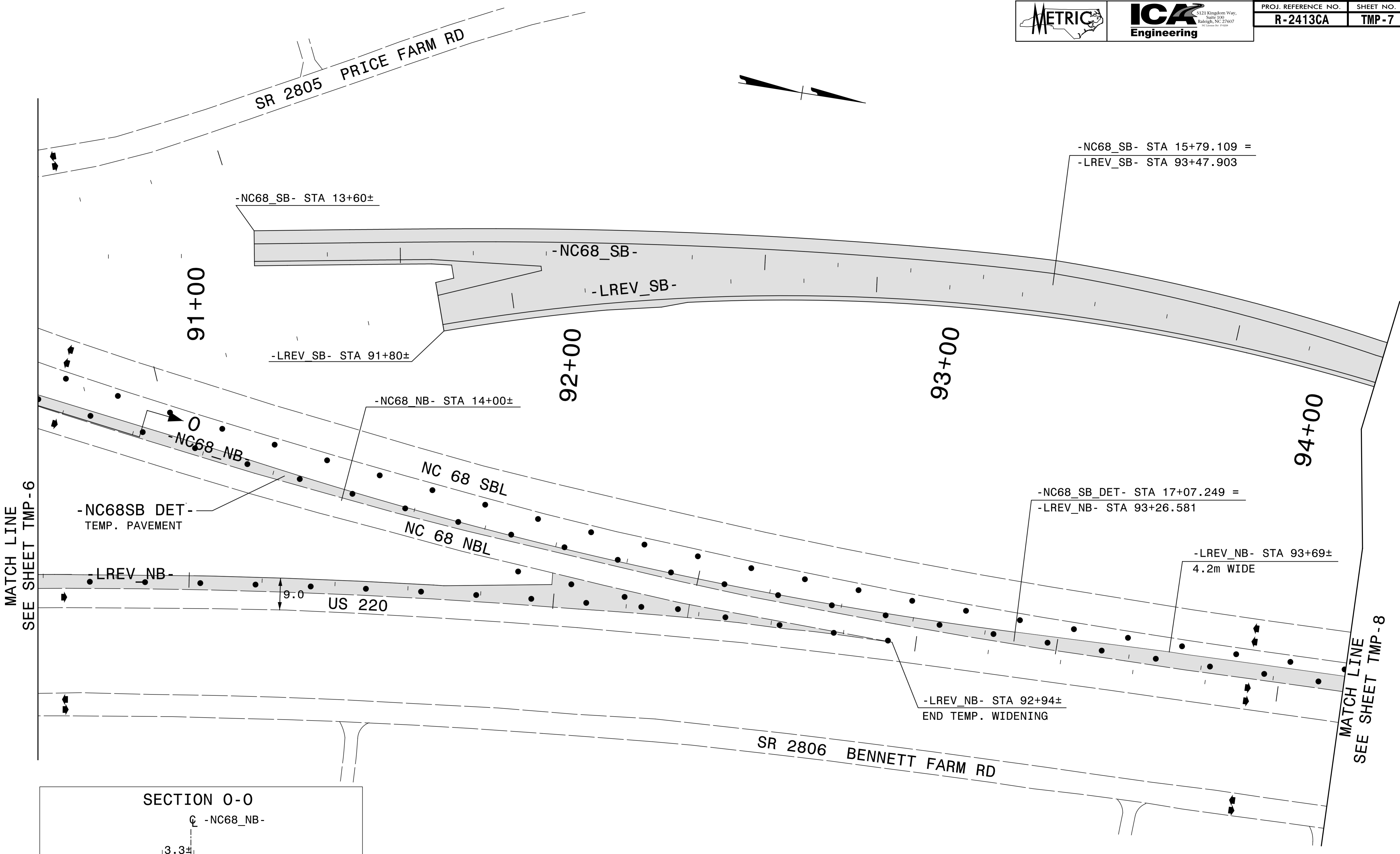

MATCH LINE
SEE SHEET TMP-6

MATCH LINE
SEE SHEET TMP-8

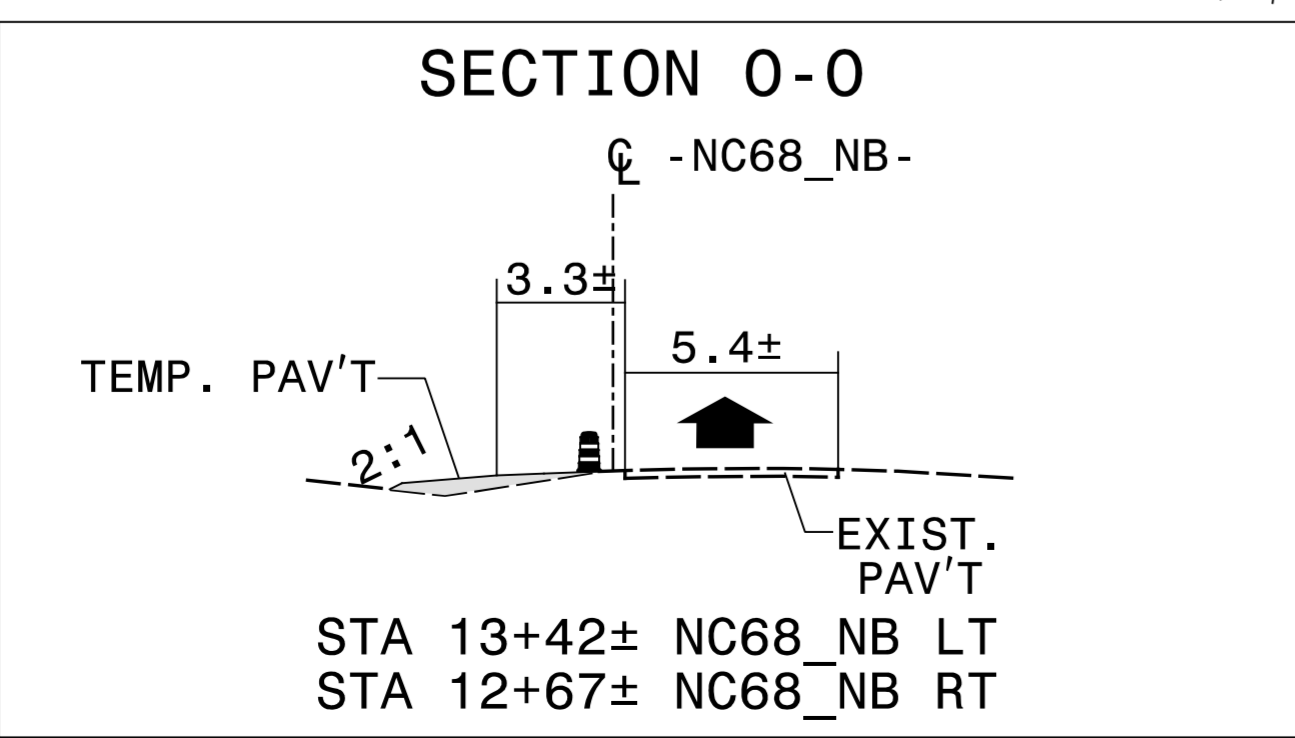

APPROVED: *Michael T. Rzepka* DATE: 2/12/2015

DocuSigned by:
Michael T. Rzepka

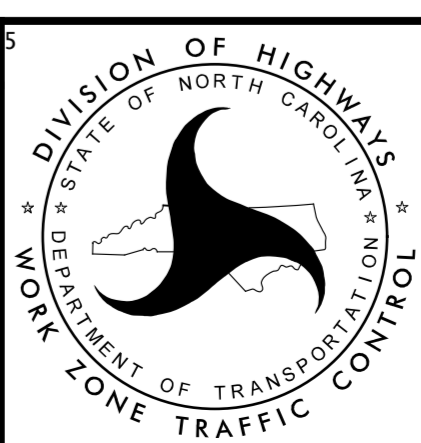

**PHASE I, STEP 2
DETAIL**

2/11/2015
E:\TrafficControl\CPV\2413ca_tcp.plt_s2.dtl_23.dgn
Florence & Hutchison, Inc.

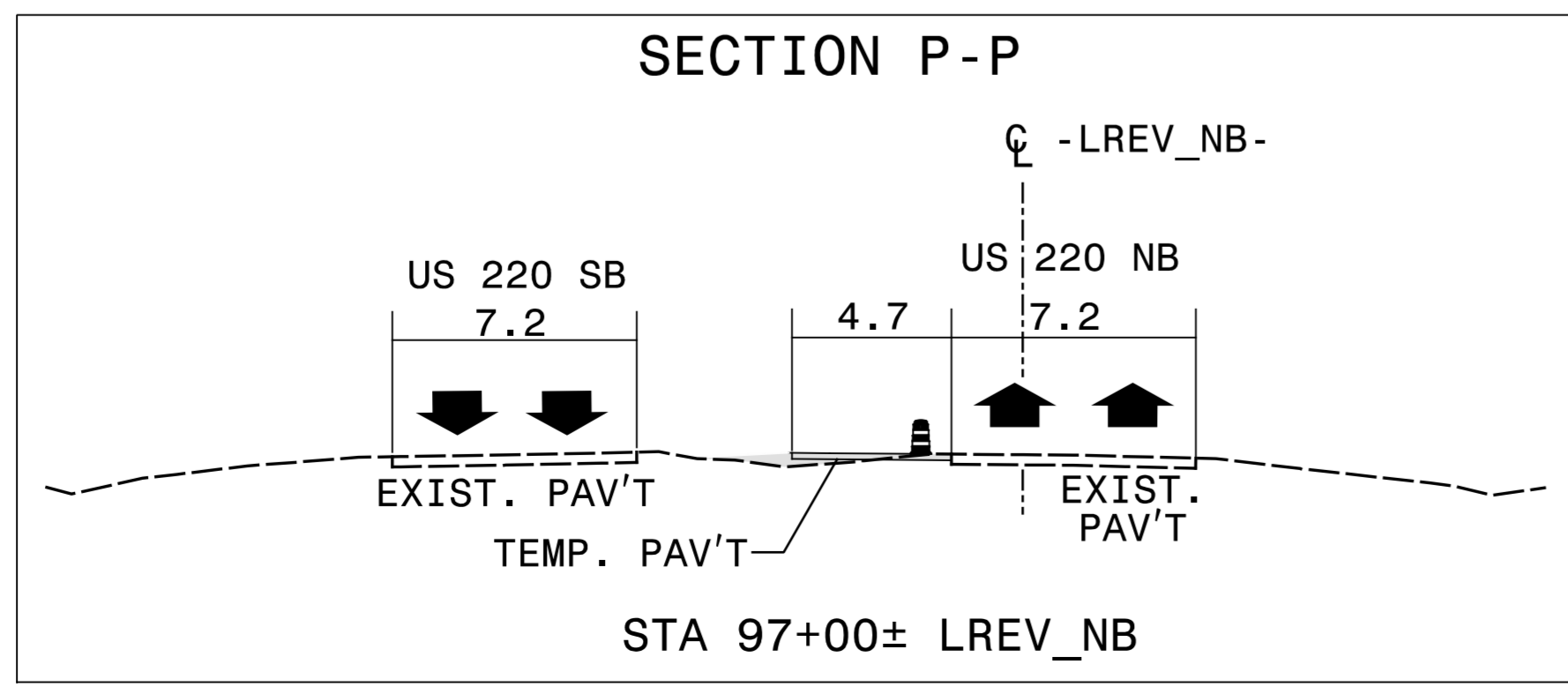
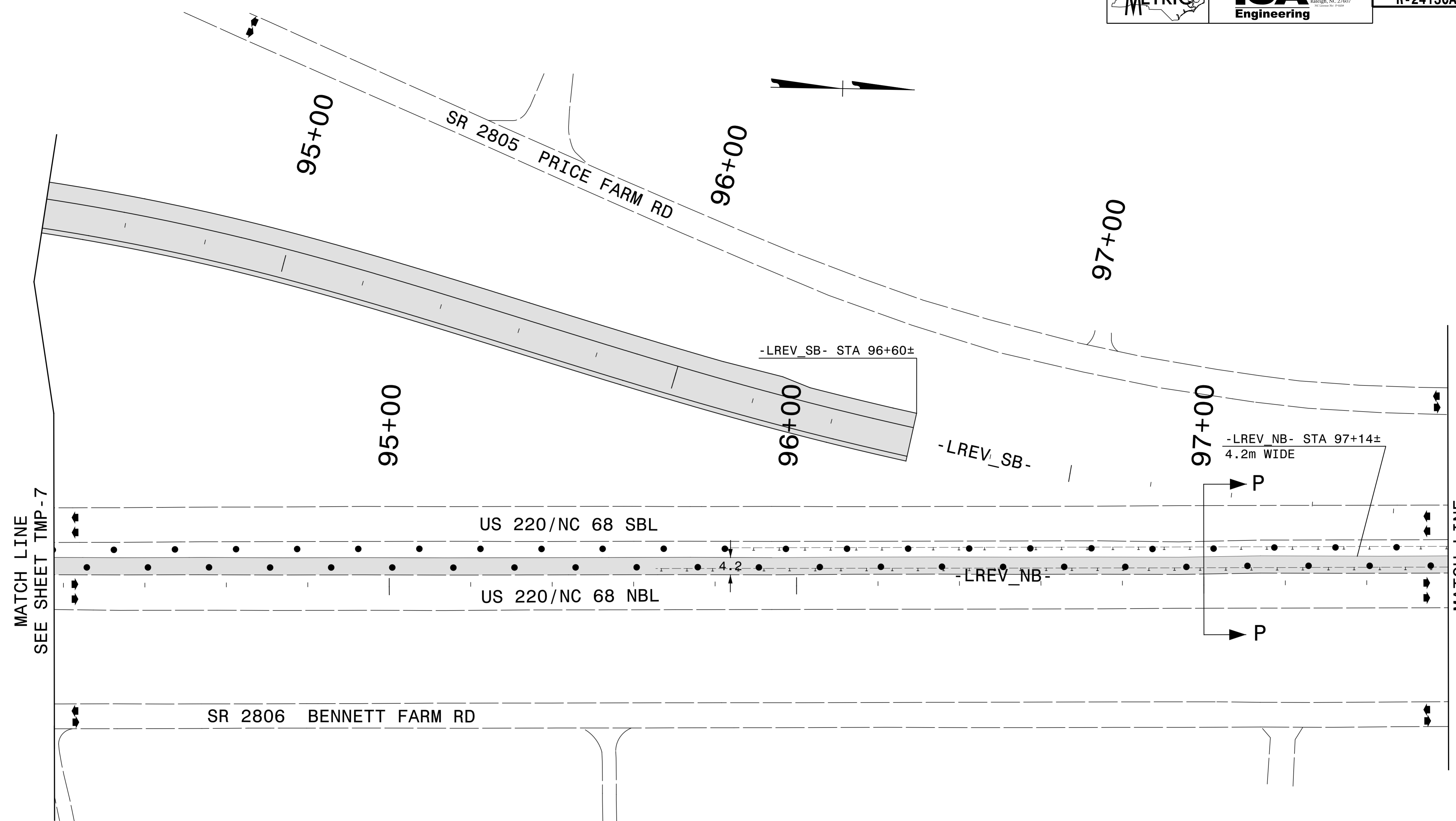
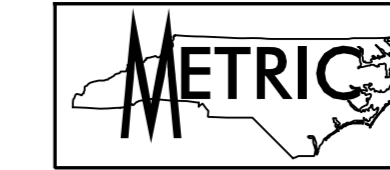

APPROVED: *Michael T. Rzepka* DATE: 2/12/2015

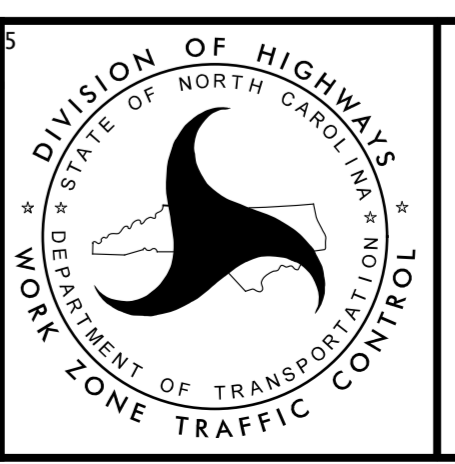
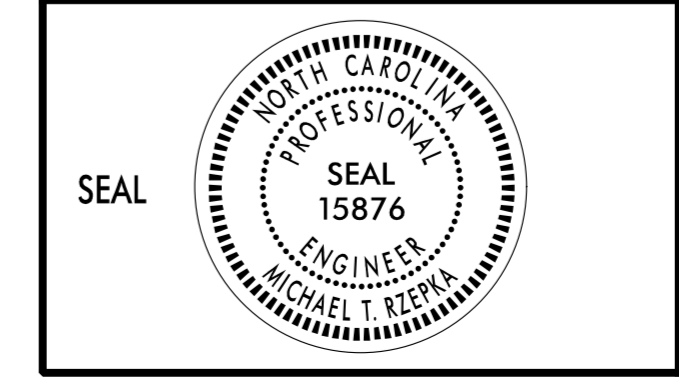

PHASE I, STEP 2
DETAIL

2/11/2015
 R:\Traffic\TrafficControl\TCPV\2413ca_tcp_pi_s2.dtl_23a.dgn
 Florence & Hutchison, Inc.

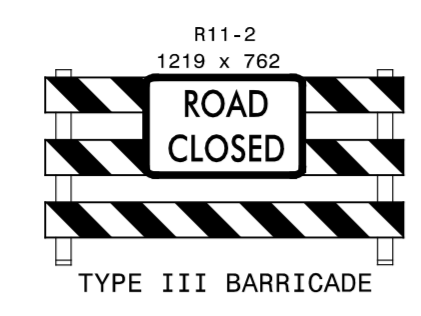

①



98+00

98+00

99+00

100+00

101+00

-LREV_SB STA 98+72± LB =
 -LREV_NB STA 98+39± LB =
 -LREV_END- STA 98+41± LA

SR 2805 PRICE FARM RD

-LREV_END- STA 100+76±

MATCH LINE
SEE SHEET TMP-8

-LREV_SB-

-LREV_END- STA 98+62±

US 220/NC 68 SBL

-LREV_END-

-LREV_NB-

①

US 220/NC 68 NBL

-LREVENXOVR-

-LREV_END- STA 98+89±

SR 2806 BENNETT FARM RD

2/11/2015
E:\TrafficControl\TrafficControl\TCP\2413ca_tcp_pi_s2_dtl_23b.dgn
Florence & Hutchison, Inc.

APPROVED: *Michael T. Rzepka* DATE: 2/12/2015

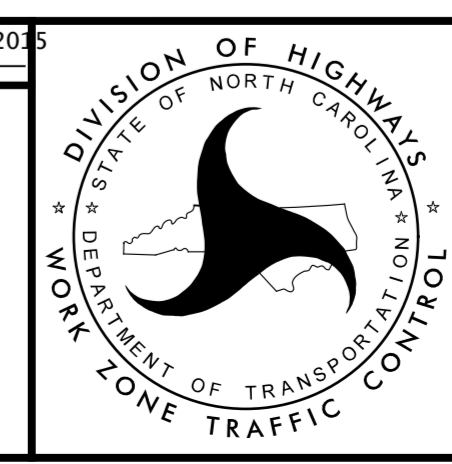
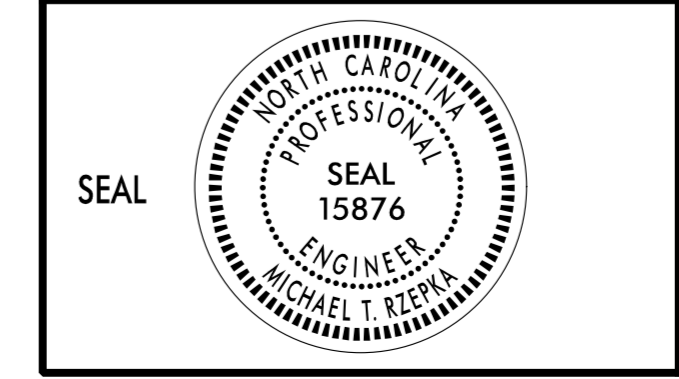

PHASE I, STEP 2
DETAIL

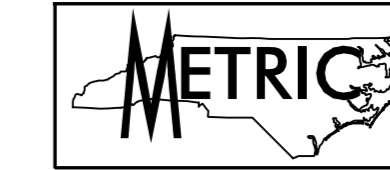

PROJ. REFERENCE NO.	SHEET NO.
R-2413CA	TMP-10

-NC68_MED- STA 10+00=
 -NC68_SB- STA 10+00
 -NC68_NB- STA 10+00

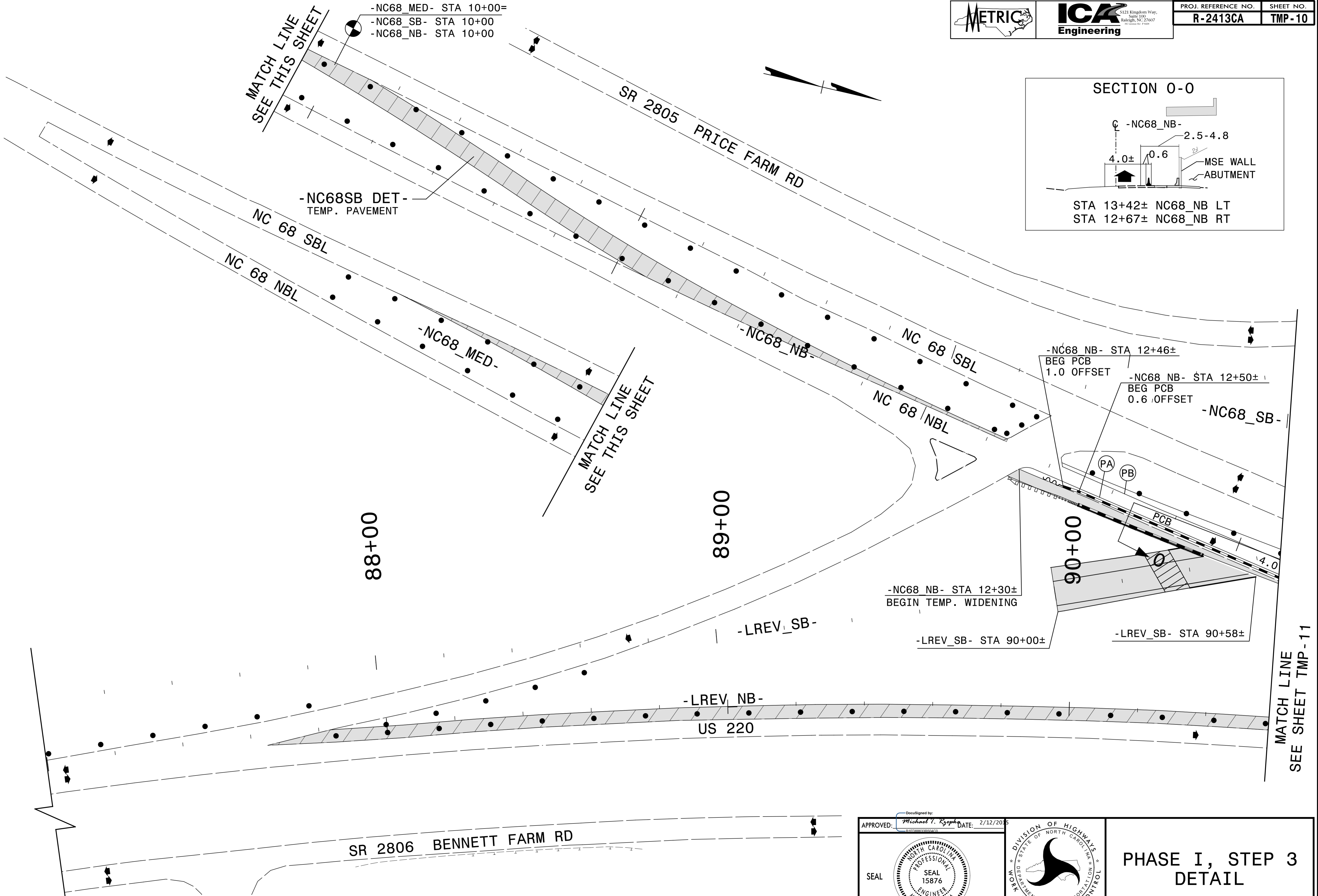
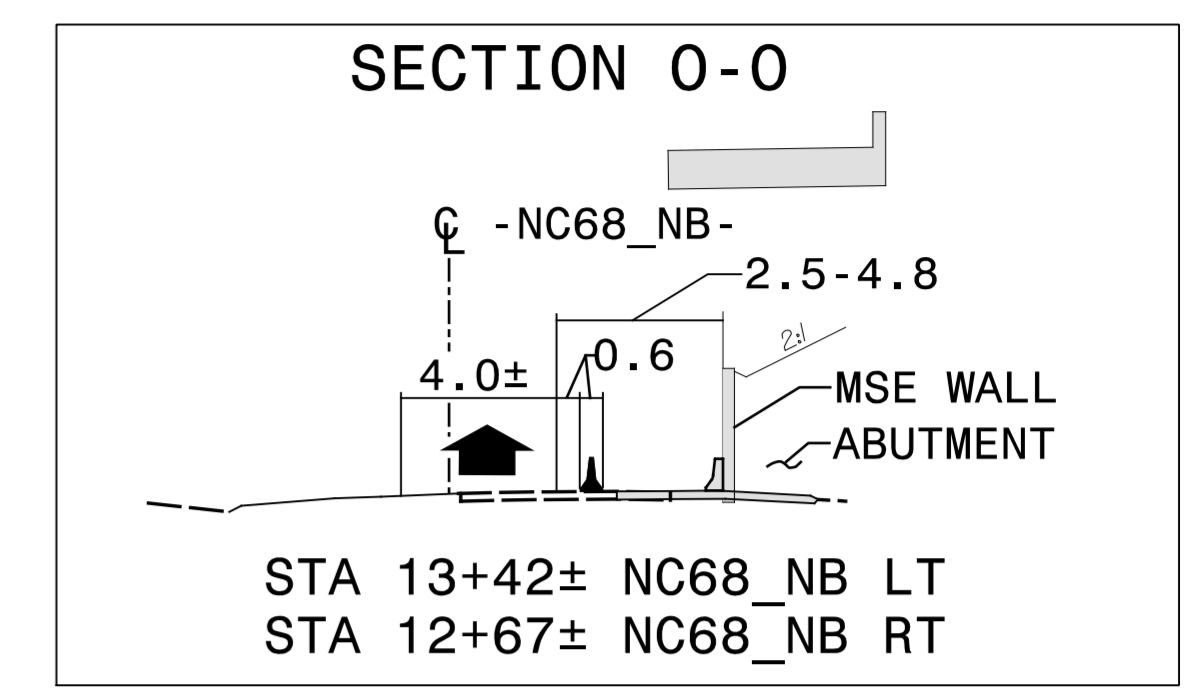

-NC68 NB- STA 12+46±
 BEG PCB
 1.0 OFFSET

-NC68 NB- STA 12+50±
 BEG PCB
 0.6 OFFSET

-NC68_SB-

-NC68 NB- STA 12+30±
 BEGIN TEMP. WIDENING

-LREV_SB- STA 90+00±

-LREV_SB- STA 90+58±

APPROVED: *Michael T. Rzepka* DATE: 2/12/2015

DocuSigned by:
Michael T. Rzepka

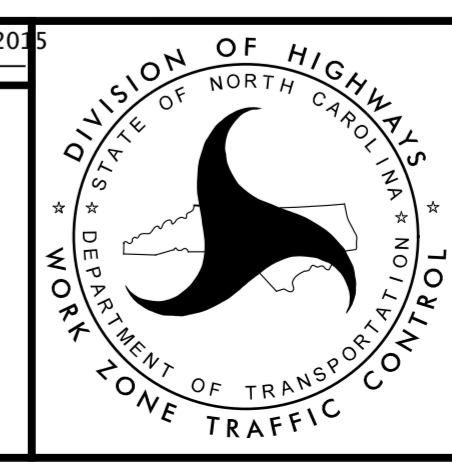

**PHASE I, STEP 3
 DETAIL**

2/11/2015
 R:\Traffic\TrafficControl\TCPV\2413ca_tcp_pi_s3_dtl_22.dgn
 Florence & Hutchison, Inc.

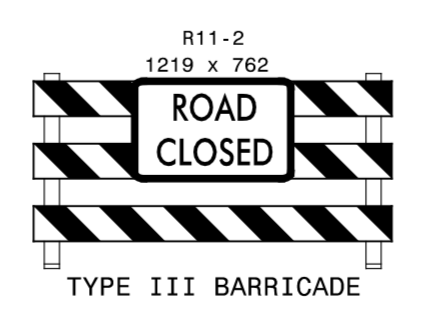
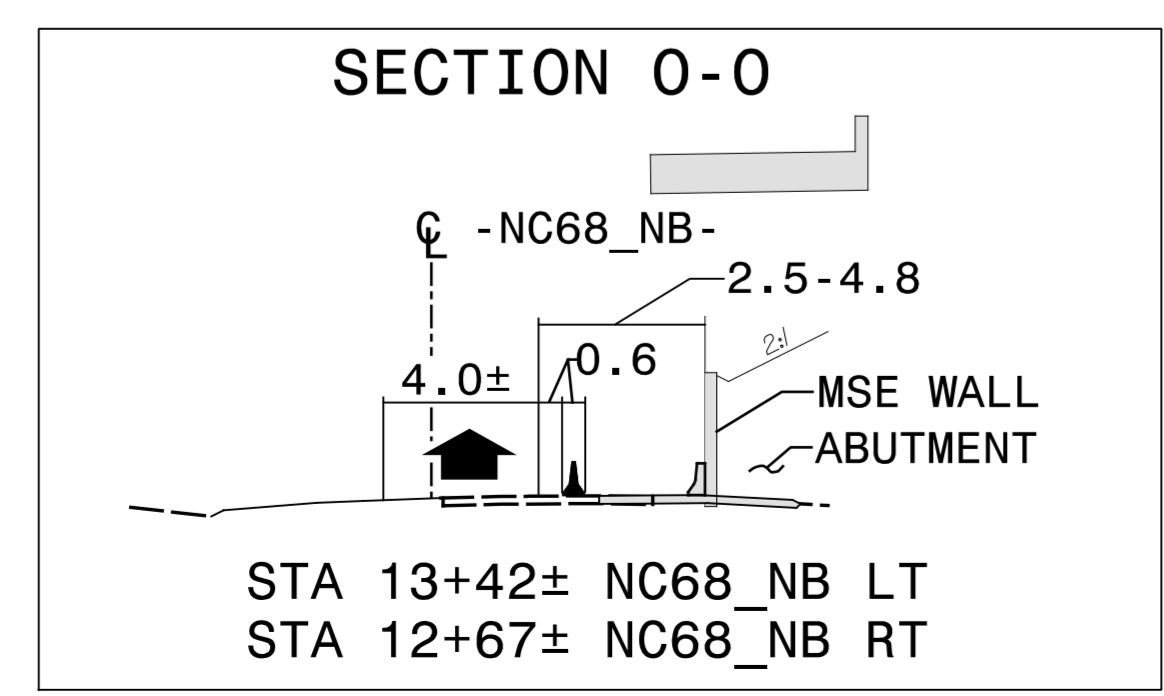
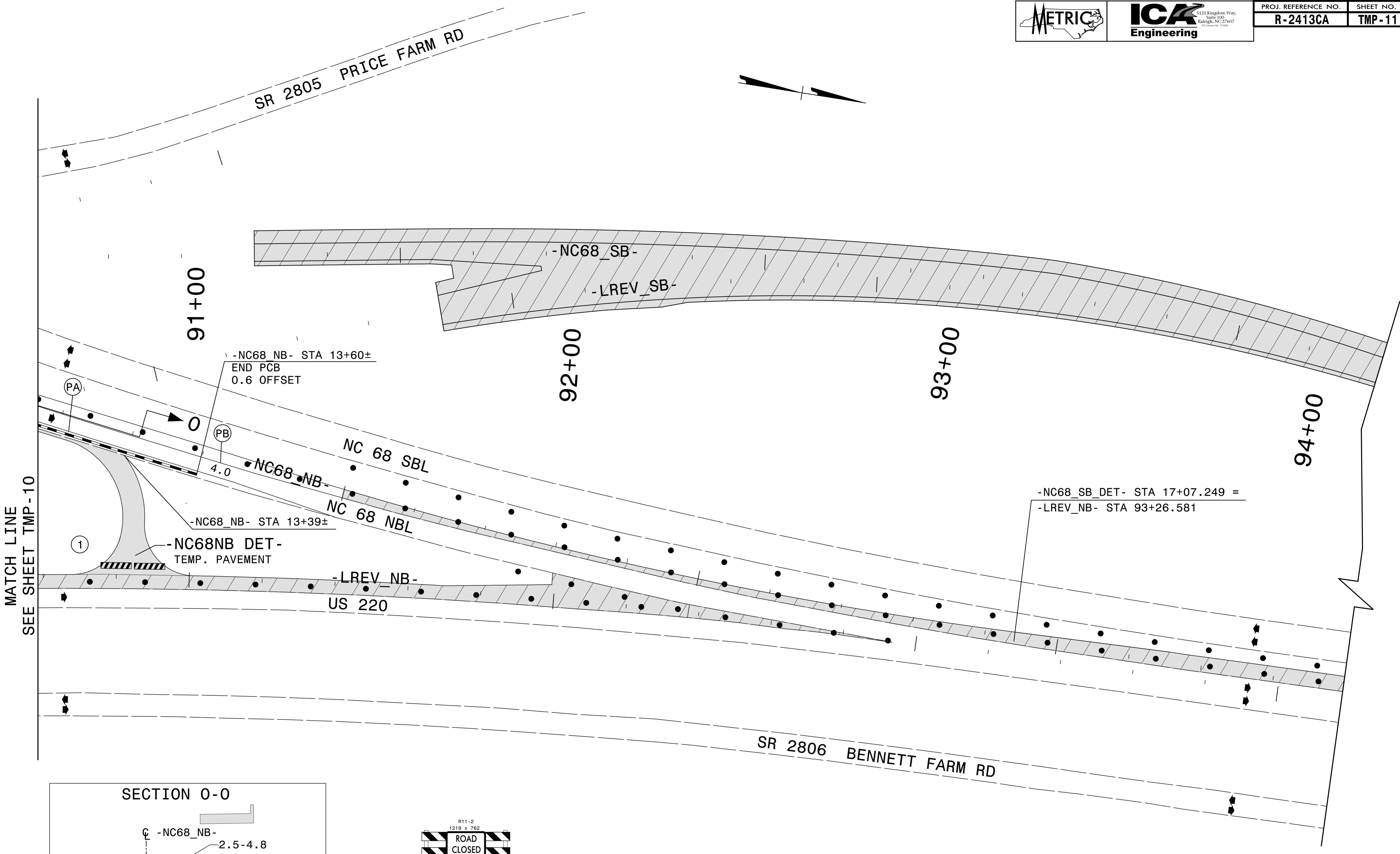

①

APPROVED: *Michael T. Rzepka* DATE: 2/12/2015

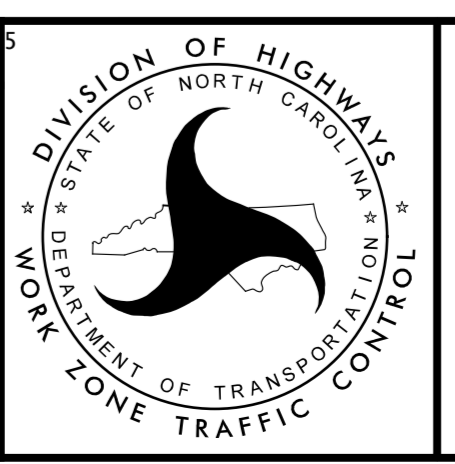
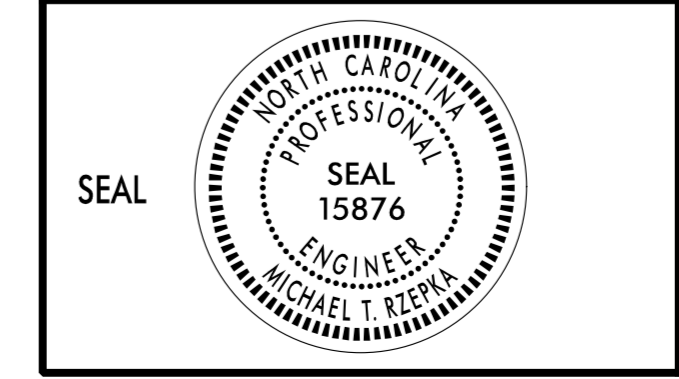

**PHASE I, STEP 3
DETAIL**

2/11/2015
 P:\Trat\Fig_TrafficControl\TCPV-2413ca_tcp_pi_s3_dtl_23.dgn
 Florence & Hutchison, Inc.

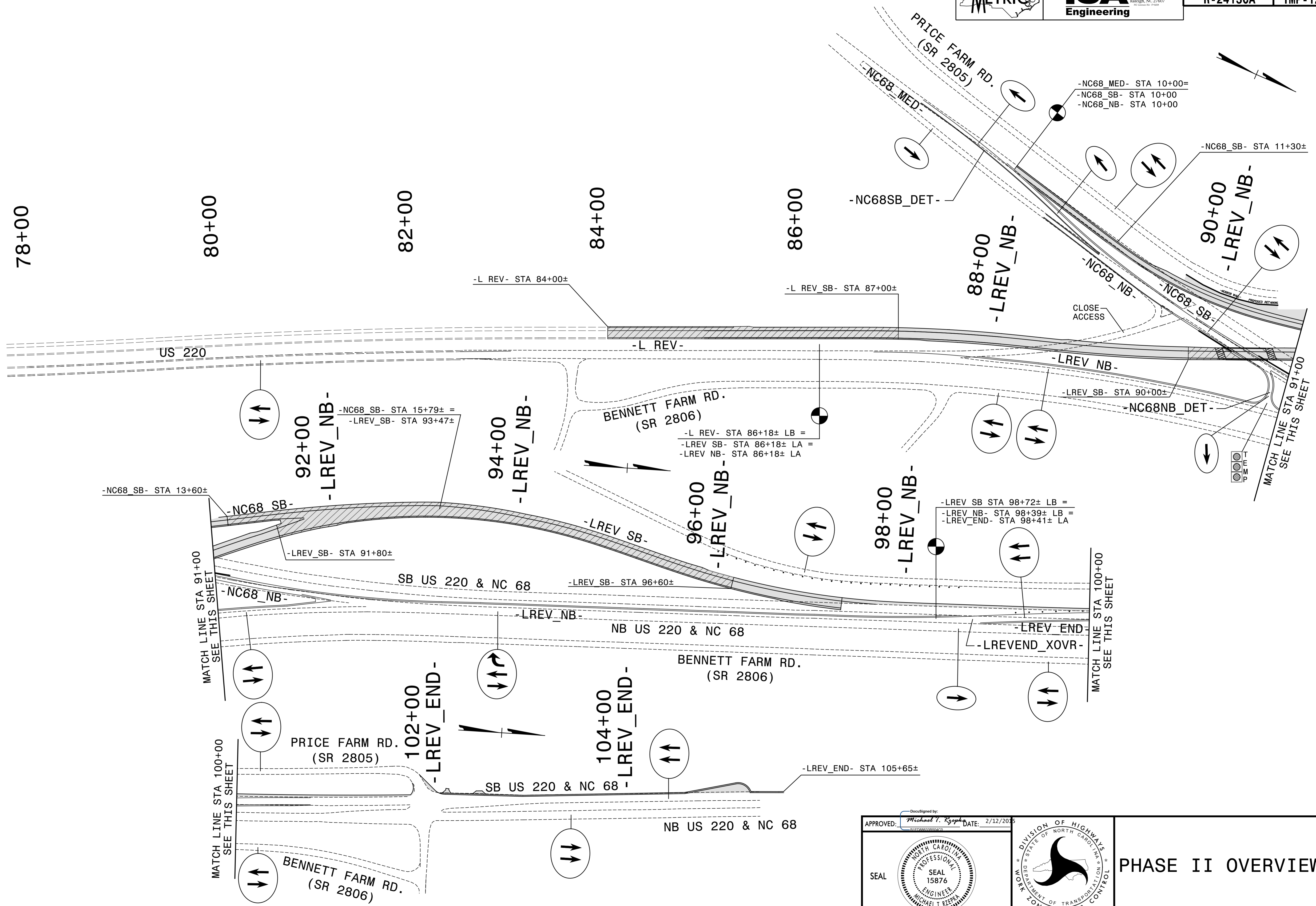

2/12/2015
 R:\Traffic\TrafFicControl\TCP\2413ca_tcp_pil_ovw_e.dgn
 Florence & Hutchison, Inc.

APPROVED: *Michael T. Ryngaert* DATE: 2/12/2015

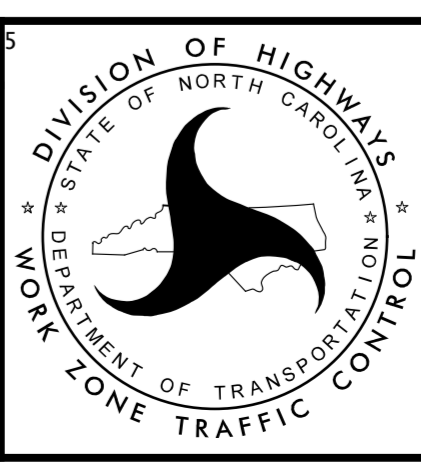
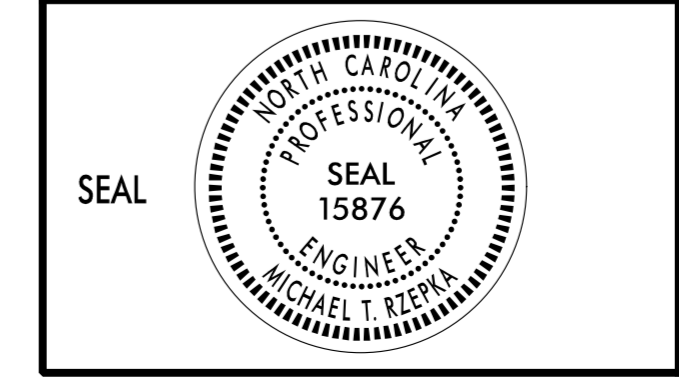

PHASE II OVERVIEW

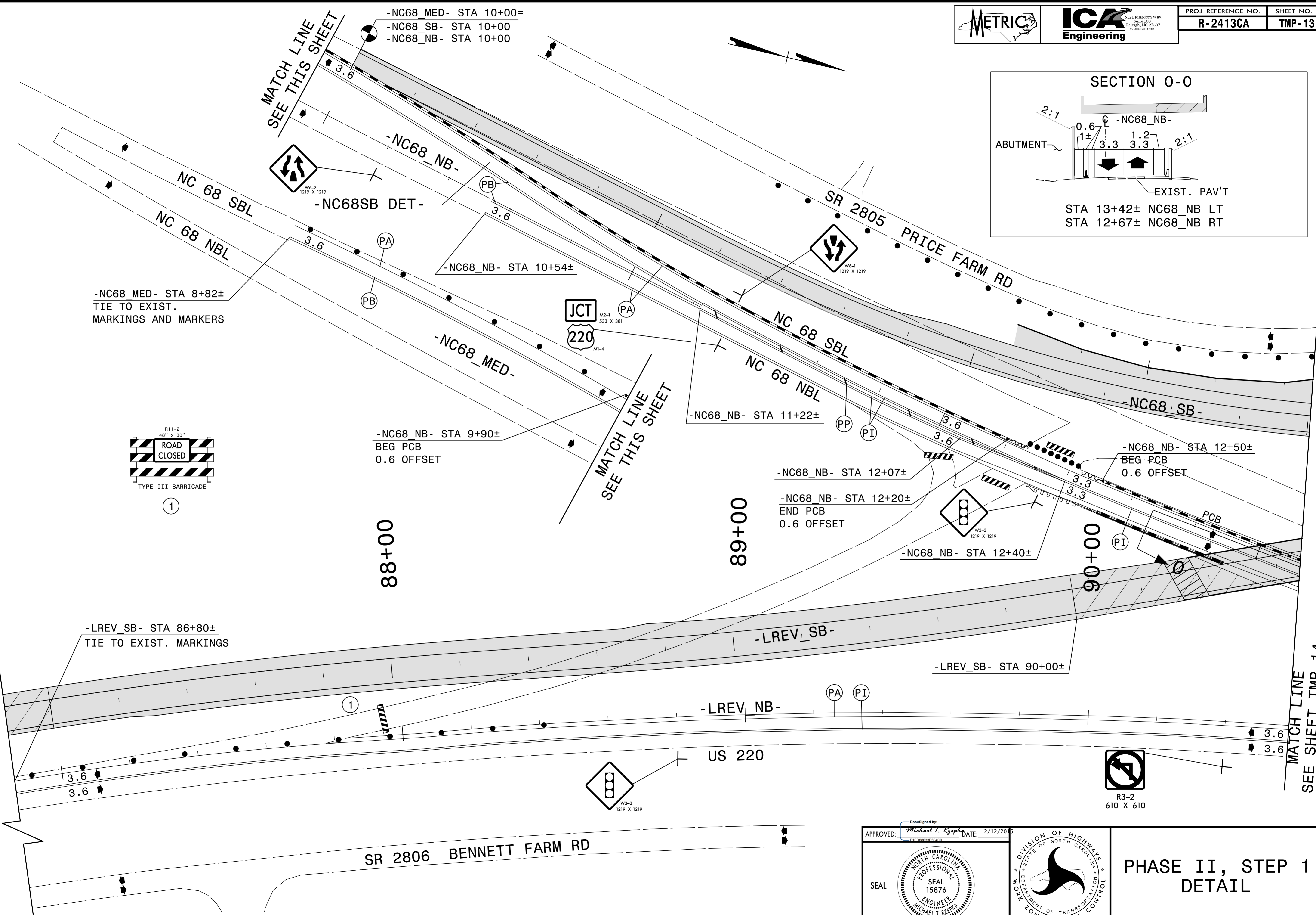
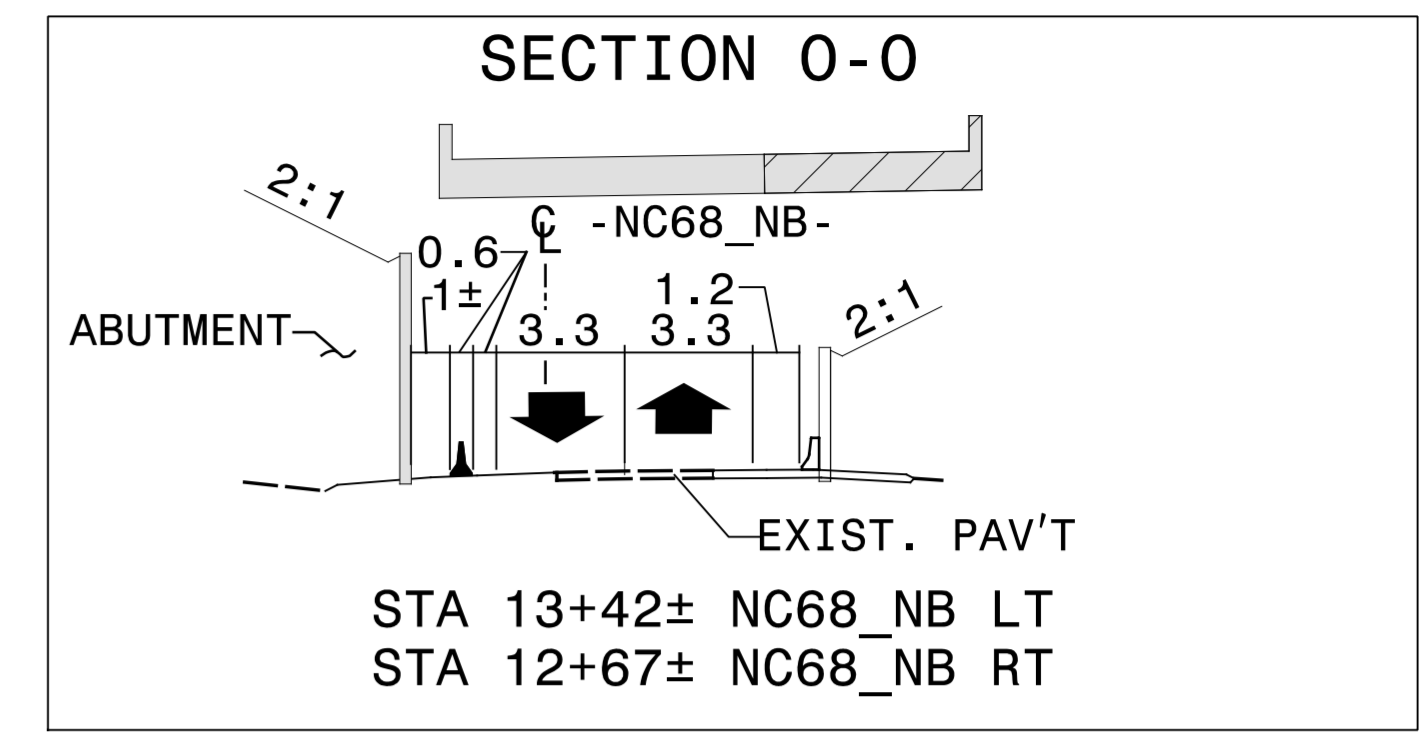
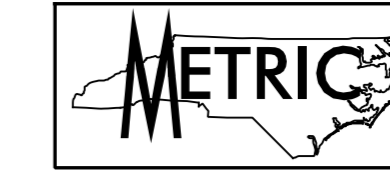

2/11/2015
 R:\TrafFic\TrafFicControl\TCP\2413ca_tcp_pii_dtl_22.dgn
 Florence & Hutchison, Inc.

APPROVED: *Michael T. Rzepka* DATE: 2/12/2015

DocuSigned by:
 Michael T. Rzepka

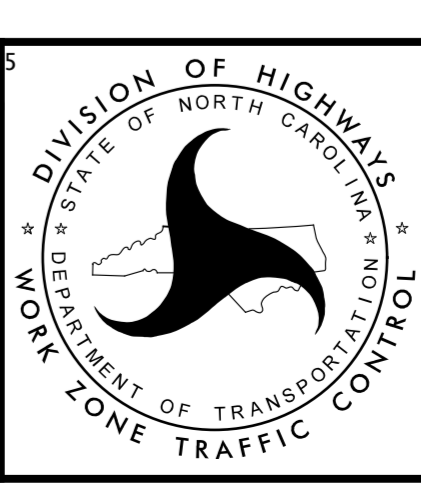

PHASE II, STEP 1
 DETAIL

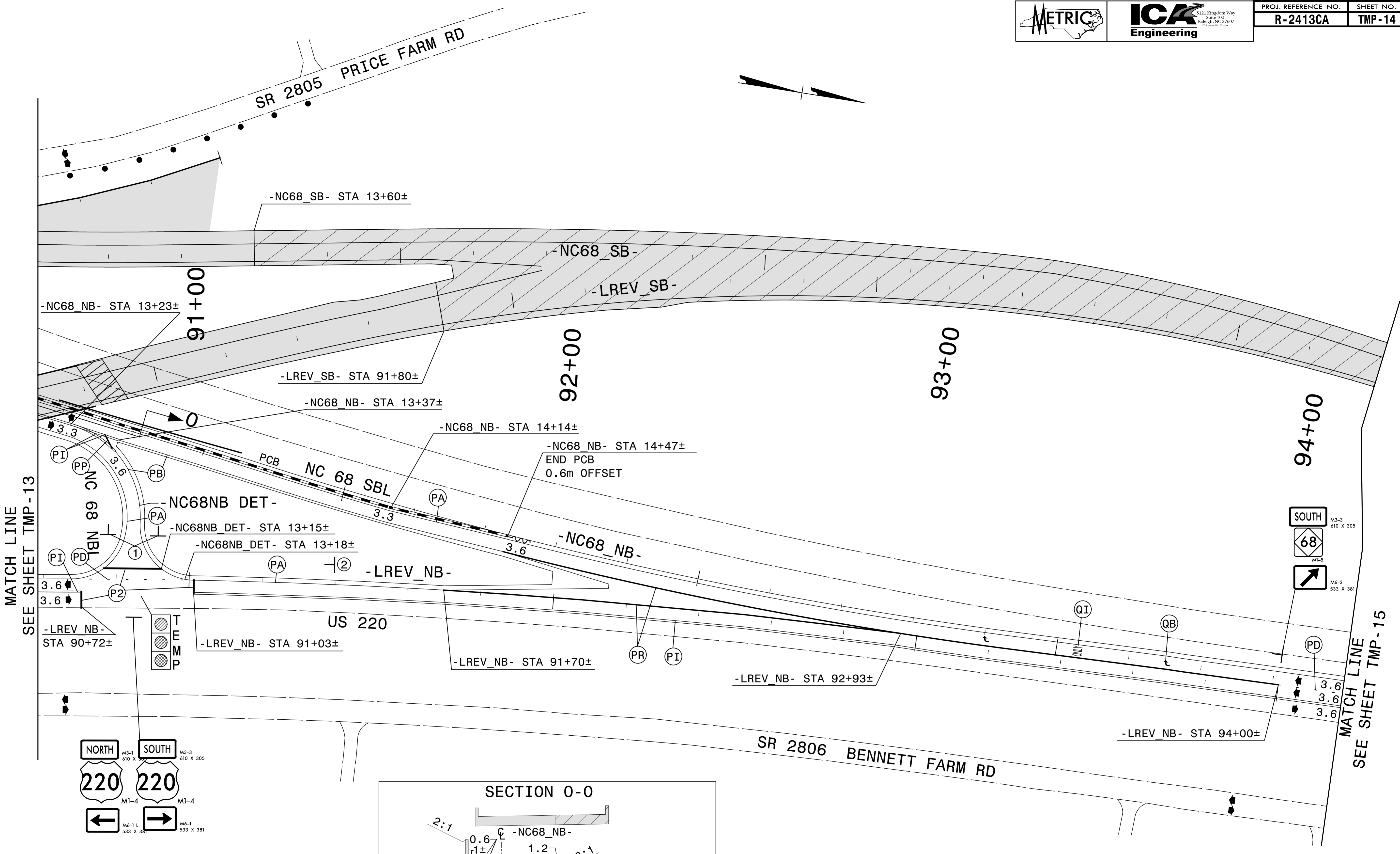
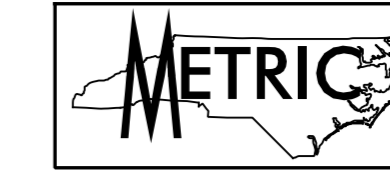

MATCH LINE
SEE SHEET TMP-13

MATCH LINE
SEE SHEET TMP-15

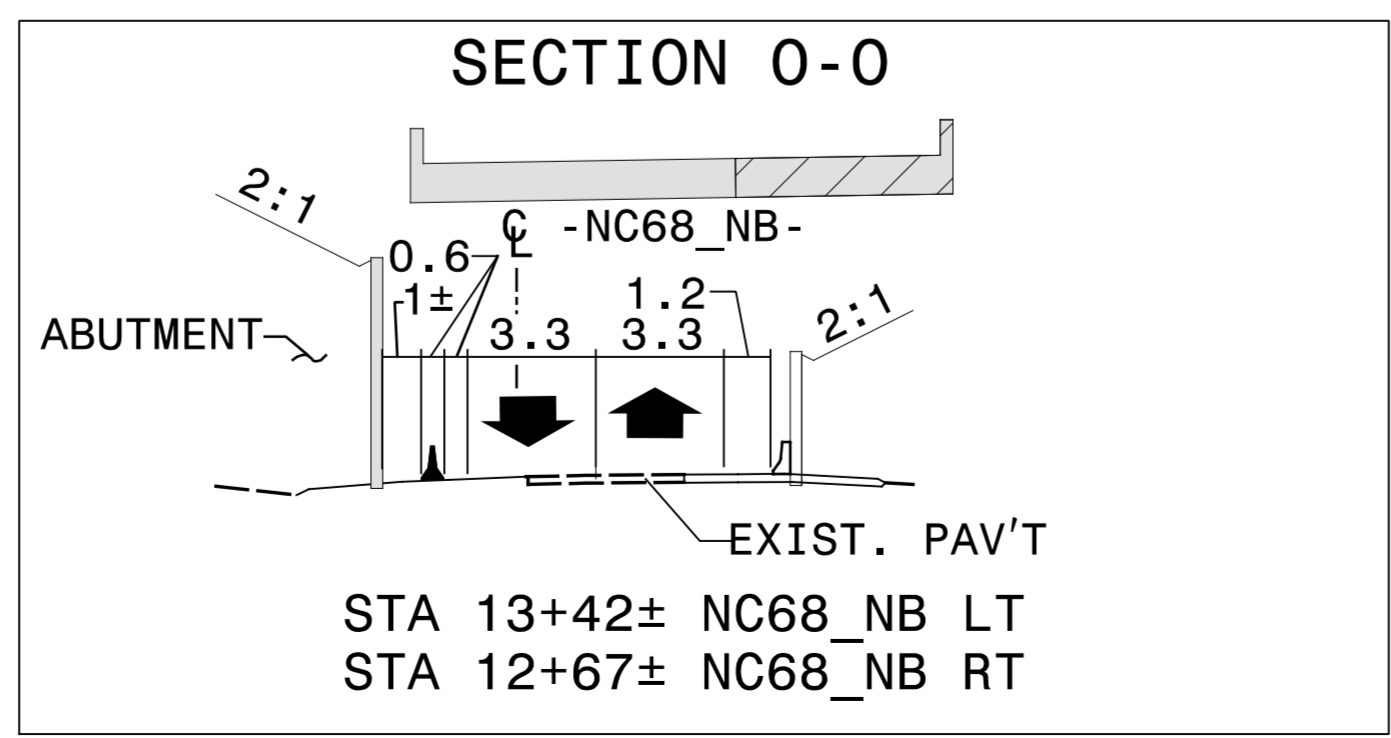
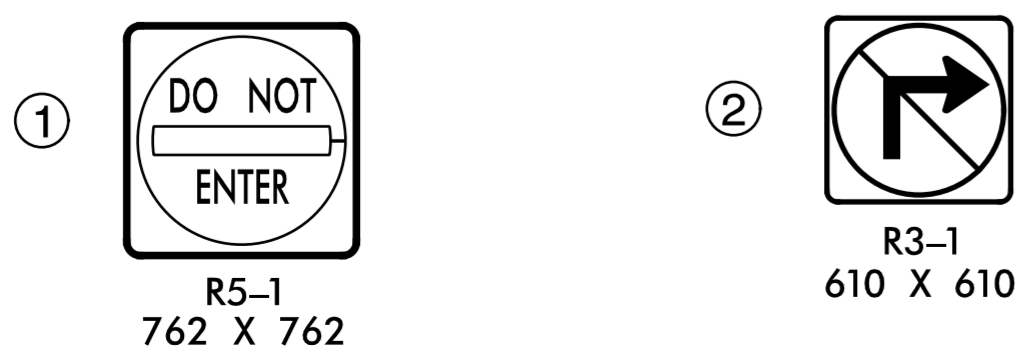
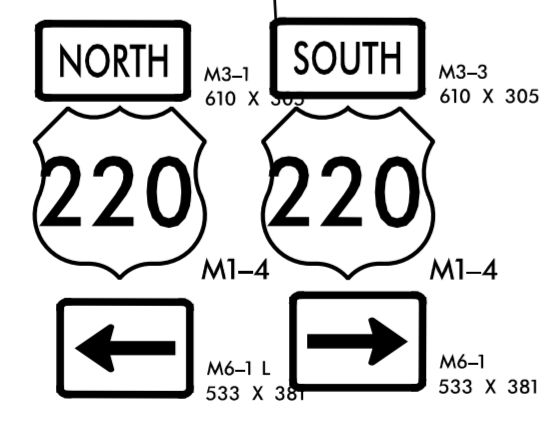

APPROVED: *Michael T. Rzepka* DATE: 2/12/2015

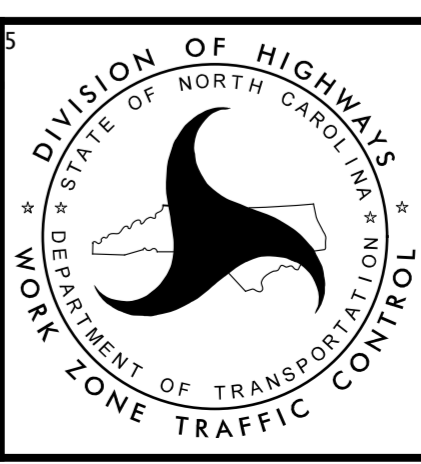

**PHASE II, STEP 1
DETAIL**

2/11/2015 10:41:11 AM R:\TrafficControl\CPV\2413ca_tcp_pii.dtl_23.dgn Florence & Hydrocon, Inc.

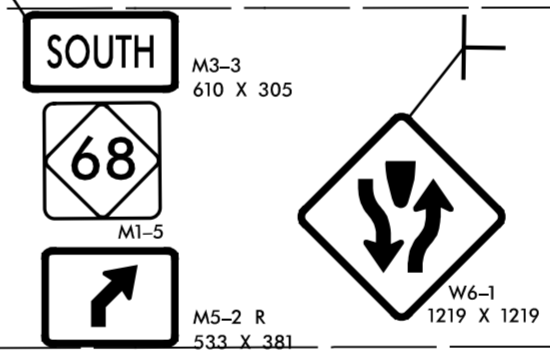
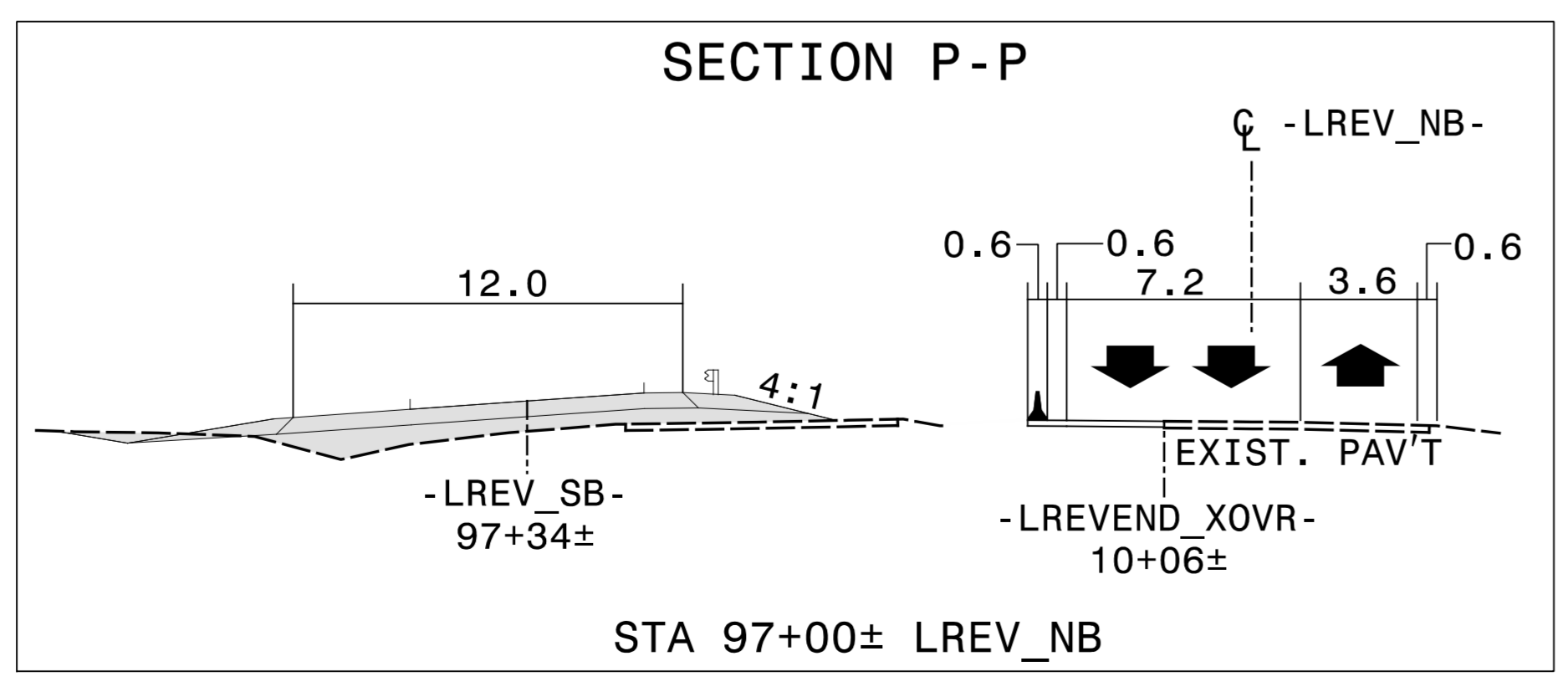
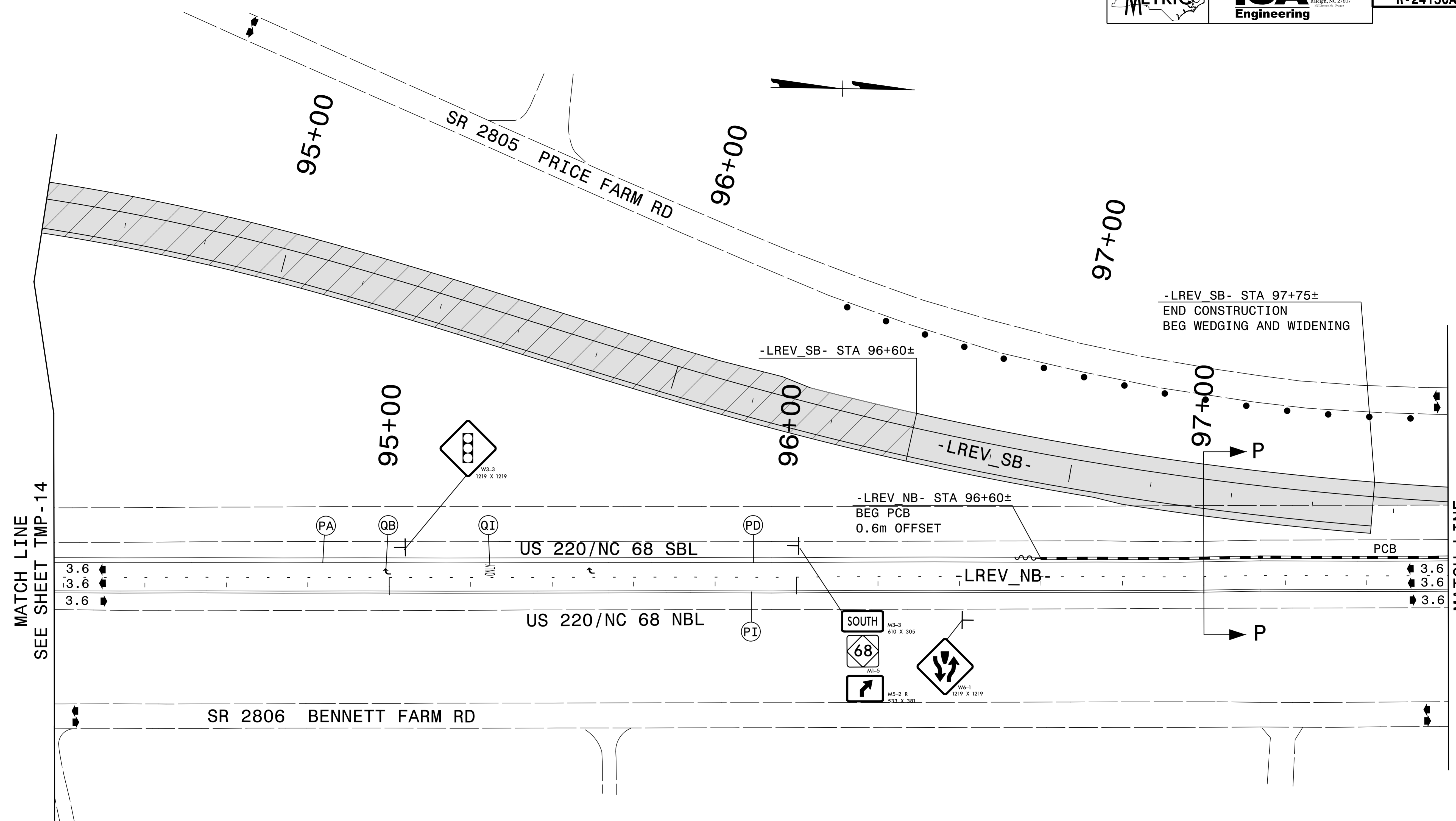

APPROVED: *Michael T. Rzepka* DATE: 2/12/2015

DocuSigned by: Michael T. Rzepka

SEAL

PROFESSIONAL SEAL 15876

ENGINEER MICHAEL T. RZEPKA

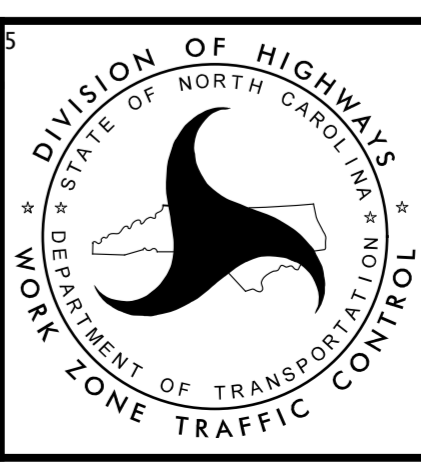

PHASE II, STEP 1
 DETAIL

2/11/2015
 R:\Trat\Fig_TrafficControl\TCP\2413ca_tcp_pii_dtl_23a.dgn
 Florence & Hutchison, Inc.

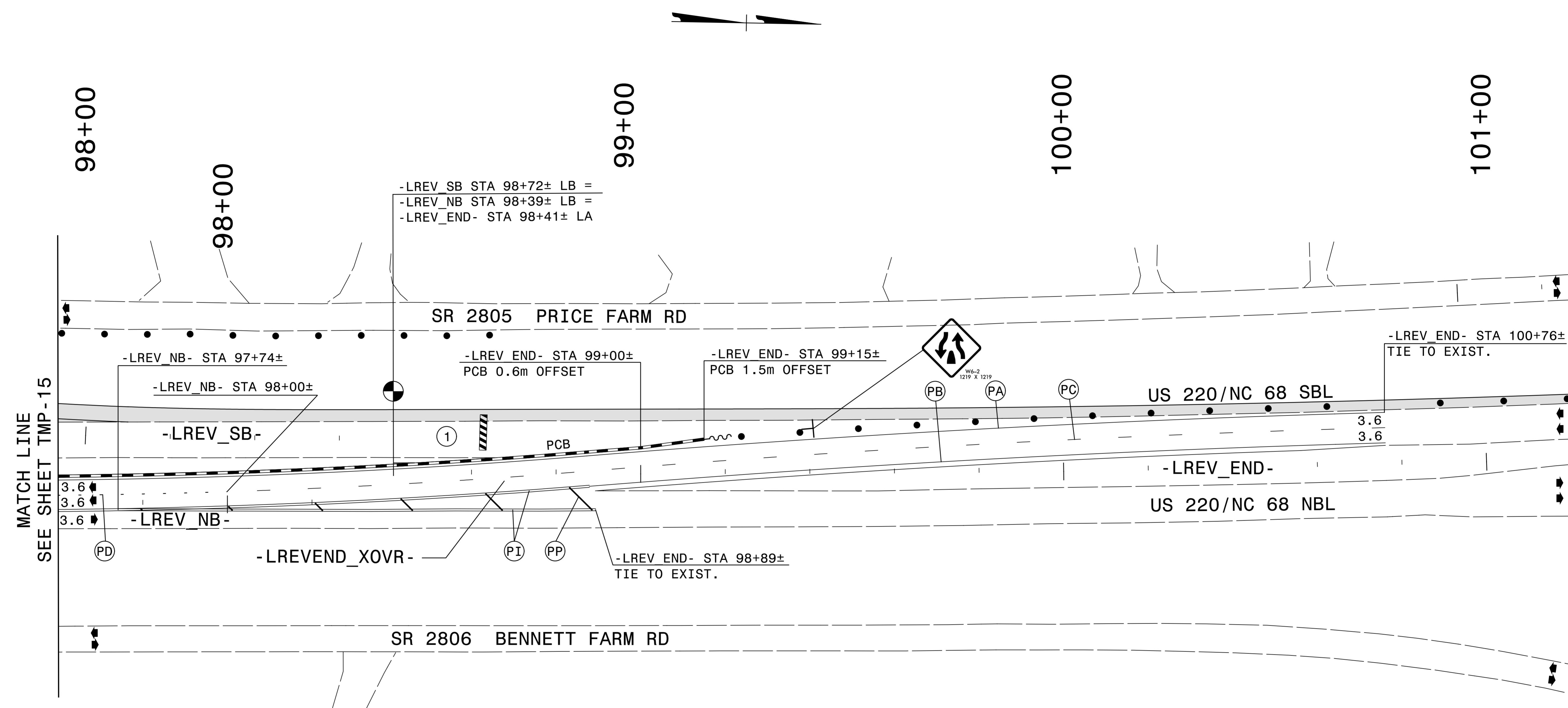

MATCH LINE SEE SHEET TMP-15

MATCH LINE SEE SHEET TMP-17

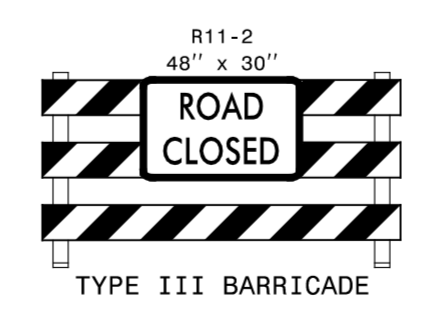

1

APPROVED: Michael T. Rzepka DATE: 2/12/2015

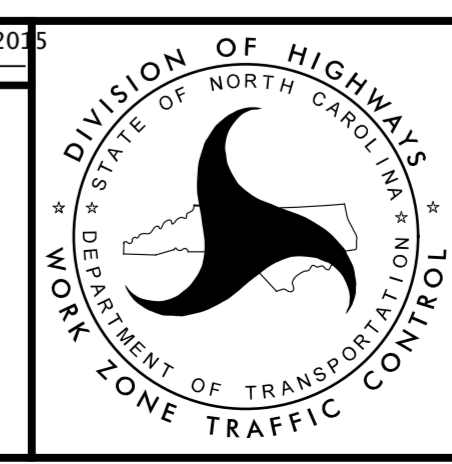
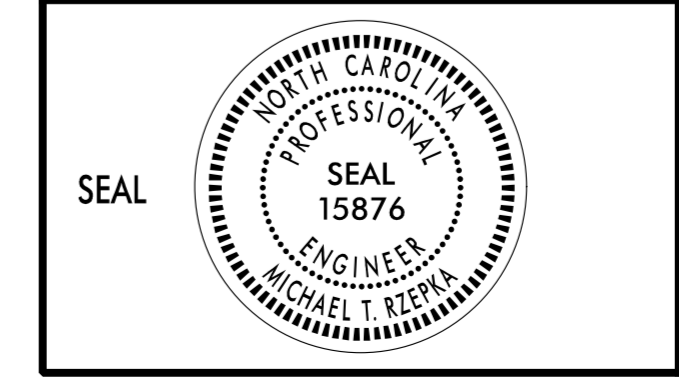

PHASE II, STEP 1
DETAIL

2/11/2015
E:\Traffic\TrafficControl\TCP\2413ca_tcp_pii.dtl_23b.dgn
Florence & Hutchison, Inc.



PROJ. REFERENCE NO.	SHEET NO.
R-2413CA	TMP-17

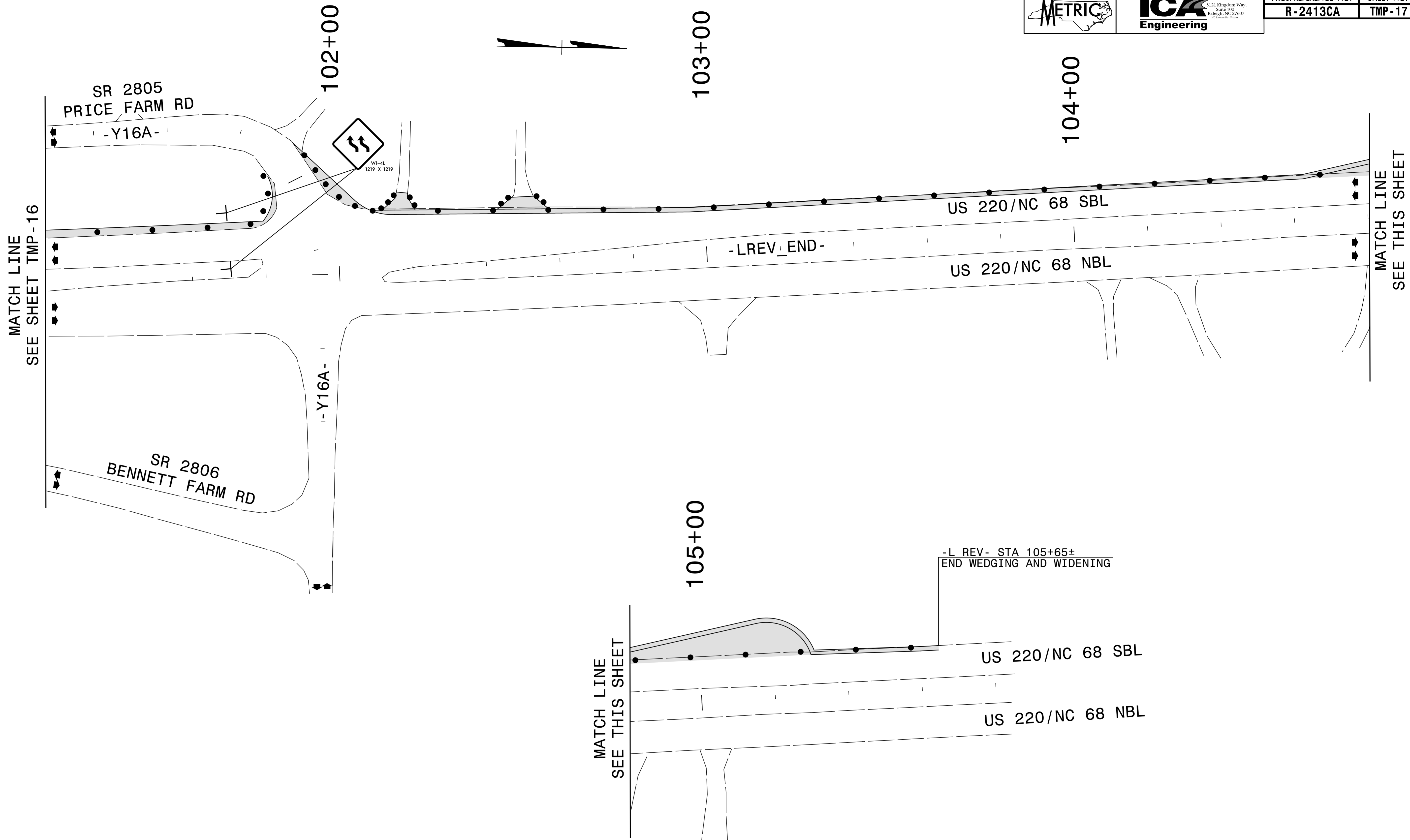

2/11/2015
 R:\Traffic\TrafficControl\TCP\2413ca_tcp_pii.dtl_23c.dgn
 Florence & Hutchison, Inc.

APPROVED: *Michael T. Rygala* DATE: 2/12/2015

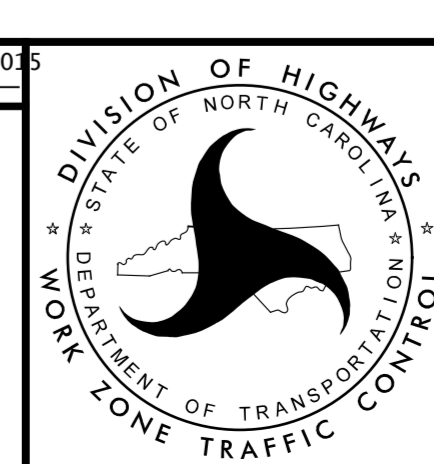
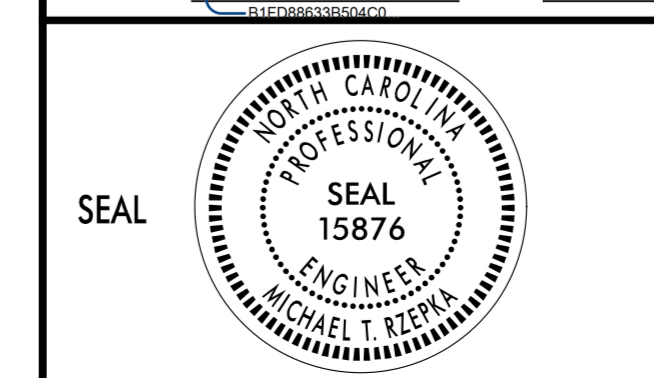

PHASE II, STEP 1
 DETAIL

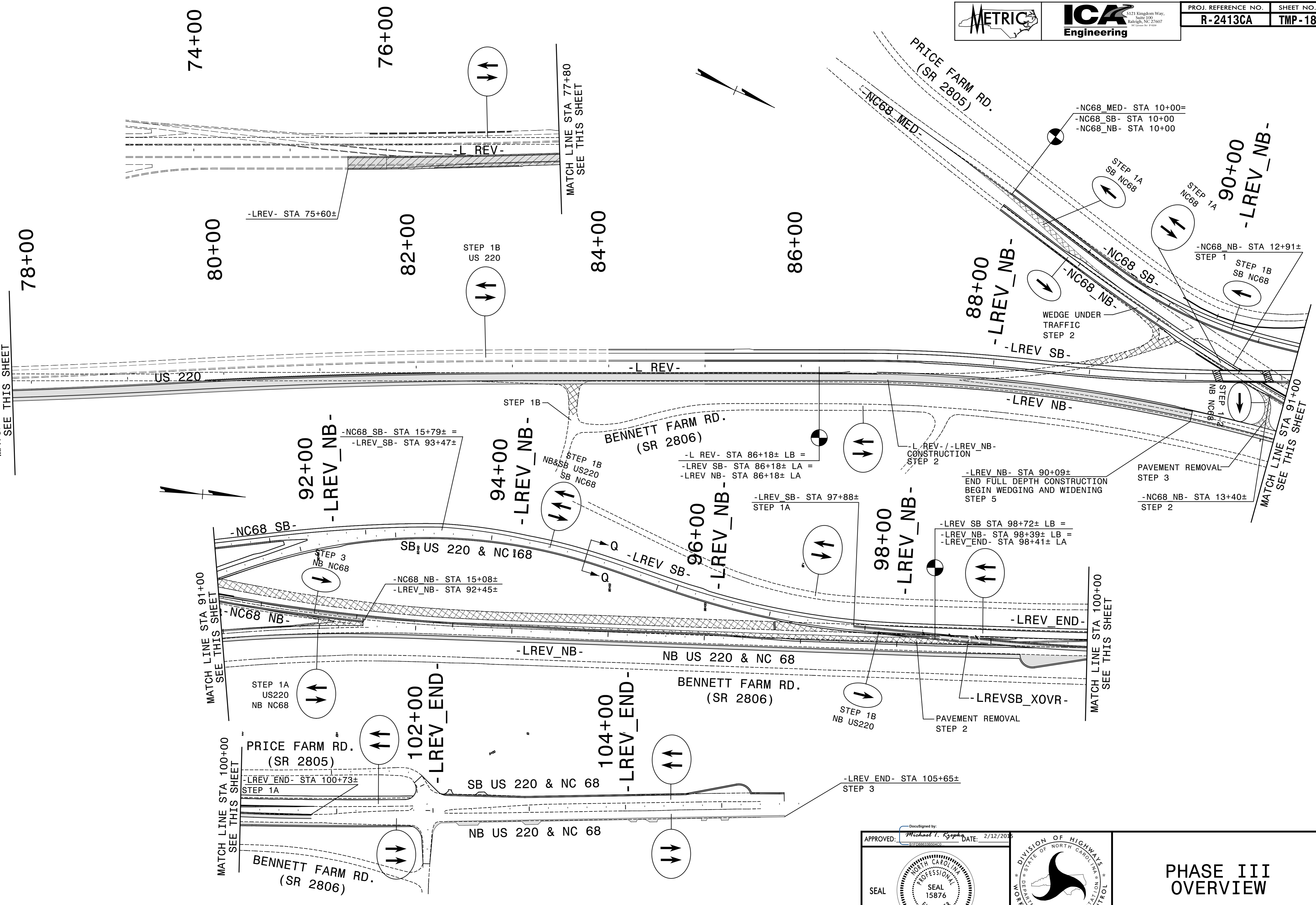

2/11/2015
 R:\Traffic\TrafficControl\TCP\2413ca_tcp.plt_0vw_e.dgn
 Florence & Hutcheson, Inc.

APPROVED: *Michael L. Kye* DATE: 2/12/2015

SEAL

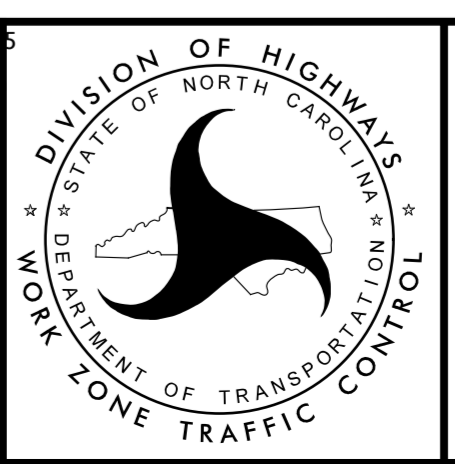

PHASE III OVERVIEW

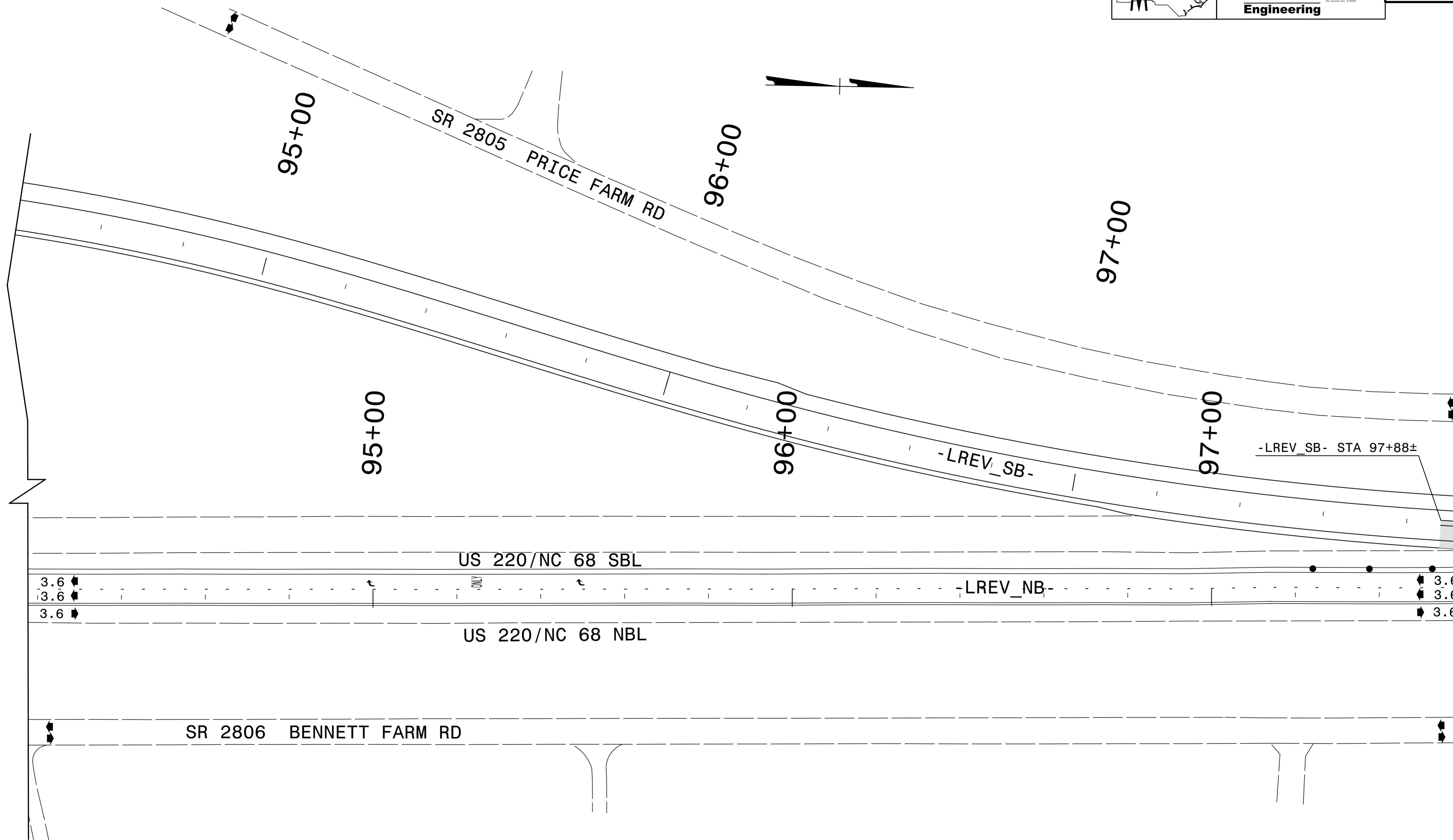

MATCH LINE
SEE SHEET TMP-20

2/11/2015
E:\Traffic\TrafficControl\TCP\2413ca_tcp.plt\sl_dtl_23a.dgn
Florence & Hutchison, Inc.

APPROVED: *Michael T. Rzepka* DATE: 2/12/2015

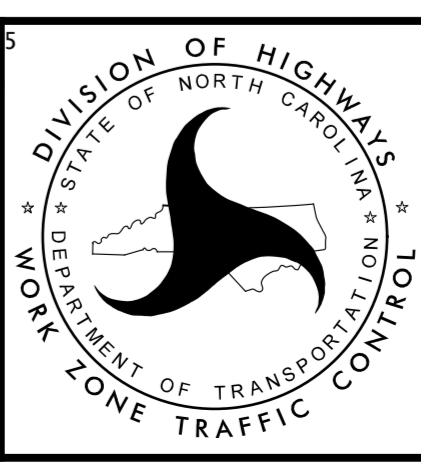
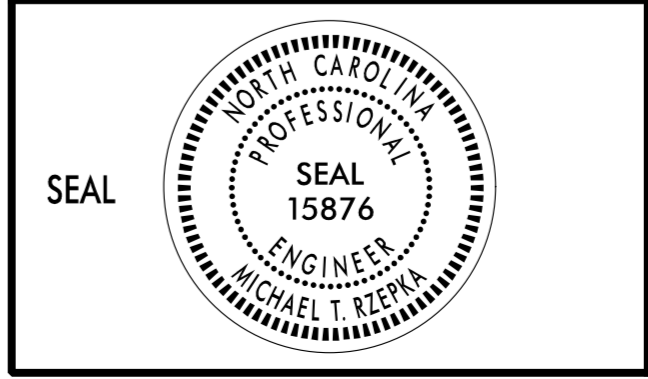

**PHASE III, STEP 1
DETAIL**

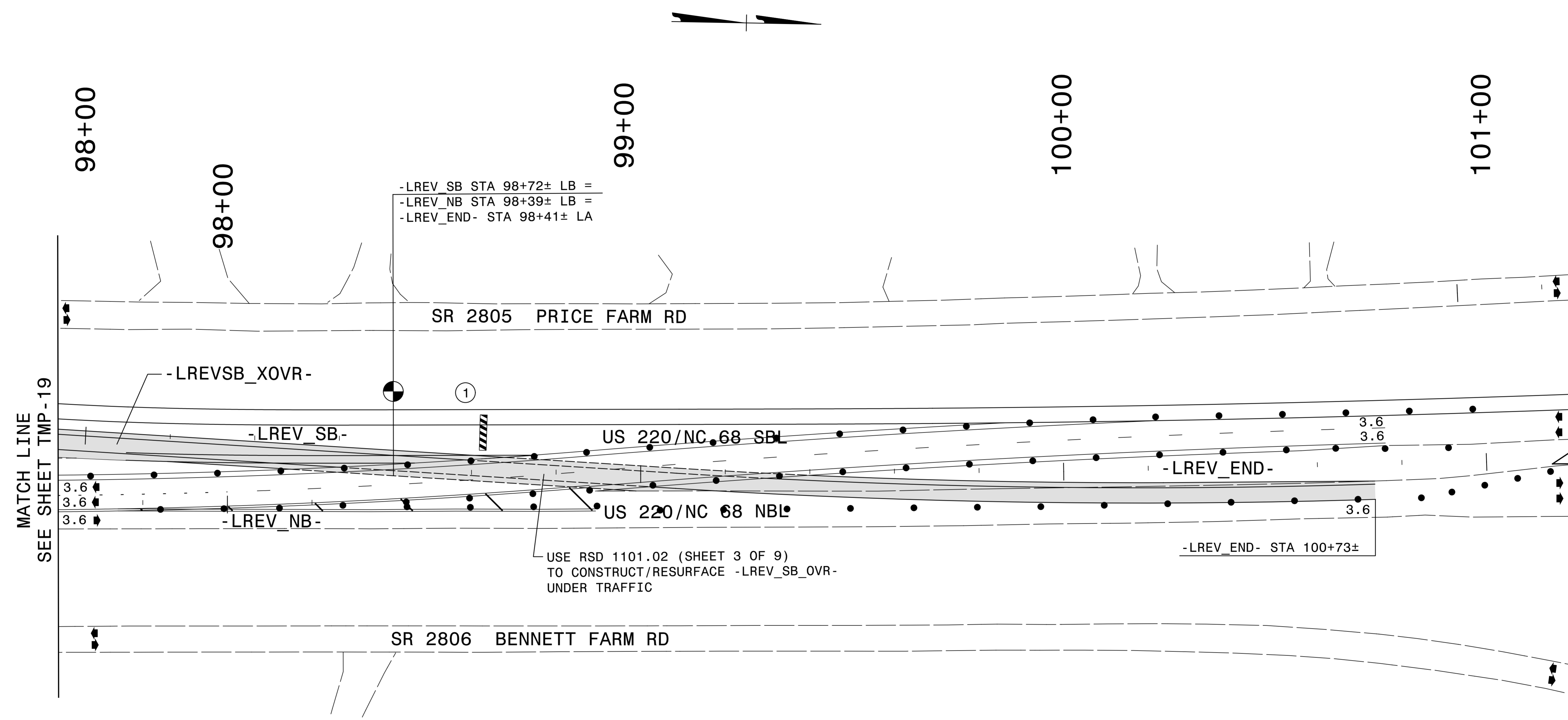
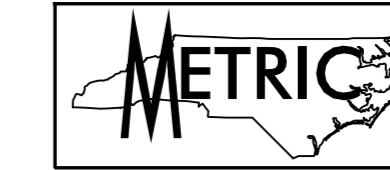

MATCH LINE
SEE SHEET TMP-19

USE RSD 1101.02 (SHEET 3 OF 9)
TO CONSTRUCT/RESURFACE -LREV_SB_OVR-
UNDER TRAFFIC

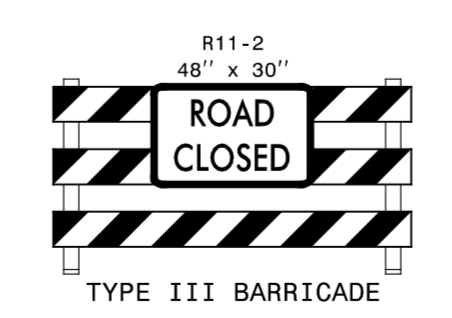

1

APPROVED: *Michael T. Rzepka* DATE: 2/12/2015

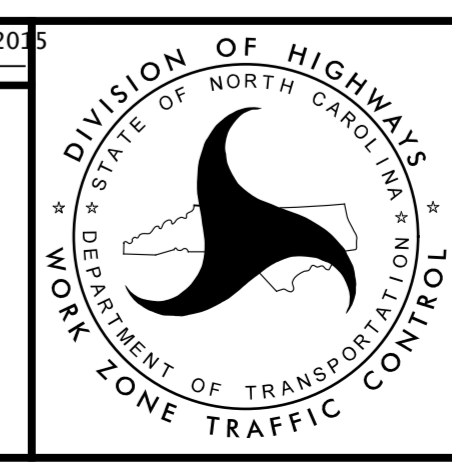

PHASE III, STEP 1
DETAIL

2/11/2015
R:\Traffic\TrafficControl\TCP\2413ca_tcp_plt1.dwg
Florence & Hutchison, Inc.



73+00

74+00

75+00

76+00

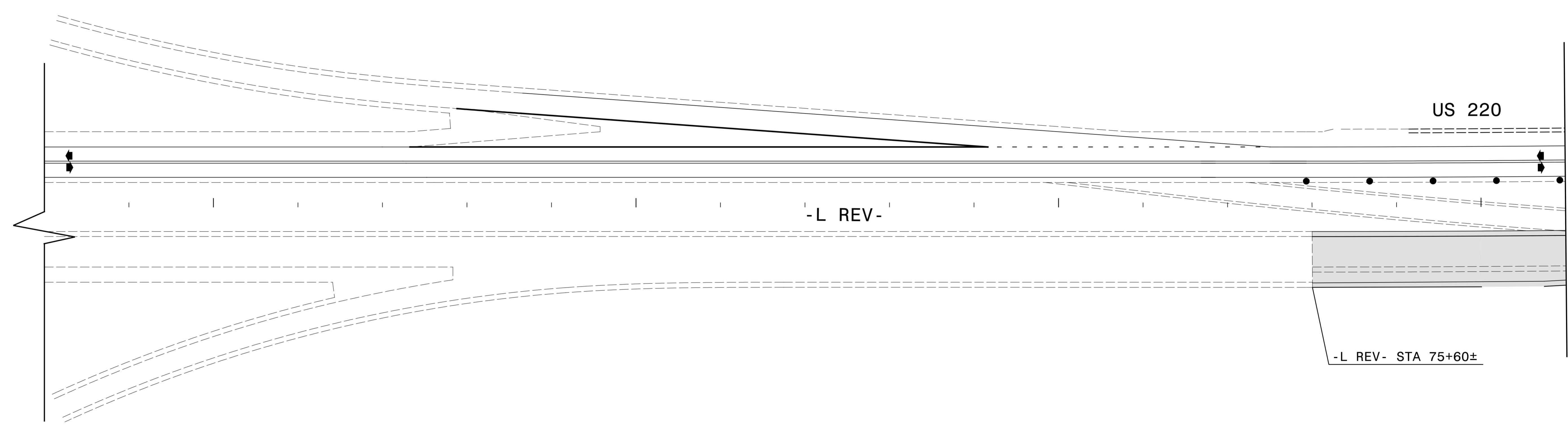
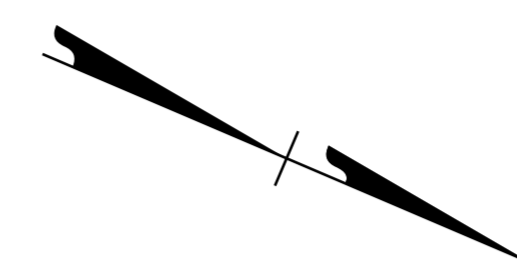

2/11/2015
 R:\Traffic\TrafficControl\TCP\2413ca_tcp_piii_s2_dtl_18.dgn
 Florence & Hutcheson, Inc.

DocuSigned by: APPROVED: <i>Michael L. Rzepka</i> DATE: 2/12/2015 <small>81E92883382400</small>				<p style="text-align: center;">PHASE III, STEP 2 DETAIL</p>
SEAL				

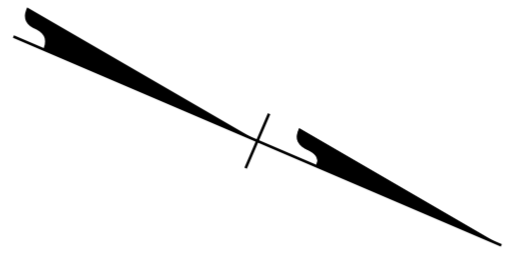

77+00

78+00

79+00

MATCH LINE
SEE SHEET TMP-21

MATCH LINE
SEE SHEET TMP-23

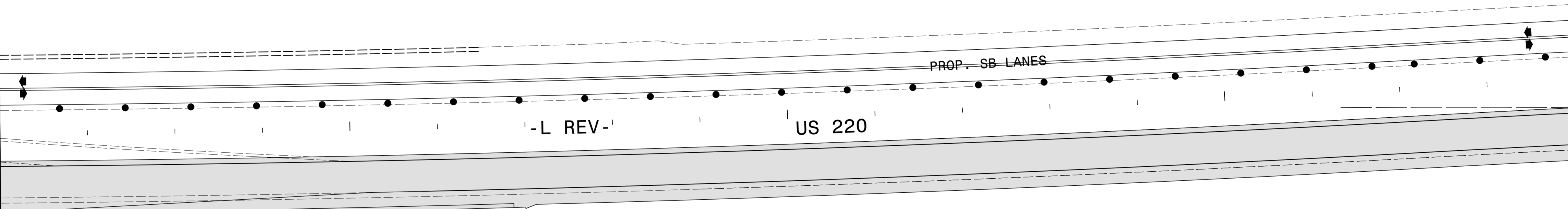

2/11/2015
R:\Traffic\TrafficControl\TCP\2413ca_tcp_piii_s2_dtl.dgn
Florence & Hutcheson, Inc.

DocuSigned by:
 APPROVED: *Michael L. Ryzko* DATE: 2/12/2015
 SEAL

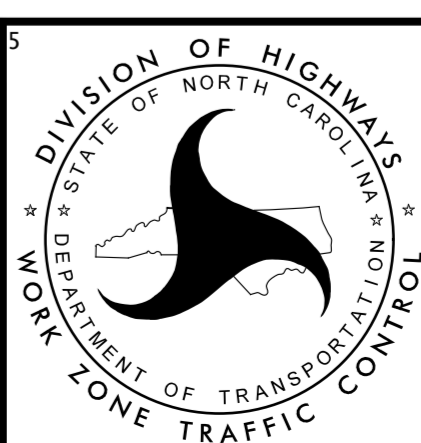

PHASE III, STEP 2
DETAIL



80+00

81+00

82+00

83+00

MATCH LINE
SEE SHEET TMP-22

MATCH LINE
SEE SHEET TMP-24

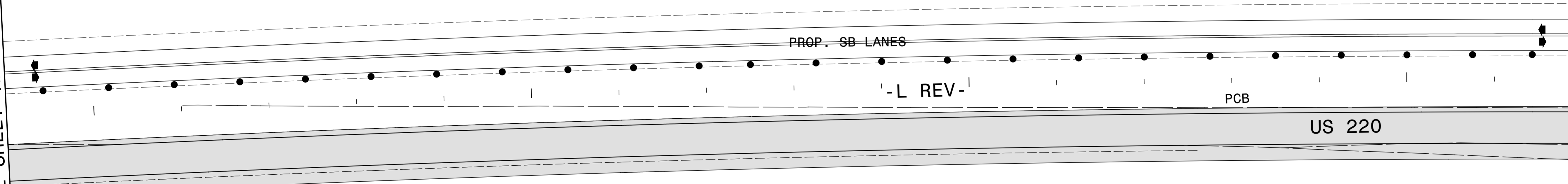
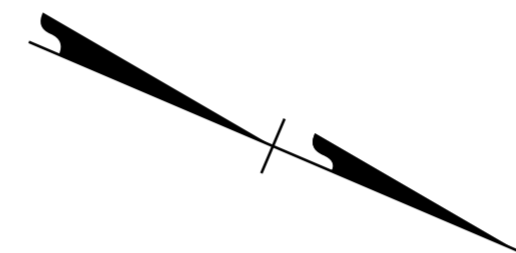

2/11/2015
R:\Traffic\TrafficControl\TCP\2413ca_tcp_piii_s2_dtl_20.dgn
Florence & Hutcheson, Inc.

APPROVED: <i>Michael L. Rzepka</i> DATE: 2/12/2015 <small>81E0883382400</small>				<p>PHASE III, STEP 2 DETAIL</p>
SEAL				

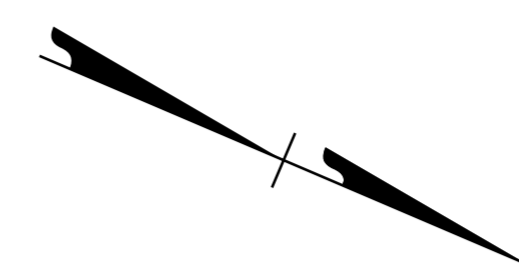

84+00

85+00

86+00

-LREV_SB- STA 84+00±
TIE TO EXIST. MARKINGS

PROP. SHLD.
3.6
3.6

PROP. SHLD.
3.6
3.6

PA

US 220

PI

-LREV_SB-

MATCH LINE
SEE SHEET TMP-23

MATCH LINE
SEE SHEET TMP-25

-L REV-

PROP. NB LANES

-LREV_NB-

SR 2806 BENNETT FARM RD

1

-L REV- STA 86+18± LB =
-LREV SB- STA 86+18± LA =
-LREV NB- STA 86+18± LA

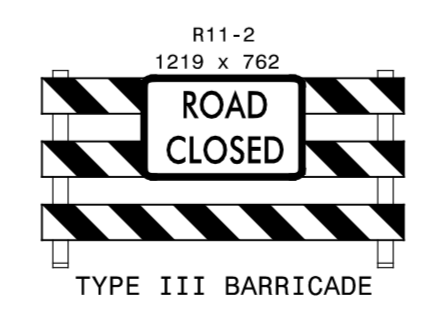

1

APPROVED: *Michael L. Rye* DATE: 2/12/2015

DocuSigned by:
Michael L. Rye

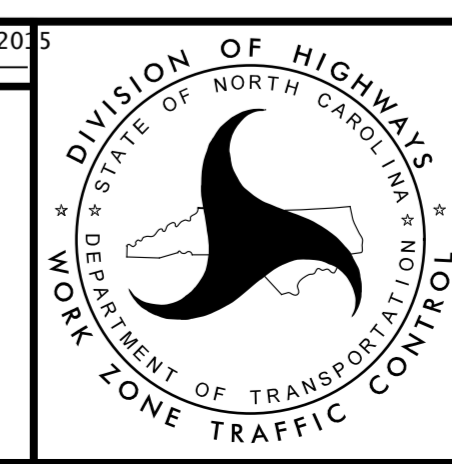

PHASE III, STEP 2
DETAIL

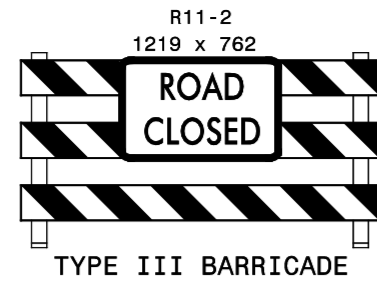

1

-NC68_NB-
STA 10+00±
BEG WEDGING AND
WIDENING

-NC68_MED- STA 10+00=
-NC68_SB- STA 10+00
-NC68_NB- STA 10+00



PROJ. REFERENCE NO. R-2413CA SHEET NO. TMP-25

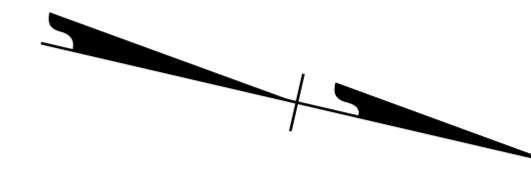

DENOTES WEDGING

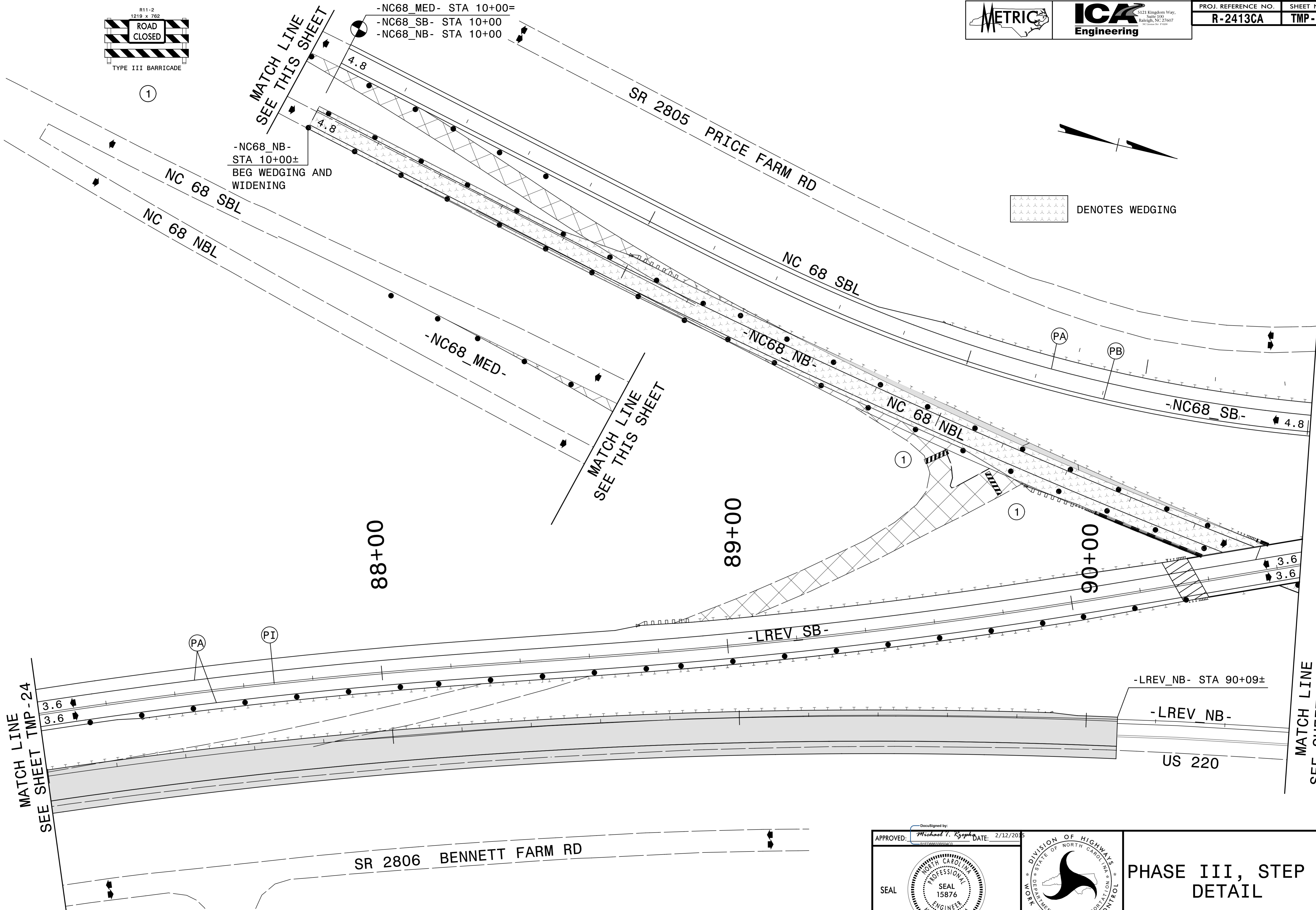

MATCH LINE
SEE SHEET TMP-24

MATCH LINE
SEE SHEET TMP-26

2/11/2015
E:\Traffic\TrafficControl\TCP\2413ca_tcp_pll1_s2.dtl_22.dgn
Florence & Hutchison, Inc.

APPROVED: *Michael T. Rzepka* DATE: 2/12/2015

DocuSigned by:
Michael T. Rzepka

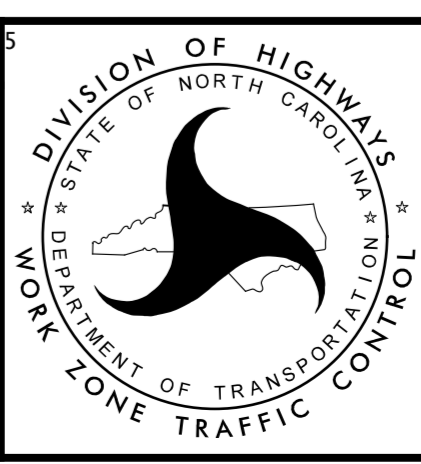

PHASE III, STEP 2
DETAIL

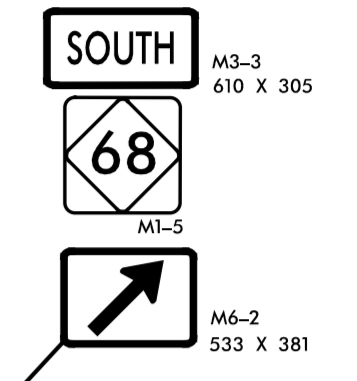
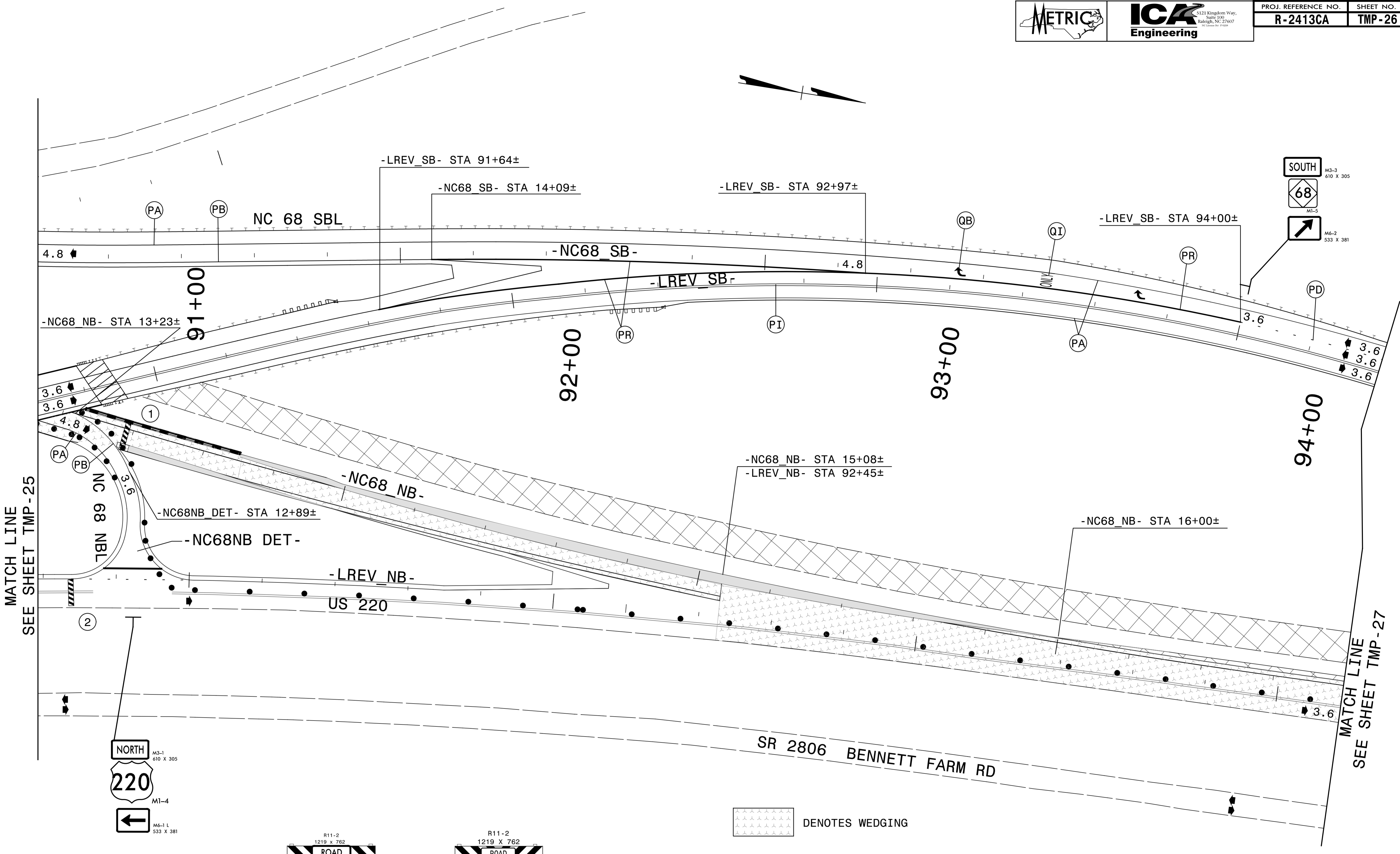

MATCH LINE
SEE SHEET TMP-25

MATCH LINE
SEE SHEET TMP-27

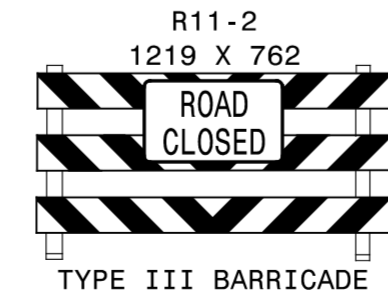
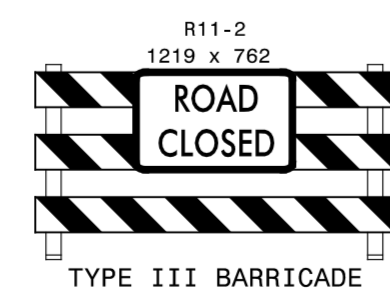
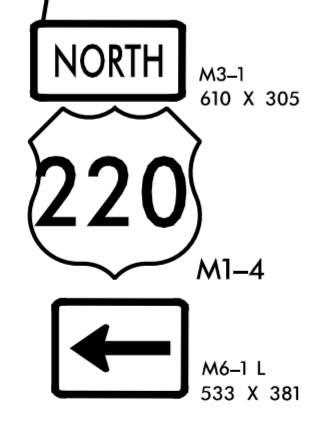

DENOTES WEDGING

APPROVED: *Michael T. Rzepka* DATE: 2/12/2015

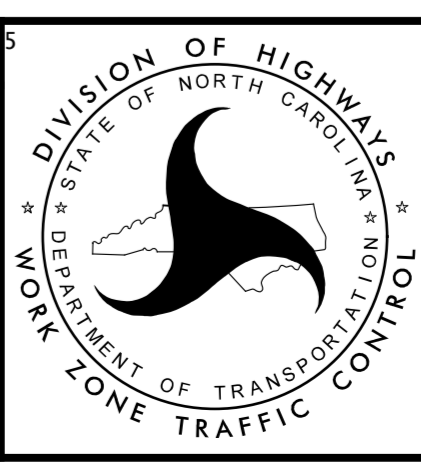

PHASE III, STEP 2
DETAIL

2/12/2015 R:\TratFig\TrafficControl\TCP\2413ca_tcp_pliil_s2.dtl_23.dgn Florence & Hutchison, Inc.

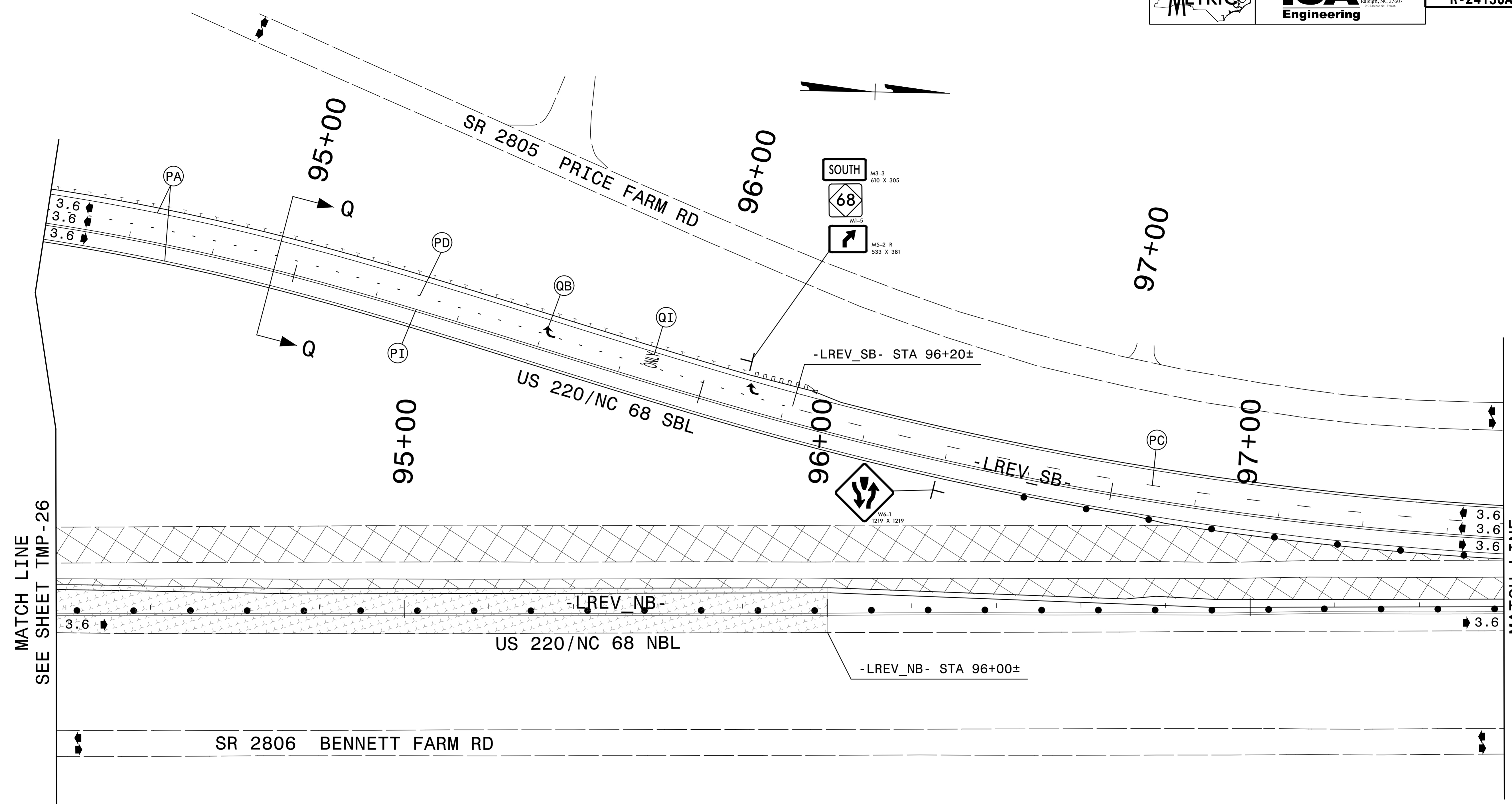

MATCH LINE
SEE SHEET TMP-26

MATCH LINE
SEE SHEET TMP-28

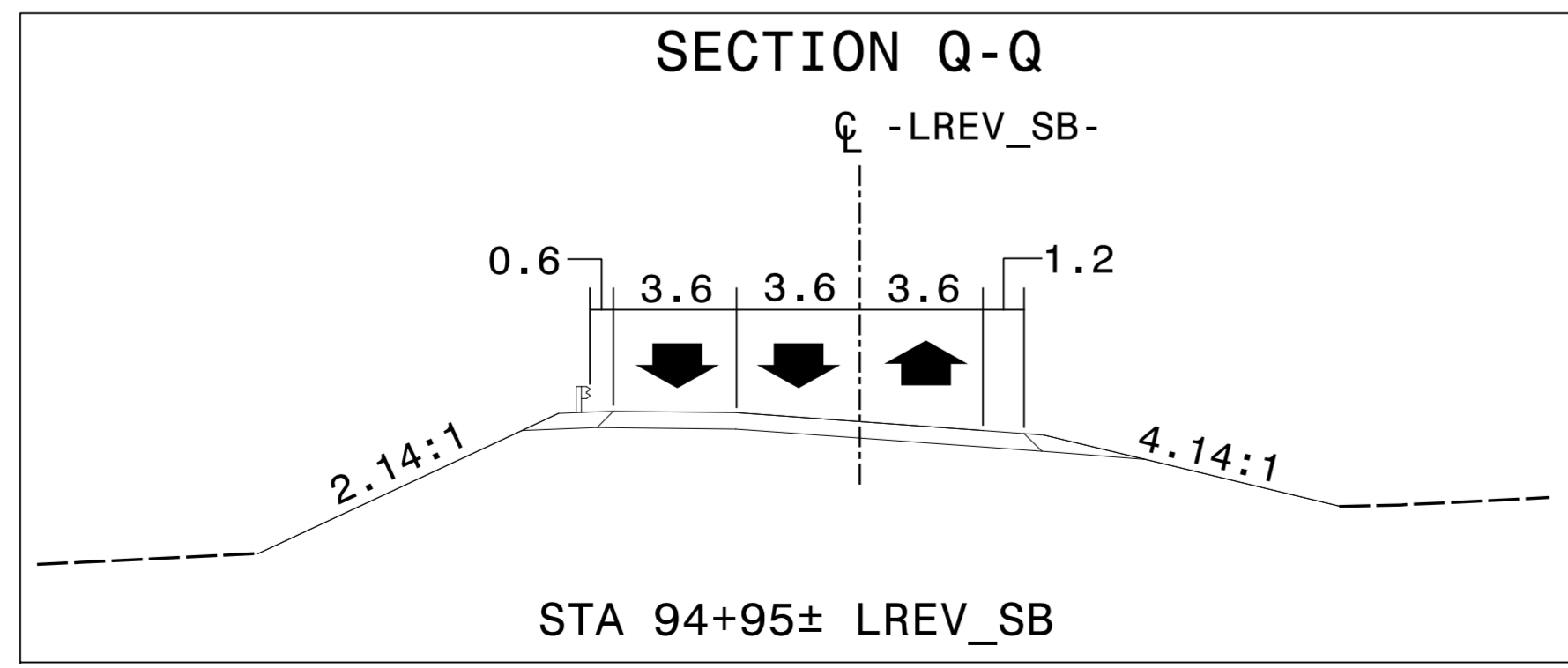

 DENOTES WEDGING

APPROVED: *Michael T. Rzepka* DATE: 2/12/2015
 DocuSigned by: Michael T. Rzepka

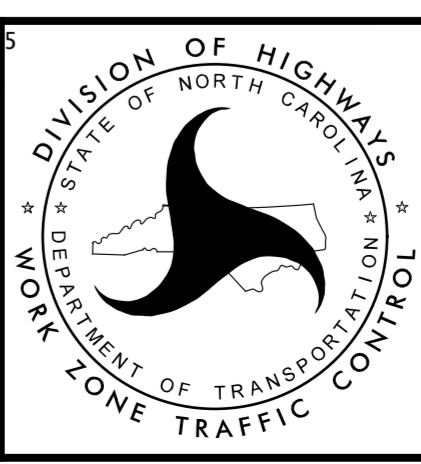

PHASE III, STEP 2
DETAIL

2/11/2015
 R:\Traffic\TrafficControl\TCP\2413ca_tcp_p111_s2.dtl_23a.dgn
 Florence & Hirschman, Inc.

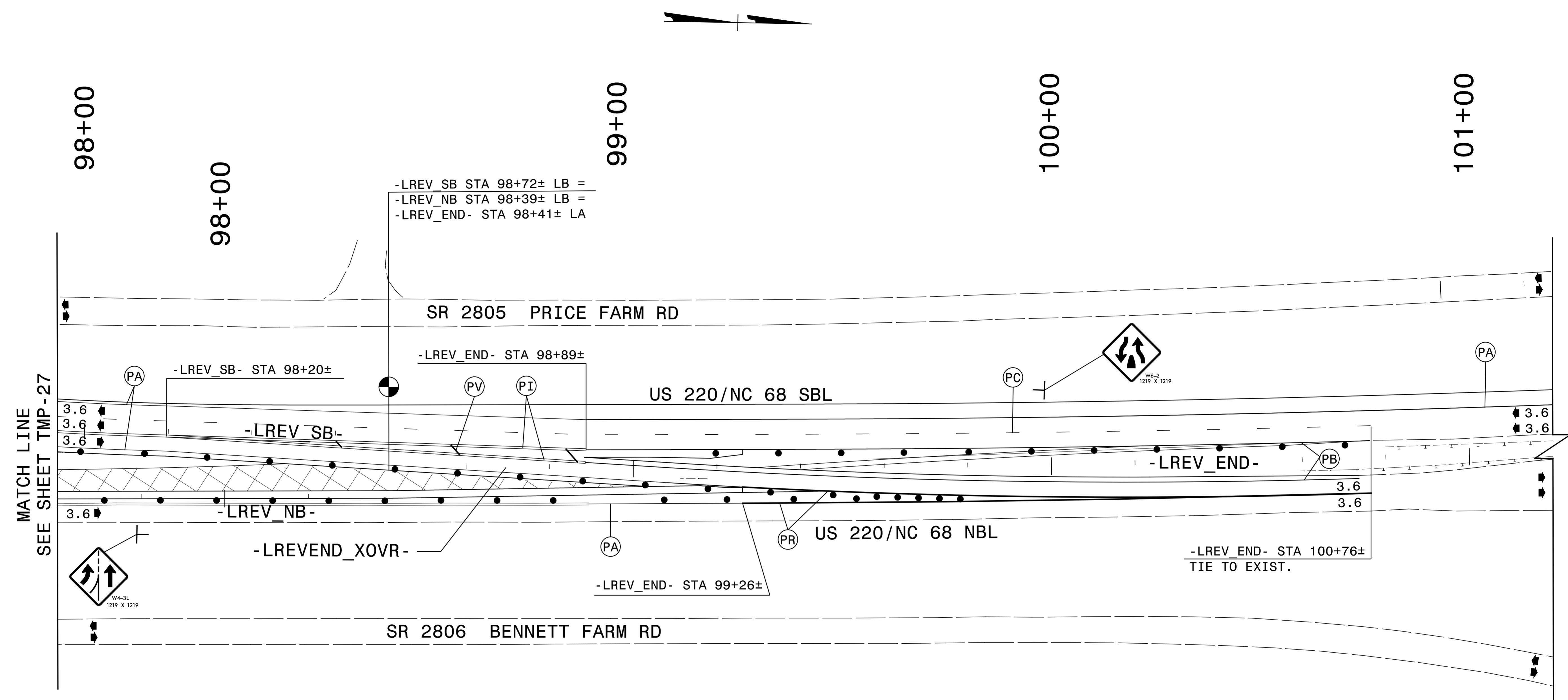
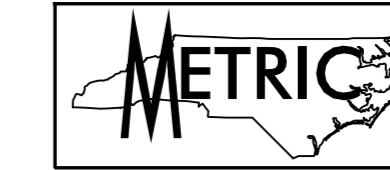

MATCH LINE
SEE SHEET TMP-27

2/11/2015
E:\Traffic\TrafficControl\TCP\2413ca_tcp_plt.s2_dtl_23b.dgn
Florence & Hutchison, Inc.

APPROVED: *Michael T. Rzepka* DATE: 2/12/2015

DocuSigned by:
Michael T. Rzepka

SEAL

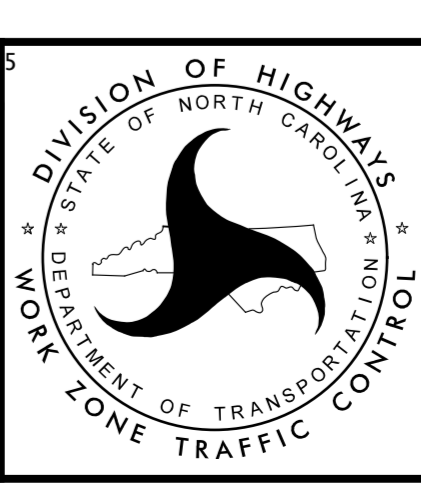

PHASE III, STEP 2
DETAIL

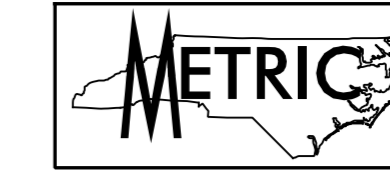

PROJ. REFERENCE NO.	SHEET NO.
R-2413CA	TMP-29

-NC68_MED- STA 10+00=
 -NC68_SB- STA 10+00
 -NC68_NB- STA 10+00

MATCH LINE
SEE THIS SHEET

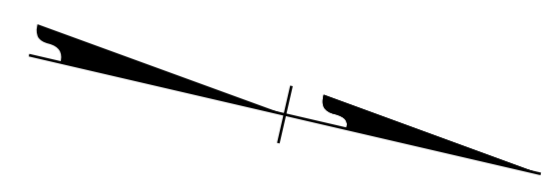

SR 2805 PRICE FARM RD

NC 68 SBL

NC 68 NBL

NC 68 SBL

NC 68 NBL

-NC68_MED-

MATCH LINE
SEE THIS SHEET

-NC68_SB-

-NC68_NB-

88+00

89+00

90+00

4.8

4.8

3.6

3.6

DENOTES WEDGING

-LREV_SB-

3.6

3.6

US 220

-LREV_NB-

-LREV_NB- STA 90+09±
 BEGIN WEDGING AND WIDENING

MATCH LINE
SEE SHEET TMP-30

SR 2806 BENNETT FARM RD

APPROVED: *Michael T. Rzepka* DATE: 2/12/2015

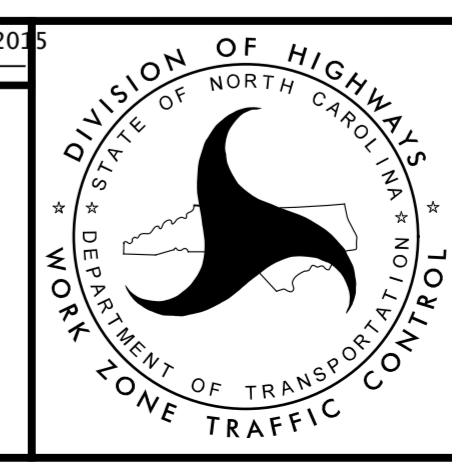
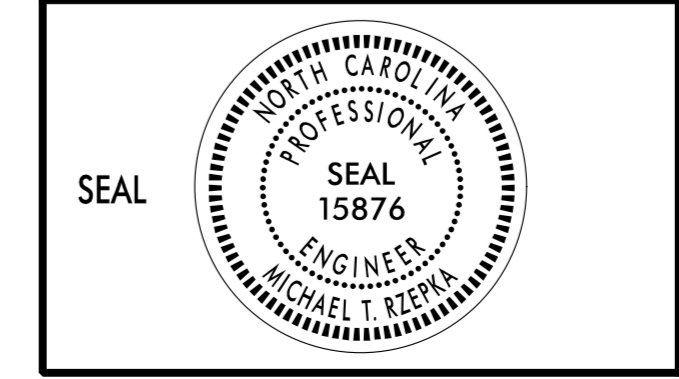

PHASE III, STEP 3
 DETAIL

2/11/2015
 R:\Traffic\TrafficControl\TCP\2413ca_tcp_p111_s3_dtl_22.dgn
 Florence & Hutchison, Inc.

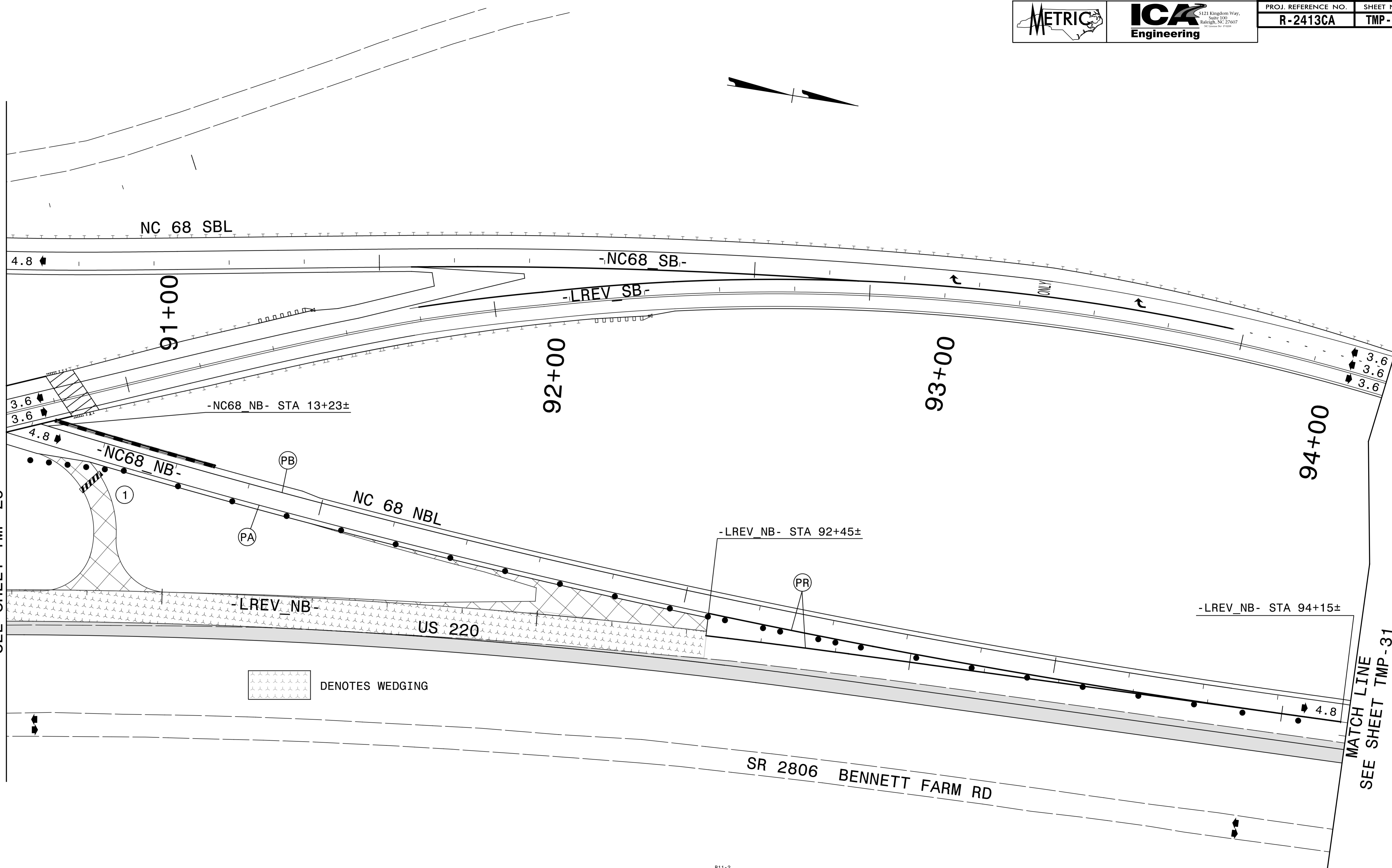

MATCH LINE
SEE SHEET TMP-29

MATCH LINE
SEE SHEET TMP-31

DENOTES WEDGING

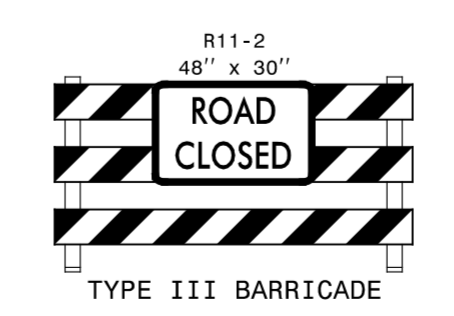

①

APPROVED: *Michael T. Rzepka* DATE: 2/12/2015

DocuSigned by:
Michael T. Rzepka

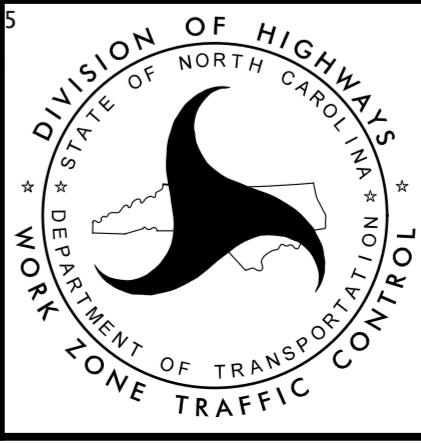

PHASE III, STEP 3
DETAIL

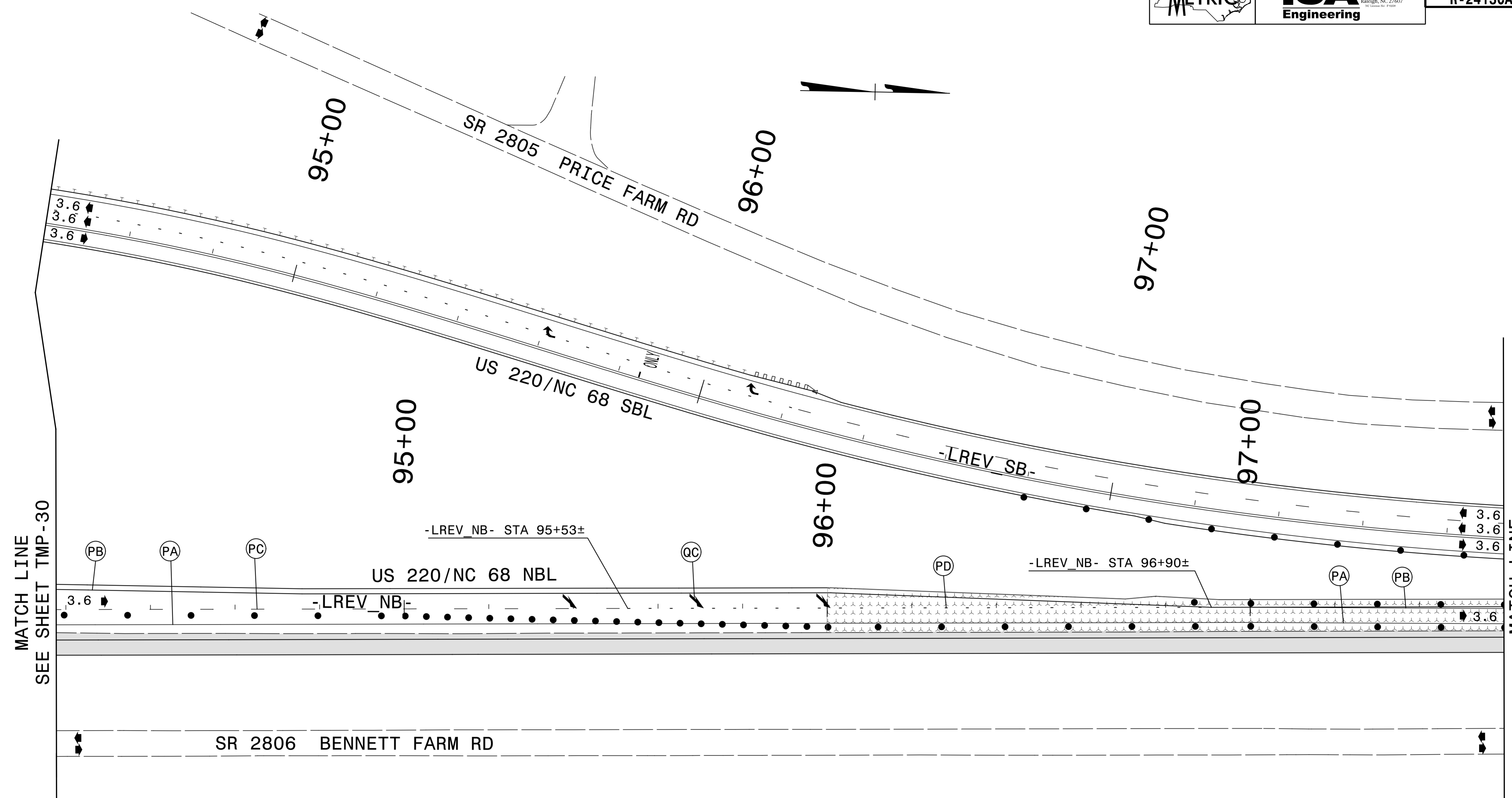

MATCH LINE
SEE SHEET TMP-30

MATCH LINE
SEE SHEET TMP-32

DENOTES WEDGING

2/11/2015
R:\Traffic\TrafficControl\TCP\2413ca_tcp_plt_s3.dtl_23a.dgn
Florence & Hutchison, Inc.

APPROVED: Michael T. Rzepka DATE: 2/12/2015

DocuSigned by:
Michael T. Rzepka

SEAL

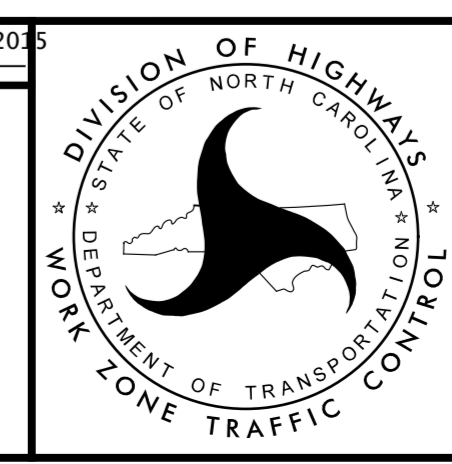

PHASE III, STEP 3
DETAIL

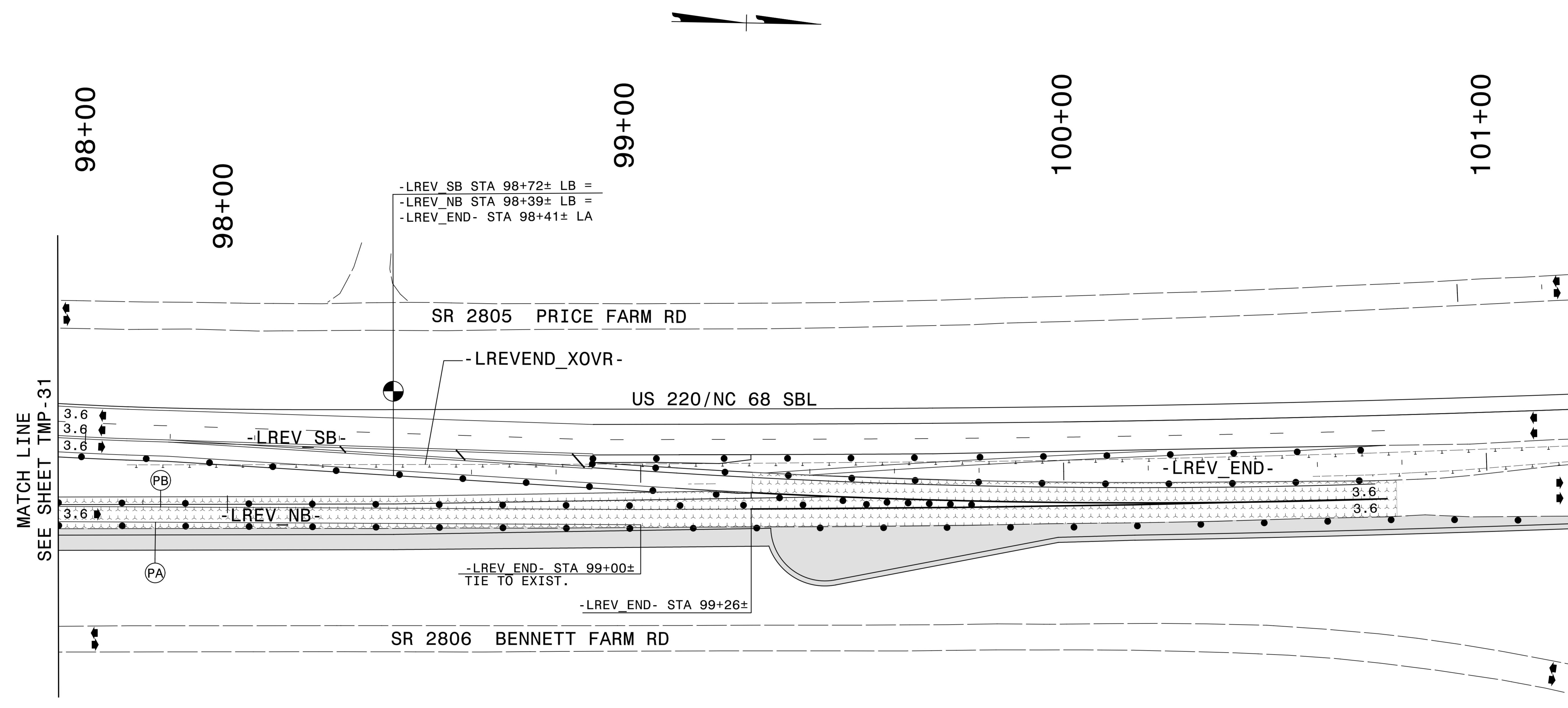
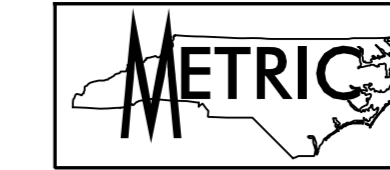

 DENOTES WEDGING

2/11/2015
 R:\Traffic\TrafficControl\TCP\2413ca_tcp_plt.s3_dtl_23b.dgn
 Florence & Hutchison, Inc.

APPROVED: Michael T. Rzepka DATE: 2/12/2015

DocuSigned by:
 Michael T. Rzepka

SEAL

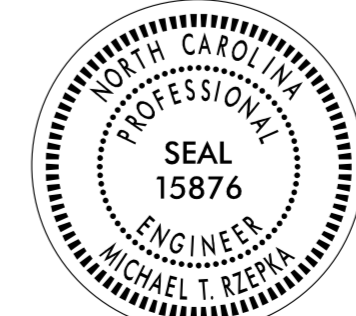
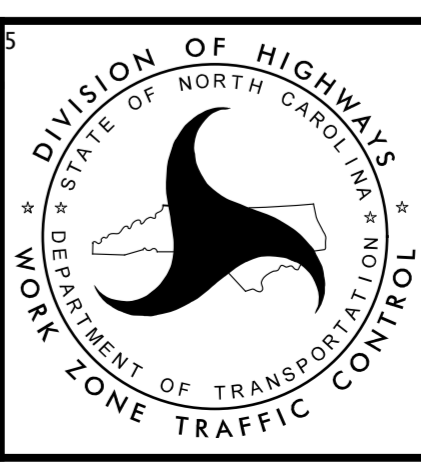
PHASE III, STEP 3
 DETAIL



PROJ. REFERENCE NO.	SHEET NO.
R-2413CA	TMP-33

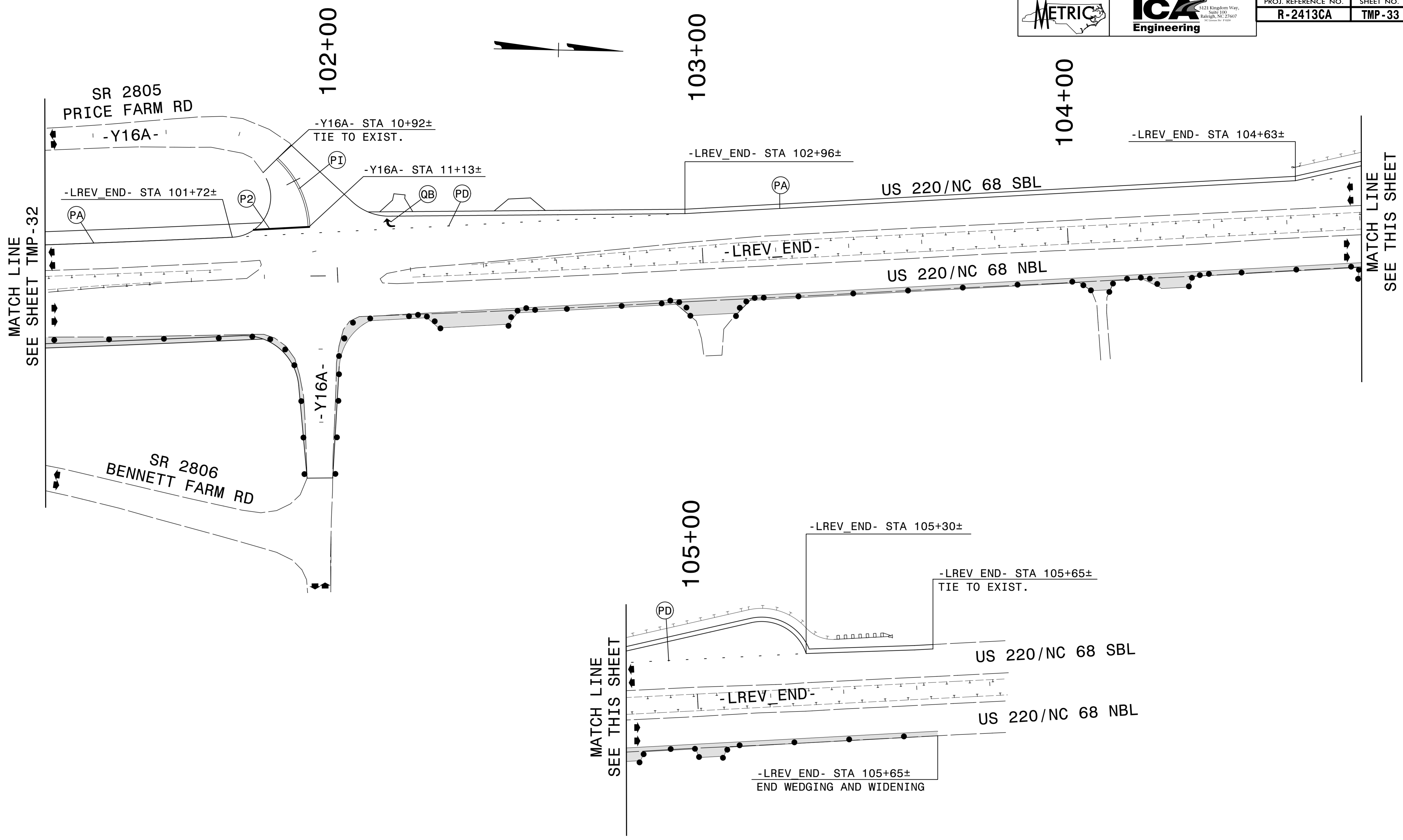

2/11/2015
 R:\Traffic\TrafficControl\TCP\2413ca_tcp_plt.s3.dtl_23c.dgn
 Florence & Hutchison, Inc.

APPROVED: *Michael T. Rzepka* DATE: 2/12/2015

DocuSigned by:
Michael T. Rzepka

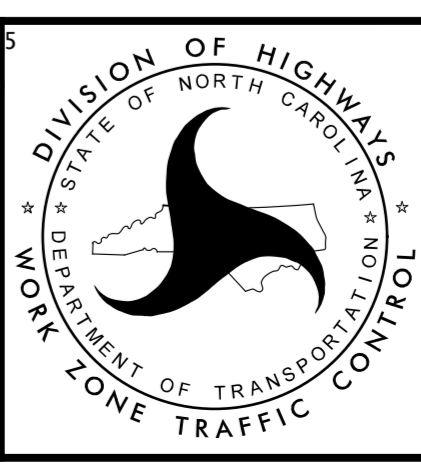

PHASE III, STEP 3
DETAIL

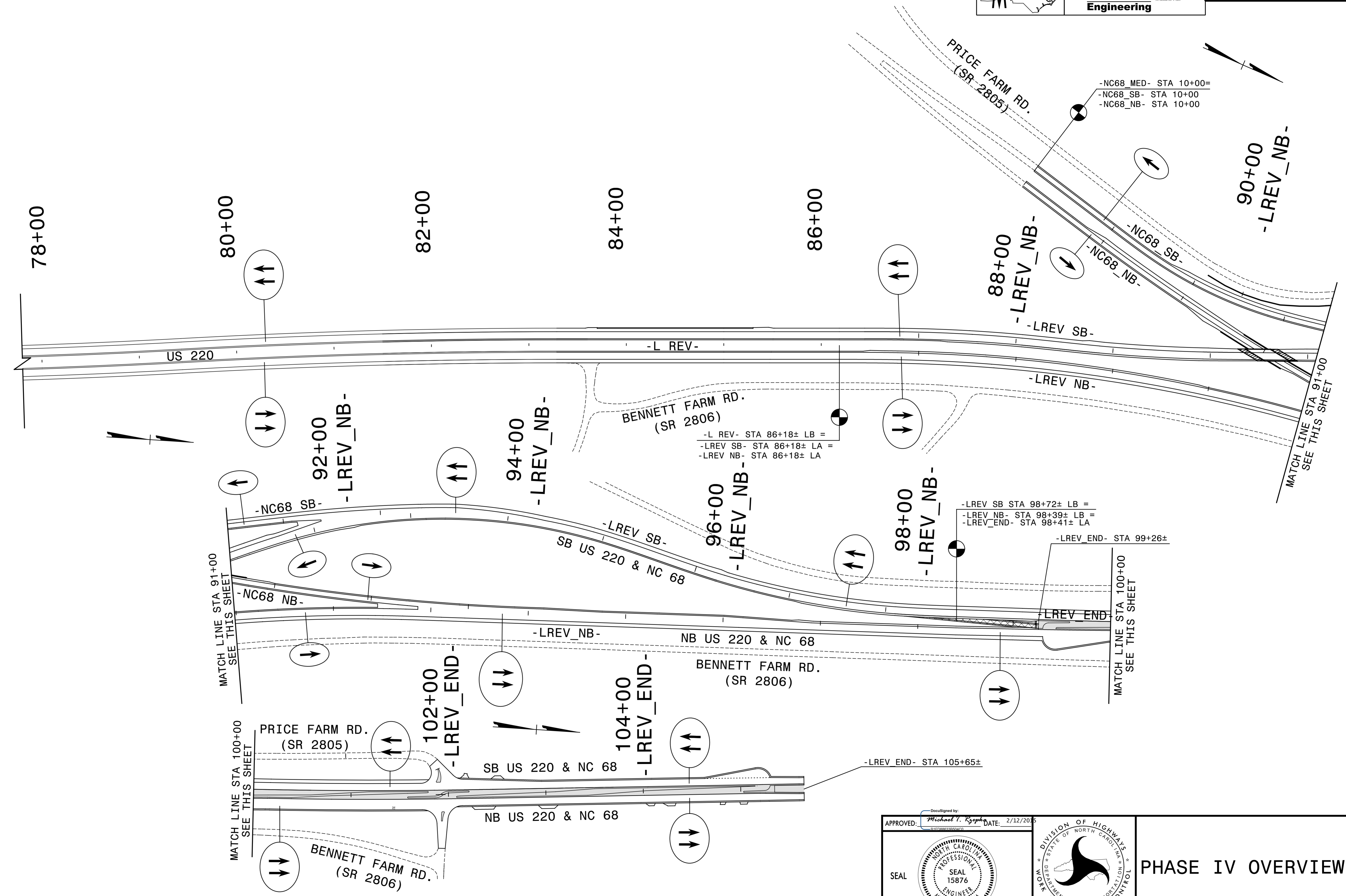

2/12/2015
 R:\Trat\Fig\Trat\FigCont\Tol\TCP\2413ca_tcp_piv_ovw_e.dgn
 Florence & Hutchison, Inc.

APPROVED: *Michael T. Rzepka* DATE: 2/12/2015

DocuSigned by:
Michael T. Rzepka

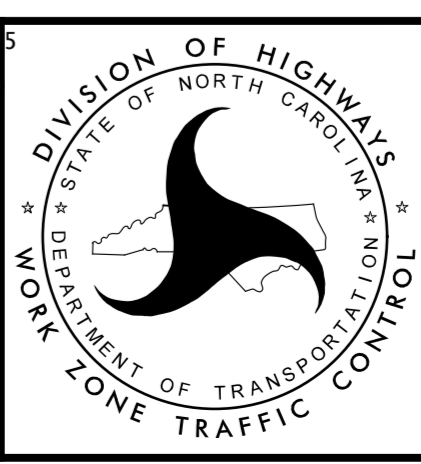

PHASE IV OVERVIEW