

WIRING DETAIL FOR NORTHSTAR CONTROLS NQ4 LONG VEHICLE / OVERSPEED DETECTION SYSTEM NO. 2  
(wire unit as shown below)

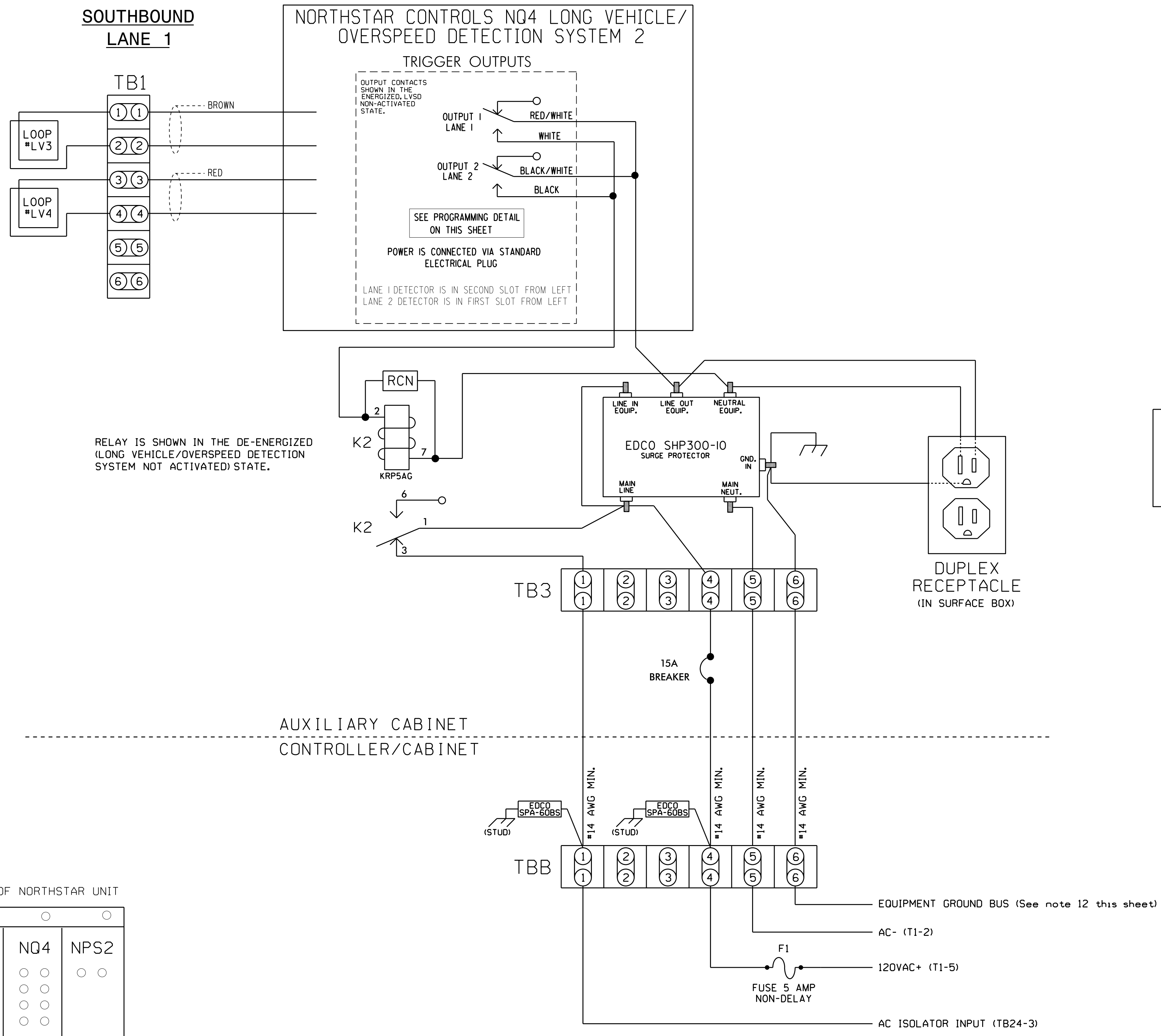

NOTES

1. All loop lead-ins shall be twisted.
2. Loop spacing is critical to the proper operation of this Overspeed Detection System. Make sure loop spacing is correctly programmed in NQ4 Unit.
3. Insure that connectors on rear of NQ4 are seated securely.
4. NQ4 Unit shall be located in an auxiliary cabinet adjacent to Speed Warning System Loops.
5. Unit power is connected by standard electrical plug.
6. Terminal strips TB1, TB2, TB3, & TBB to be added by installer.
7. Relay 'K2' is a SPDT with an 120VAC coil. Potter & Brumfield no. KRP5AGAG, Dot Material no. 625028600.
8. The RC Network across the coil of 'K2' is a .1 micro farad, 100 ohm. Dot Material no. 106018075. P&B no. 104M060C100
9. EDCO SPA-60BS is a surge protector for 120VAC interconnect circuits. Dot Material no. 625022076.
10. EDCO SHP300-10 is an AC service surge protector. Dot Material no. 625022075.
11. Do not install ground rods at auxiliary cabinet.
12. Install equipment ground from controller cabinet to auxiliary cabinet if not already present.
13. Install disconnect if there is no disconnect present at auxiliary cabinet.

**NORTHSTAR CONTROLS MODEL NQ4 PROGRAMMING DETAIL**  
(program unit as shown)

NOTE: UNIT MUST BE PROGRAMMED USING PC AND HYPERTERMINAL PROGRAM. FOR CONNECTION TO HYPERTERMINAL REFER TO NQ4 OPERATION MANUAL.

PROGRAM NQ4 BY TYPING THE FOLLOWING COMMANDS

1. SET SPEED=55
2. SET LENGTH=22'
3. SET ALARMTIME=12
4. SET SEPARATION=27' (LEADING EDGE TO LEADING EDGE)  
(THIS VALUE MAY VARY, PROGRAM ACTUAL MEASURED SEPARATION)
5. SET LOOP LENGTH=6'  
(THIS VALUE MAY VARY, PROGRAM ACTUAL MEASURED LOOP LENGTH)
6. SAVE

NOTE  
PROGRAMMING APPLIES TO LANE 1

FRONT VIEW OF NORTHSTAR UNIT

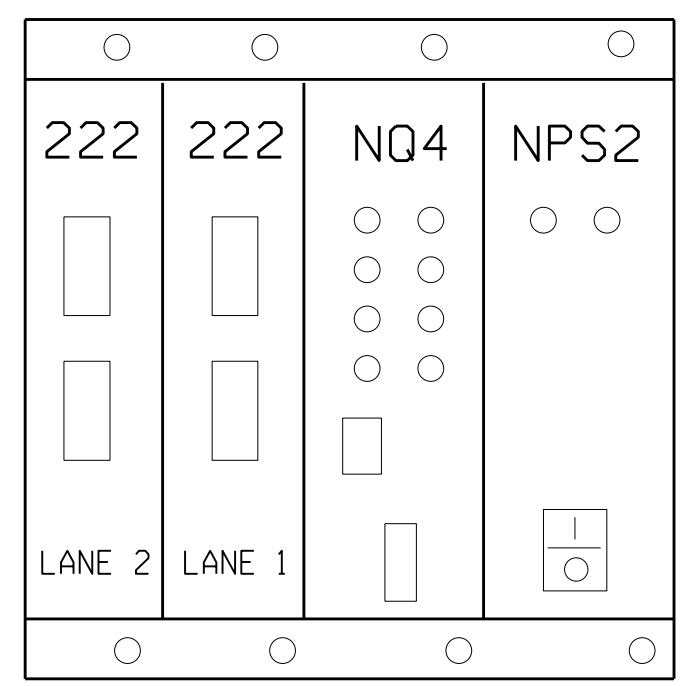

THIS ELECTRICAL PLAN SUPERSEDES THE PLAN ORIGINALLY SEALED ON 8/19/11.

THIS ELECTRICAL DETAIL IS FOR THE SIGNAL DESIGN: 07-0282  
DESIGNED: January 2015  
SEALED: 1/27/2015  
REVISED: N/A

Electrical Detail - Temporary Signal (TMP Phase I) - Sheet 4 of 4

<p>Electrical and Programming Details For:</p> <p>750 N. Greenfield Pkwy, Garner, NC 27529</p>	<p>US 220 at NC 68</p>		<p>SEAL</p>
	<p>Division 7 Rockingham County NE of Stokesdale</p>	<p>DATE: January 2015 REVIEWED BY: JTR</p>	
<p>PREPARED BY: S. Armstrong</p>		<p>REVIEWED BY:</p>	
<p>REVISIONS</p>	<p>INIT.</p>	<p>DATE</p>	<p>DocuSigned by: John T. Rowe, Jr. 1/28/2015</p>
<p>SIG. INVENTORY NO. 07-0282</p>			<p>DATE</p>

07-0282-0015-15.dgn  
 C:\IT\SSM\TSS\Sigma\work\proj\070282\_sim.eia\_xxx.dgn  
 somstr.dgn