

RAILROAD PREEMPTION PROGRAMMING DETAIL

(program controller as shown below)

From Main Menu press 'A' (Preemption), then '1' (Standard Preemptions).

PREEMPTION #1	SETTINGS (NEXT:1-10)
INTERVAL/TIMING	CLEAR/DWELL PHASES
GRN YEL RED	12345678910111213141516
1 10 3.8 1.8	X
2 255 0.0 0.0	X X
3 0 0.0 0.0	
4 0 0.0 0.0	
5 1 0.0 0.0	X
EXIT CALLS	
OPTIONS	
PRIORITY (Y/N TO SELECT)HIGH
DELAY TIMER (0-255 SEC)0
MIN GREEN BEFORE PRE (0= DEFAULT)	...1
PED CLEAR BEFORE PRE (0= DEFAULT)	...0
YELLOW CLEAR BEFORE PRE (0= DEFAULT)	...0
RED CLEAR BEFORE PRE (0= DEFAULT)	...0
DWELL MIN TIMER (0-255 SEC)10
DWELL MAX TIMER (0=OFF,1-255MIN)	...0
DWELL HOLD-OVER TIMER (0-255)0
LATCH CALL?N
LINK TO NEXT PREEMPT?N
ENABLE BACKUP PROTECTION?N
HOLD CLEAR 1 PHASES DURING DELAY?	...N
FAST GREEN FLASH DWELL PHASES?N
PED CLEARANCE THROUGH YELLOW?N
INHIBIT OVERLAP GREEN EXTENSION?N
SERVICE DURING SOFTWARE FLASH?N
REST IN RED DURING DWELL INTERVAL?	...N
FLASH DWELL INTERVAL?N
ALLOW PEDS IN DWELL INTERVAL?N
RE-TIME DWELL INTERVAL?N
OVERLAPS:	ABCDEFGHIJKLMN
DWELL INT FLASH YELLOW	
OMIT OVERLAPS:	X

PREEMPT 1 AC ISOLATOR (MODEL 252) OUTPUT PROGRAMMING DETAIL

(set DIP switches as shown below)

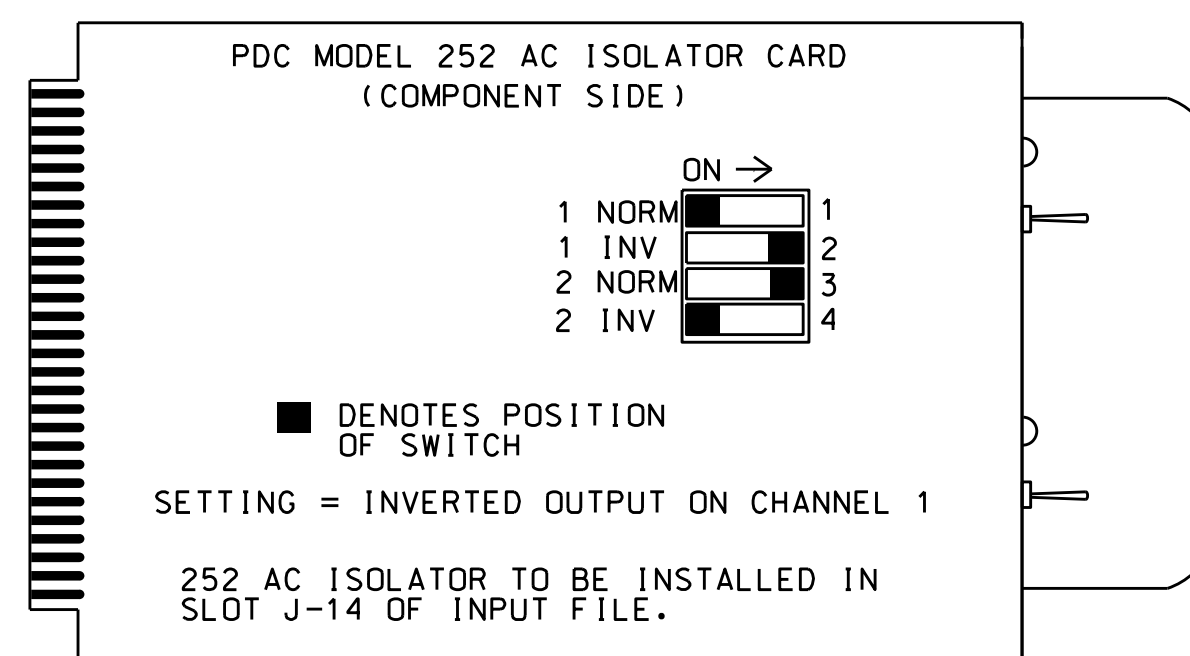

NOTE: IF ANOTHER MANUFACTURER TYPE OF AC ISOLATOR IS USED, OUTPUT PROGRAMMING IS LIKELY NOT TO EQUATE TO THAT SHOWN ABOVE.

RAILROAD PREEMPTION WIRING DETAIL

(wire as shown below)

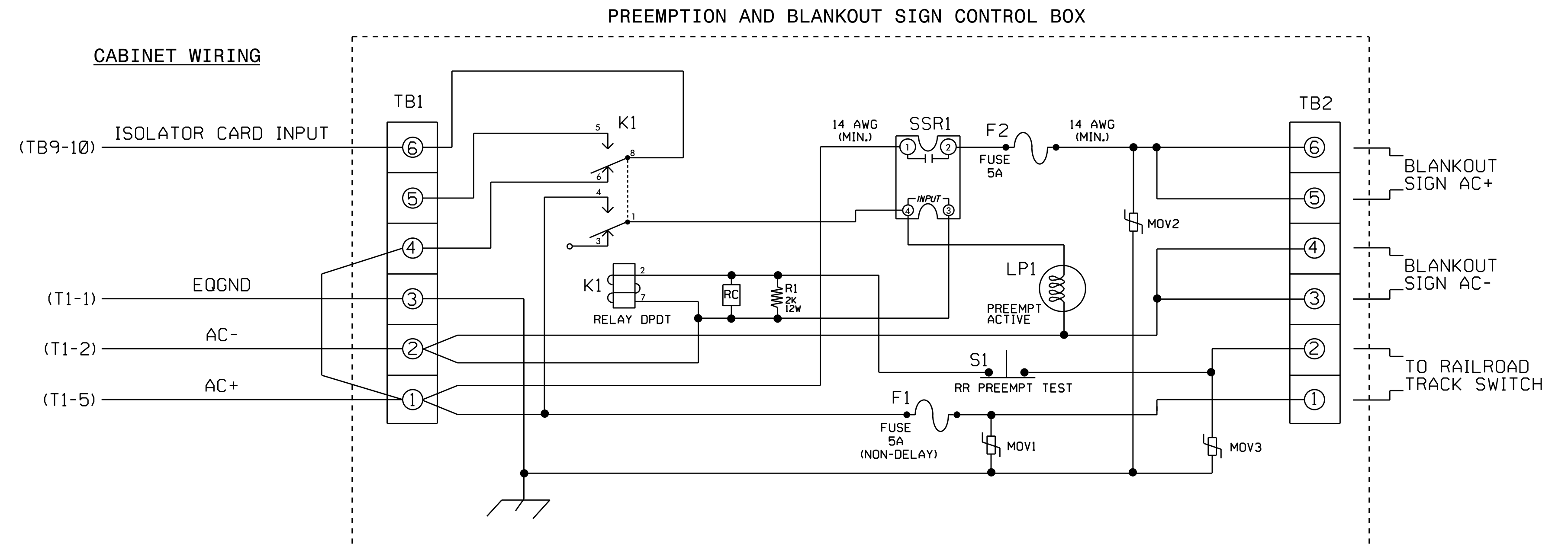

NOTES

- Relay K1 is shown in the energized (Preempt not active) normal operation state.
- Relay K1 is a DPDT with 120VAC coil with octal base.
- Relay SSR1 is a SPST (normally open) Solid State Relay with AC input and AC (25 amp) output.
- AC Isolator Card shall activate preemption upon removal of AC+ from the input (as shown above). To accomplish this set invert dip switch on AC Isolator Card.
- IMPORTANT!!** A jumper must be added between input file terminals J14-E and J14-K if not already present. Also, terminal TB9-12 (on input panel) shall be connected to AC neutral (jumper may have to be added).

FRONT VIEW

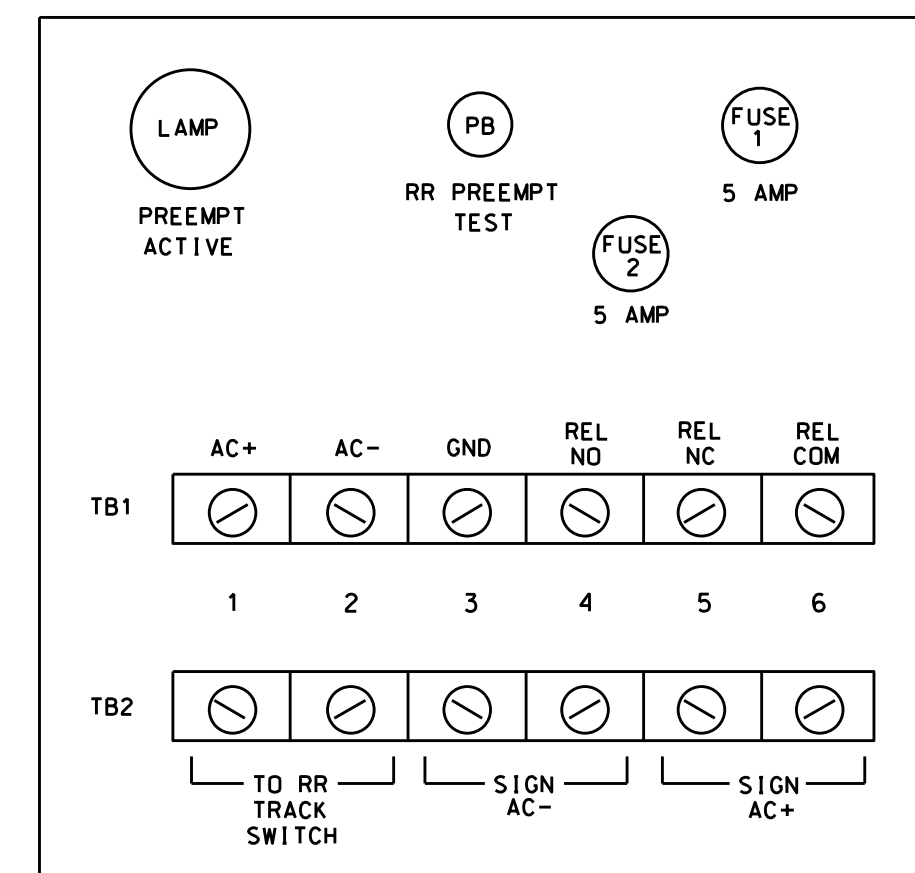

Electrical Detail - Sheet 3 of 3

THIS ELECTRICAL DETAIL IS FOR THE SIGNAL DESIGN: 08-0313
DESIGNED: February 2015
SEALED: 2/19/2015
REVISED: N/A

	DETAILS FOR: SR 1619 (Prospect Street) at I-85 Bus/US 29 SB-70 WB Ramp and SR 1621 (Bethel Dr.)		SEAL
	Prepared In the Offices of: S. ARMSTRONG Signal Management Station 750 N. Greenfield Pkwy, Garner, NC 27529	Division 8 Randolph County High Point PLAN DATE: February 2015 REVIEWED BY: JTR PREPARED BY: S. Armstrong REVIEWED BY:	
REVISIONS		INIT. DATE	SIG. INVENTORY NO. 08-0313

20-FEB-2015 08:47
 C:\PITS\SSM\TSS\Signal\work\hgr\coups\sig_Mgr\Armstrong\080313_sml.ele.xxx.dgn
 S.ARMSTRONG