

UTILITIES BY OTHERS

NOTE:
ALL PROPOSED UTILITY WORK SHOWN ON THIS SHEET WILL BE DONE BY OTHERS. NO PAYMENT WILL BE MADE TO THE CONTRACTOR FOR PROPOSED UTILITY WORK SHOWN ON THIS SHEET.

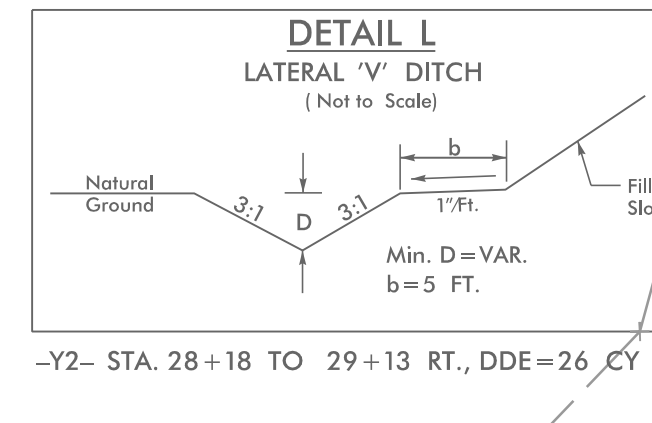
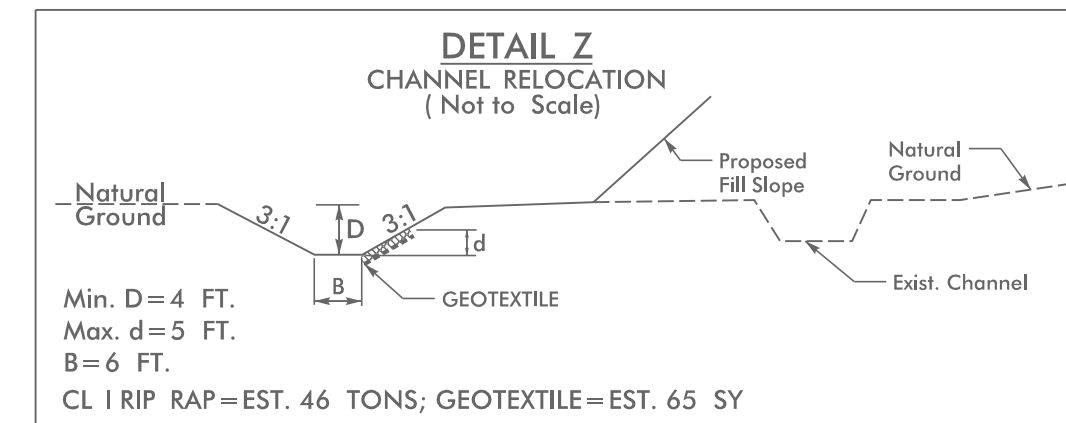
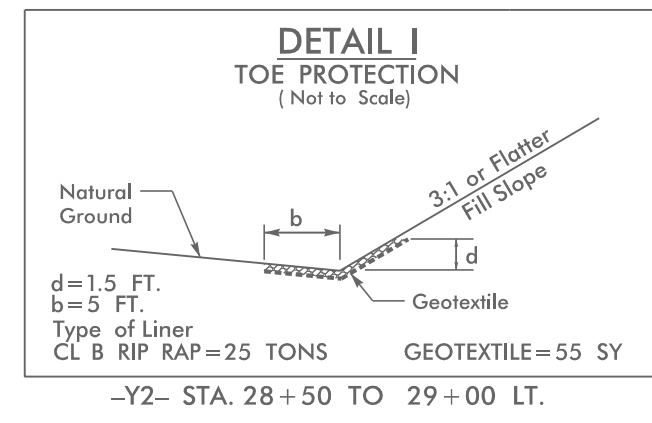
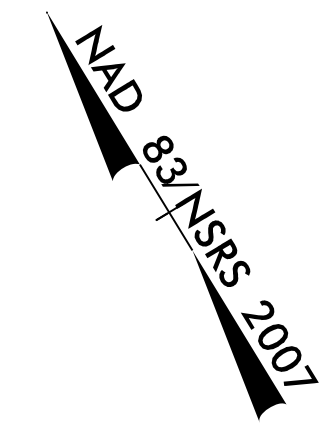

-Y2-
 $PI Sta. 33+27.72$
 $\Delta = 4' 54" 06.0" (LT)$
 $D = 2' 23" 14.4"$
 $L = 205.32'$
 $T = 102.72'$
 $R = 2,400.00'$

MATCHLINE UO 7 -Y2- STA. 28+50.00

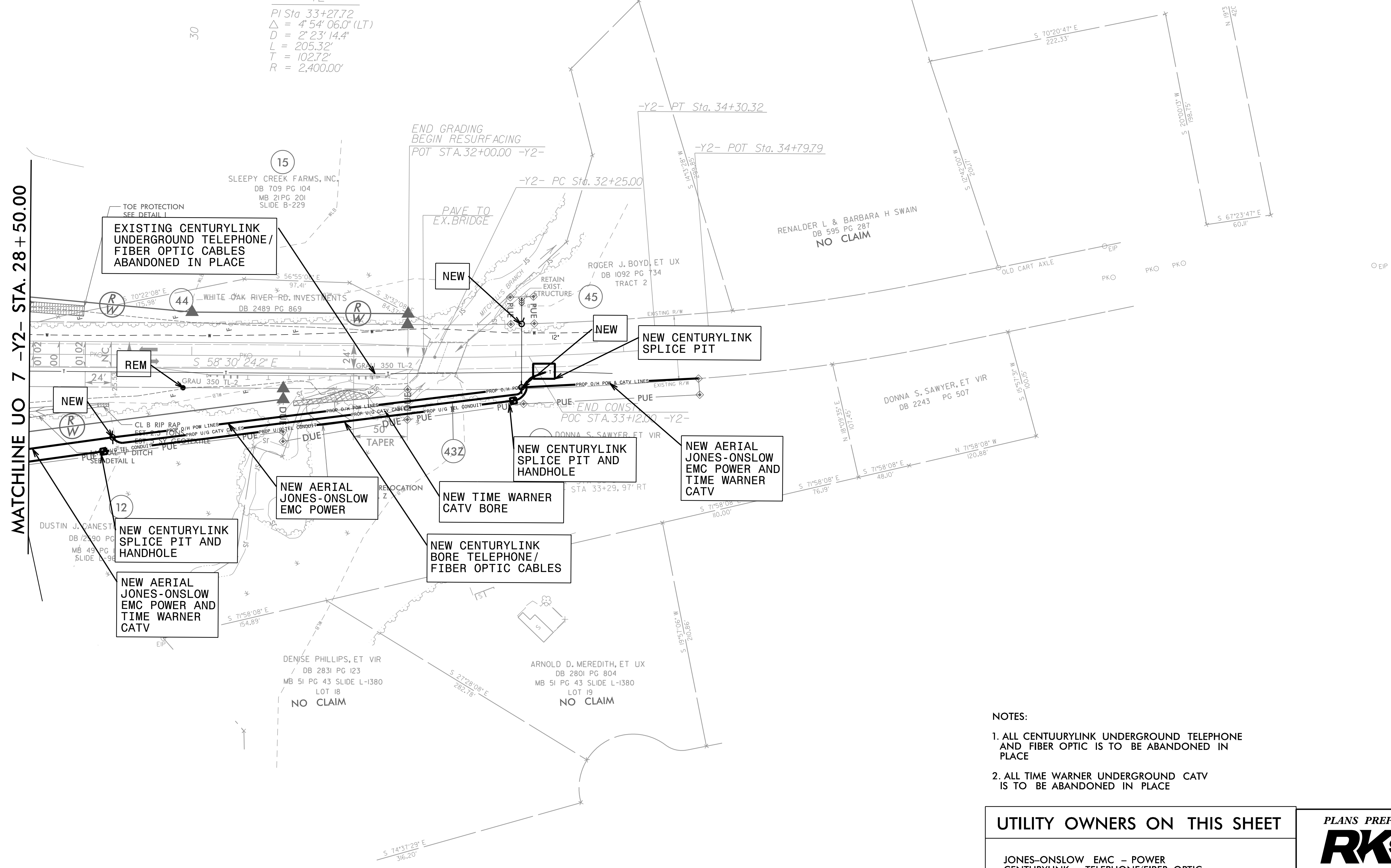

- NOTES:**
1. ALL CENTURYLINK UNDERGROUND TELEPHONE AND FIBER OPTIC IS TO BE ABANDONED IN PLACE
 2. ALL TIME WARNER UNDERGROUND CATV IS TO BE ABANDONED IN PLACE

<p>UTILITY OWNERS ON THIS SHEET</p> <p>JONES-ONSLow EMC - POWER CENTURYLINK - TELEPHONE/FIBER OPTIC TIME WARNER - CATV</p>	<p>PLANS PREPARED BY :</p> <p>RK&K</p> <p>RUMMEL, KLEPPER & KAHL, LLP 900 RIDGEFIELD DRIVE SUITE 350 RALEIGH, NORTH CAROLINA 27609-3960 NC LICENSE NO. F-0112 • (919) 878-9560</p>
---	--