

5/28/99

PROJECT REFERENCE NO. U-2524BC	SHEET NO. 12
ROADWAY DESIGN ENGINEER NORTH CAROLINA PROFESSIONAL SEAL 37950 4/20/2015	HYDRAULICS ENGINEER NORTH CAROLINA PROFESSIONAL SEAL 29984 4/16/2015

-RPA-

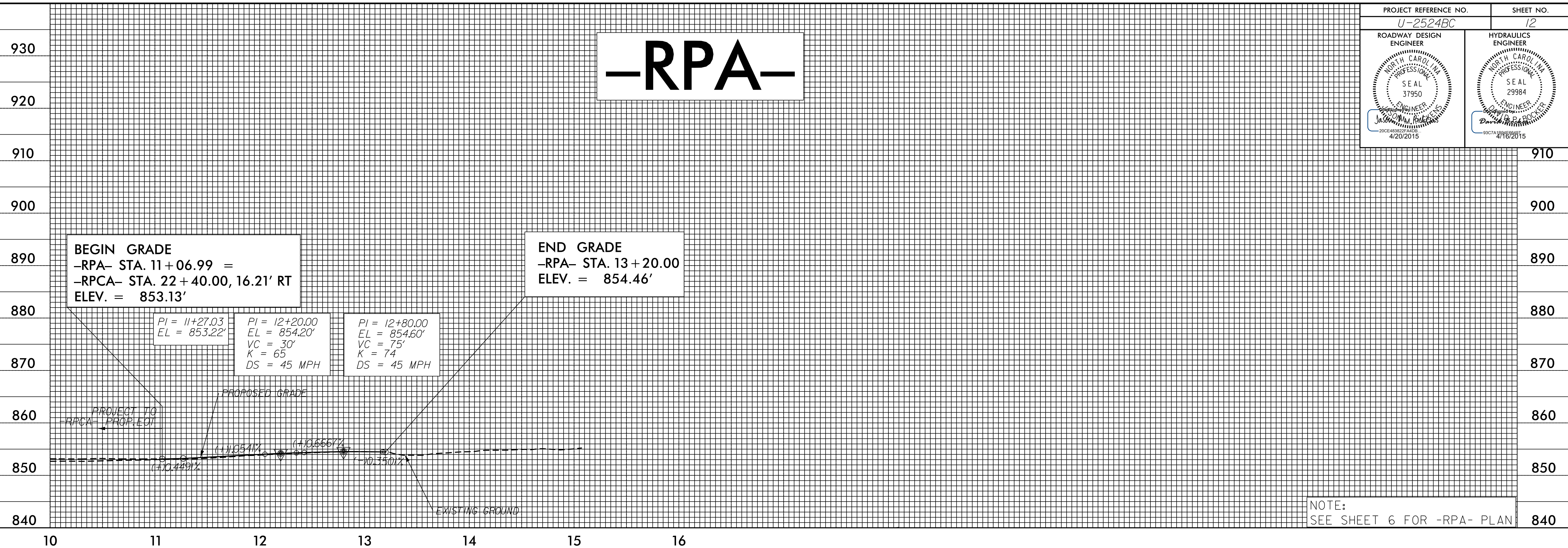

-Y-

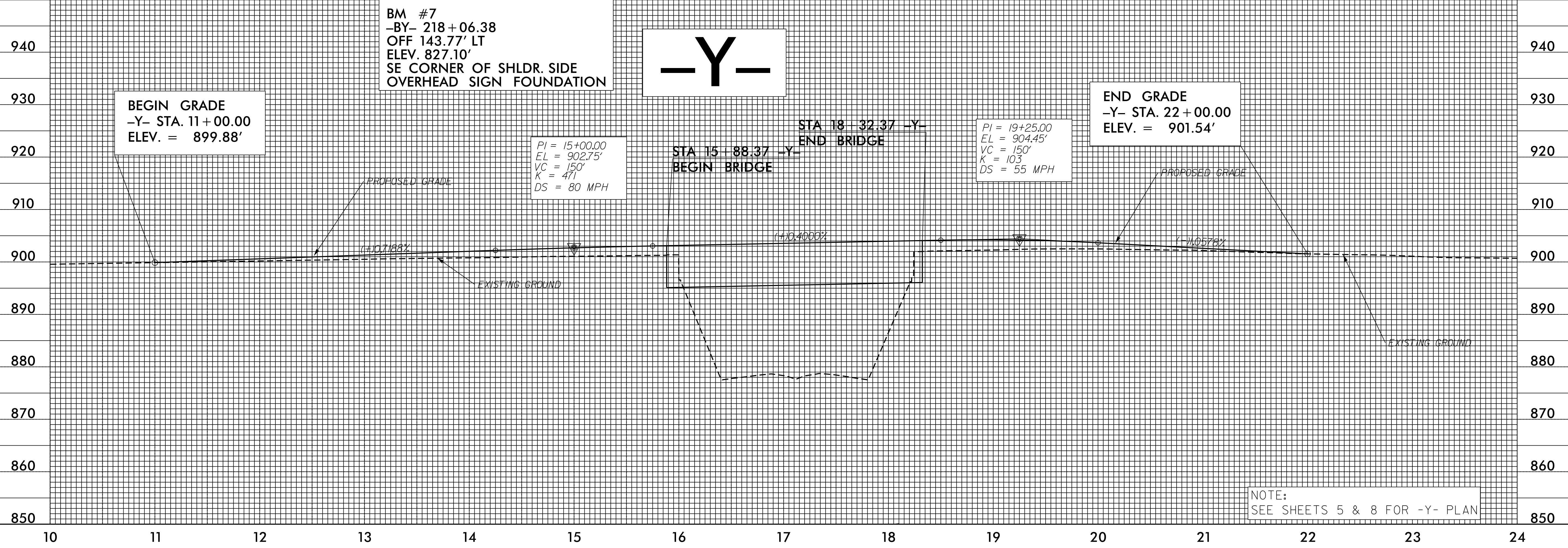

16-APR-2016 11:00 AM C:\Users\p\Documents\Projects\U2524BC\RDY_PFL_12.DGN