

POUR SEQUENCE

→ = INDICATES POUR NUMBER AND DIRECTION OF POUR
 NOTE: CONTRACTOR HAS THE OPTION TO COMBINE POURS 4 AND 5.

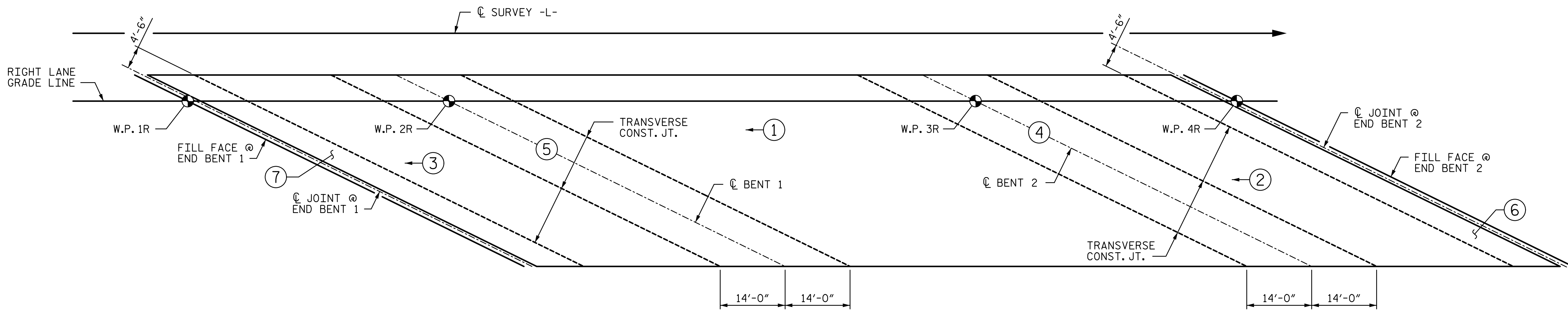

OPTIONAL POUR SEQUENCE

NOTE: CONTRACTOR HAS THE OPTION TO COMBINE POURS 6 AND 7.

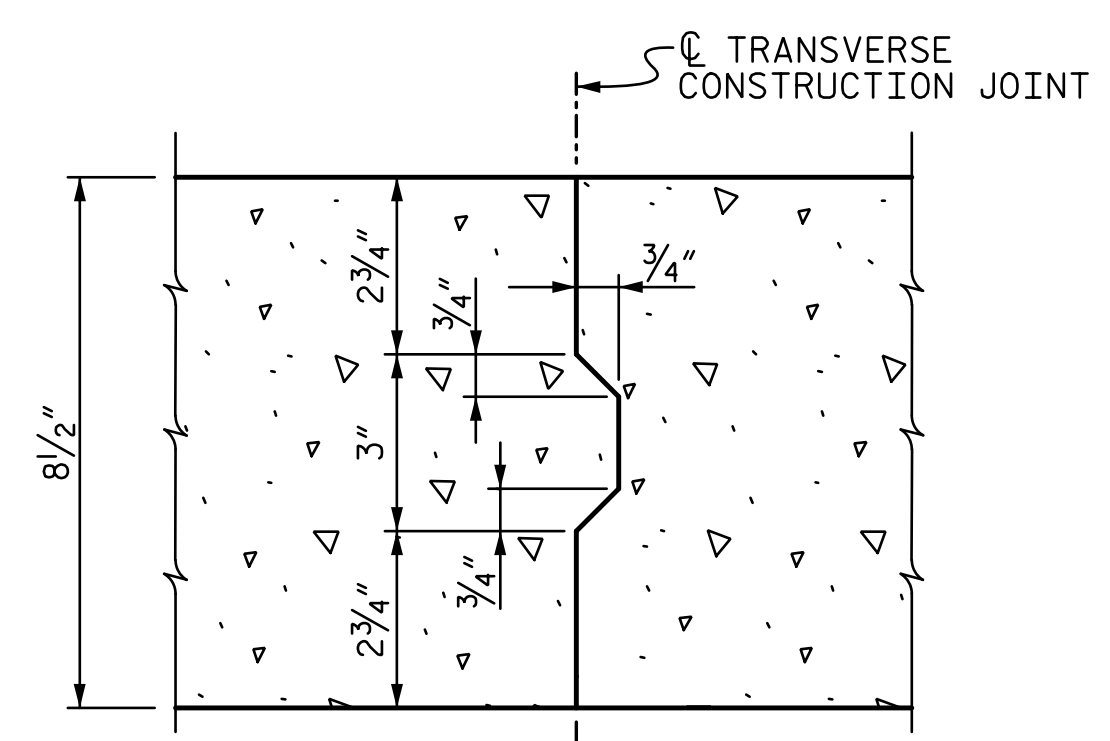

NOTE: REINFORCING STEEL IN SLAB NOT SHOWN. TRANSVERSE & LONGITUDINAL REINFORCING STEEL SHALL BE CONTINUOUS THROUGH JOINT.

CONSTRUCTION JOINT IN DECK SLAB

PROJECT NO. R-2514D
JONES & CRAVEN COUNTY
 STATION: 526+71.12 -L-
 = 16+08.07 -Y6-



STATE OF NORTH CAROLINA
 DEPARTMENT OF TRANSPORTATION
 RALEIGH
 SUPERSTRUCTURE
DECK POUR SEQUENCE
 -RIGHT LANE-

REVISIONS				SHEET NO.
NO.	BY:	DATE:	NO.	DATE:
1			3	
2			4	

TOTAL SHEETS: 38

R:\Site 6\usta\Finals\Site 6 RL\412_022_R2514D_SMU_DFS.dgn 9:08:42 AM 3/6/2015

DRAWN BY: CLG DATE: 6-14
 CHECKED BY: TJT DATE: 6-14
 DESIGN ENGINEER OF RECORD: A. PETER DATE: 6-14

STV / Ralph Whitehead Associates, Inc.
 900 West Trade Street, Suite 715
 Charlotte, NC 28202
 NC License Number F-0991