

PLAN

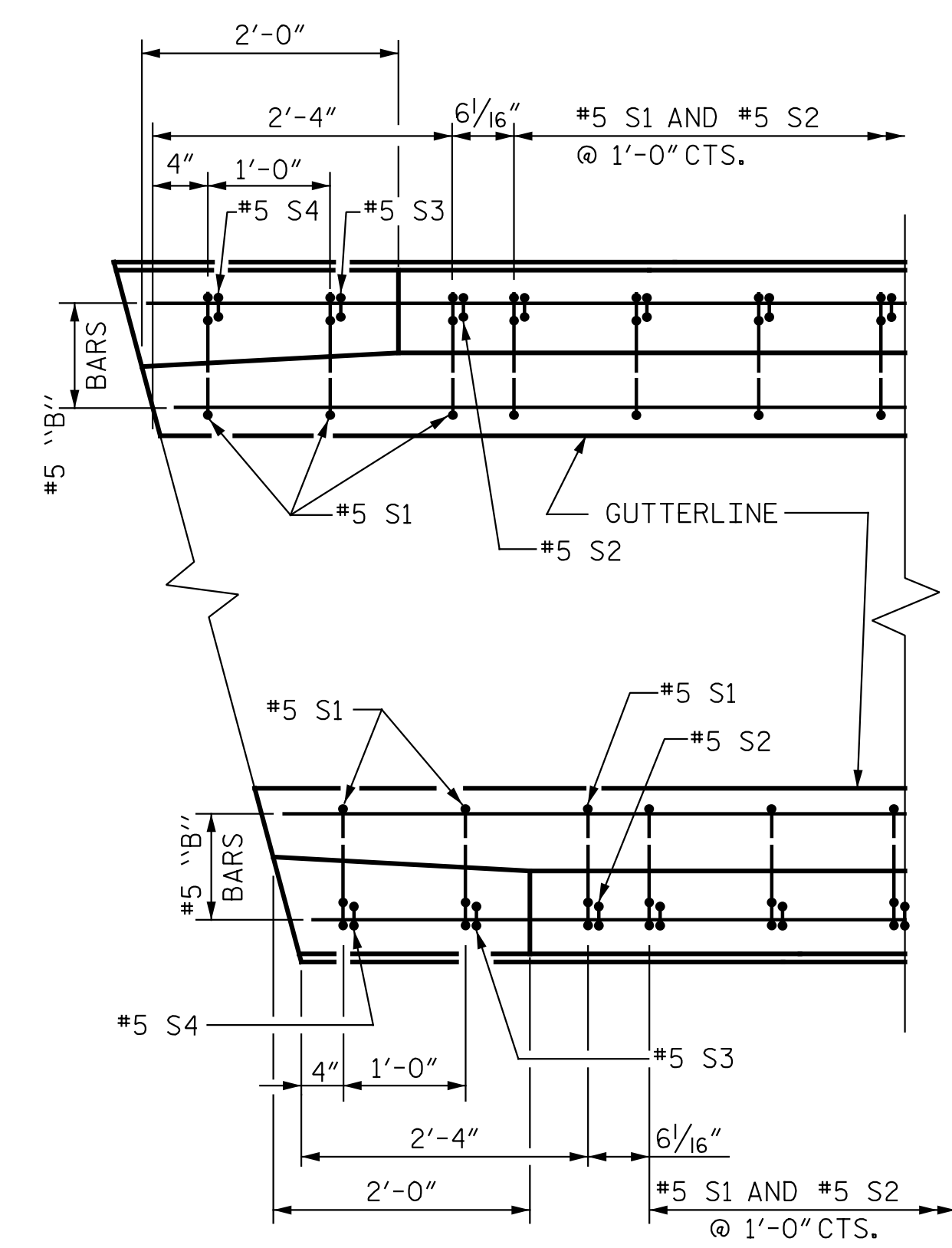

PLAN

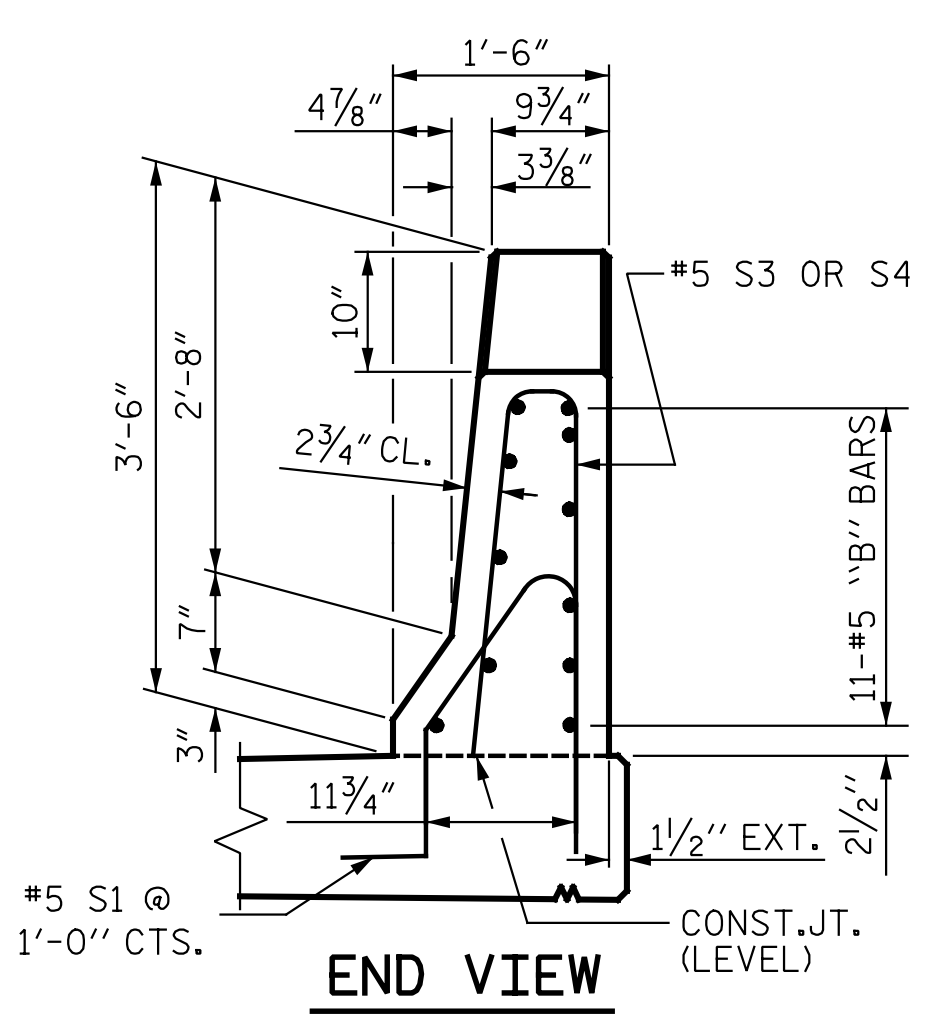

END VIEW

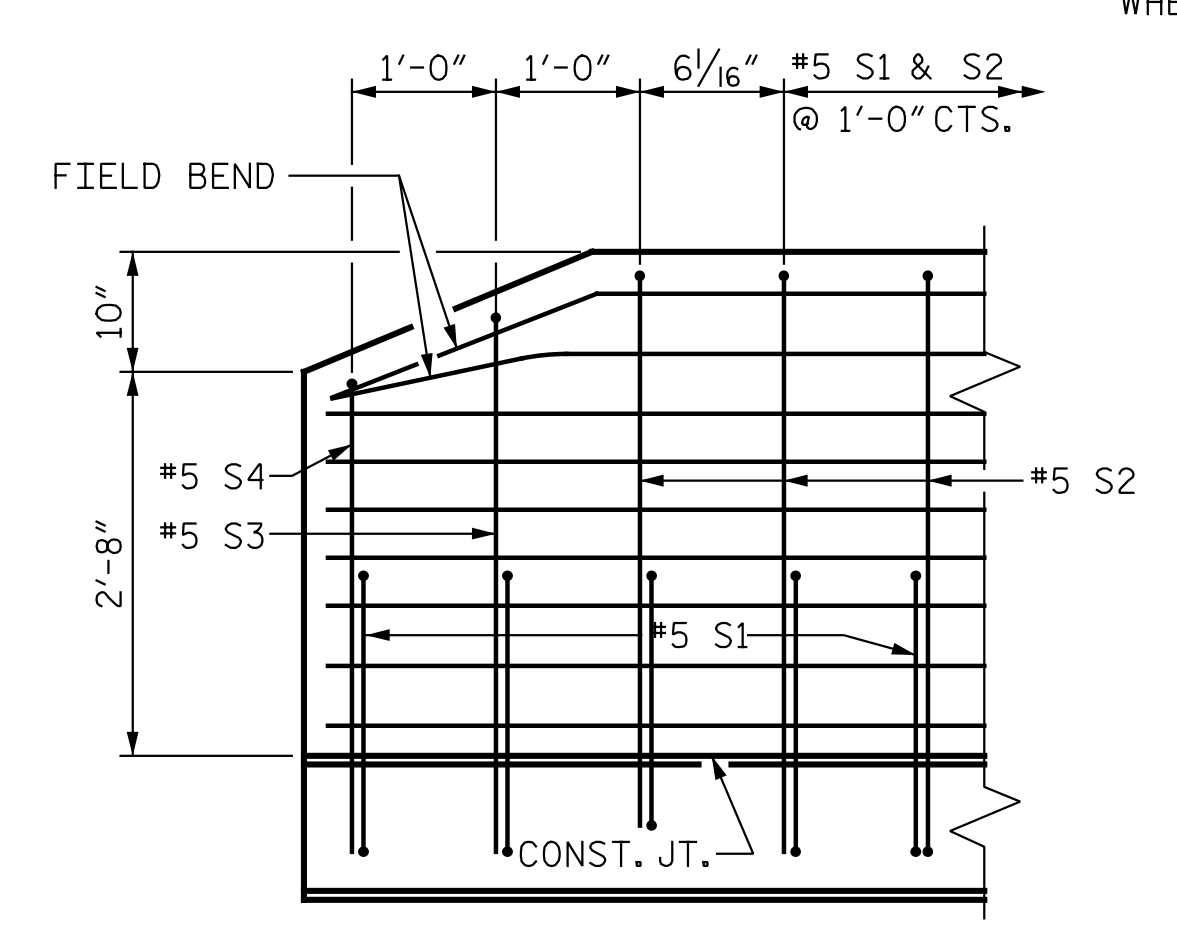

SIDE VIEW

END OF RAIL DETAILS

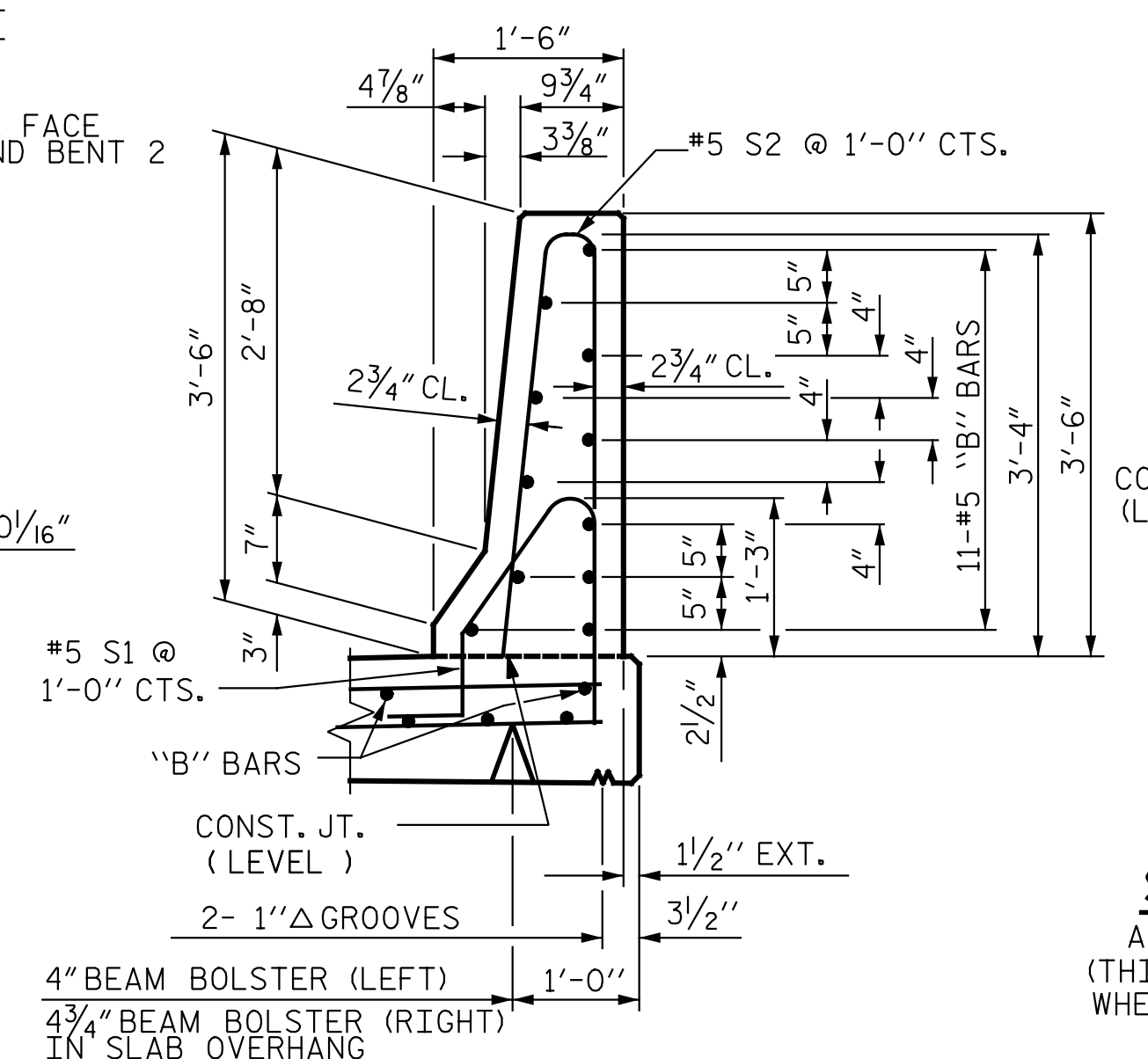

SECTION THRU RAIL

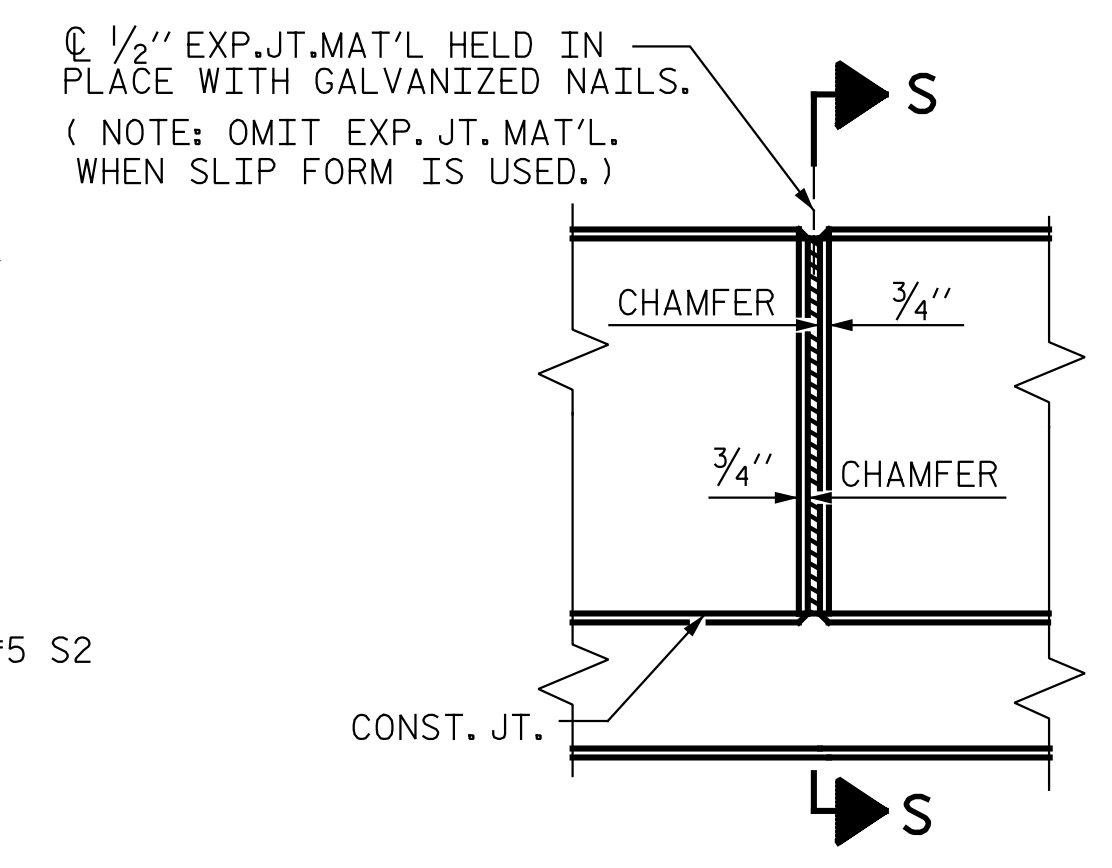

**ELEVATION AT EXPANSION JOINTS
BARRIER RAIL DETAILS**

NOTES

THE BARRIER RAIL IN EACH SPAN SHALL NOT BE CAST UNTIL ALL SLAB CONCRETE IN THAT SPAN HAS BEEN CAST AND HAS REACHED A MINIMUM COMPRESSIVE STRENGTH OF 3,000 PSI.

ALL REINFORCING STEEL IN BARRIER RAILS SHALL BE EPOXY COATED.

GROOVED CONTRACTION JOINTS, 1/2" IN DEPTH, SHALL BE TOOLED IN ALL EXPOSED FACES OF THE BARRIER RAIL AND IN ACCORDANCE WITH ARTICLE 825-10(B) OF THE STANDARD SPECIFICATIONS. THE CONTRACTION JOINT SHALL BE LOCATED AT EACH THIRD POINT BETWEEN BARRIER RAIL EXPANSION JOINTS. ONLY ONE CONTRACTION JOINT IS REQUIRED AT MIDPOINT OF BARRIER RAIL SEGMENTS LESS THAN 20 FEET IN LENGTH AND NO CONTRACTION JOINTS ARE REQUIRED FOR THOSE SEGMENTS LESS THAN 10 FEET IN LENGTH.

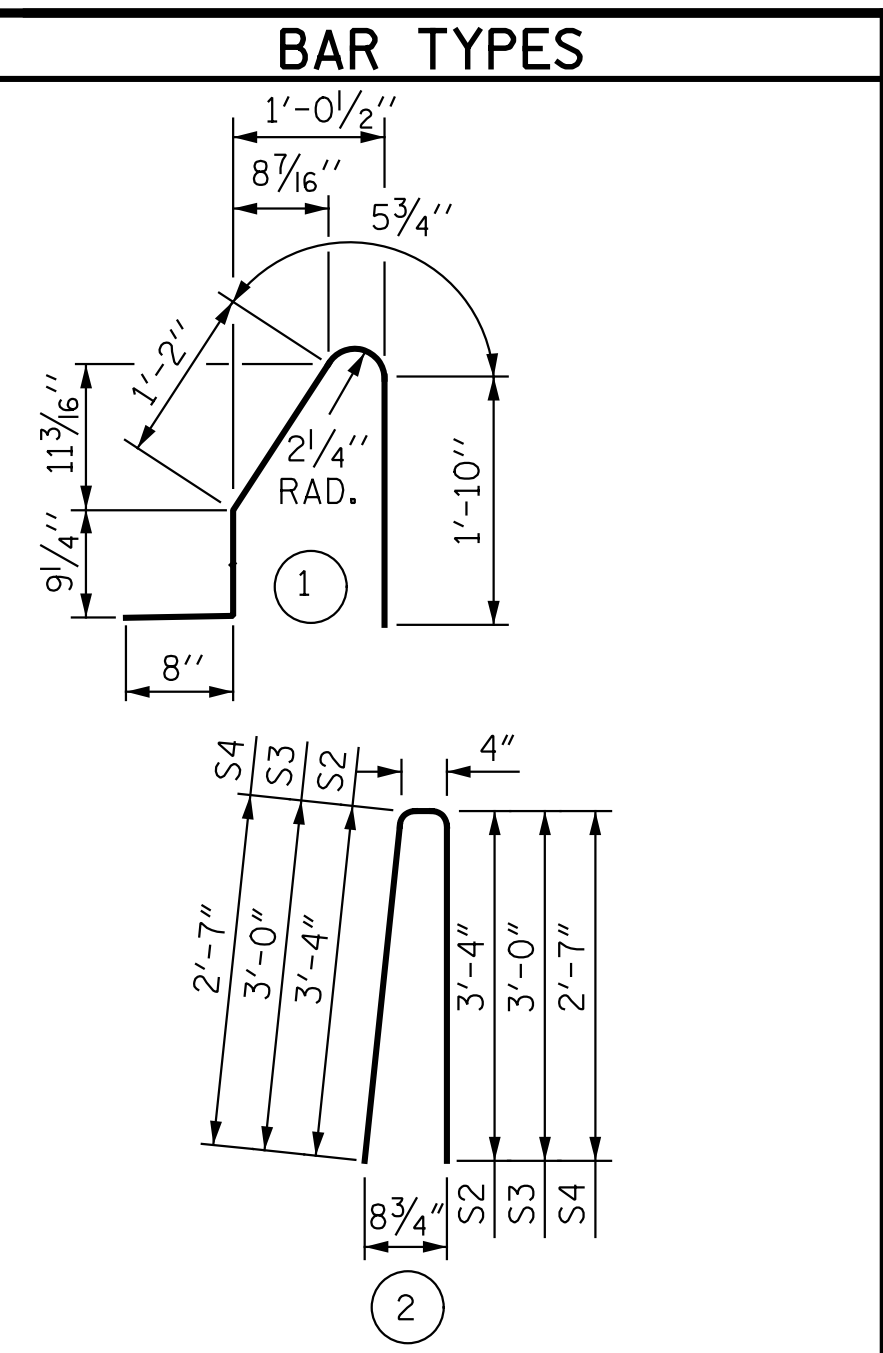

ALL BAR DIMENSIONS ARE OUT TO OUT

BILL OF MATERIAL
FOR CONCRETE BARRIER RAIL ONLY

BAR NO.	SIZE	TYPE	LENGTH	WEIGHT
*S1	240 #5	1	4'-11"	1231
*S2	232 #5	2	7'-0"	1694
*S3	4 #5	2	6'-4"	26
*S4	4 #5	2	5'-6"	23
*B1	22 #5	STR.	29'-0"	665
*B2	22 #5	STR.	29'-3"	671
*B3	44 #5	STR.	29'-8"	1361

SECTION S-S
AT DAM IN OPEN JOINT
(THIS IS TO BE USED ONLY WHEN SLIP FORM IS USED)

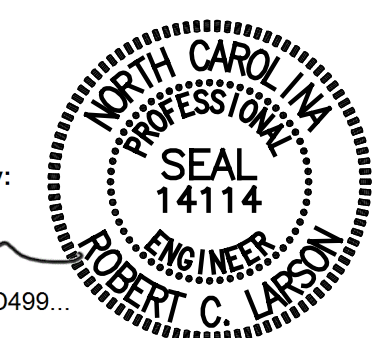

PROJECT NO. R-2514D
JONES COUNTY
STATION: 320+39.56 -L-

SHEET 1 OF 1

STATE OF NORTH CAROLINA
DEPARTMENT OF TRANSPORTATION
RALEIGH
STANDARD
CONCRETE BARRIER RAIL
STD. NO. CBR1 LEFT LANE

DESIGN ENGINEER OF RECORD:	DATE:	5/12/2015
DRAWN BY: J. WEATHERBURNE	DATE:	07/14/13
CHECKED BY: R. C. LARSON	DATE:	07/15/13
DRAWN BY: ARB 5/87	REV. 10/1/11	MAA/GM
CHECKED BY: SJD 9/87	REV. 7/12	MAA/GM
	REV. 6/13	MAA/GM

REVISIONS		SHEET NO.	
NO.	DATE	NO.	DATE
1		3	
2		4	

TOTAL SHEETS: SOI-24

KCI Associates
of North Carolina, P.A.
DWG. REF. NO. 12 OF 24