

**This electronic collection of documents is provided
for the convenience of the user
and is Not a Certified Document –**

**The documents contained herein were originally issued
and sealed by the individuals whose names and license
numbers appear on each page, on the dates appearing
with their signature on that page.**

**This file or an individual page
shall not be considered a certified document.**

ROADWAY STANDARD DRAWING

THE FOLLOWING ROADWAY STANDARDS AS APPEAR IN "ROADWAY STANDARD DRAWINGS" - PROJECT SERVICES UNIT - N.C. DEPARTMENT OF TRANSPORTATION - RALEIGH, N.C., DATED JANUARY 2012 ARE APPLICABLE TO THIS PROJECT AND BY REFERENCE HEREBY ARE CONSIDERED A PART OF THESE PLANS:

STD. NO.	TITLE
904.10	ORIENTATION OF GROUND MOUNTED SIGNS
904.50	MOUNTING OF TYPE 'D', 'E', AND 'F' SIGN ON 'U' CHANNEL POSTS

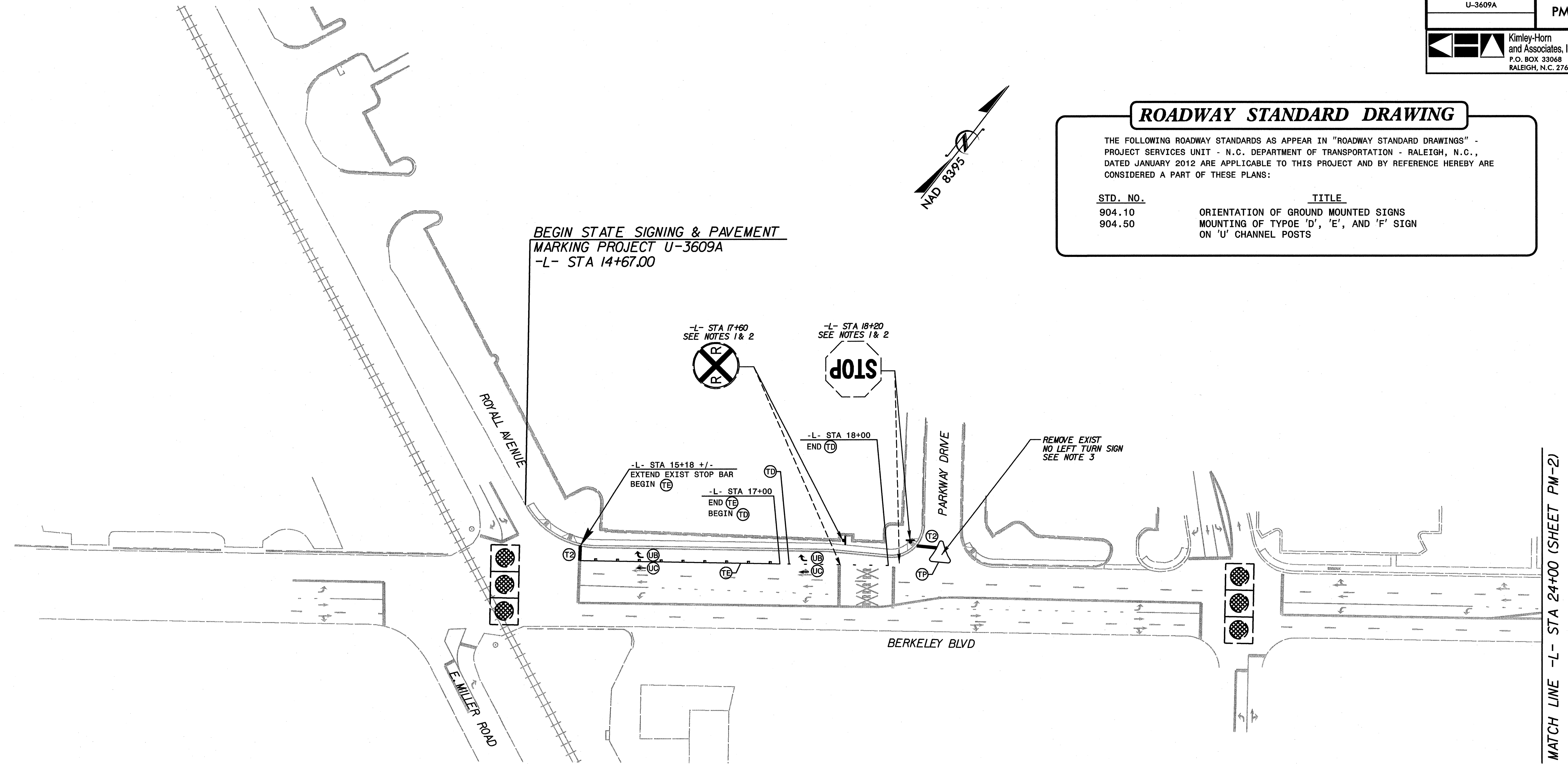



PAVEMENT MARKING LINES

- TA - THERMOPLASTIC (4" WHITE, 90 MILS) EDGE LINE
- TC - THERMOPLASTIC (4" WHITE, 120 MILS) 4" x 10' SKIP
- TD - THERMOPLASTIC (4" WHITE, 120 MILS) 3' x 9' WHITE MINISKIP
- TE - THERMOPLASTIC (4" WHITE, 120 MILS) SOLID LANE LINE
- TF - THERMOPLASTIC (4" YELLOW, 120 MILS) 10' YELLOW SKIP LINE
- TH - THERMOPLASTIC (4" YELLOW, 120 MILS) SINGLE CENTER LINE
- TI - THERMOPLASTIC (4" YELLOW, 120 MILS) DOUBLE CENTER LINE
- TK - THERMOPLASTIC (8" WHITE, 120 MILS) "WIDE" 3' x 9' WHITE MINISKIP
- TL - THERMOPLASTIC (8" WHITE, 120 MILS) "WIDE" SOLID LANE LINE
- TP - THERMOPLASTIC (8" WHITE, 90 MILS) GORELINE
- T2 - THERMOPLASTIC (24" WHITE, 120 MILS) STOP BAR

PAVEMENT MARKING SYMBOLS

- UA - THERMOPLASTIC (LEFT TURN ARROW, 90 MILS)
- UB - THERMOPLASTIC (RIGHT TURN ARROW, 90 MILS)
- UC - THERMOPLASTIC (STRAIGHT ARROW, 90 MILS)
- UD - THERMOPLASTIC (COMBINATION, STRAIGHT & LEFT TURN ARROW, 90 MILS)
- UE - THERMOPLASTIC (COMBINATION, STRAIGHT & RIGHT TURN ARROW, 90 MILS)
- UI - THERMOPLASTIC (ALPHANUMERIC CHARACTER, 120 MILS)
- US - THERMOPLASTIC ('SHARK TEETH' YIELD LINE, 90 MILS)

PAVEMENT MARKER LEGEND

-  CRYSTAL / RED PAVEMENT MARKER
-  YELLOW / YELLOW PAVEMENT MARKER
-  DIRECTION OF TRAFFIC FLOW

SIGNING AND PAVEMENT MARKING NOTES:

- A. ALL PAVEMENT MARKINGS SHALL BE THERMOPLASTIC.
- B. CONTRACTOR SHALL TIE PROPOSED MARKINGS TO EXISTING MARKINGS AT PROJECT LIMITS.
- C. CONTRACTOR SHALL MILL ANY EXISTING MARKINGS IN CONFLICT WITH PROPOSED.
- D. DO NOT PLACE PAVEMENT MARKINGS ON CROSSWALKS.
- E. RAISED REFLECTIVE PAVEMENT MARKERS ARE TO BE PLACED ACCORDING TO NCDOT ROADWAY STANDARD DRAWINGS.
- F. REMOVE AND RESET EXISTING STREET SIGNS.

PAY ITEM NOTES:

1. DISPOSAL OF SUPPORT, U-CHANNEL
2. SIGN ERECTION, RELOCATE TYPE "E" (GROUND MOUNTED)
3. DISPOSAL OF SIGN SYSTEM, U-CHANNEL.

SUMMARY OF QUANTITIES

ITEM NO.		ITEM DESCRIPTION	QUANTITY	UNIT
DESC. NO.	SECT. NO.			
4072000000	903	SUPPORTS, 3-LB STEEL U-CHANNEL	220	LF
4116100000	904	SIGN ERECTION, RELOCATE TYPE E (GROUND MOUNTED)	17	EA
4155000000	907	DISPOSAL OF SIGN SYSTEM, U-CHANNEL	1	EA
4192000000	907	DISPOSAL OF SUPPORT, U-CHANNEL	14	EA

SHEET 1 OF 4

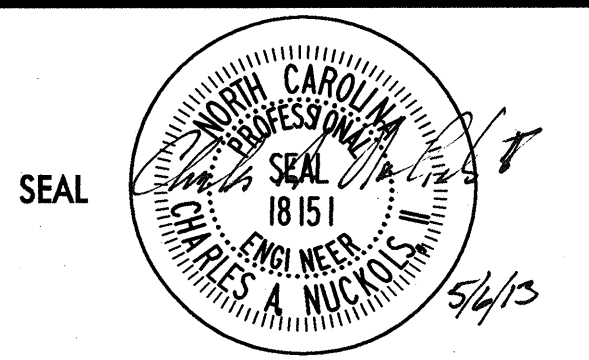
APPROVED:	DATE:	<h4>PAVEMENT MARKING AND SIGNING PLAN</h4>
		
SCALE: 1" = 50'	REVISIONS	
DATE: 06-11-12		
DWG. BY: DAS		
DESIGN BY: JJP		
REVIEWED BY: CAN	CADD FILE:	

K:\RAL_Roadway\01746003 (Berkeley Blvd)\Plan\TCP\01746003_PM.dgn 5/1/2013

MATCH LINE -L- STA 24+00 (SHEET PM-1)

MATCH LINE -L- STA 38+00 (SHEET PM-3)

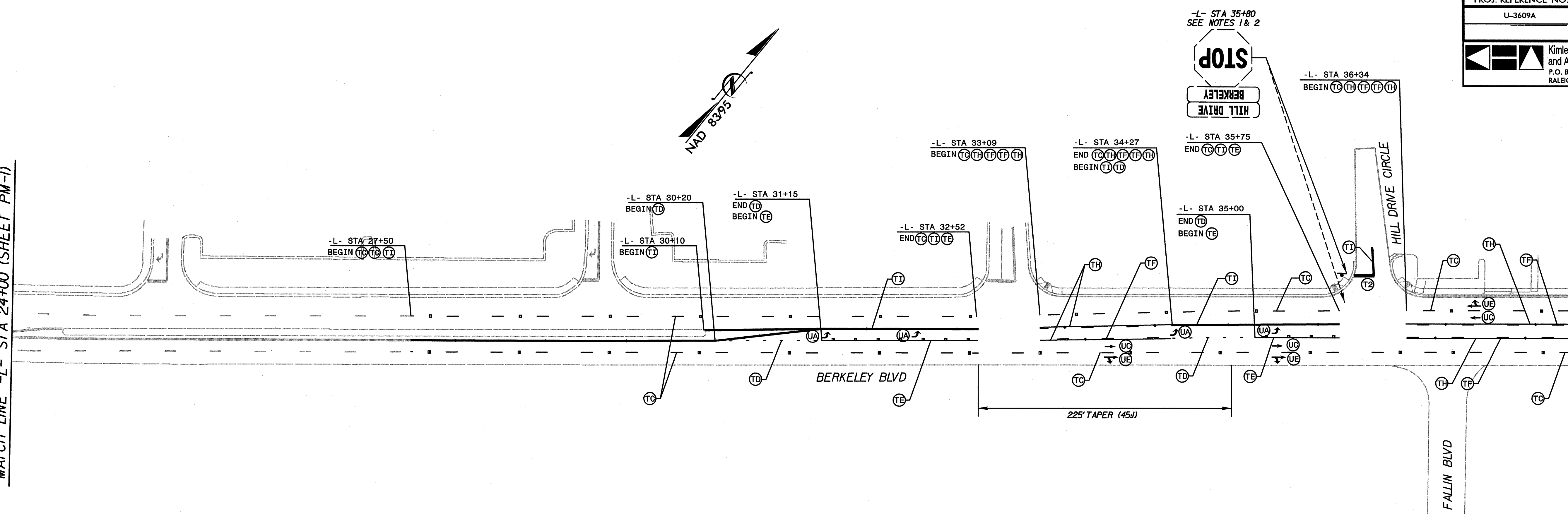

SHEET 2 OF 4

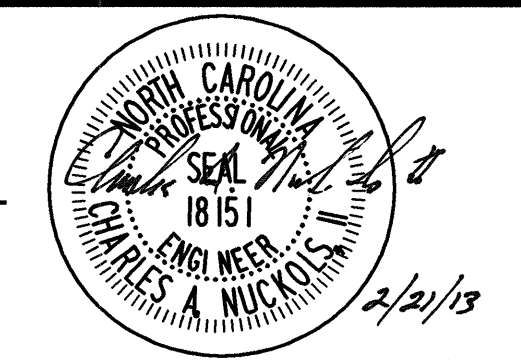
APPROVED: _____	DATE: _____
	
SEAL CHARLES A. NUCKOLS 2/21/13	
PAVEMENT MARKING AND SIGNING PLAN	
SCALE: 1" = 50'	REVISIONS
DATE: 06-01-11	
DWG. BY: DAS	
DESIGN BY: JJP	
REVIEWED BY: CAN	

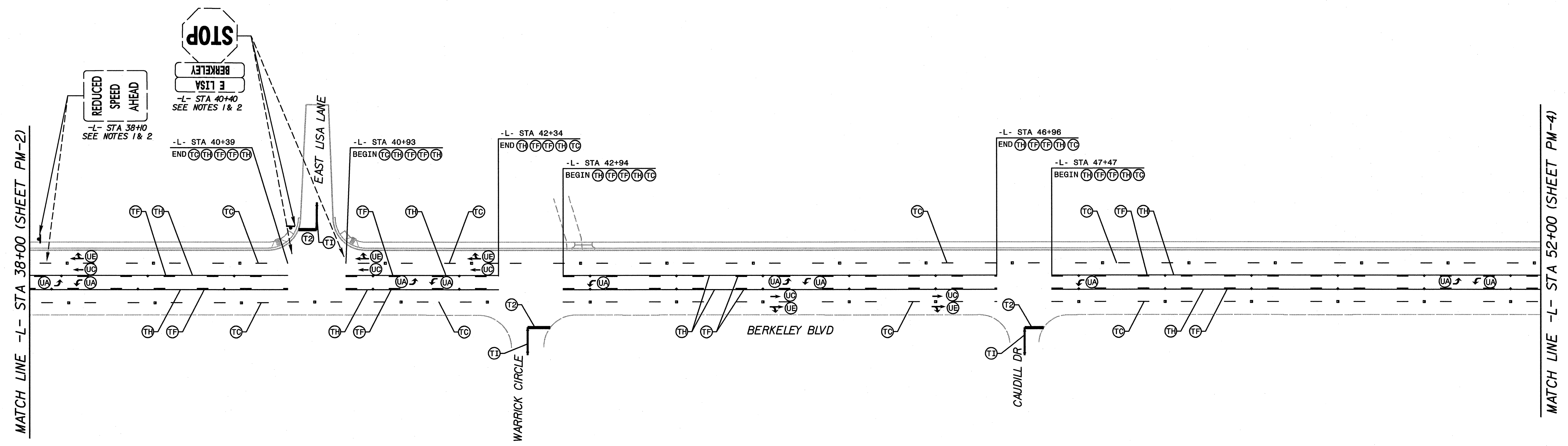
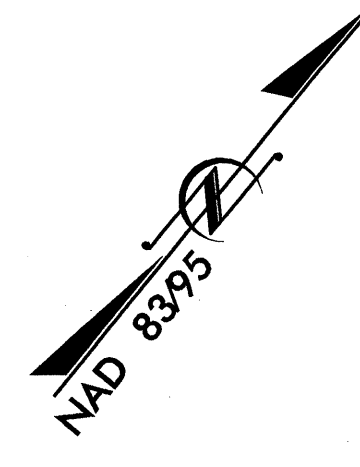

K:\RAL_Roadway\011746003 (Berkeley Blvd)\Plan\TCP\011746003_PM_3.dgn

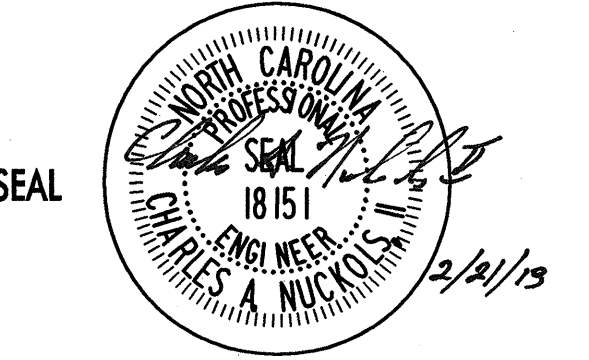
APPROVED: _____	DATE: _____	PAVEMENT MARKING AND SIGNING PLAN
		
SCALE: 1" = 50'	DATE: 06-11-12	REVISIONS
DWG. BY: DAS	DESIGN BY: JJP	
REVIEWED BY: CAN	CADD FILE:	

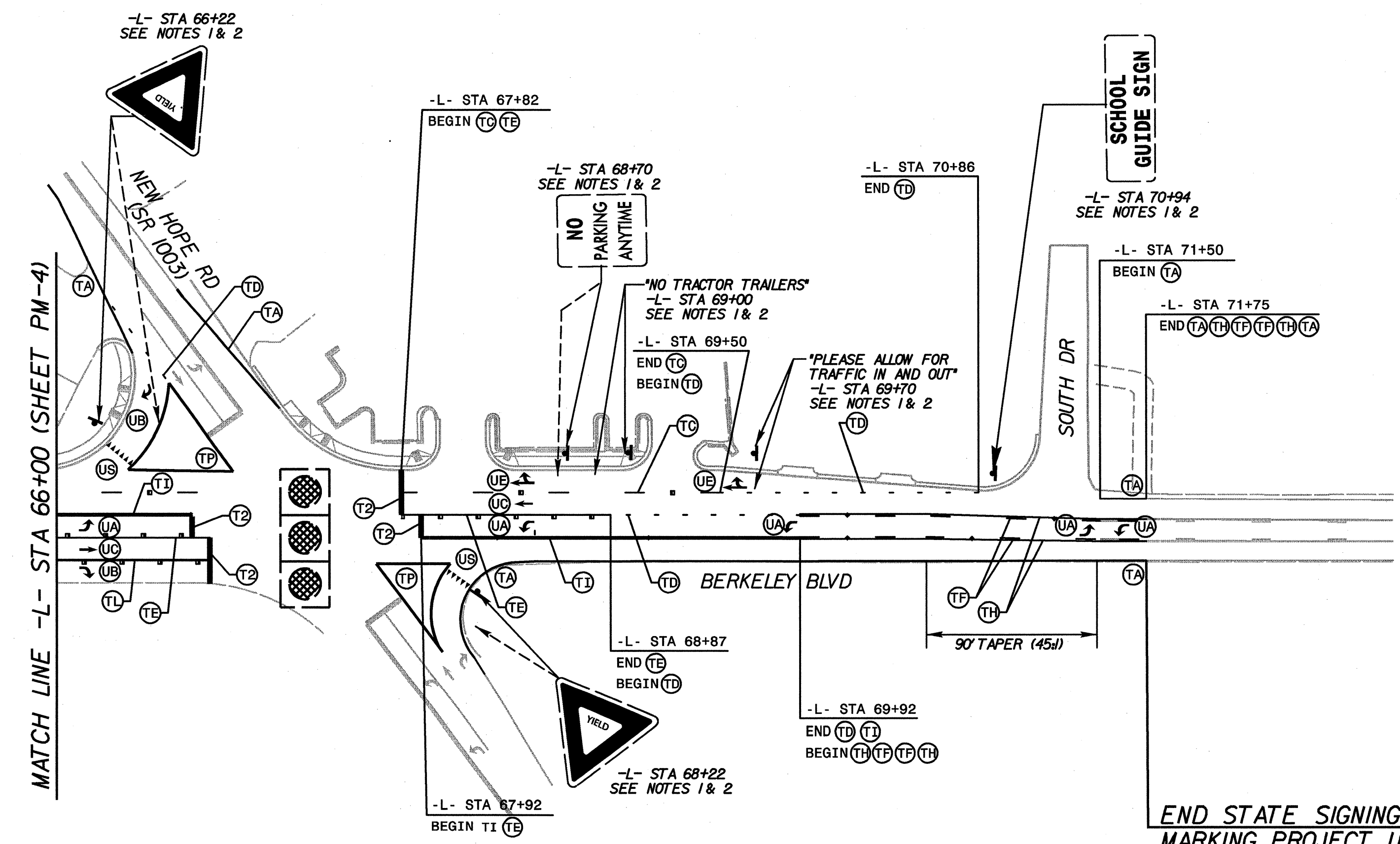
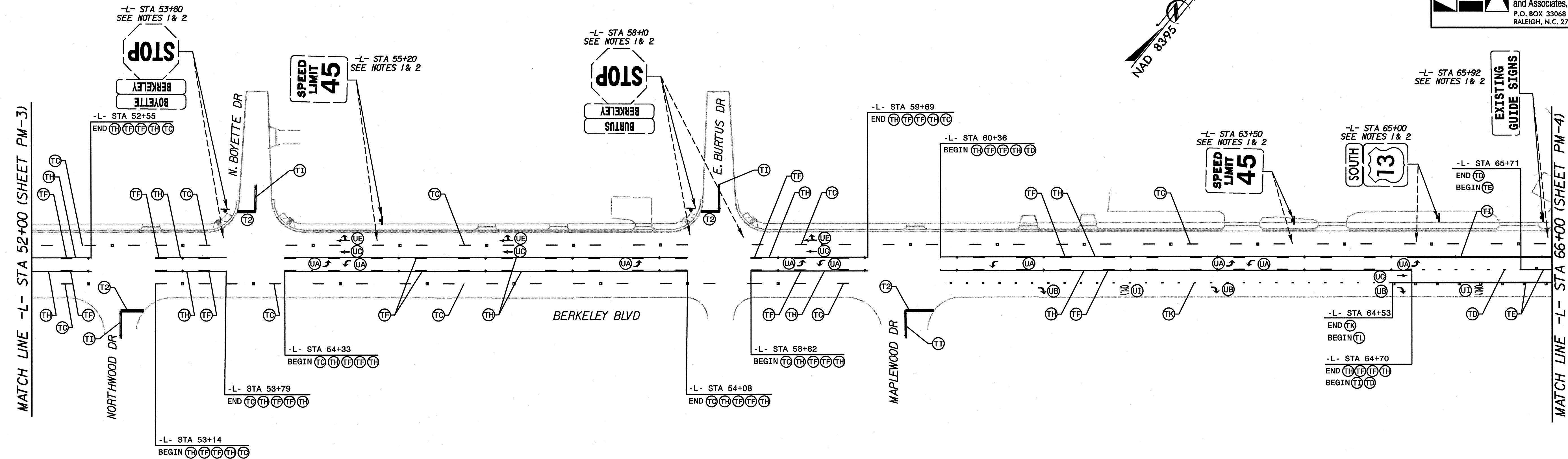

END STATE SIGNING & PAVEMENT
MARKING PROJECT U-3609A
-L- STA 71+75.00

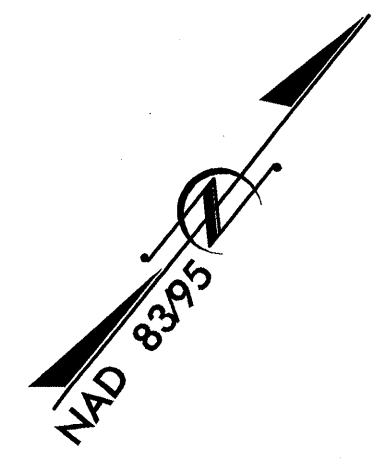

K:\PAL_Roadway\01746003 (Berkeley Blvd)\Plan\TFC\01746003_PM_4.dgn
2/21/2013

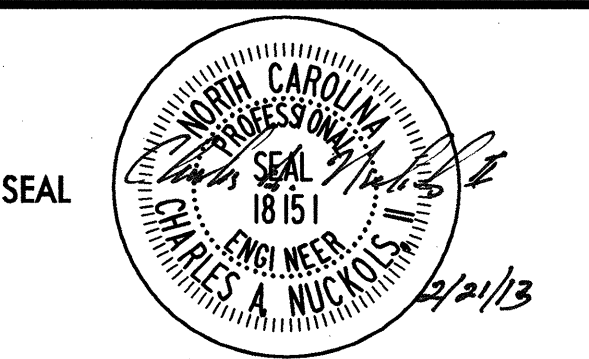
APPROVED: _____	DATE: _____	PAVEMENT MARKING AND SIGNING PLAN
		
SCALE: 1" = 50'	REVISIONS	
DATE: 06-11-12		
DWG. BY: DAS		
DESIGN BY: JJP		
REVIEWED BY: CAN		