

Construction Details - Strain Poles

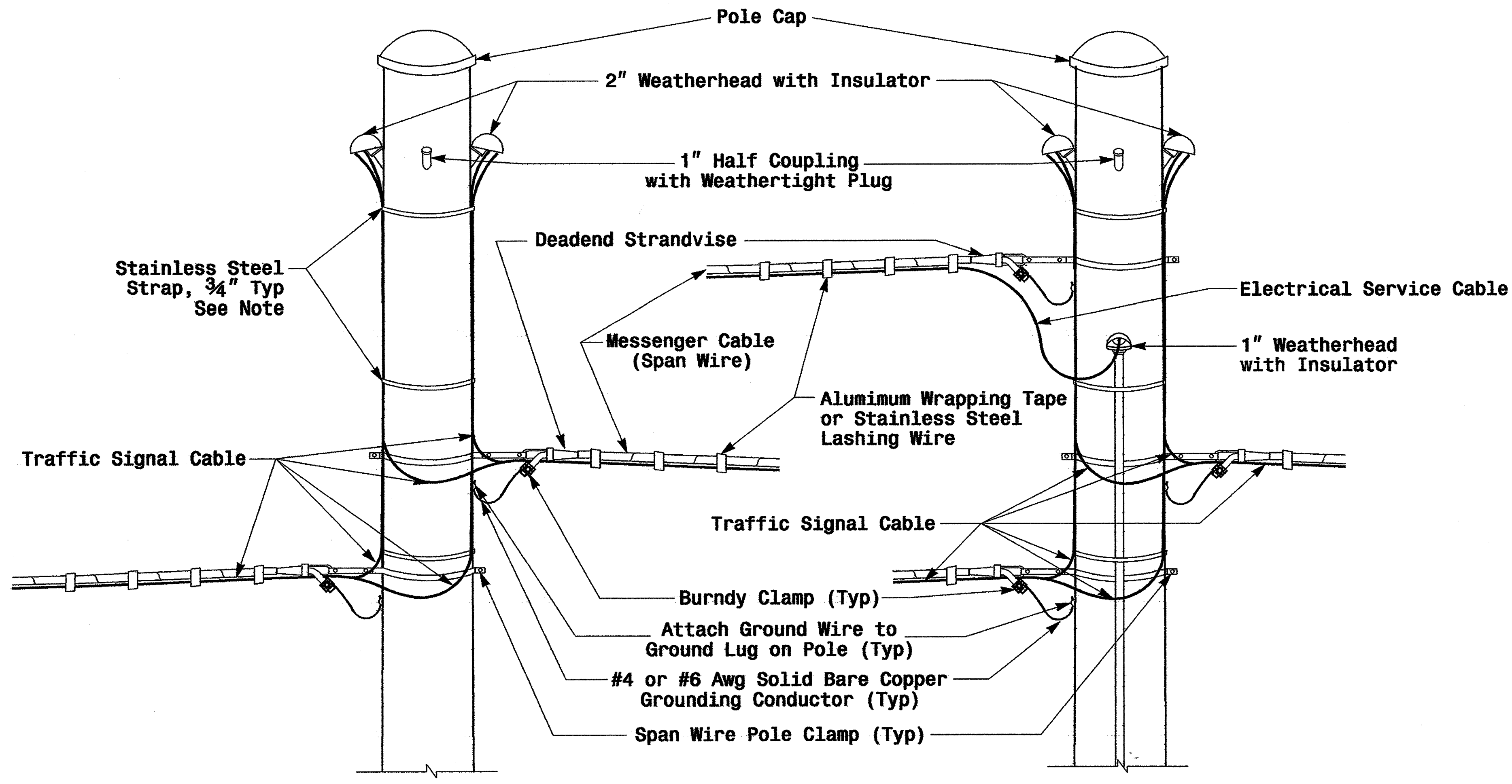

Note: Strap all signal cables to the side of the pole with 3/4" stainless steel straps when the distance between the spanwire attachment clamp and the weatherheads exceeds 36"

Strain Pole Attachments

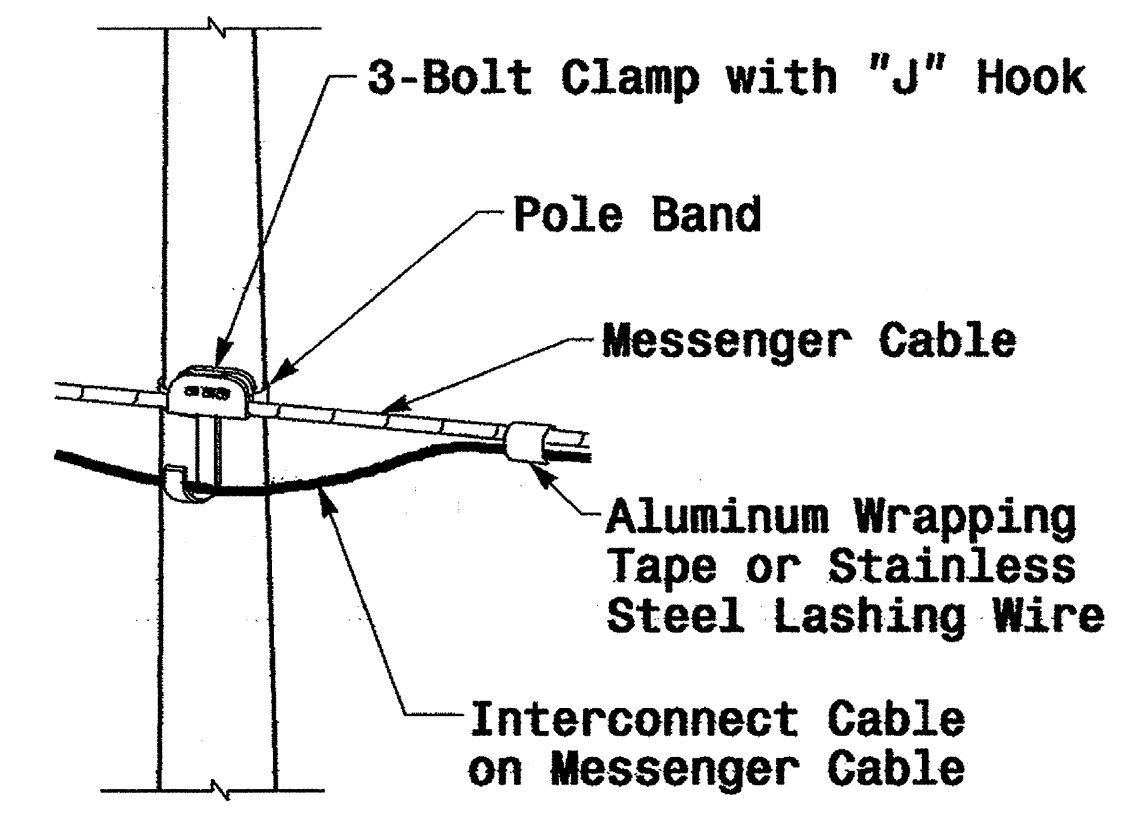

Attachment of Cable to Intermediate Metal Pole

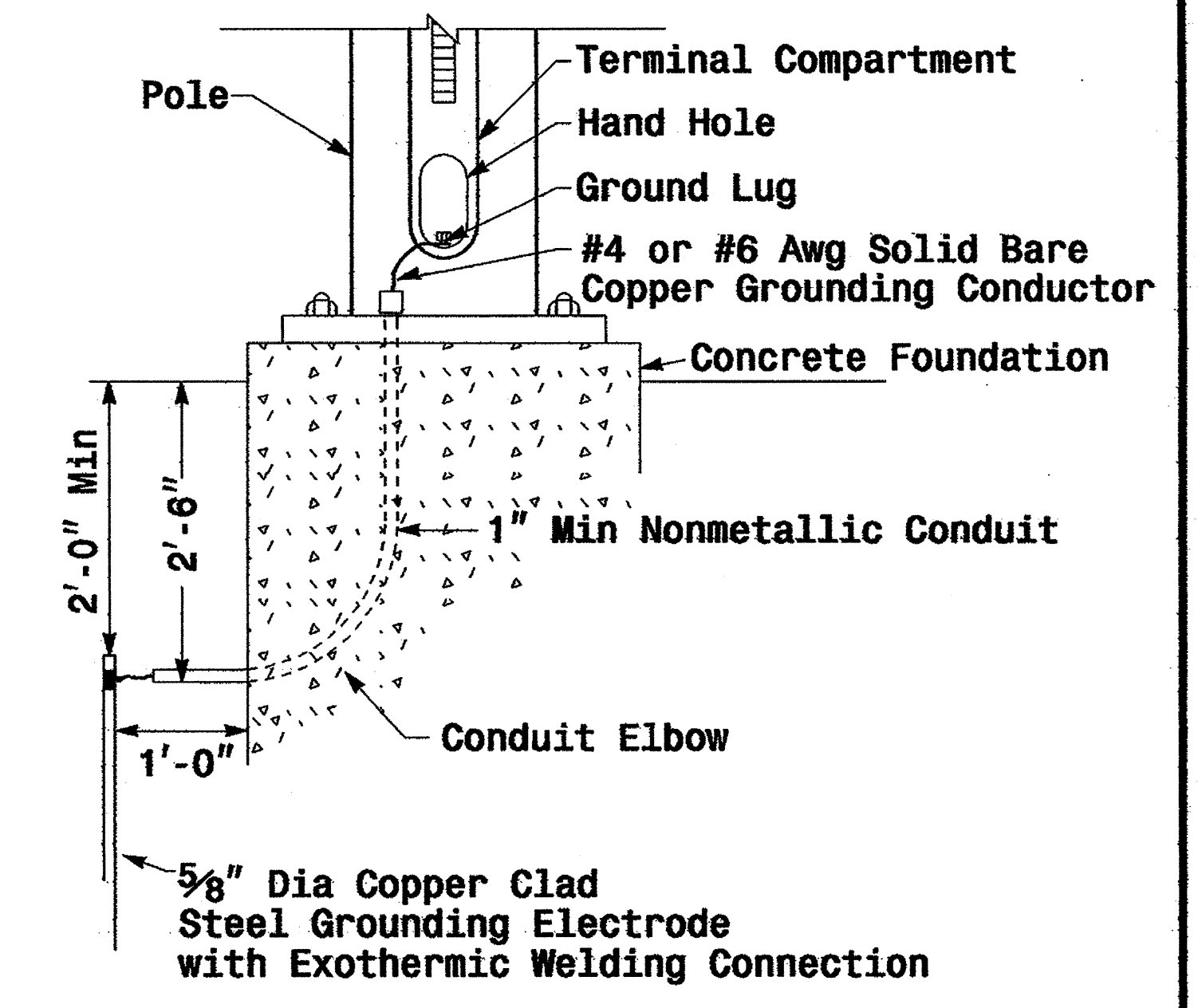

Metal Pole Grounding Detail

01-SEP-2005 16:33
w:\p\p\res-un\11\work\groups\2004 metal pole standard\ds\2004 m6.dgn
palexander

	Construction Details Strain Poles		
	PLAN DATE: May 2005 PREPARED BY: C.F. ANDREWS	REVIEWED BY: P.L. ALEXANDER REVIEWED BY: D.C. SARKAR	
SCALE: 0 NA NONE		SIGNATURE: <i>P.L. Alexander</i> DATE: 9-1-05 SIG. INVENTORY NO.	