

Section A-A
(See drawing M 2)
Pole Base Plate

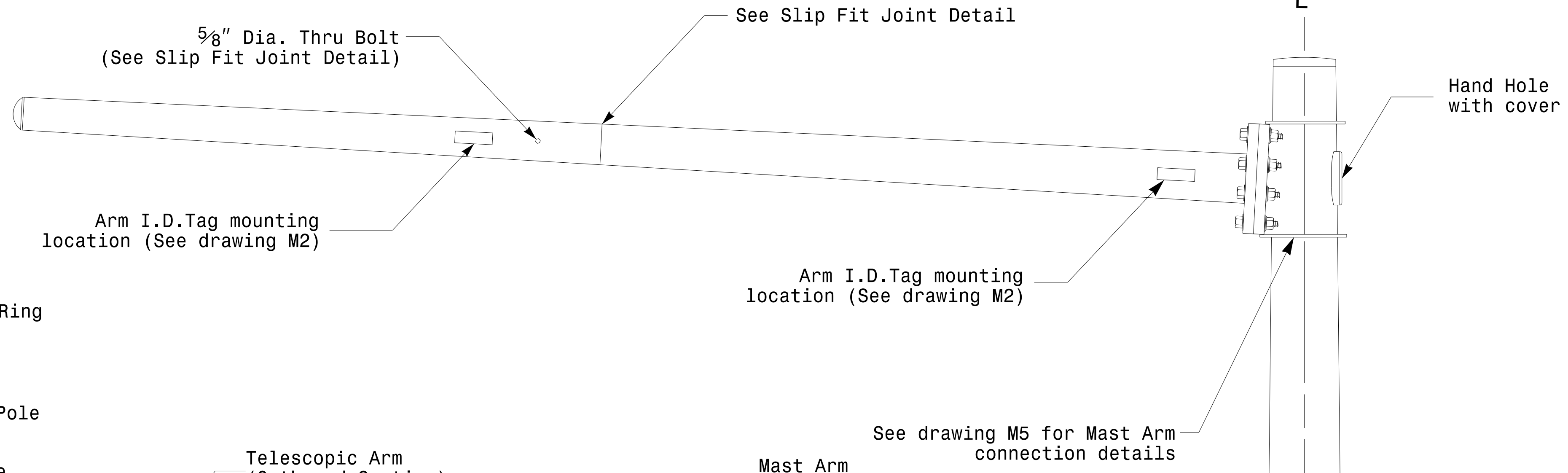

3/4" Factory Drilled Hole in Outboard Tube.
Field Drill Inboard Tube.
5/8" Galvanized Thru Stud with
(2) Hex. Locknuts Each.

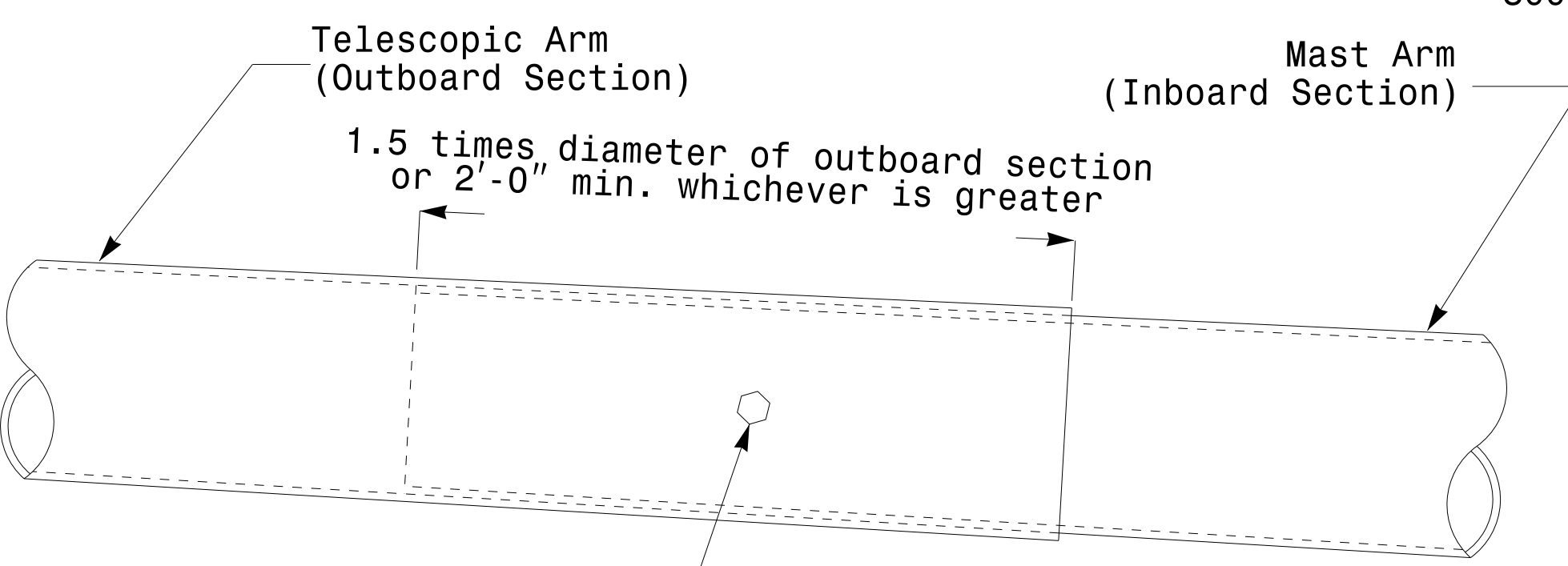

Slip Fit Joint Detail for Mast Arm

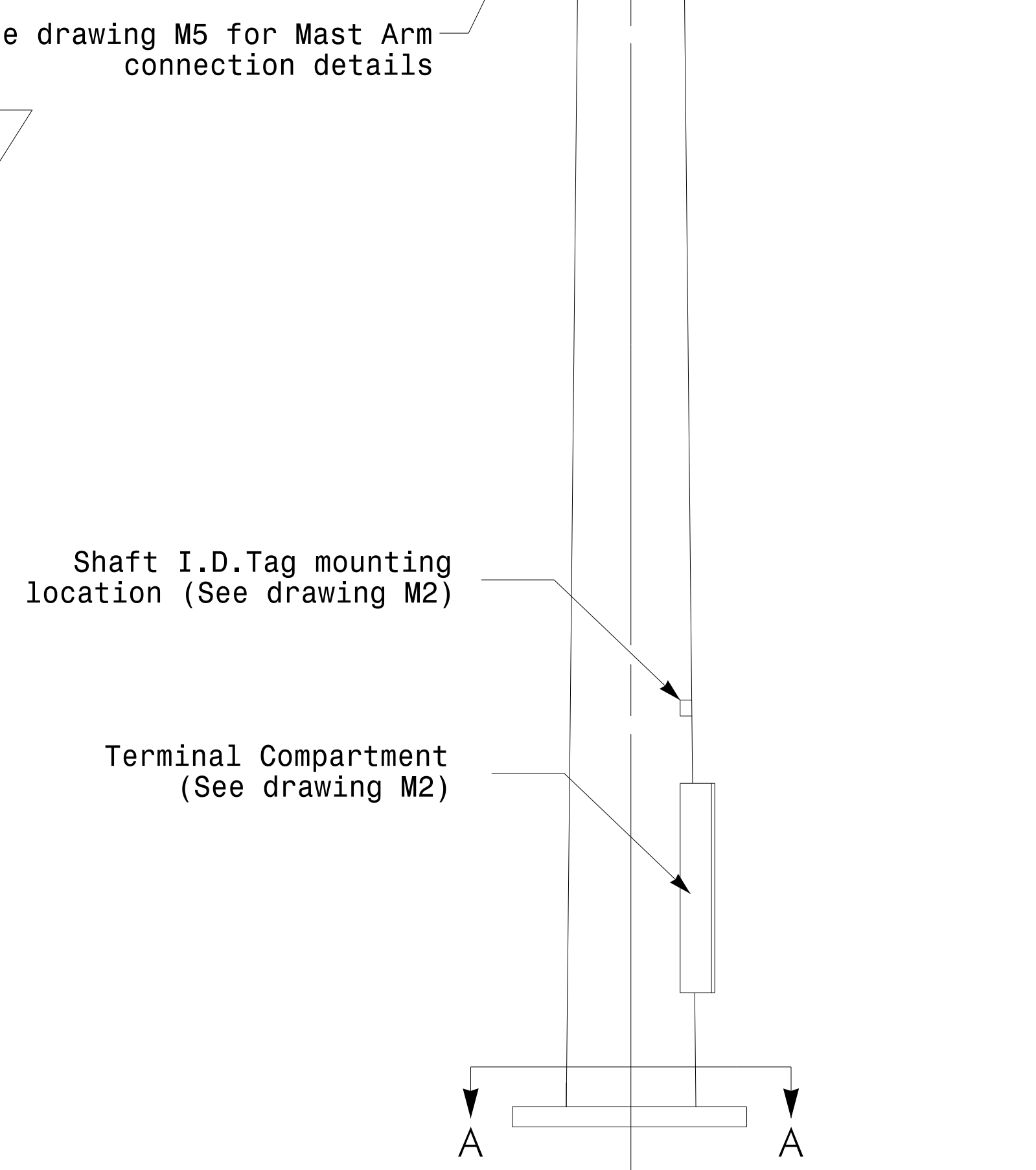

Monotube Mast Arm Pole
(.14in./ft. taper)

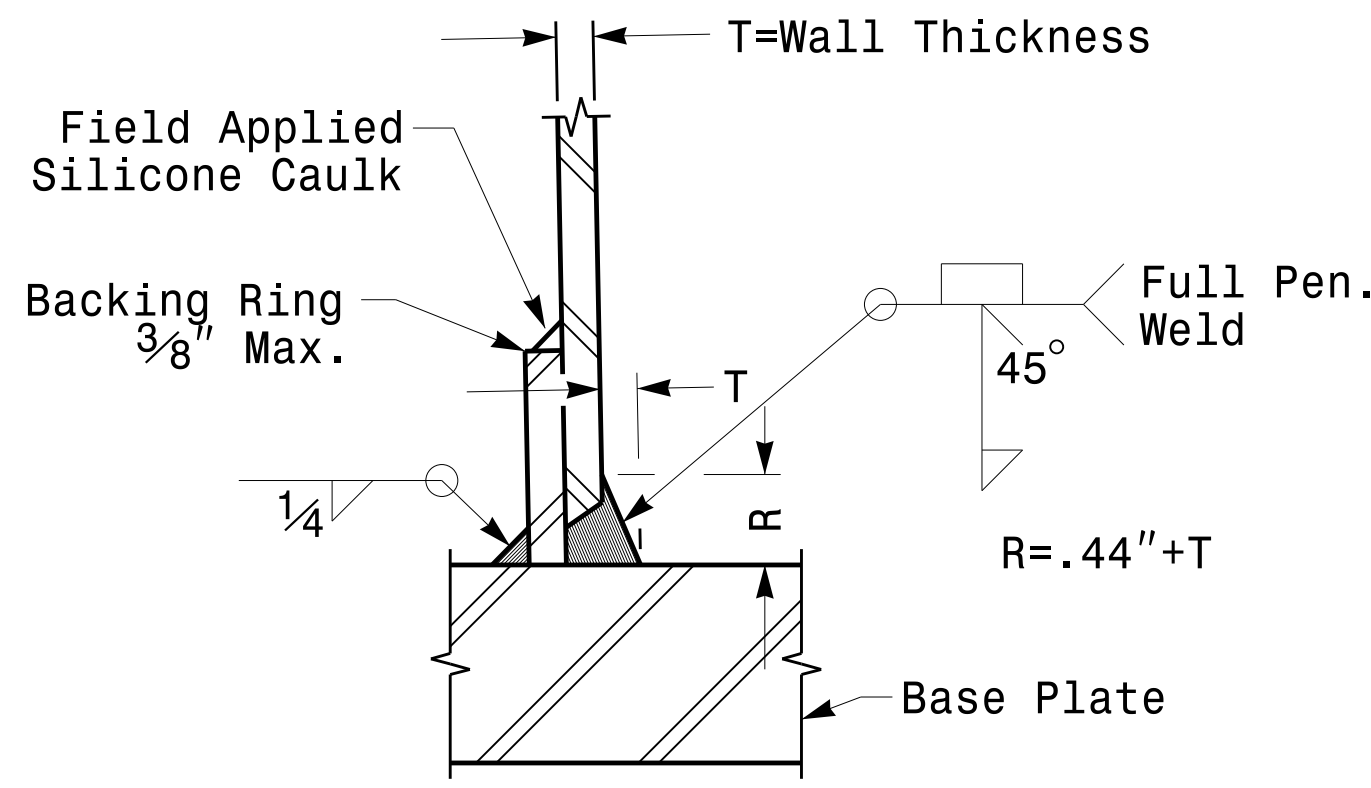

Section B-B
(Pole Attachment to Base Plate)
Full-Penetration Groove Weld Detail

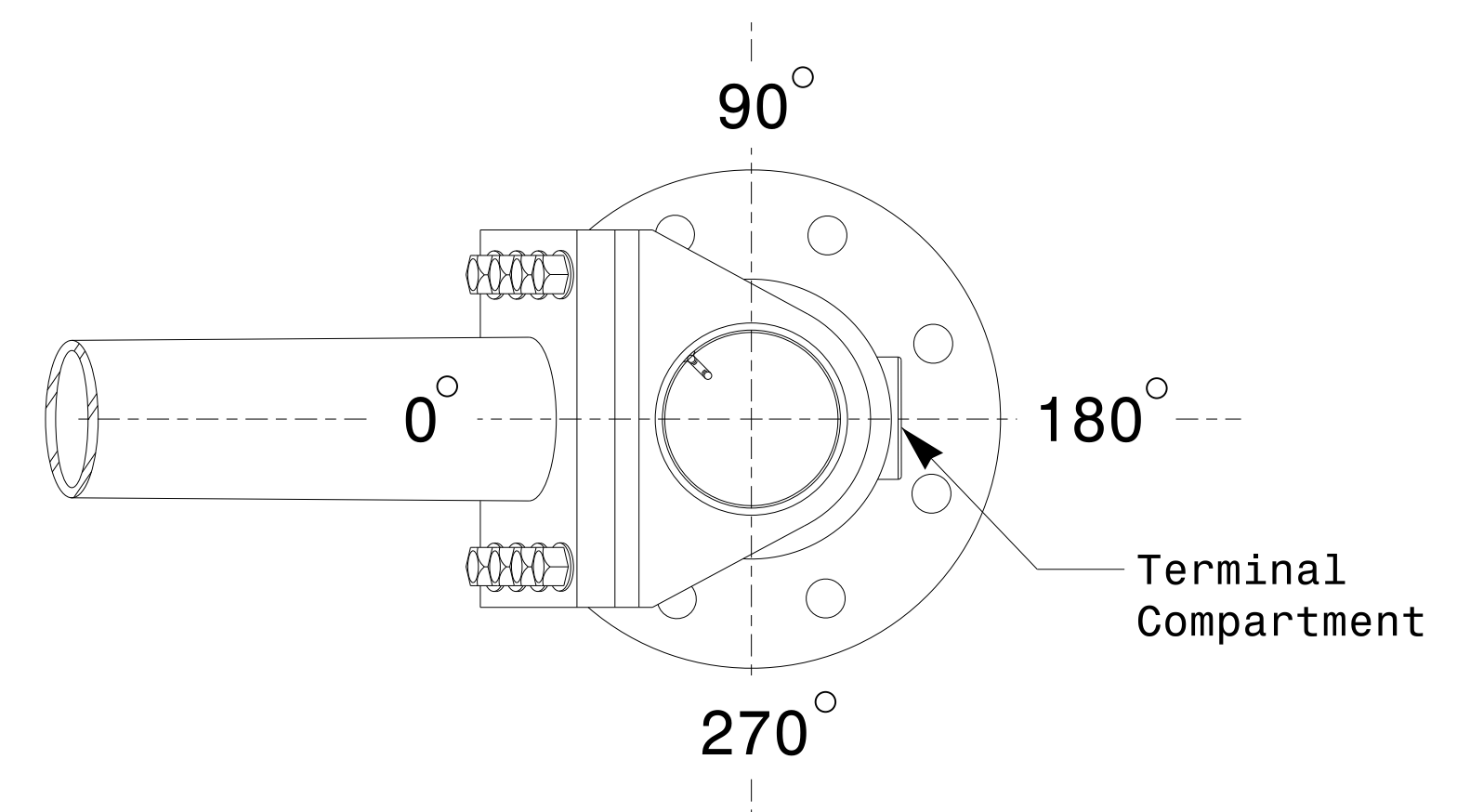

Mast Arm Radial Orientation

	Typical Fabrication Details for Mast Arm Poles		
	PLAN DATE: AUGUST 2013 PREPARED BY: N. BITTING	DESIGNED BY: C.F. ANDREWS REVIEWED BY: D.C. SARKAR	
SCALE: 0 NA NONE	REVISIONS:	INIT. DATE:	SIG. INVENTORY NO.:

26-AUG-2014 08:50
 S:\IT\2013\15\SIGNAL\Signal Design\Section\Eastern Region\M4_Fab_Details\MastArms.dgn
 T:\jll\cwy

Fabrication Details – Mast Arm Poles