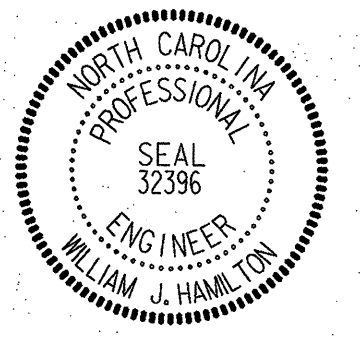

CONTRACT: C203412 **T.I.P.: R-2612B**

STATE OF NORTH CAROLINA
DEPARTMENT OF TRANSPORTATION

SIGNING PLAN
GUILFORD COUNTY

LOCATION: US 421 AT SR 3418 (NEELEY ROAD)
SOUTH OF GREENSBORO

TIP NO. R-2612B	SHEET NO. SIGN-1
APPROVED: <i>[Signature]</i>	
DATE: 3/19/14	
SEAL	
	

ROADWAY STANDARD DRAWING

THE FOLLOWING ROADWAY STANDARDS AS APPEAR IN "ROADWAY STANDARD DRAWINGS" - PROJECT SERVICES UNIT - N.C. DEPARTMENT OF TRANSPORTATION - RALEIGH, N.C., DATED JANUARY 2012 ARE APPLICABLE TO THIS PROJECT AND BY REFERENCE HEREBY ARE CONSIDERED A PART OF THESE PLANS:

STD. NO.	TITLE
901.10	TYPE 'A' SIGNS
901.50	ARROWS AND SHIELDS
901.60	RIVET SPACING FOR OVERLAYED SIGNS
901.70	SIGN STRINGERS AND SUPPORT SPACING
901.80	SIGN MOUNTING DETAILS - FOR TYPE A AND TYPE B SIGNS
903.10	GROUND MOUNTED SIGN SUPPORTS (SHEETS 1 AND 3)
904.10	ORIENTATION OF GROUND MOUNTED SIGNS
904.20	SECONDARY SIGN MOUNTING
904.40	MILEPOST AND PLACEMENT
904.50	MOUNTING OF TYPE 'D', 'E' AND 'F' SIGNS ON 'U' CHANNEL POSTS
1264.02	OBJECT MARKERS - INSTALLATION

GENERAL NOTES

- . SIGNS FURNISHED BY STATE
- . ALL TYPE 'D' SIGNS SHALL BE MOUNTED ON TWO U-CHANNEL POSTS UNLESS OTHERWISE INDICATED ON THE PLANS.
- . IF REMOVAL OR RELOCATION OF SIGNS ON PRIVATE STREET (NON-STATE MAINTAINED) IS REQUIRED DUE TO CONSTRUCTION, THE CONTRACTOR SHALL INFORM THE ENGINEER. THE WORK WILL BE COMPLETED BY OTHERS.
- . WHEN NOT STATIONED OR DIMENSIONED ON PLANS, ALL 'E' AND 'F' SIGNS SHALL BE FIELD LOCATED BY THE ENGINEER
- . ALL EXISTING SIGNS ON "U" CHANNEL POST WITHIN THE PROJECT LIMITS SHALL BE REMOVED AND DISPOSED OF UNLESS OTHERWISE NOTED ON PLANS.
- . THE BACKGROUND FOR TYPE E & F SIGNS SHALL BE TYPE C REFLECTIVE SHEETING.
- . DO NOT BEGIN FABRICATION FOR TYPES A & B SIGNS MOUNTED ON OVERHEAD STRUCTURES OR STEEL SUPPORTS UNTIL "S" DIMENSIONS HAVE BEEN FIELD VERIFIED.
- . SEE ROADWAY PLANS FOR GUARD/GUIDE RAIL DETAILS.
- . INSTALL NEW CHEVRONS ON ALL LOOP RAMPS. SPACE SIGNS AT 40' SPACING ANGLED TO MAXIMIZE VISIBILITY BY APPROACHING VEHICLES. SPACING NOT SHOWN TO SCALE.
- . LOCATE MILEMARKERS THAT ARE INSTALLED BEYOND ROADWAY CONSTRUCTION LIMIT BY MEASURING FROM STATIONED MILEMARKERS ON PROJECT.

SUMMARY OF QUANTITIES

ITEM NO.		ITEM DESCRIPTION	QUANTITY	UNIT
DESC. NO.	SECT. NO.			
4048000000	902	REINFORCED CONCRETE SIGN FOUNDATION	5	C.Y.
4054000000	902	PLAIN CONCRETE SIGN FOUNDATION	2	C.Y.
4057000000	SP	OVERHEAD FOOTING	22	C.Y.
4060000000	903	SUPPORTS, BREAKAWAY STEEL BEAM	5308	LB.
4072000000	903	SUPPORTS, 3 LB STEEL U-CHANNEL	2071	L.F.
4082100000	SP	SUPPORTS, OVERHEAD SIGN STRUCTURE AT STATION "73+50 -L1-"	1	L.S.
4096000000	904	SIGN ERECTION, TYPE D	7	EA.
4102000000	904	SIGN ERECTION, TYPE E	44	EA.
4108000000	904	SIGN ERECTION, TYPE F	8	EA.
4110000000	904	SIGN ERECTION, TYPE A (GROUND MOUNTED)	12	EA.
4110000000	904	SIGN ERECTION, TYPE B (GROUND MOUNTED)	11	EA.
4114000000	907	SIGN ERECTION, MILEMARKERS	28	EA.
4116000000	907	SIGN ERECTION, OVERLAY (GROUND-MOUNTED)	2	EA.
4152000000	907	DISPOSAL OF SIGN SYSTEM, STEEL BEAM	5	EA.
4158000000	907	DISPOSAL OF SIGN SYSTEM, U-CHANNEL	65	EA.
4236000000	907	DISPOSAL OF SIGN, A, B OR C (GROUND-MOUNTED)	4	EA.

INDEX

SHEET NO.	DESCRIPTION
SIGN-1	TITLE SHEET
SIGN-2	REVISED GROUND MOUNTED SIGN SUPPORTS SHEET 2 OF 3
SIGN-3	SUPPORT CHART
SIGN-4	STRUCTURE LINE DRAWING
SIGN-5-10	SIGN DETAILS
SIGN-11	TYPE E AND F SIGNS
SIGN-12	MILEMARKER SIGNS
SIGN-13-15	EXISTING SIGNING DETAIL
SIGN-16-21	PROPOSED SIGNING DETAIL

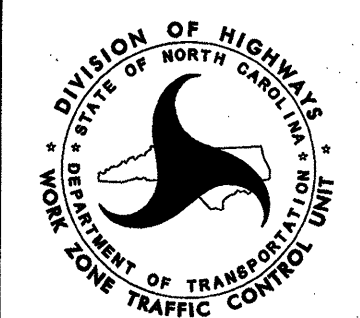
PLAN REVIEWED BY: N.C.D.O.T. SIGNING AND DELINEATION UNIT		
<u>SUSAN KUNZ</u>	SIGNING & DELINEATION REGIONAL ENGINEER	
<u>SAM COLEMAN</u>	SIGNING & DELINEATION PROJECT DESIGN ENGINEER	

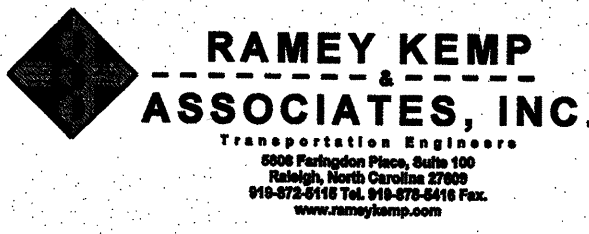
PLAN PREPARED BY: Ramey Kemp & Associates		
<u>W.JASON HAMILTON</u>	PROJECT MANAGER	
<u>NICHOLAS E. BURNS</u>	PROJECT ENGINEER	

TIP NO.	SHEET NO.
R-2612B	SIGN-2
APPROVED:	<i>RWF</i>
DATE:	3/8/12
SEAL	

STATE OF NORTH CAROLINA
 DEPT. OF TRANSPORTATION
 DIVISION OF HIGHWAYS
 RALEIGH, N.C.

ENGLISH DETAIL DRAWING FOR
GROUND MOUNTED SIGN SUPPORTS

SHEET 2 OF 3
903D10

BEAM SHAPE	BOLT SIZE	SLIP BASE PLATE DATA								KEEPER PLATE DATA								HINGE CONNECTION DATA								BREAK AWAY SUPPORT WEIGHT CONSTANT LBS.
		A ₁	B ₁	C ₁	D ₁	E ₁	T ₁	R ₁	A ₂	B ₂	C ₂	D ₂	E ₂	R ₂	T ₂	BOLT SIZE	F	G	H	I	J	K	L	R ₃	T ₃	
S3X5.7	1/2"DIA. X 3"	7"	4"	1"	3/4"	2 1/2"	1"	9/32"	7"	4"	1"	3/4"	2 1/2"	9/32"	28 GAUGE	1/2"DIA. X 1 1/4"	2 1/4"	3 1/2"	4"	1/2"	1"	1 1/2"	2"	9/32"	3/8"	18
S4X7.7	1/2"DIA. X 3"	8"	4"	1"	3/4"	2 1/2"	1"	9/32"	8"	4"	1"	3/4"	2 1/2"	9/32"	28 GAUGE	1/2"DIA. X 1 1/4"	2 5/8"	3 1/2"	4"	1/2"	1"	1 1/2"	2"	9/32"	3/8"	20
W6X9	1/2"DIA. X 3"	10"	5"	1"	3/4"	3 1/2"	1"	9/32"	10"	5"	1"	3/4"	3 1/2"	9/32"	28 GAUGE	1/2"DIA. X 1 1/4"	4"	3 1/2"	4"	3/4"	1"	1 1/2"	2"	9/32"	3/8"	32
W6X12	5/8"DIA. X 3 3/4"	11"	5"	1 1/4"	7/8"	3 1/4"	1 1/4"	1 1/32"	11"	5"	1 1/4"	7/8"	3 1/4"	1 1/32"	28 GAUGE	5/8"DIA. X 2 1/4"	4"	4"	4 1/2"	3/4"	1 1/8"	5/8"	2 1/4"	1 1/32"	3/8"	39
W6X16	5/8"DIA. X 3 3/4"	12"	6"	1 1/4"	7/8"	4 1/4"	1 1/2"	1 1/32"	12"	6"	1 1/4"	7/8"	4 1/4"	1 1/32"	28 GAUGE	5/8"DIA. X 2 1/2"	4"	4"	4 1/2"	3/4"	1 1/8"	5/8"	2 1/4"	1 1/32"	3/8"	47
W8X18	5/8"DIA. X 4 1/4"	13 1/2"	6 1/2"	1 1/4"	7/8"	4 3/4"	1 1/2"	1 1/32"	13 1/2"	6 1/2"	1 1/4"	7/8"	4 3/4"	1 1/32"	28 GAUGE	5/8"DIA. X 2 1/2"	5 1/4"	4"	4 1/2"	1"	1 1/8"	5/8"	2 1/4"	1 1/32"	3/8"	70
W8X21	3/4"DIA. X 4 1/4"	14"	7"	1 1/2"	1"	5"	1 1/2"	1 3/32"	14"	7"	1 1/2"	1"	5"	1 3/32"	28 GAUGE	3/4"DIA. X 2 3/4"	5 1/4"	6"	7"	1"	1 3/4"	3/4"	3 1/2"	1 3/32"	3/8"	73
W10X22	3/4"DIA. X 4 1/4"	16"	8"	1 1/2"	1"	6"	1 1/2"	1 3/32"	16"	8"	1 1/2"	1"	6"	1 3/32"	28 GAUGE	3/4"DIA. X 2 3/4"	5 3/4"	6"	7"	1"	1 3/4"	3/4"	3 1/2"	1 3/32"	3/8"	119
W10X26	3/4"DIA. X 4 3/4"	16 1/2"	8"	1 1/2"	1"	6"	1 3/4"	1 3/32"	16 1/2"	8"	1 1/2"	1"	6"	1 3/32"	28 GAUGE	3/4"DIA. X 2 3/4"	5 3/4"	6"	7"	1"	1 3/4"	3/4"	3 1/2"	1 3/32"	3/8"	140
W12X26	3/4"DIA. X 4 3/4"	18 1/2"	9"	1 1/2"	1"	7"	1 3/4"	1 3/32"	18 1/2"	9"	1 1/2"	1"	7"	1 3/32"	28 GAUGE	3/4"DIA. X 2 3/4"	6 1/2"	6"	7"	1"	1 3/4"	3/4"	3 1/2"	1 3/32"	3/8"	176
W14X30	1"DIA. X 5"	22"	9"	2"	1 1/2"	6"	2"	1 7/32"	22"	9"	2"	1 1/2"	6"	1 7/32"	28 GAUGE	1"DIA. X 3"	6 3/4"	7"	8"	1 1/4"	2"	1"	4"	1 7/32"	3/8"	205
W16X31	1"DIA. X 5"	24"	9"	2"	1 1/2"	6"	2"	1 7/32"	24"	9"	2"	1 1/2"	6"	1 7/32"	28 GAUGE	1"DIA. X 3 1/4"	5 1/2"	7"	8"	1 1/4"	2"	1"	4"	1 7/32"	3/8"	223
W18X35	1"DIA. X 5"	25"	9"	2"	1 1/2"	6"	2"	1 7/32"	25"	9"	2"	1 1/2"	6"	1 7/32"	28 GAUGE	1"DIA. X 3 1/4"	6"	7"	8"	1 1/4"	2"	1"	4"	1 7/32"	3/8"	243
W18X40	1"DIA. X 5 1/2"	26"	9"	2"	1 1/2"	6"	2 1/4"	1 7/32"	26"	9"	2"	1 1/2"	6"	1 7/32"	28 GAUGE	1"DIA. X 3 3/4"	6"	7"	8"	1 1/4"	2"	1"	4"	1 7/32"	3/8"	278
W21X44	1"DIA. X 5 1/2"	29"	9"	2"	1 1/2"	6"	2 1/2"	1 7/32"	29"	9"	2"	1 1/2"	6"	1 7/32"	28 GAUGE	1"DIA. X 3 3/4"	6 1/2"	7"	8"	1 1/4"	2"	1"	4"	1 7/32"	3/8"	310

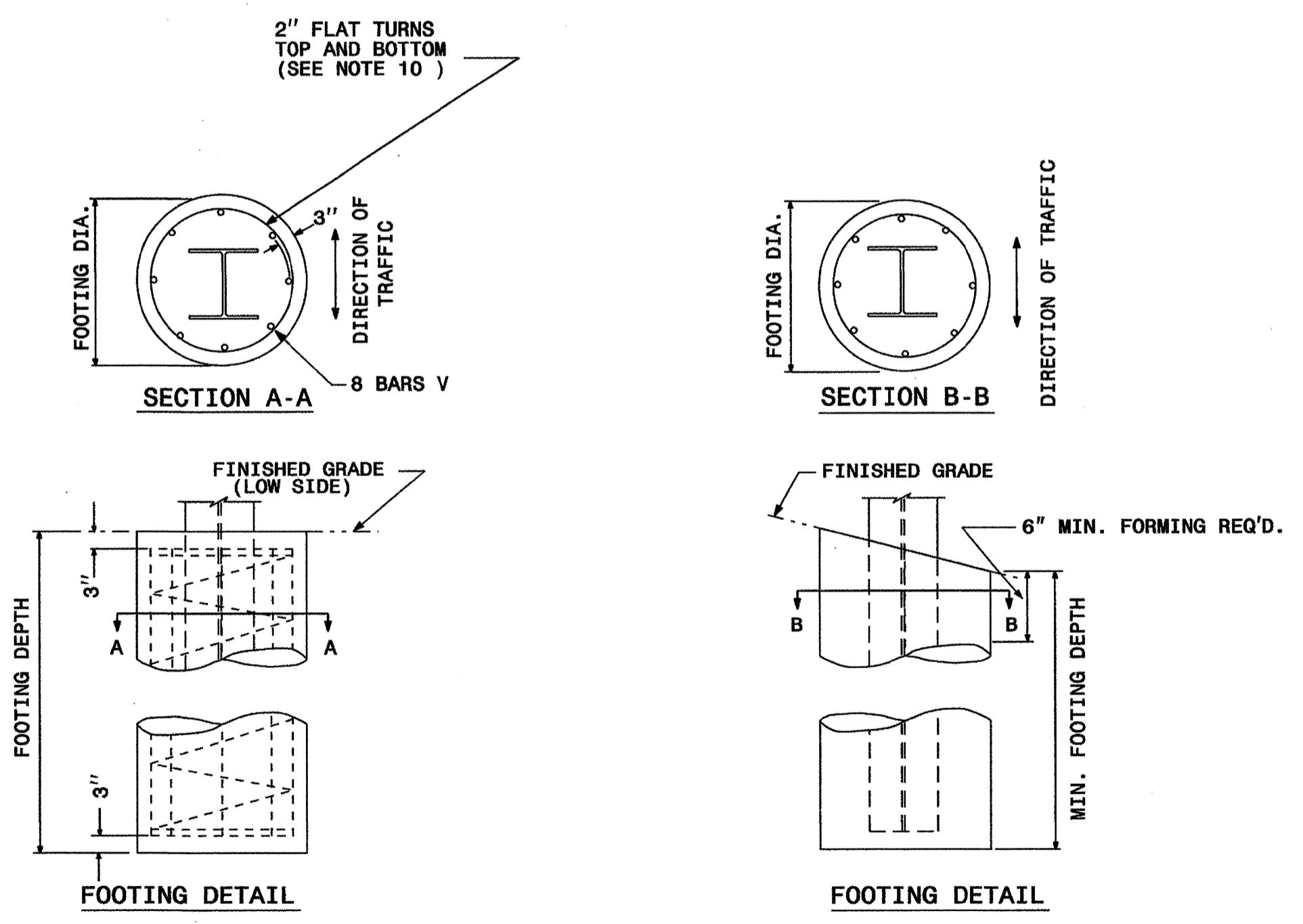

FOOTING DIAMETER	REINFORCEMENT	SPIRAL BAR
1' 6"	8 # 6 BARS	#3 BAR, 6" PITCH
2'	8 # 7 BARS	#3 BAR, 6" PITCH
2' 6"	8 # 9 BARS	#3 BAR, 6" PITCH
3'	8 # 11 BARS	#3 BAR, 6" PITCH
3' 6"	8 # 12 BARS	#3 BAR, 6" PITCH
4'	8 # 14 BARS	#3 BAR, 6" PITCH

* FOUNDATION DIMENSIONS ARE SHOWN IN PLANS

STATE OF NORTH CAROLINA
 DEPT. OF TRANSPORTATION
 DIVISION OF HIGHWAYS
 RALEIGH, N.C.

ENGLISH DETAIL DRAWING FOR
GROUND MOUNTED SIGN SUPPORTS

SHEET 2 OF 3
903D10

**REVISED SIGNING
 ROADWAY STANDARD DRAWING**

08-MAR-2012 11:03 AM C:\Users\Standard\Drawings\Standard Dwg\8-17-11\Revised\0903D10.sgn_sht02.dwg support-1-Revised_Scaled.dwg

APPROVED: *[Signature]*
DATE: 3/19/14

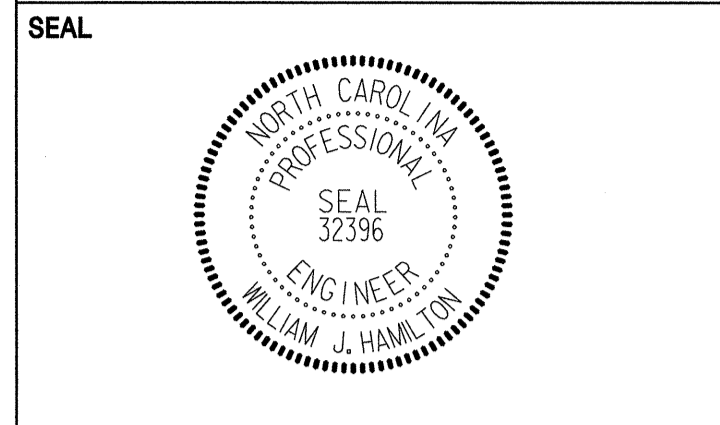

SIGN NO.	SIGN TYPE	SIGN SIZE (in.)			ROADWAY STATION	NO. OF SUP.	BEAM SECTION	SUPPORT TYPE	ATTACH METHOD	MOUNTING METHOD	HORIZ. CLR.* (ft.)	LENGTH (ft.)			LEFT SUPPORT (ft.)			CENTER SUPPORT (ft.)			RIGHT SUPPORT (ft.)			FOOTING DIAMETE (ft.)	FOOTING DEPTH (ft.)	B/A SUPPORT WEIGHTS (lbs.)	SIMPLE SUPPORT WEIGHTS (lbs.)	REINF. FTGS. (c.y.)	PLAIN FTGS. (c.y.)	FIELD VERIFIED SEE NOTE 2 (mm/dd/yy)																						
		w	x	h								SNS HT	MTG HT	EMBED	S	L	TOTAL LENGTH	S	L	TOTAL LENGTH	S	L	TOTAL LENGTH																													
												H	C	MENT																																						
101A	B	108	X	30																																																
101B	A	264	X	90	103+25 -L1-	3	W6x16	BA	1-R	N/A	20.00	7.50	7.00	5.5	0.88	15.38	20.88	1.22	15.72	21.22	0.10	14.60	20.10	1.5	6	1193.77	0.00	1.18	0.00																							
102A	B	108	X	30																																																
102B	A	264	X	108	53+69 -L-	3	W8x18	BA	1-R	N/A	30.00	9.00	7.00	5.5	3.00	19.00	24.50	1.35	17.35	22.85	1.15	17.15	22.65	2	6	1503.19	0.00	2.09	0.00																							
103A	B	108	X	30																																																
103B	A	264	X	90	27+32 -L-	3	W6x16	BA	1-R	N/A	30.00	7.50	7.00	6	3.75	18.25	24.25	2.61	17.11	23.11	1.17	15.67	21.67	1.5	6.5	1303.05	0.00	1.28	0.00																							
201	A	96	X	60	32+41 -L-	2	S4x7.7	BA	N/A	N/A	10.00	5.00	7.00	3.5	0.50	12.50	16.00	0.00	0.00	0.00	0.50	12.50	16.00	1	4	217.93	0.00	0.00	0.23																							
202	A	96	X	60	63+64 -L1-	2	S4x7.7	BA	N/A	N/A	10.00	5.00	7.00	3.5	0.50	12.50	16.00	0.00	0.00	0.00	0.50	12.50	16.00	1	4	217.93	0.00	0.00	0.23																							
203	A	96	X	60	Exit 194 - SB	2	S4x7.7	BA	N/A	N/A	10.00	5.00	7.00	3.5	0.50	12.50	16.00	0.00	0.00	0.00	0.50	12.50	16.00	1.00	4	217.93	0.00	0.00	0.23																							
204	A	96	X	60	Exit 194 - NB	2	S4x7.7	BA	N/A	N/A	10.00	5.00	7.00	3.5	0.50	12.50	16.00	0.00	0.00	0.00	0.50	12.50	16.00	1.00	4	217.93	0.00	0.00	0.23																							
205	A	96	X	60	Exit 190 - SB	2	S4x7.7	BA	N/A	N/A	10.00	5.00	7.00	3.5	0.50	12.50	16.00	0.00	0.00	0.00	0.50	12.50	16.00	1.00	4	217.93	0.00	0.00	0.23																							
206	A	96	X	60	Exit 190 - NB	2	S4x7.7	BA	N/A	N/A	10.00	5.00	7.00	3.5	0.50	12.50	16.00	0.00	0.00	0.00	0.50	12.50	16.00	1.00	4	217.93	0.00	0.00	0.23																							
																							TOTAL																													
																							5307.60																													
																							USE:																													
																							5308																													

- NOTES
- DIMENSION "S" REPRESENTS AN INCREASE (+), OR A DECREASE (-) IN POLE LENGTH, RELATIVE TO THE ELEVATION OF THE EDGE OF PAVEMENT.
 - FIELD VERIFICATIONS SHALL BE REQUIRED FOR ALL SUPPORTS, SEE (*) ARTICLE 903-3. FABRICATORS SHALL BE AISC CERTIFIED IN CATEGORY 1, SEE (*) ARTICLE 1072-1. (*) = N.C.D.O.T. STANDARD SPECIFICATIONS FOR ROADS AND STRUCTURES
 - PLAN LOCATIONS FOR EXISTING UTILITIES ARE BASED ON THE BEST AVAILABLE INFORMATION AND, THEREFORE MAY NOT BE PRECISELY ACCURATE. THEREFORE, IT IS INCUMBENT UPON THE CONTRACTOR TO DETERMINE THE EXACT LOCATION OF UTILITIES BEFORE BEGINNING WORK IN A LOCATION.

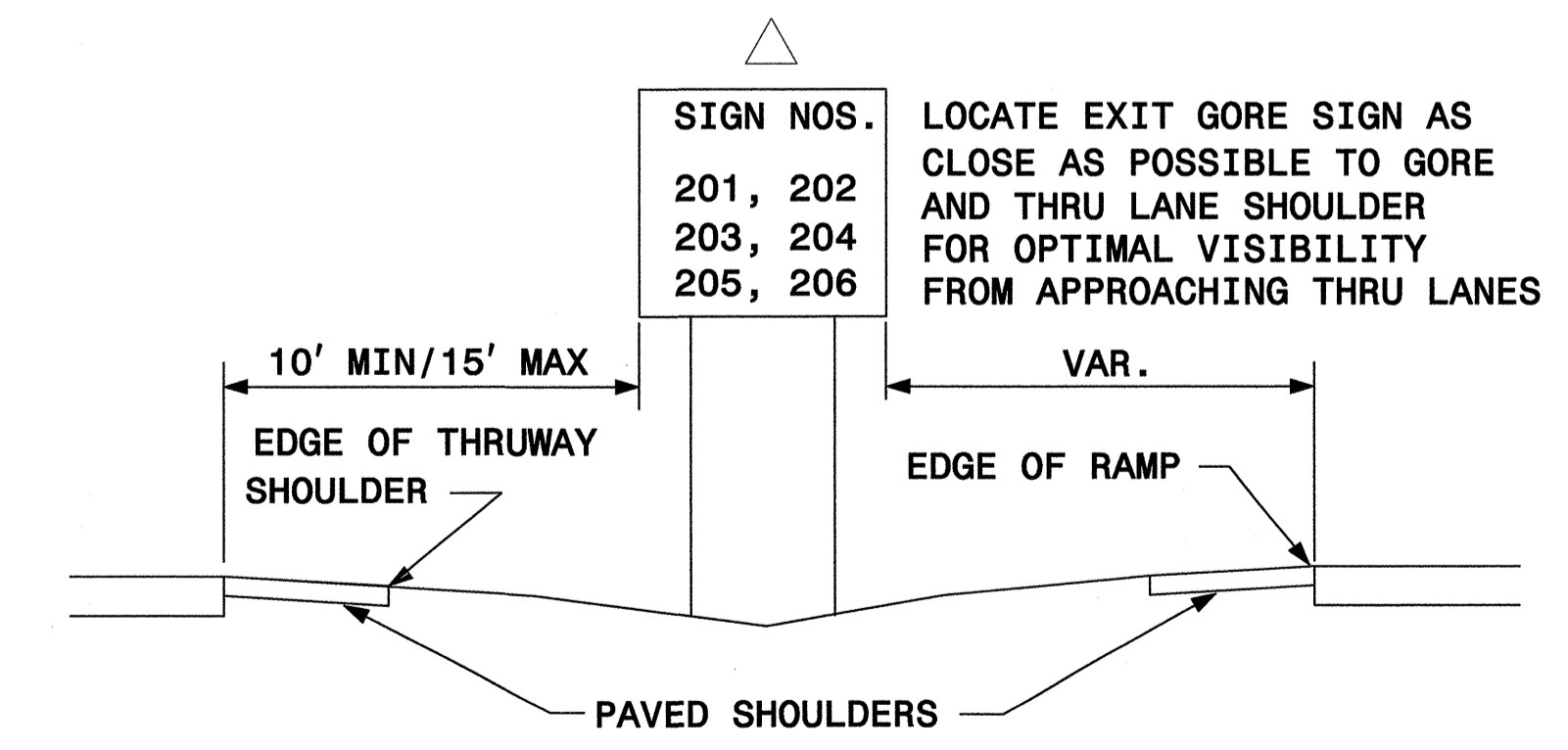
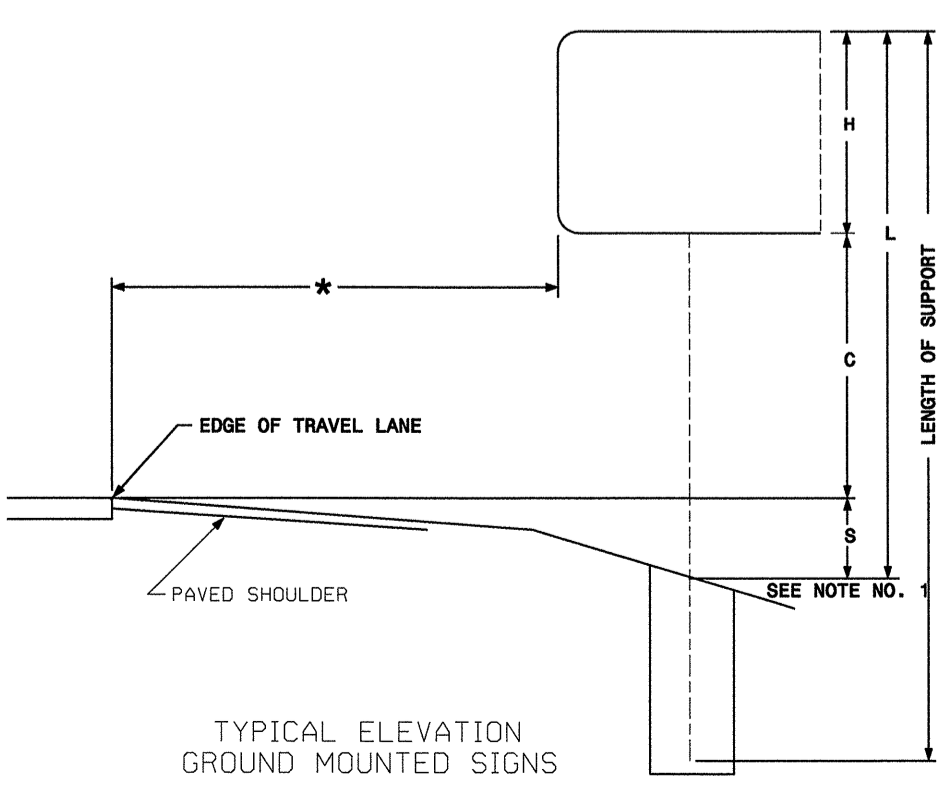

Prepared in the offices of:
RAMEY KEMP ASSOCIATES, INC.
TRANSPORTATION ENGINEERS
8008 Farrington Place, Suite 100
Raleigh, North Carolina 27609
919-877-5118 Tel. 919-878-8418 Fax
www.rameykemp.com

TYPE "A" GROUND MOUNTED SIGNS

TIP NO. R-2612B	SHEET NO. SIGN-4
APPROVED: <i>WJH</i>	
DATE: 3/19/14	
SEAL	
	

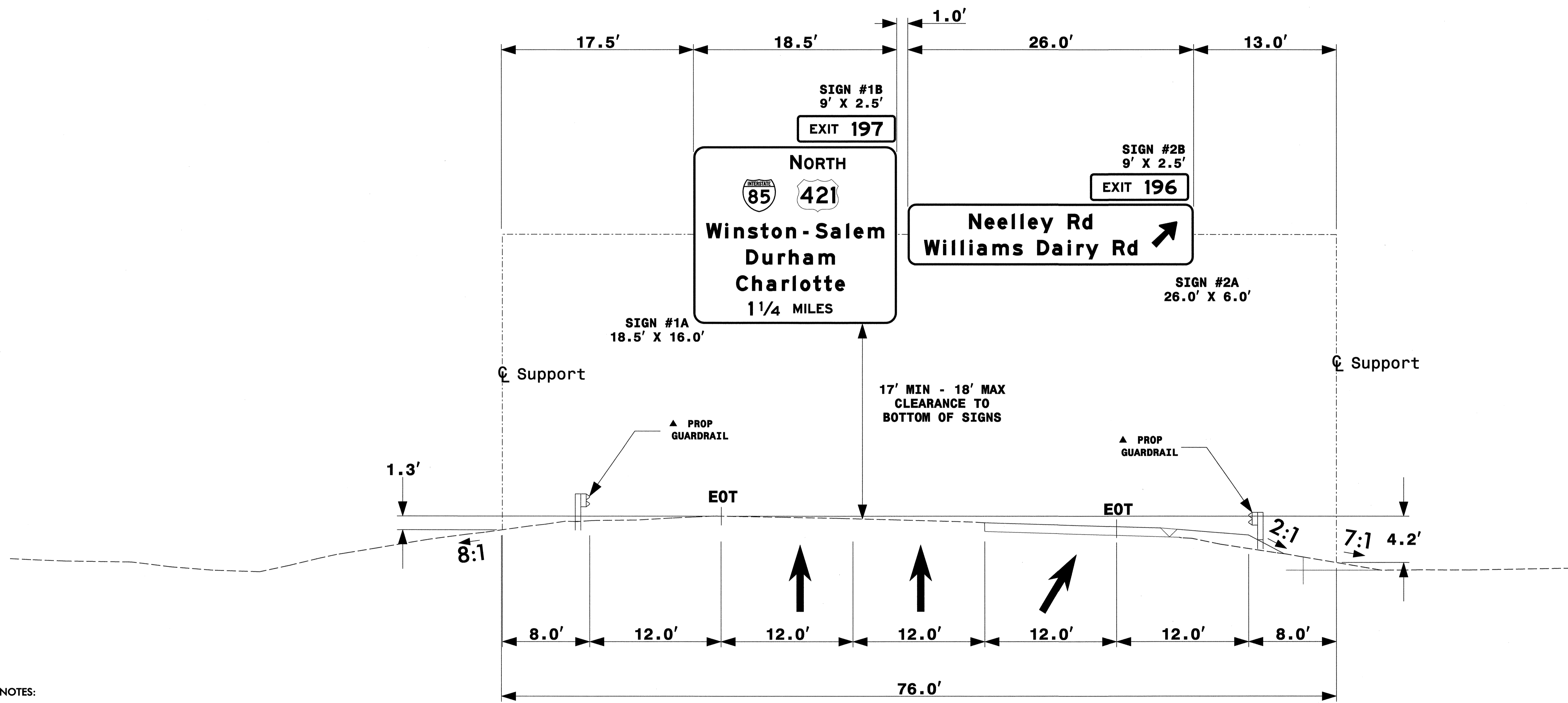

NOTES:

- IF THE CONTRACTOR BIDS ALUMINUM SIGN STRUCTURE, EACH SHALL BE PROVIDED WITH AN APPROVED HIGHWAY TRUSS DAMPER DEVICE IN ACCORDANCE WITH AASHTO SPECIFICATIONS.
- MOUNT SIGNS VERTICALLY CENTERED ON HORIZONTAL MEMBER OF STRUCTURE.
- FIELD VERIFICATION SHALL BE REQUIRED FOR ALL FOOTING ELEVATIONS, PER THE LATEST NCDOT STANDARD SPECIFICATIONS FOR ROADS AND STRUCTURES. PROVIDE FIELD VERIFICATION TO THE SIGNING SECTION.
- THE TOP OF THE FOOTING SHALL EXTEND AT LEAST 6 INCHES AND NOT MORE THAN 24 INCHES ABOVE THE HIGHEST POINT OF THE GROUND SURFACE AT THE FOOTING.
- SIGN HANGERS AND ATTACHMENT HARDWARE SHALL BE PROVIDED AND INSTALLED ON THE ASSEMBLY TO ACCOMMODATE ALL SIGNS SHOWN IN THIS PLAN SHEET.
- DESIGN AND CONSTRUCTION REQUIREMENTS FOR SIGN STRUCTURES SHALL ACCOMMODATE WIND VELOCITY OF 90 M.P.H.

▲ SEE ROADWAY PLANS FOR GUARDRAIL LOCATION

Prepared in the offices of:



RAMEY KEMP ASSOCIATES, INC.
 Transportation Engineers
 6808 Parkwood Place, Suite 100
 Raleigh, North Carolina 27612
 919-872-8116 Tel, 919-875-6416 Fax
 www.rameykemp.com

**OVERHEAD SIGN ASSEMBLY
 AT STA. 73+50 -L1-**

APPROVED: *[Signature]*
DATE: 3/19/14

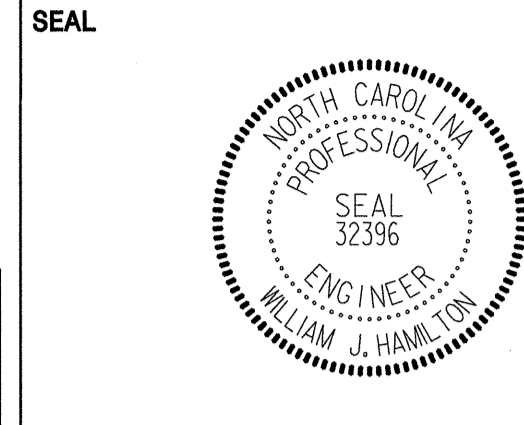

SIGN NUMBER: 1A
TYPE: A
QUANTITY: 1
SIGN WIDTH: 18'-6"
HEIGHT: 16'-0"
TOTAL AREA: 296.0 Sq.Ft.
BORDER TYPE: FLUSH
RECESS: 0"
WIDTH: 2"
RADII: 12"
NO. Z BARS: 6
LENGTH: 214.0

BACKG COLOR: Green
COPY COLOR: White

SYMBOL	X	Y	WID	HT
M1_1	53.7	120	36	36
M1_4	113.2	120	45	36

DESIGN BY: NE BURNS
CHECKED BY: WJ HAMILTON
PROJECT ID: R-2612B
DIV: 7
DATE: Jan 22, 2014

Spacing Factor is 1 unless specified otherwise

LETTER POSITIONS

Letter spacings are to start of next letter

Series/Size	Text	Length
E 2000	N O R T H	56.3
EM 2000	W I N S T O N - S A L E M	194.2
EM 2000	D U R H A M	96.6
EM 2000	C H A R L O T T E	118.6
E 2000	1 1/4 M I L E S	91.6

FILENAME: Nicks Sign Designs NORTH CAROLINA D.O.T. SIGN DETAIL

SIGN NUMBER: 102A
TYPE: A
QUANTITY: 1
SIGN WIDTH: 22'-0"
HEIGHT: 9'-0"
TOTAL AREA: 198.0 Sq.Ft.
BORDER TYPE: FLUSH
RECESS: 0"
WIDTH: 2"
RADII: 12"
NO. Z BARS: 3
LENGTH: 256.0

BACKG COLOR: Green
COPY COLOR: White

SYMBOL	X	Y	WID	HT
AR_Type A	116.4	12.2	22.2	35

DESIGN BY: NE BURNS
CHECKED BY: WJ HAMILTON
PROJECT ID: R-2612B
DIV: 7
DATE: Feb 19, 2014

Spacing Factor is 1 unless specified otherwise

LETTER POSITIONS

Letter spacings are to start of next letter

Series/Size	Text	Length
EM 2000	N e e l l e y R d	134.1
EM 2000	W i l l i a m s D a i r y R d	232.5

FILENAME: Nicks Sign Designs NORTH CAROLINA D.O.T. SIGN DETAIL

SIGN NUMBER: 2A
TYPE: A
QUANTITY: 1
SIGN WIDTH: 26'-0"
HEIGHT: 6'-0"
TOTAL AREA: 156.0 Sq.Ft.
BORDER TYPE: FLUSH
RECESS: 0"
WIDTH: 2"
RADII: 9"
NO. Z BARS: 2
LENGTH: 304.0

BACKG COLOR: Green
COPY COLOR: White

SYMBOL	X	Y	WID	HT
AR_Type A	266.5	22.2	22.2	35

DESIGN BY: NE BURNS
CHECKED BY: WJ HAMILTON
PROJECT ID: R-2612B
DIV: 7
DATE: Mar 13, 2014

Spacing Factor is 1 unless specified otherwise

LETTER POSITIONS

Letter spacings are to start of next letter

Series/Size	Text	Length
EM 2000	N e e l l e y R d	134.1
EM 2000	W i l l i a m s D a i r y R d	232.5

FILENAME: Nicks Sign Designs NORTH CAROLINA D.O.T. SIGN DETAIL

SIGN NUMBER: 101A,103A
TYPE: A
QUANTITY: 2
SIGN WIDTH: 22'-0"
HEIGHT: 7'-6"
TOTAL AREA: 165.0 Sq.Ft.
BORDER TYPE: FLUSH
RECESS: 0"
WIDTH: 2"
RADII: 9"
NO. Z BARS: 3
LENGTH: 256.0

BACKG COLOR: Green
COPY COLOR: White

SYMBOL	X	Y	WID	HT
AR_Type A	116.4	12.2	22.2	35

DESIGN BY: NE BURNS
CHECKED BY: WJ HAMILTON
PROJECT ID: R-2612B
DIV: 7
DATE: Mar 13, 2014

Spacing Factor is 1 unless specified otherwise

LETTER POSITIONS

Letter spacings are to start of next letter

Series/Size	Text	Length
EM 2000	N e e l l e y R d	134.1
EM 2000	W i l l i a m s D a i r y R d	232.5
E 2000	1/2 M I L E	70.1

FILENAME: Nicks Sign Designs NORTH CAROLINA D.O.T. SIGN DETAIL

APPROVED: *WJH*
DATE: 2/20/14

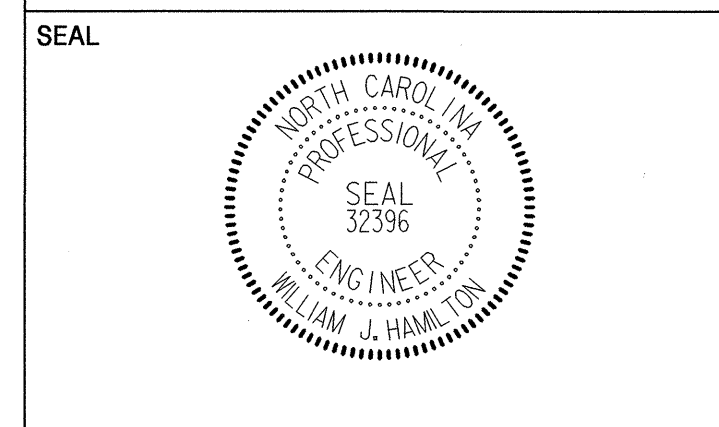

SIGN NUMBER: 108A,110A
TYPE: A
QUANTITY: 2
SIGN WIDTH: 11'-6"
HEIGHT: 9'-6"
TOTAL AREA: 109.3 Sq.Ft.
BORDER TYPE: FLUSH
RECESS: 0"
WIDTH: 2"
RADIUS: 12"
NO. Z BARS: 3
LENGTH: 130.0

BACKG COLOR: Green
COPY COLOR: White

SYMBOL	X	Y	WID	HT
M1-5-2-24-10C	57	82.7	24	24
AR_Type A	57	6.6	19	29.8

MAT'L: 0.125" (3.2 mm) ALUMINUM

DESIGN BY: NE BURNS
PROJECT ID: R-2612B
CHECKED BY: WJ HAMILTON
DIV: 7
DATE: Feb 19, 2014

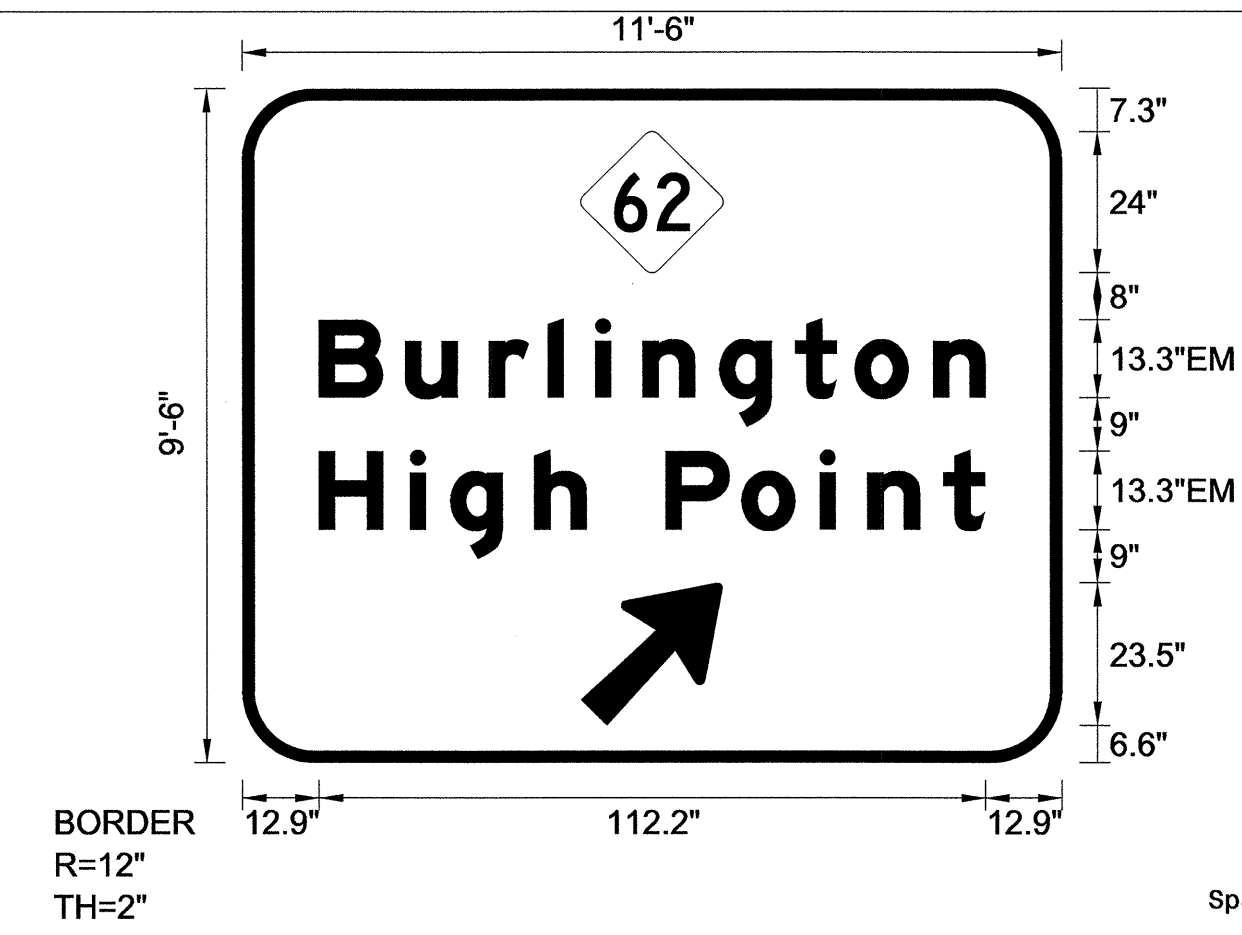

USE NOTES: 1,2,3

- Legend and border(except those that are colored black) shall be direct applied Grade B sheeting.
- Background shall be Grade C reflective sheeting.
- Shields; A, B, and C type arrows shall be on 0.032" (0.8mm) aluminum and demountable.

LETTER POSITIONS

Letter spacings are to start of next letter

	B	u	r	l	i	n	g	t	o	n		Series/Size	
	12.9	14.5	14.1	9.9	8	8	12.9	12.8	10	13.2	8.8	EM 2000	
												112.2	
	H	i	g	h	P	o	i	n	t			EM 2000	
	12.9	15.3	6.8	14.1	8.8	13.3	12.8	13.2	8	12.8	6.9	13	112.1

FILENAME: Nicks Sign Designs NORTH CAROLINA D.O.T. SIGN DETAIL

SIGN NUMBER: 107A,109A
TYPE: A
QUANTITY: 2
SIGN WIDTH: 12'-0"
HEIGHT: 9'-0"
TOTAL AREA: 108.0 Sq.Ft.
BORDER TYPE: FLUSH
RECESS: 0"
WIDTH: 2"
RADIUS: 12"
NO. Z BARS: 3
LENGTH: 136.0

BACKG COLOR: Green
COPY COLOR: White

SYMBOL	X	Y	WID	HT
M1-5-2-24-10C	60	74.7	24	24

MAT'L: 0.125" (3.2 mm) ALUMINUM

DESIGN BY: NE BURNS
PROJECT ID: R-2612B
CHECKED BY: WJ HAMILTON
DIV: 7
DATE: Jan 24, 2014

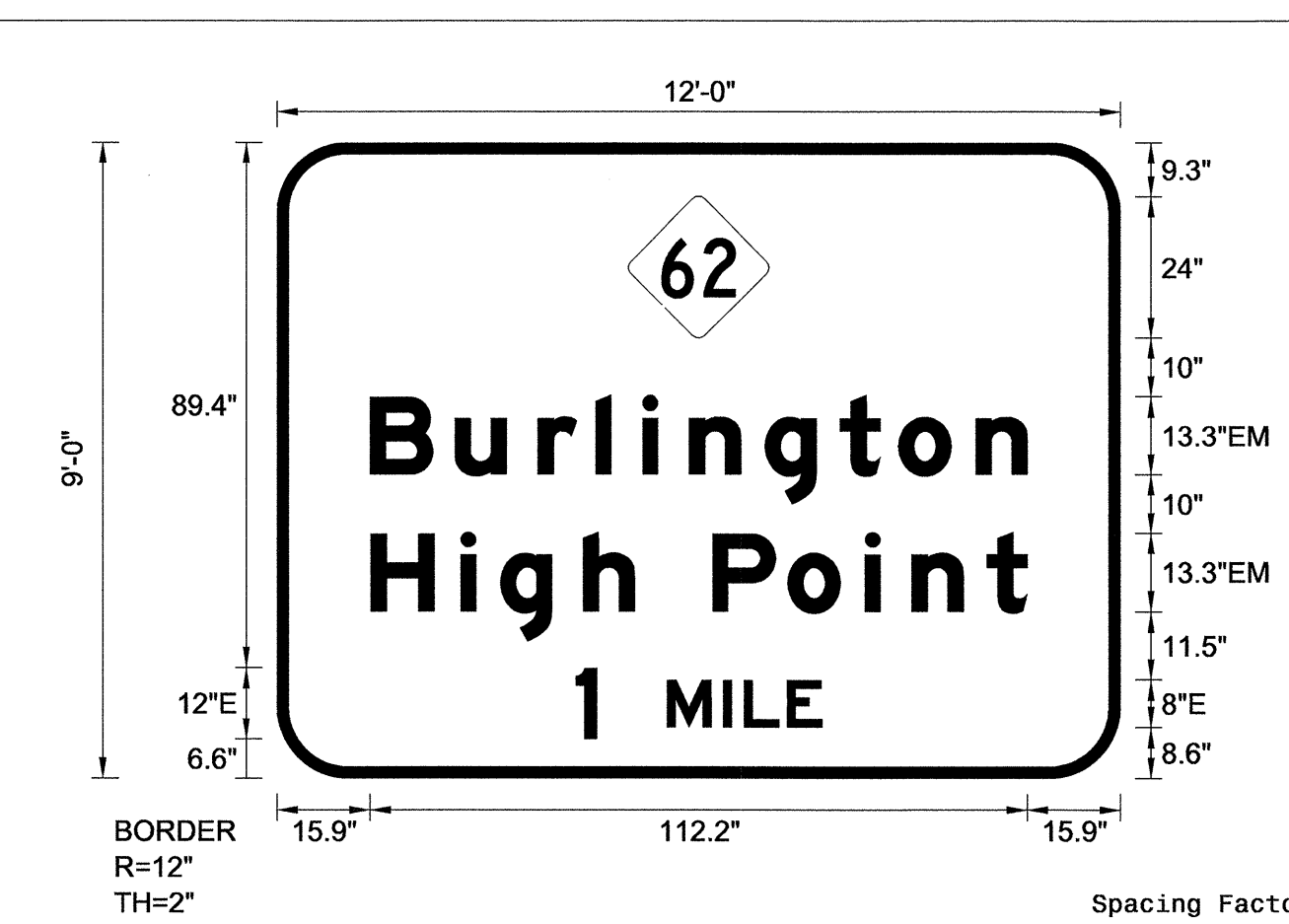

USE NOTES: 1,2,3

- Legend and border(except those that are colored black) shall be direct applied Grade B sheeting.
- Background shall be Grade C reflective sheeting.
- Shields; A, B, and C type arrows shall be on 0.032" (0.8mm) aluminum and demountable.

LETTER POSITIONS

Letter spacings are to start of next letter

	B	u	r	l	i	n	g	t	o	n		Series/Size	
	15.9	14.5	14.1	9.9	8	8	12.9	12.8	10	13.2	8.8	EM 2000	
												112.2	
	H	i	g	h	P	o	i	n	t			EM 2000	
	16	15.3	6.8	14.1	8.8	13.3	12.8	13.2	8	12.8	6.9	15.9	112.1
	1	M	I	L	E							E 2000	
	51	3.6	12	9.6	3.5	7.4	6	50.9				42.1	

FILENAME: Nicks Sign Designs NORTH CAROLINA D.O.T. SIGN DETAIL

APPROVED: *WJH*
 DATE: 3/19/14

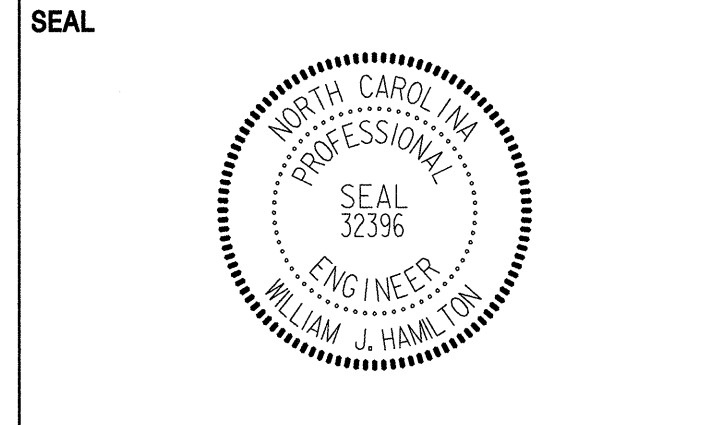

SIGN NUMBER: 301,304
TYPE: D
QUANTITY: 2
SIGN WIDTH: 8'-0"
HEIGHT: 2'-6"
TOTAL AREA: 20.0 Sq.Ft.
BORDER TYPE: FLUSH
RECESS: 0"
WIDTH: 0.75"
RADII: 3"
NO. Z BARS:
LENGTH:

BACKG COLOR: Green
COPY COLOR: White

SYMBOL	X	Y	WID	HT
AR_Type D	20.3	19.7	6	9
AR_Type D	80.3	4.4	6	9

DESIGN BY: NE BURNS
CHECKED BY: WJ HAMILTON
PROJECT ID: R-2612B
DIV: 7
DATE: Mar 13, 2014

BORDER
 R=3"
 TH=0.75"

USE NOTES: 1,2
 1. Legend and border(except those that are colored black) shall be direct applied Grade C sheeting.
 2. Background shall be Grade C reflective sheeting.

Spacing Factor is 1 unless specified otherwise

LETTER POSITIONS

Letter spacings are to start of next letter													Series/Size
													Text Length
N	e	e	l	l	e	y	R	d					D 2000
35.3	5.2	4.1	4.4	2.2	1.9	3.9	4.5	6	4.7	3.6	20.3		40.5
W	i	l	l	i	a	m	s	D	a	i	r	y	D 2000
6.7	6.1	2.2	2.2	2.2	1.9	4.6	6.7	2.8	6	5	4.6	2.2	67.6

FILENAME: Hicks Sign Designs NORTH CAROLINA D.O.T. SIGN DETAIL

SIGN NUMBER: 306
TYPE: D
QUANTITY: 1
SIGN WIDTH: 5'-6"
HEIGHT: 2'-6"
TOTAL AREA: 13.8 Sq.Ft.
BORDER TYPE: FLUSH
RECESS: 0"
WIDTH: 0.75"
RADII: 3"
NO. Z BARS:
LENGTH:

BACKG COLOR: Green
COPY COLOR: White

SYMBOL	X	Y	WID	HT
AR_Type D	7.1	17.3	6	9
AR_Type D	44	3.7	6	9

DESIGN BY: NE BURNS
CHECKED BY: WJ HAMILTON
PROJECT ID: R-2612B
DIV: 7
DATE: Nov 19, 2013

BORDER
 R=3"
 TH=0.75"

USE NOTES: 1,2
 1. Legend and border(except those that are colored black) shall be direct applied Grade C sheeting.
 2. Background shall be Grade C reflective sheeting.

Spacing Factor is 1 unless specified otherwise

LETTER POSITIONS

Letter spacings are to start of next letter													Series/Size
													Text Length
G	r	e	e	n	s	b	o	r	o				D 2000
19.1	5.3	2.8	4.1	4.4	4.3	3.6	4.3	4.6	2.8	3.7	7.1		39.8
L	i	b	e	r	t	y							D 2000
13.1	4.5	2.2	4.3	4.4	2.5	2.6	4.5	28					24.9

FILENAME: Hicks Sign Designs NORTH CAROLINA D.O.T. SIGN DETAIL

SIGN NUMBER: 302
TYPE: D
QUANTITY: 1
SIGN WIDTH: 5'-6"
HEIGHT: 2'-6"
TOTAL AREA: 13.8 Sq.Ft.
BORDER TYPE: FLUSH
RECESS: 0"
WIDTH: 0.75"
RADII: 3"
NO. Z BARS:
LENGTH:

BACKG COLOR: Green
COPY COLOR: White

SYMBOL	X	Y	WID	HT
AR_Type D	14.5	16.6	6	9
AR_Type D	5.6	4.4	6	9

DESIGN BY: NE BURNS
CHECKED BY: WJ HAMILTON
PROJECT ID: R-2612B
DIV: 7
DATE: Nov 19, 2013

BORDER
 R=3"
 TH=0.75"

USE NOTES: 1,2
 1. Legend and border(except those that are colored black) shall be direct applied Grade C sheeting.
 2. Background shall be Grade C reflective sheeting.

Spacing Factor is 1 unless specified otherwise

LETTER POSITIONS

Letter spacings are to start of next letter													Series/Size
													Text Length
L	i	b	e	r	t	y							D 2000
26.6	4.5	2.2	4.3	4.4	2.5	2.6	4.5	14.5					24.9
G	r	e	e	n	s	b	o	r	o				D 2000
20.6	5.3	2.8	4.1	4.4	4.3	3.6	4.3	4.6	2.8	3.7	5.6		39.8

FILENAME: Hicks Sign Designs NORTH CAROLINA D.O.T. SIGN DETAIL

SIGN NUMBER: 305
TYPE: D
QUANTITY: 1
SIGN WIDTH: 4'-6"
HEIGHT: 1'-6"
TOTAL AREA: 6.8 Sq.Ft.
BORDER TYPE: FLUSH
RECESS: 0"
WIDTH: 0.75"
RADII: 1.5"
NO. Z BARS:
LENGTH:

BACKG COLOR: Green
COPY COLOR: White

SYMBOL	X	Y	WID	HT
AR_Type D	7	6	6	9

DESIGN BY: NE BURNS
CHECKED BY: WJ HAMILTON
PROJECT ID: R-2612B
DIV: 7
DATE: Nov 19, 2013

BORDER
 R=1.5"
 TH=0.75"

USE NOTES: 1,2
 1. Legend and border(except those that are colored black) shall be direct applied Grade C sheeting.
 2. Background shall be Grade C reflective sheeting.

Spacing Factor is 1 unless specified otherwise

LETTER POSITIONS

Letter spacings are to start of next letter													Series/Size
													Text Length
L	i	b	e	r	t	y							D 2000
22.1	4.5	2.2	4.3	4.4	2.5	2.6	4.5	7					24.9

FILENAME: Hicks Sign Designs NORTH CAROLINA D.O.T. SIGN DETAIL

APPROVED: *[Signature]*
 DATE: 2/20/14

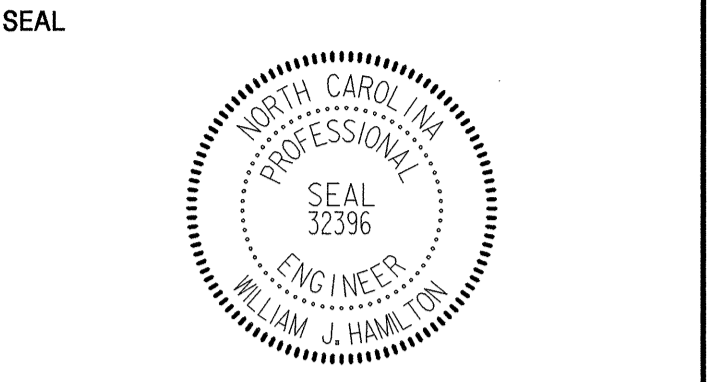

SIGN NUMBER: 107B,108B
 109B,110B
 TYPE: B
 QUANTITY: 4
 SIGN WIDTH: 9'-0"
 HEIGHT: 2'-6"
 TOTAL AREA: 22.5 Sq.Ft.
 BORDER TYPE: FLUSH
 RECESS: 0"
 WIDTH: 0"
 RADII: 3"
 NO. Z BARS: 2
 LENGTH: 100.0

BACKG COLOR: Green
 COPY COLOR: White

DESIGN BY: NE BURNS
 PROJECT ID: R-2612B

CHECKED BY: WJ HAMILTON
 DIV: 7

DATE: Jan 23, 2014

MAT'L: 0.125" (3.2 mm) ALUMINUM

USE NOTES: 1,2
 1. Legend and border(except those that are colored black) shall be direct applied Grade C sheeting.
 2. Background shall be Grade C reflective sheeting.

Spacing Factor is 1 unless specified otherwise

LETTER POSITIONS

Letter spacings are to start of next letter

E	X	I	T	1	9	0	Series/Size
							Text Length
14.5	8.9	10.7	3.5	7.5	15	7.5	E 2000
							80.4

FILENAME: Nicks Sign Designs NORTH CAROLINA D.O.T. SIGN DETAIL

SIGN NUMBER: 104B,105B
 106B,107B
 TYPE: B
 QUANTITY: 4
 SIGN WIDTH: 9'-0"
 HEIGHT: 2'-6"
 TOTAL AREA: 22.5 Sq.Ft.
 BORDER TYPE: FLUSH
 RECESS: 0"
 WIDTH: 0"
 RADII: 3"
 NO. Z BARS: 2
 LENGTH: 100.0

BACKG COLOR: Green
 COPY COLOR: White

DESIGN BY: NE BURNS
 PROJECT ID: R-2612B

CHECKED BY: WJ HAMILTON
 DIV: 7

DATE: Jan 23, 2014

MAT'L: 0.125" (3.2 mm) ALUMINUM

USE NOTES: 1,2
 1. Legend and border(except those that are colored black) shall be direct applied Grade C sheeting.
 2. Background shall be Grade C reflective sheeting.

Spacing Factor is 1 unless specified otherwise

LETTER POSITIONS

Letter spacings are to start of next letter

E	X	I	T	1	9	4	Series/Size
							Text Length
14.5	8.9	10.7	3.5	7.5	15	7.5	E 2000
							81

FILENAME: Nicks Sign Designs NORTH CAROLINA D.O.T. SIGN DETAIL

SIGN NUMBER: 101B,102B
 103B
 TYPE: B
 QUANTITY: 3
 SIGN WIDTH: 9'-0"
 HEIGHT: 2'-6"
 TOTAL AREA: 22.5 Sq.Ft.
 BORDER TYPE: FLUSH
 RECESS: 0"
 WIDTH: 0"
 RADII: 3"
 NO. Z BARS: 2
 LENGTH: 100.0

BACKG COLOR: Green
 COPY COLOR: White

DESIGN BY: NE BURNS
 PROJECT ID: R-2612B

CHECKED BY: WJ HAMILTON
 DIV: 7

DATE: Jan 10, 2014

MAT'L: 0.125" (3.2 mm) ALUMINUM

USE NOTES: 1,2
 1. Legend and border(except those that are colored black) shall be direct applied Grade C sheeting.
 2. Background shall be Grade C reflective sheeting.

Spacing Factor is 1 unless specified otherwise

LETTER POSITIONS

Letter spacings are to start of next letter

E	X	I	T	1	9	6	Series/Size
							Text Length
14.5	8.9	10.7	3.5	7.5	15	7.5	E 2000
							79.9

FILENAME: Nicks Sign Designs NORTH CAROLINA D.O.T. SIGN DETAIL

APPROVED: *[Signature]*

DATE: 2/20/14

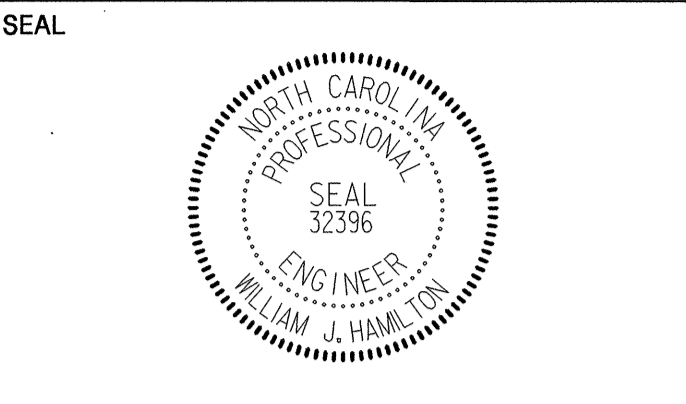

SIGN NUMBER: 205,206 BACKG COLOR: Green
 TYPE: A COPY COLOR: White
 QUANTITY: 2
 SIGN WIDTH: 8'-0" HEIGHT: 5'-0"
 TOTAL AREA: 40.0 Sq.Ft.
 BORDER TYPE: FLUSH
 RECESS: 0"
 WIDTH: 2"
 RADII: 6"
 NO. Z BARS: 2 MAT'L: 0.125" (3.2 mm) ALUMINUM
 LENGTH: 88.0

SYMBOL	X	Y	WID	HT
AR_Type A	61.3	7	18.3	29.3

DESIGN BY: NE BURNS CHECKED BY: WJ HAMILTON DATE: Feb 19, 2014
 PROJECT ID: R-2612B DIV: 7

USE NOTES: 1,2,3
 1. Legend and border(except those that are colored black) shall be direct applied Grade C sheeting.
 2. Background shall be Grade C reflective sheeting.
 3. Shields; A, B, and C type arrows shall be on 0.032" (0.8mm) aluminum and demountable.

Spacing Factor is 1 unless specified otherwise

LETTER POSITIONS

Letter spacings are to start of next letter

	E	X	I	T		Series/Size
						Text Length
	29.5	10.6	13	4.6	8.9	29.5
	1	9	0			
	11.2	9	17.6	15.1	43	
						EM 2000
						37
						E 2000
						41.8

FILENAME: Nicks Sign Designs NORTH CAROLINA D.O.T. SIGN DETAIL

SIGN NUMBER: 203,204 BACKG COLOR: Green
 TYPE: A COPY COLOR: White
 QUANTITY: 2
 SIGN WIDTH: 8'-0" HEIGHT: 5'-0"
 TOTAL AREA: 40.0 Sq.Ft.
 BORDER TYPE: FLUSH
 RECESS: 0"
 WIDTH: 2"
 RADII: 6"
 NO. Z BARS: 2 MAT'L: 0.125" (3.2 mm) ALUMINUM
 LENGTH: 88.0

SYMBOL	X	Y	WID	HT
AR_Type A	61.3	7	18.3	29.3

DESIGN BY: NE BURNS CHECKED BY: WJ HAMILTON DATE: Feb 19, 2014
 PROJECT ID: R-2612B DIV: 7

USE NOTES: 1,2,3
 1. Legend and border(except those that are colored black) shall be direct applied Grade C sheeting.
 2. Background shall be Grade C reflective sheeting.
 3. Shields; A, B, and C type arrows shall be on 0.032" (0.8mm) aluminum and demountable.

Spacing Factor is 1 unless specified otherwise

LETTER POSITIONS

Letter spacings are to start of next letter

	E	X	I	T		Series/Size
						Text Length
	29.5	10.6	13	4.6	8.9	29.5
	1	9	4			
	10.5	9	16.6	16.9	43	
						EM 2000
						37
						E 2000
						42.5

FILENAME: Nicks Sign Designs NORTH CAROLINA D.O.T. SIGN DETAIL

SIGN NUMBER: 201,202 BACKG COLOR: Green
 TYPE: A COPY COLOR: White
 QUANTITY: 2
 SIGN WIDTH: 8'-0" HEIGHT: 5'-0"
 TOTAL AREA: 40.0 Sq.Ft.
 BORDER TYPE: FLUSH
 RECESS: 0"
 WIDTH: 2"
 RADII: 6"
 NO. Z BARS: 2 MAT'L: 0.125" (3.2 mm) ALUMINUM
 LENGTH: 88.0

SYMBOL	X	Y	WID	HT
AR_Type A	61.3	7	18.3	29.3

DESIGN BY: NE BURNS CHECKED BY: WJ HAMILTON DATE: Feb 19, 2014
 PROJECT ID: R-2612B DIV: 7

USE NOTES: 1,2,3
 1. Legend and border(except those that are colored black) shall be direct applied Grade C sheeting.
 2. Background shall be Grade C reflective sheeting.
 3. Shields; A, B, and C type arrows shall be on 0.032" (0.8mm) aluminum and demountable.

Spacing Factor is 1 unless specified otherwise

LETTER POSITIONS

Letter spacings are to start of next letter

	E	X	I	T		Series/Size
						Text Length
	29.5	10.6	13	4.6	8.9	29.5
	1	9	6			
	11.7	9	17.6	14.6	43	
						EM 2000
						37
						E 2000
						41.2

FILENAME: Nicks Sign Designs NORTH CAROLINA D.O.T. SIGN DETAIL

SIGN NUMBER: 303 BACKG COLOR: Green
 TYPE: D COPY COLOR: White
 QUANTITY: 1
 SIGN WIDTH: 5'-6" HEIGHT: 1'-6"
 TOTAL AREA: 8.3 Sq.Ft.
 BORDER TYPE: FLUSH
 RECESS: 0"
 WIDTH: 1"
 RADII: 1.5"
 NO. Z BARS: MAT'L: 0.125" (3.2 mm) ALUMINUM
 LENGTH:

SYMBOL	X	Y	WID	HT
AR_Type D	51.4	6	6	9

DESIGN BY: NE BURNS CHECKED BY: WJ HAMILTON DATE: Nov 19, 2013
 PROJECT ID: R-2612B DIV: 7

USE NOTES: 1,2
 1. Legend and border(except those that are colored black) shall be direct applied Grade C sheeting.
 2. Background shall be Grade C reflective sheeting.

Spacing Factor is 1 unless specified otherwise

LETTER POSITIONS

Letter spacings are to start of next letter

	G	r	e	e	n	s	b	o	r	o		Series/Size
												Text Length
	5.6	5.3	2.8	4.1	4.4	4.3	3.6	4.3	4.6	2.8	3.7	20.6
												D 2000
												39.8

FILENAME: Nicks Sign Designs NORTH CAROLINA D.O.T. SIGN DETAIL

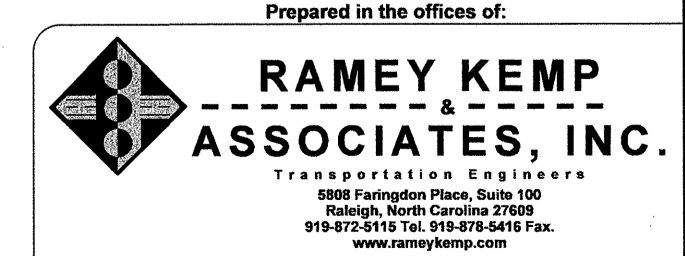

SIGN DETAIL SHEET

APPROVED: *[Signature]*
 DATE: 3/19/14

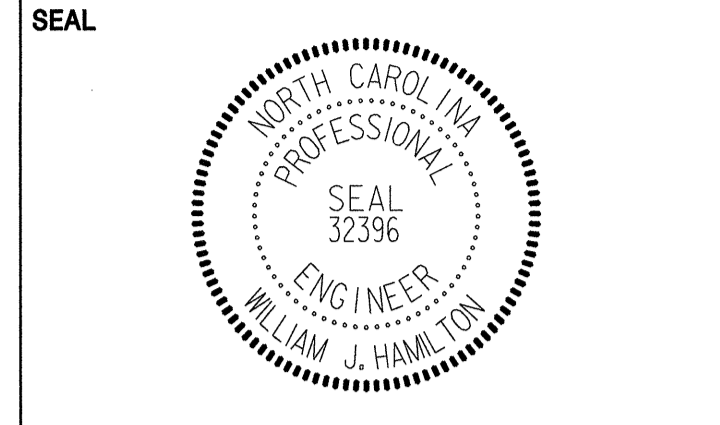

SIGN NUMBER: 602 BACKG COLOR: Green
 TYPE: OVERLAY COPY COLOR: White
 QUANTITY: 1
 SIGN WIDTH: 11'-0" HEIGHT: 2'-0"
 TOTAL AREA: 22.0 Sq.Ft.
 BORDER TYPE: RECESS: 0"
 WIDTH: 0" RADIUS: 0"
 NO. Z BARS: MAT'L: 0.063" (1.6 mm) ALUMINUM
 LENGTH:

DESIGN BY: NE BURNS CHECKED BY: WJ HAMILTON DATE: Mar 13, 2014
 PROJECT ID: R-2612B DIV: 7

USE NOTES: 1,2
 1. Legend and border(except those that are colored black) shall be direct applied Grade C sheeting.
 2. Background shall be Grade C reflective sheeting.

Spacing Factor is 1 unless specified otherwise

LETTER POSITIONS

Letter spacings are to start of next letter											Series/Size Text Length
	1/2	M	I	L	E						E 2000
	31	22	15	12	4.4	9.2	7.5	31			70.1

FILENAME: Nicko Sign Designs NORTH CAROLINA D.O.T. SIGN DETAIL

SIGN NUMBER: 601 BACKG COLOR: Green
 TYPE: OVERLAY COPY COLOR: White
 QUANTITY: 1
 SIGN WIDTH: 11'-6" HEIGHT: 2'-0"
 TOTAL AREA: 23.0 Sq.Ft.
 BORDER TYPE: RECESS: 0"
 WIDTH: 0" RADIUS: 0"
 NO. Z BARS: MAT'L: 0.063" (1.6 mm) ALUMINUM
 LENGTH:

DESIGN BY: NE BURNS CHECKED BY: WJ HAMILTON DATE: Mar 13, 2014
 PROJECT ID: R-2612B DIV: 7

USE NOTES: 1,2
 1. Legend and border(except those that are colored black) shall be direct applied Grade C sheeting.
 2. Background shall be Grade C reflective sheeting.

Spacing Factor is 1 unless specified otherwise

LETTER POSITIONS

Letter spacings are to start of next letter											Series/Size Text Length
	3/4	M	I	L	E						E 2000
	32.5	25	15	12	4.4	9.2	7.5	32.5			73.1

FILENAME: Nicko Sign Designs NORTH CAROLINA D.O.T. SIGN DETAIL

SIGN NUMBER: 19 BACKG COLOR: Green
 TYPE: B COPY COLOR: White
 QUANTITY: 1
 SIGN WIDTH: 9'-0" HEIGHT: 2'-0"
 TOTAL AREA: 22.5 Sq.Ft.
 BORDER TYPE: FLUSH RECESS: 0"
 WIDTH: 0" RADIUS: 3"
 NO. Z BARS: 2 MAT'L: 0.125" (3.2 mm) ALUMINUM
 LENGTH: 100.0

DESIGN BY: NE BURNS CHECKED BY: WJ HAMILTON DATE: Jan 24, 2014
 PROJECT ID: R-2612B DIV: 7

USE NOTES: 1,2
 1. Legend and border(except those that are colored black) shall be direct applied Grade A sheeting.
 2. Background shall be Grade C reflective sheeting.

Spacing Factor is 1 unless specified otherwise

LETTER POSITIONS

Letter spacings are to start of next letter											Series/Size Text Length
	E	X	I	T	1	9	7				E 2000
	14.5	8.9	10.7	3.5	7.5	15	7.5	13.5	12.1	14.5	79

FILENAME: Nicko Sign Designs NORTH CAROLINA D.O.T. SIGN DETAIL

SIGN NUMBER: 28 BACKG COLOR: Green
 TYPE: B COPY COLOR: White
 QUANTITY: 1
 SIGN WIDTH: 9'-0" HEIGHT: 2'-0"
 TOTAL AREA: 22.5 Sq.Ft.
 BORDER TYPE: FLUSH RECESS: 0"
 WIDTH: 0" RADIUS: 3"
 NO. Z BARS: 2 MAT'L: 0.125" (3.2 mm) ALUMINUM
 LENGTH: 100.0

DESIGN BY: NE BURNS CHECKED BY: WJ HAMILTON DATE: Jan 24, 2014
 PROJECT ID: R-2612B DIV: 7

USE NOTES: 1,2
 1. Legend and border(except those that are colored black) shall be direct applied Grade A sheeting.
 2. Background shall be Grade C reflective sheeting.

Spacing Factor is 1 unless specified otherwise

LETTER POSITIONS

Letter spacings are to start of next letter											Series/Size Text Length
	E	X	I	T	1	9	6				E 2000
	14.5	8.9	10.7	3.5	7.5	16	7.5	14.7	12.2	13.5	80

FILENAME: Nicko Sign Designs NORTH CAROLINA D.O.T. SIGN DETAIL

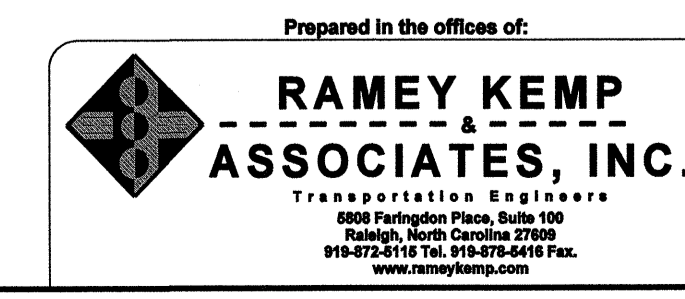

SIGN DETAIL SHEET

APPROVED: *[Signature]*
DATE: 3/19/14

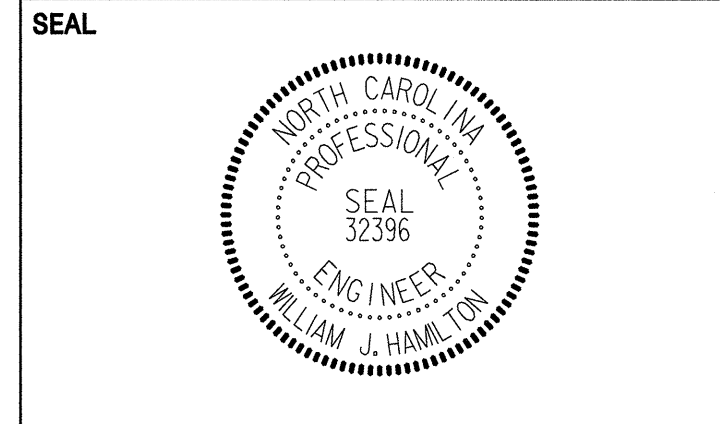

401 QUANTITY REQ'D 8

36 X 36
R1-1

ONE "U" POST PER SIGN

406 QUANTITY REQ'D 2

54 X 18
R6-1 (L)

TWO "U" POSTS PER SIGN

411 QUANTITY REQ'D 4

30 X 36
W1-8

INSTALL ON TWO "U" POSTS PER SIGN SPACED APPROX. 24 INCHES APART ON SUPPORT CENTERS. INSTALL 28 INCH HORIZ. CROSS BRACING LEAVING 1 INCH MARGIN FROM LEFT AND RIGHT EDGES.

INSTALLATION HEIGHT: BOTTOM OF SIGN SHALL BE 4 FEET ABOVE THE EDGE OF TRAVEL LANE ELEVATION (LEFT EDGELINE OF RAMP). SPACE 40' APART.

ALL OTHER PORTIONS OF ROADWAY STANDARD DRAWING 904.50 APPLY.

SEE GENERAL NOTE ON SHEET SIGN-1.

501 508

1 - 21" X 15"
1 - 30" X 24"

ONE "U" POST PER SIGN

506

1 - 30" X 15"
1 - 45" X 36"

TWO "U" POSTS PER SIGN

402 QUANTITY REQ'D 2

48 X 48
W4-1 (R)

TWO "U" POSTS PER SIGN

407 QUANTITY REQ'D 3

36 X 48
R2-1

TWO "U" POSTS PER SIGN

412 QUANTITY REQ'D 1

30 X 30
W14-2

ONE "U" POST PER SIGN

502

2 - 24" X 12"
2 - 30" X 24"
2 - 21" X 15"

TWO "U" POSTS PER SIGN

507

1 - 30" X 15"
1 - 45" X 36"

TWO "U" POSTS PER SIGN

403 QUANTITY REQ'D 4

36 X 36
R5-1

ONE "U" POST PER SIGN

408 QUANTITY REQ'D 4

30 X 36
R2-1

ONE "U" POST PER SIGN

413 QUANTITY REQ'D 2

30 X 30
W3-1

ONE "U" POST PER SIGN

503

1 - 24" X 12"
1 - 30" X 24"
1 - 21" X 15"

ONE "U" POST PER SIGN

404 QUANTITY REQ'D 4

36 X 24
R5-1a

ONE "U" POST PER SIGN

409 QUANTITY REQ'D 1

36 X 48
W13-3

TWO "U" POSTS PER SIGN

414 QUANTITY REQ'D 6

18 X 18
OM4-1

ONE "U" POST PER SIGN

504

1 - 24" X 12"
1 - 30" X 24"
1 - 21" X 15"

ONE "U" POST PER SIGN

405 QUANTITY REQ'D 2

54 X 18
R6-1 (R)

TWO "U" POSTS PER SIGN
MOUNTED BACK TO BACK WITH SIGN
406 IN 2 INSTALLATIONS

410 QUANTITY REQ'D 1

36 X 48
W13-2

TWO "U" POSTS PER SIGN

411 QUANTITY REQ'D 4

30 X 36
W1-8

INSTALL ON TWO "U" POSTS PER SIGN SPACED APPROX. 24 INCHES APART ON SUPPORT CENTERS. INSTALL 28 INCH HORIZ. CROSS BRACING LEAVING 1 INCH MARGIN FROM LEFT AND RIGHT EDGES.

INSTALLATION HEIGHT: BOTTOM OF SIGN SHALL BE 4 FEET ABOVE THE EDGE OF TRAVEL LANE ELEVATION (LEFT EDGELINE OF RAMP). SPACE 40' APART.

ALL OTHER PORTIONS OF ROADWAY STANDARD DRAWING 904.50 APPLY.

SEE GENERAL NOTE ON SHEET SIGN-1.

505

2 - 24" X 12"
2 - 30" X 24"
2 - 21" X 15"

TWO "U" POSTS PER SIGN

Prepared in the offices of:
RAMEY KEMP ASSOCIATES, INC.
Transportation Engineers
6800 Farrington Place, Suite 100
Raleigh, North Carolina 27619
919-872-2610 Fax: 919-872-2410 Fax
www.rkeng.com

TYPE "E" AND "F" SIGNS

APPROVED: *[Signature]*
 DATE: 2/19/14

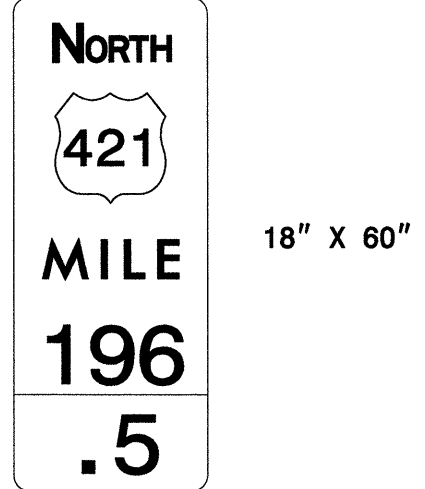
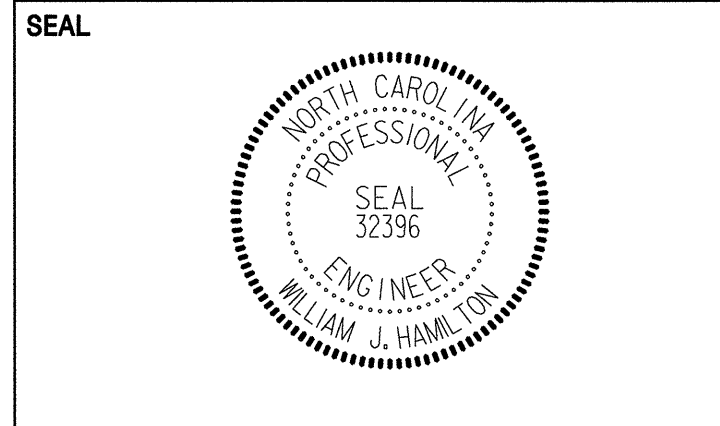

ONE "U" POST PER SIGN

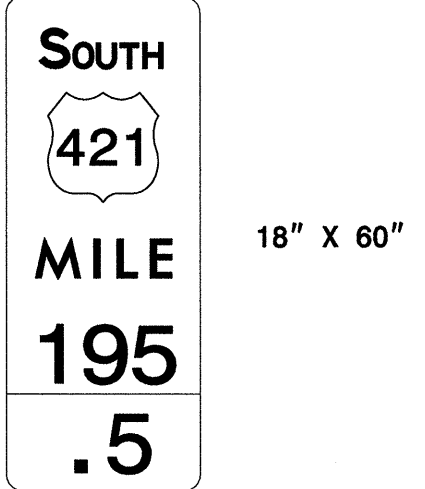

ONE "U" POST PER SIGN

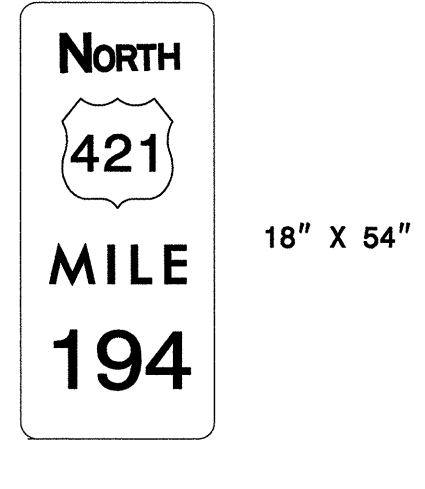

ONE "U" POST PER SIGN

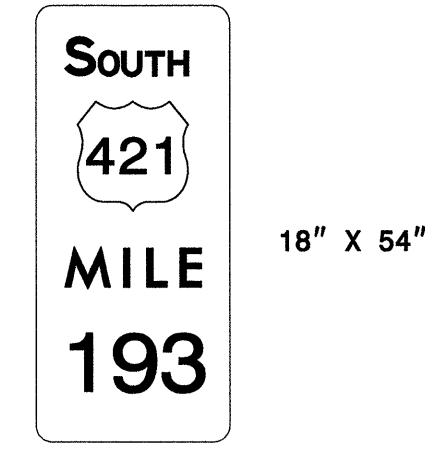

ONE "U" POST PER SIGN

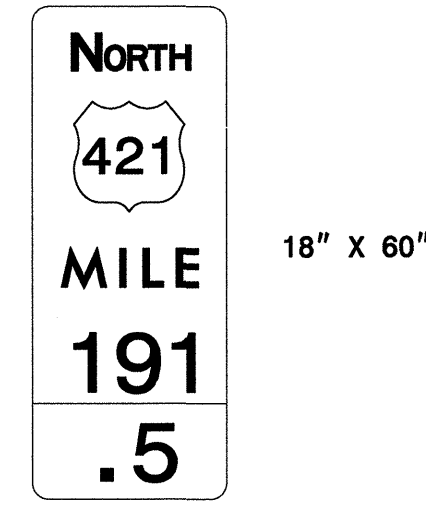

ONE "U" POST PER SIGN

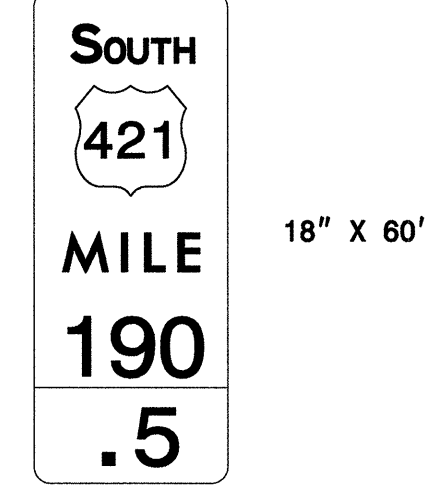

ONE "U" POST PER SIGN

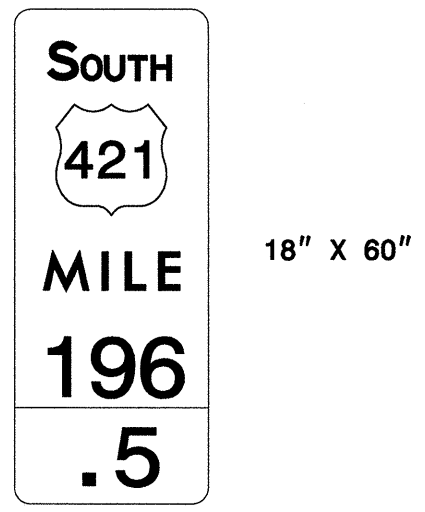

ONE "U" POST PER SIGN

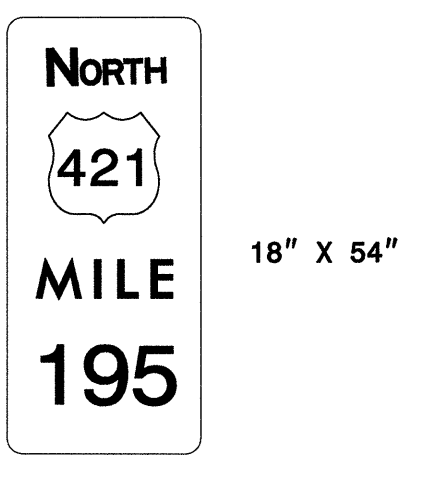

ONE "U" POST PER SIGN

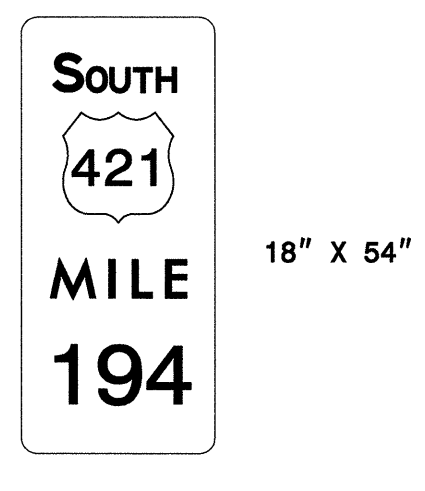

ONE "U" POST PER SIGN

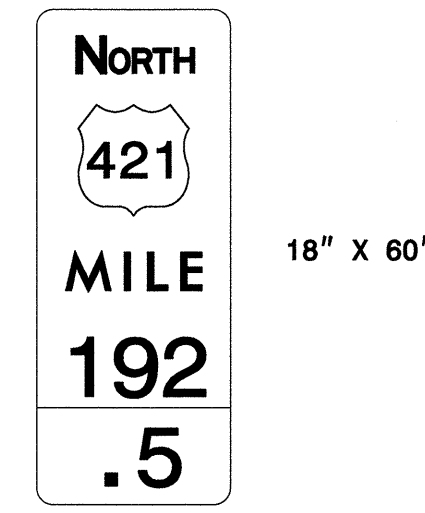

ONE "U" POST PER SIGN

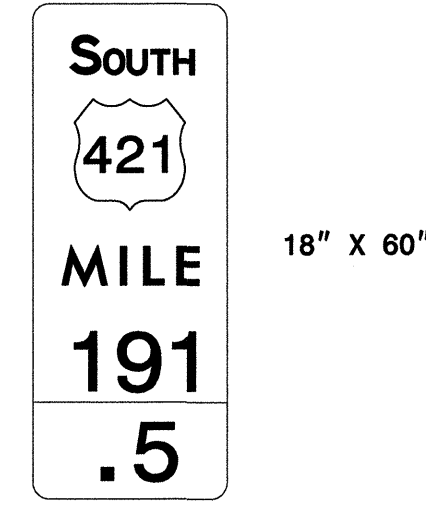

ONE "U" POST PER SIGN

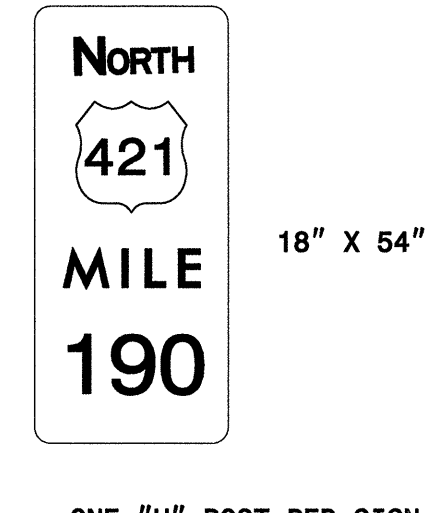

ONE "U" POST PER SIGN

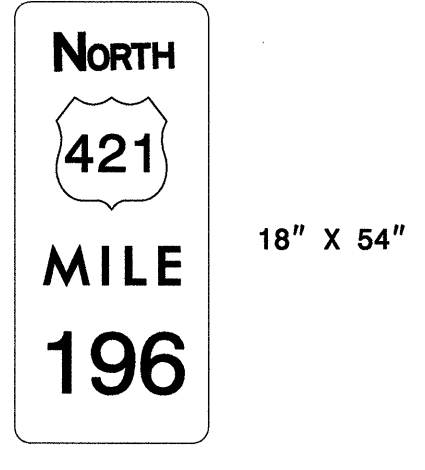

ONE "U" POST PER SIGN

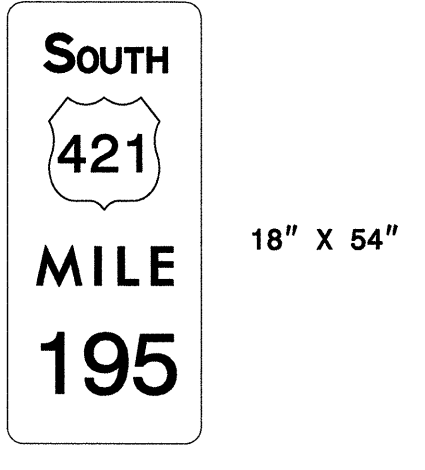

ONE "U" POST PER SIGN

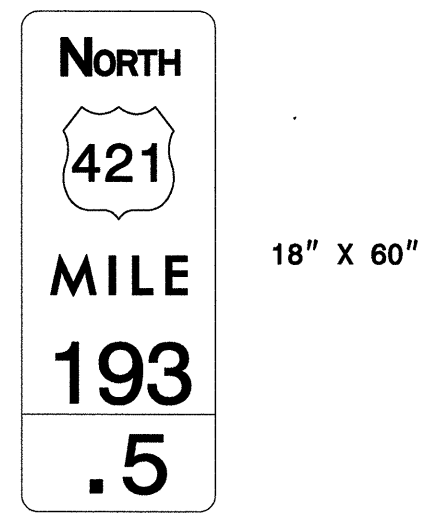

ONE "U" POST PER SIGN

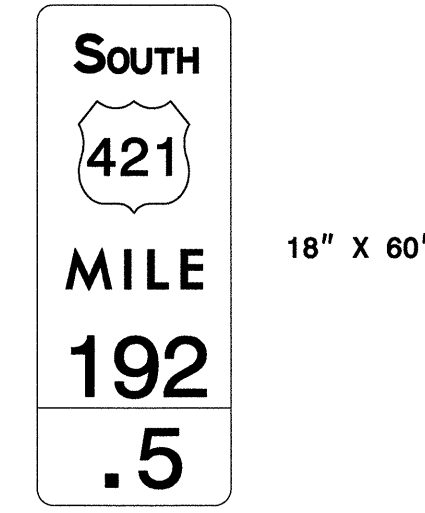

ONE "U" POST PER SIGN

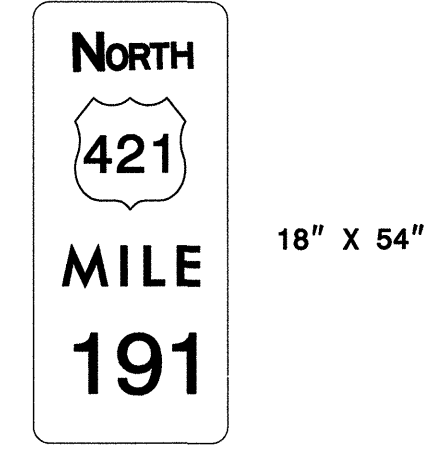

ONE "U" POST PER SIGN

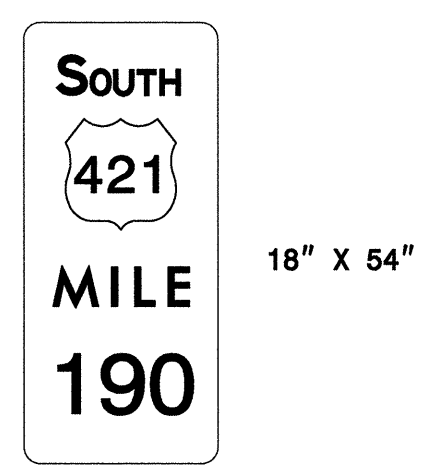

ONE "U" POST PER SIGN

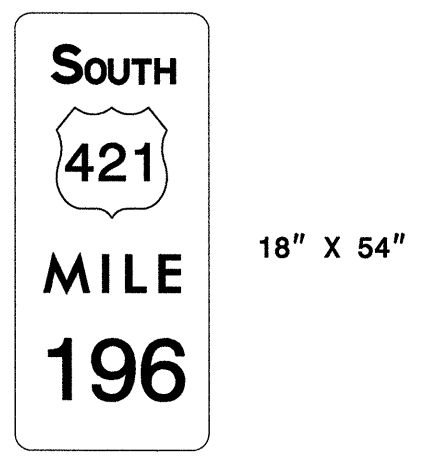

ONE "U" POST PER SIGN

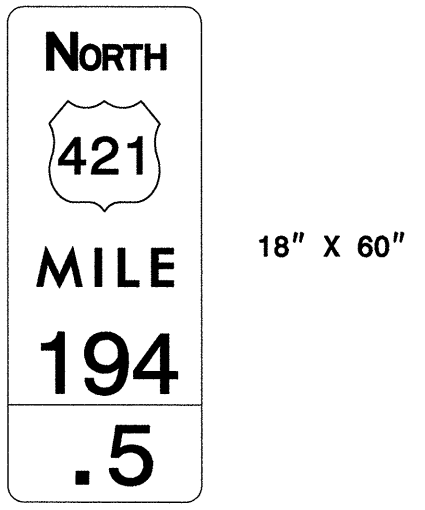

ONE "U" POST PER SIGN

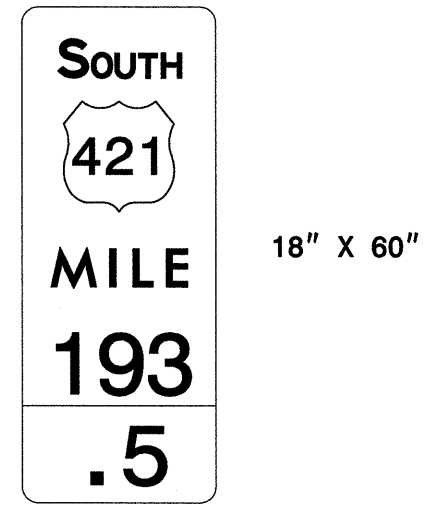

ONE "U" POST PER SIGN

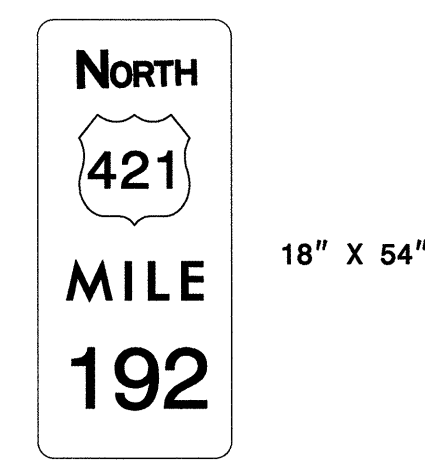

ONE "U" POST PER SIGN

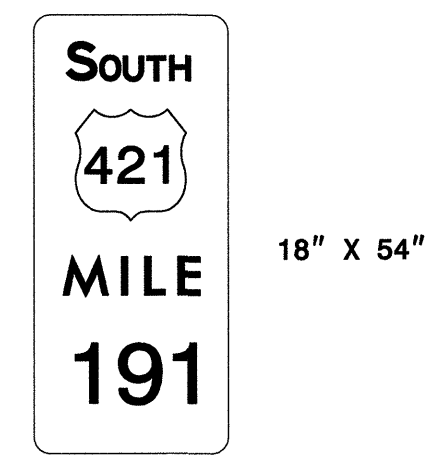

ONE "U" POST PER SIGN

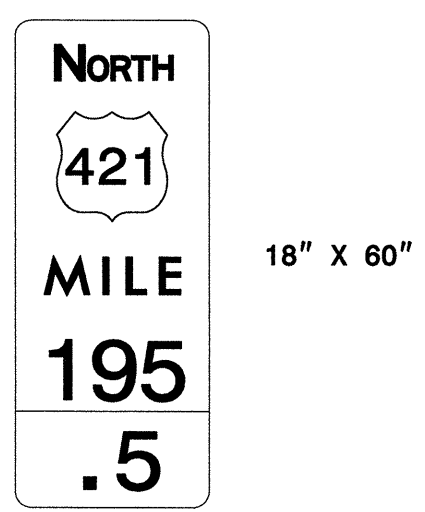

ONE "U" POST PER SIGN

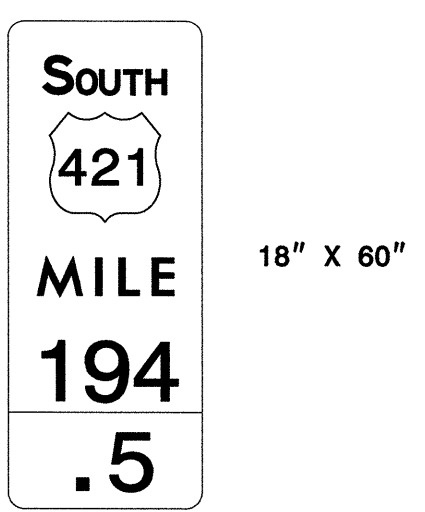

ONE "U" POST PER SIGN

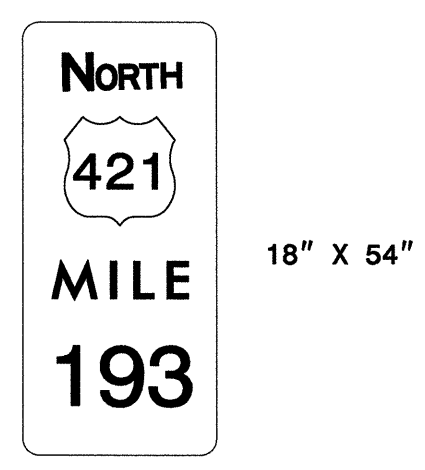

ONE "U" POST PER SIGN

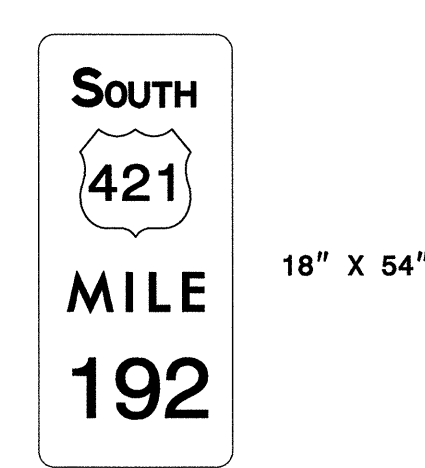

ONE "U" POST PER SIGN

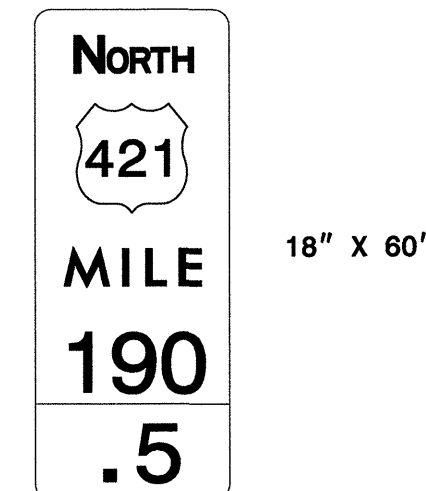

ONE "U" POST PER SIGN

STANDARD MILEMARKER DESIGNS

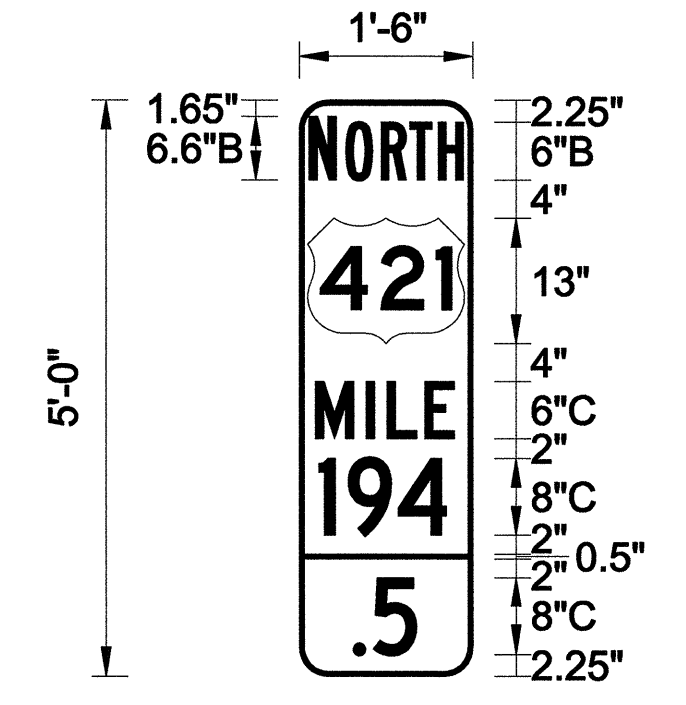

BORDER
 R=1.5"
 TH=0.5"

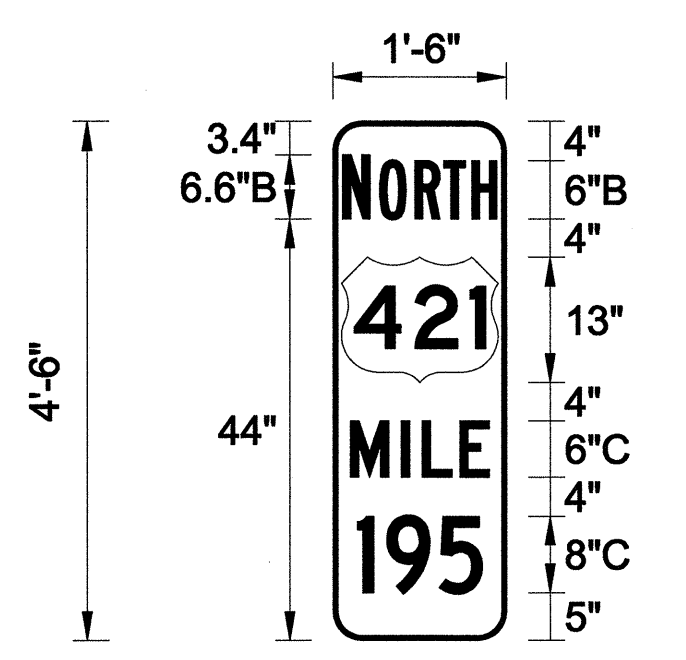

BORDER
 R=1.5"
 TH=0.5"

INSTALLATION NOTE:
 INSTALL ON 3 LB. U-CHANNEL POST 4' ABOVE
 EDGE OF TRAVEL LANE (EDGELINE) ELEVATION.
 INSTALL AT SHOULDER POINT OR MAX OF 15'
 FROM EDGE OF TRAVEL LANE, UNLESS
 OTHERWISE APPROVED BY ENGINEER.

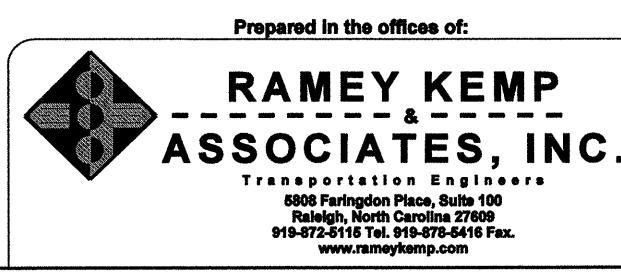

MILEMARKER SIGNS

TIP NO. R-2612B	SHEET NO. SIGN-13
APPROVED: <i>WJK</i>	
DATE: 3/19/14	
SEAL	

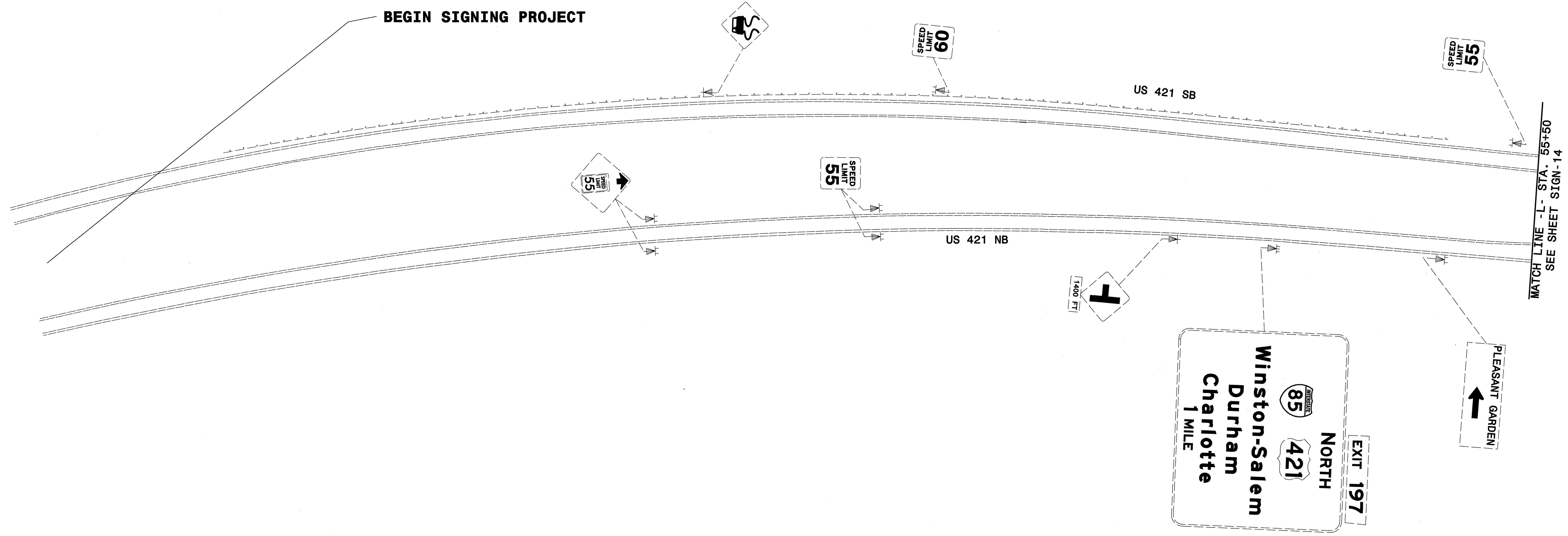

NOTE: REMOVE AND DISPOSE OF EXISTING SIGNS WITHIN PROJECT AREA, UNLESS OTHERWISE NOTED.

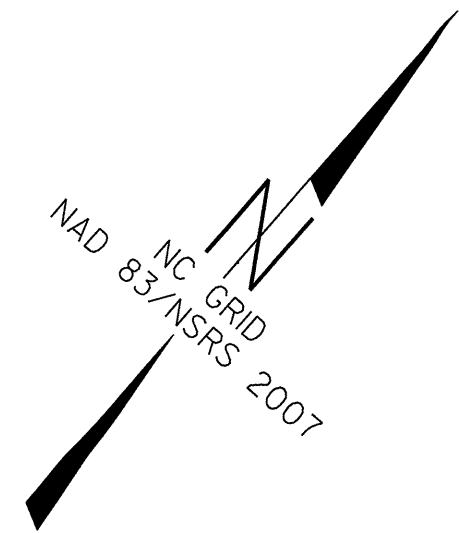

Prepared in the offices of:
RAMEY KEMP & ASSOCIATES, INC.
 Transportation Engineers
 600 Farrington Place, Suite 100
 Raleigh, North Carolina 27609
 919-872-2115 Tel. 919-872-8416 Fax.
 www.rameykemp.com

EXISTING SIGNING DETAIL

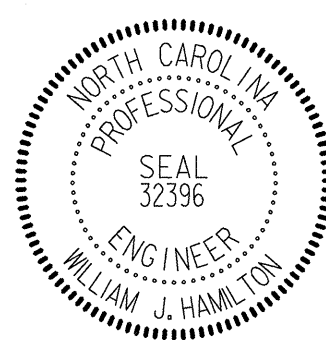
TIP NO. R-2612B	SHEET NO. SIGN-14
APPROVED: <i>[Signature]</i>	
DATE: 2/20/14	
SEAL	
	

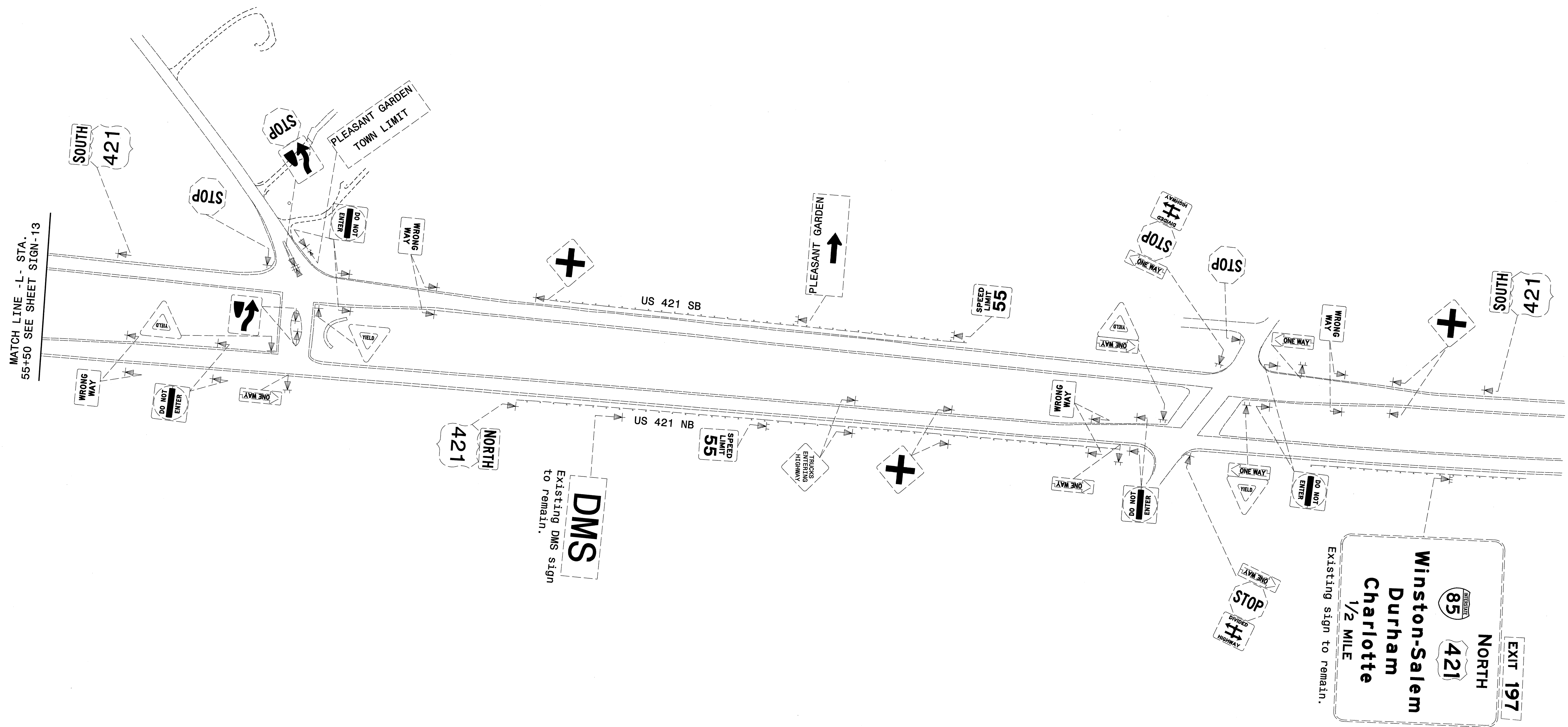

NOTE: REMOVE AND DISPOSE OF EXISTING SIGNS WITHIN PROJECT AREA, UNLESS OTHERWISE NOTED.

Prepared in the offices of:
RAMEY KEMP ASSOCIATES, INC.
 TRANSPORTATION ENGINEERS
 808 Farrington Place, Suite 100
 Raleigh, North Carolina 27609
 919-872-2115 Tel. 919-879-6410 Fax.
 www.rameykemp.com

EXISTING SIGNING DETAIL

TIP NO. R-2612B	SHEET NO. SIGN-15
APPROVED: <i>WJH</i>	
DATE: 2/22/14	
SEAL	
	

NOTE: REMOVE AND DISPOSE OF EXISTING SIGNS WITHIN PROJECT AREA, UNLESS OTHERWISE NOTED.

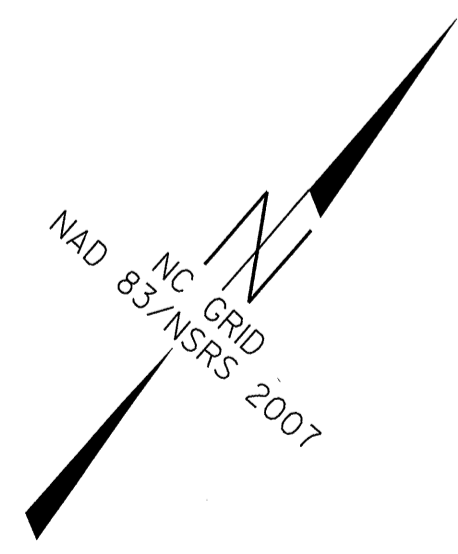
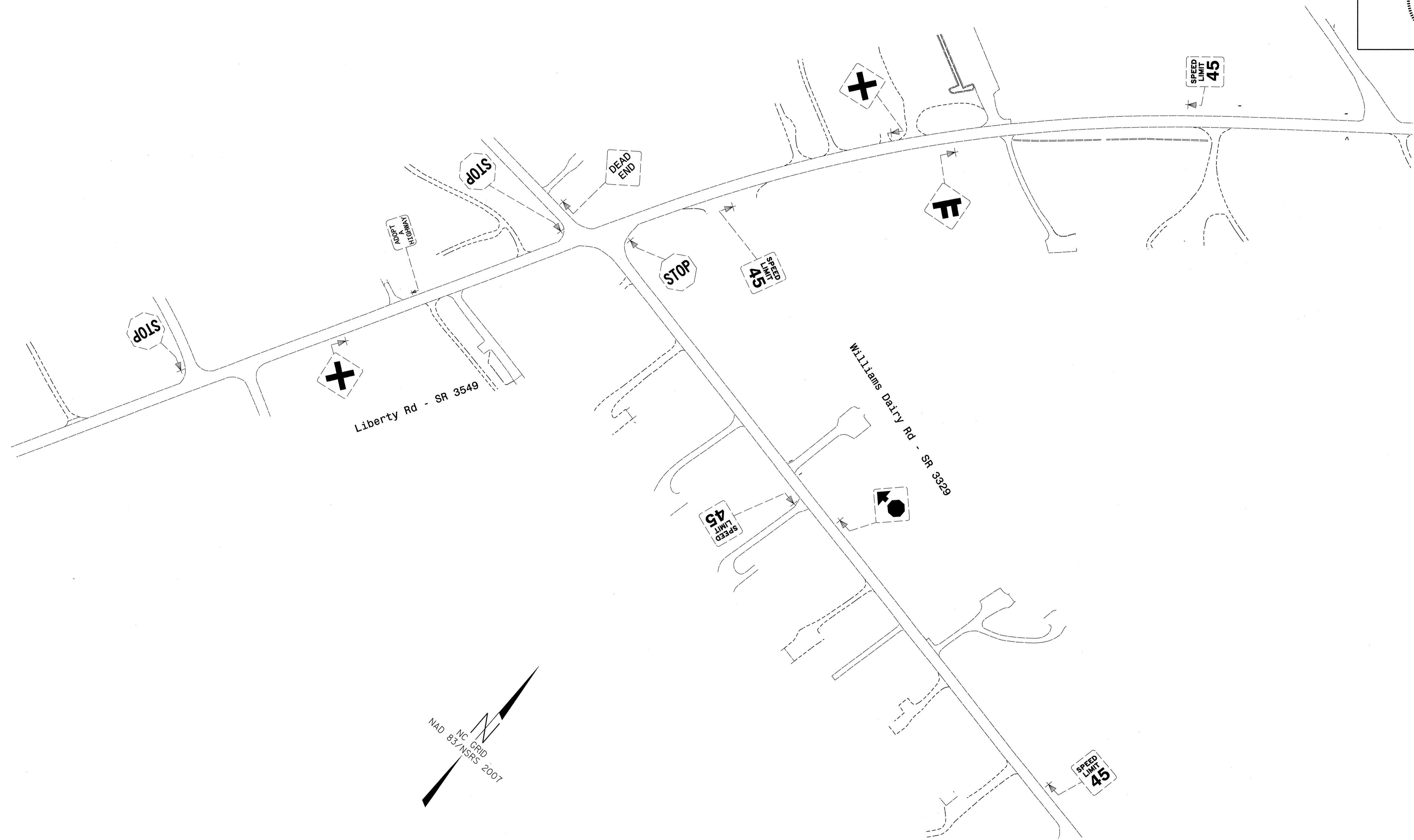

Prepared in the offices of:
RAMEY KEMP & ASSOCIATES, INC.
 TRANSPORTATION ENGINEERS
 6800 Farrington Place, Suite 100
 Raleigh, North Carolina 27609
 919-872-5115 Tel. 919-870-6416 Fax.
 www.rameykemp.com

EXISTING SIGNING DETAIL

TIP NO. R-2612B	SHEET NO. SIGN-16
APPROVED: <i>WJC</i>	
DATE: 3/19/14	
SEAL	
	

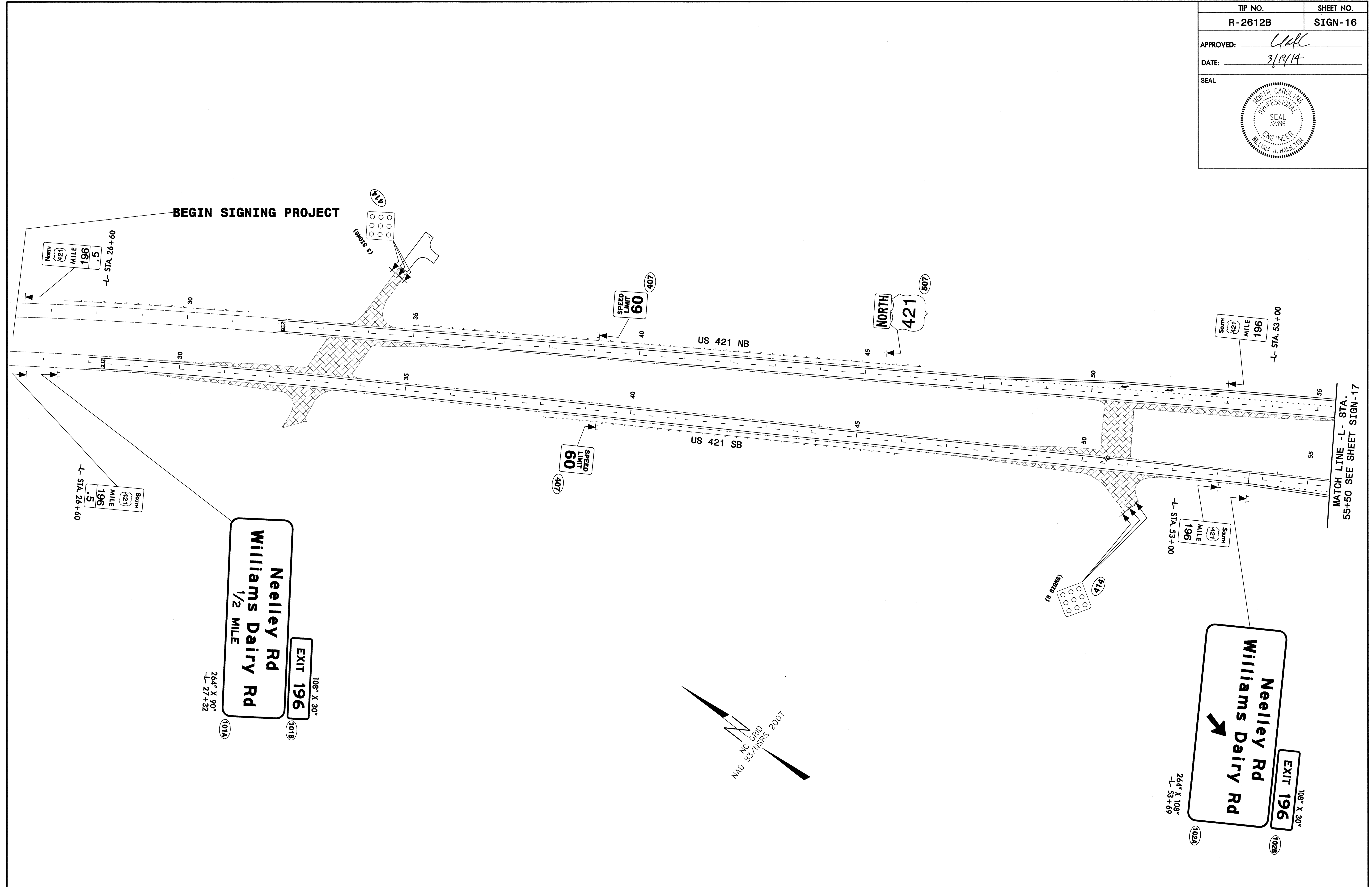

Prepared in the offices of:
RAMEY KEMP ASSOCIATES, INC.
 Transportation Engineers
 8088 Parkington Place, Suite 100
 Raleigh, North Carolina 27609
 919-877-3115 Fax: 919-877-2419 Fax
 www.rameykemp.com

PROPOSED SIGNING DETAIL

TIP NO. R-2612B	SHEET NO. SIGN-17
APPROVED: <i>WJK</i>	
DATE: 3/19/14	
SEAL	

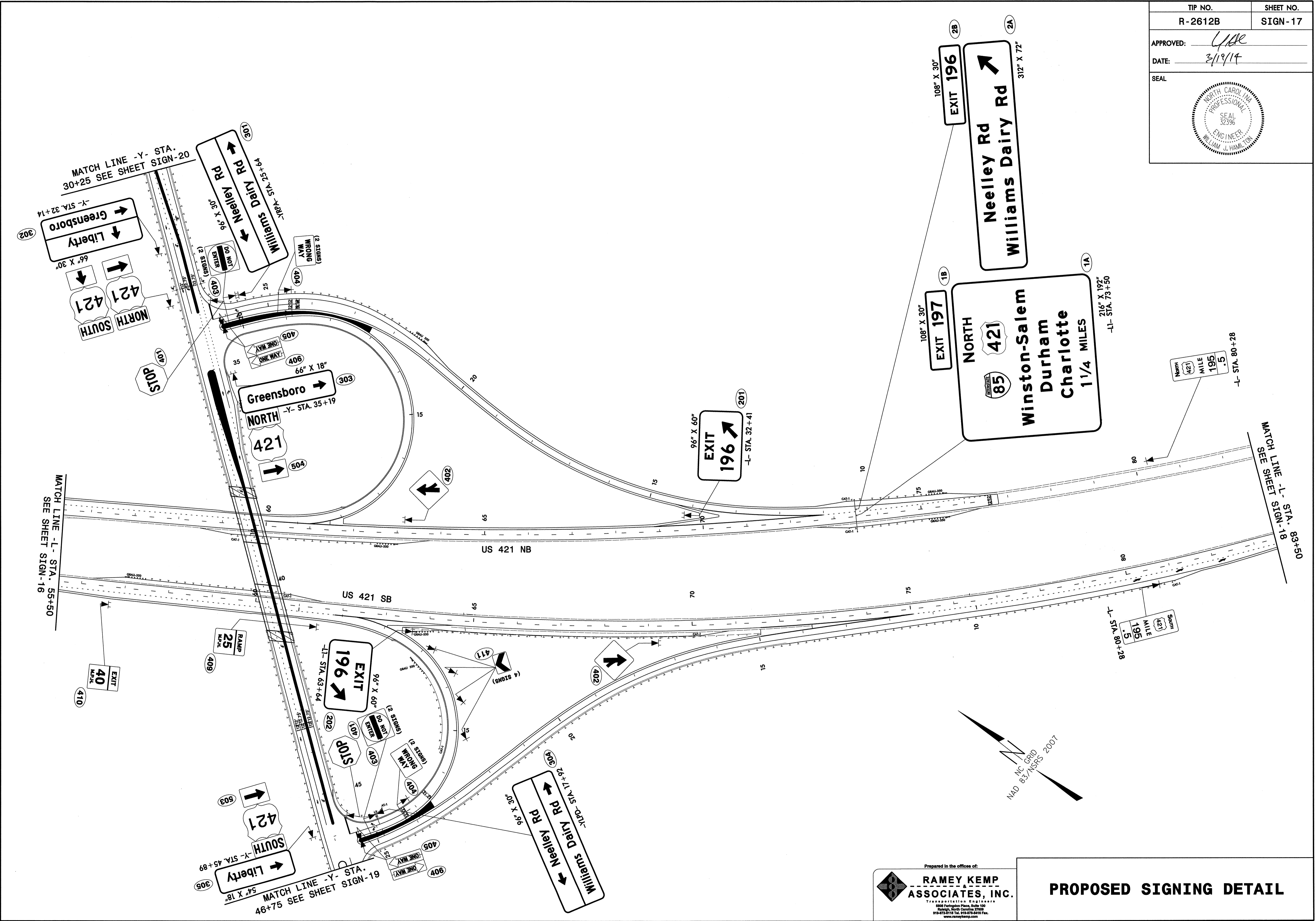

Prepared in the offices of:
RAMEY KEMP ASSOCIATES, INC.
 Transportation Engineers
 8808 Partington Place, Suite 100
 Raleigh, North Carolina 27606
 919-872-9116 Tel. 919-872-6416 Fax.
 www.rameykemp.com

PROPOSED SIGNING DETAIL

TIP NO. R-2612B	SHEET NO. SIGN-18
APPROVED: <i>WJH</i>	
DATE: 3/19/14	
SEAL	

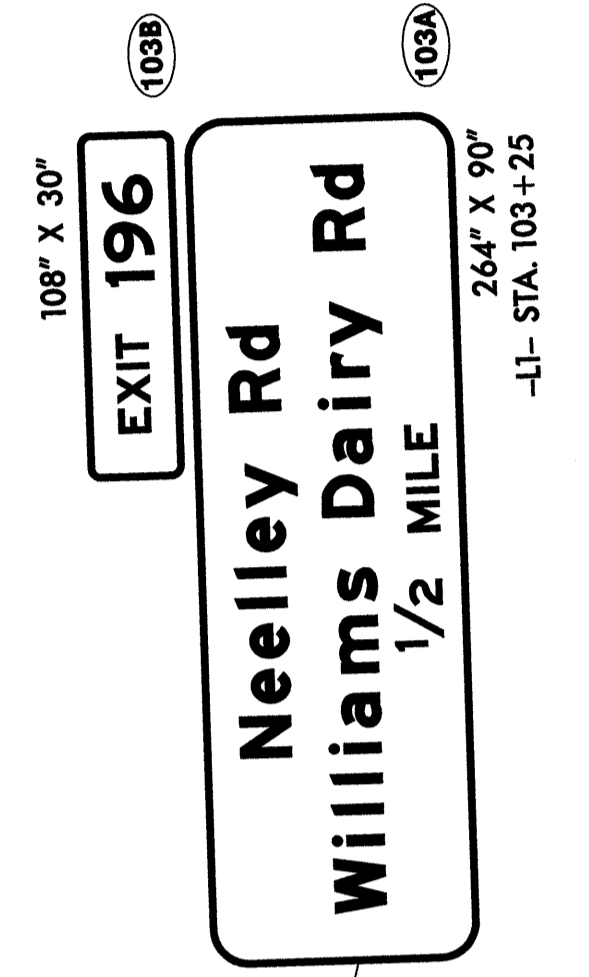
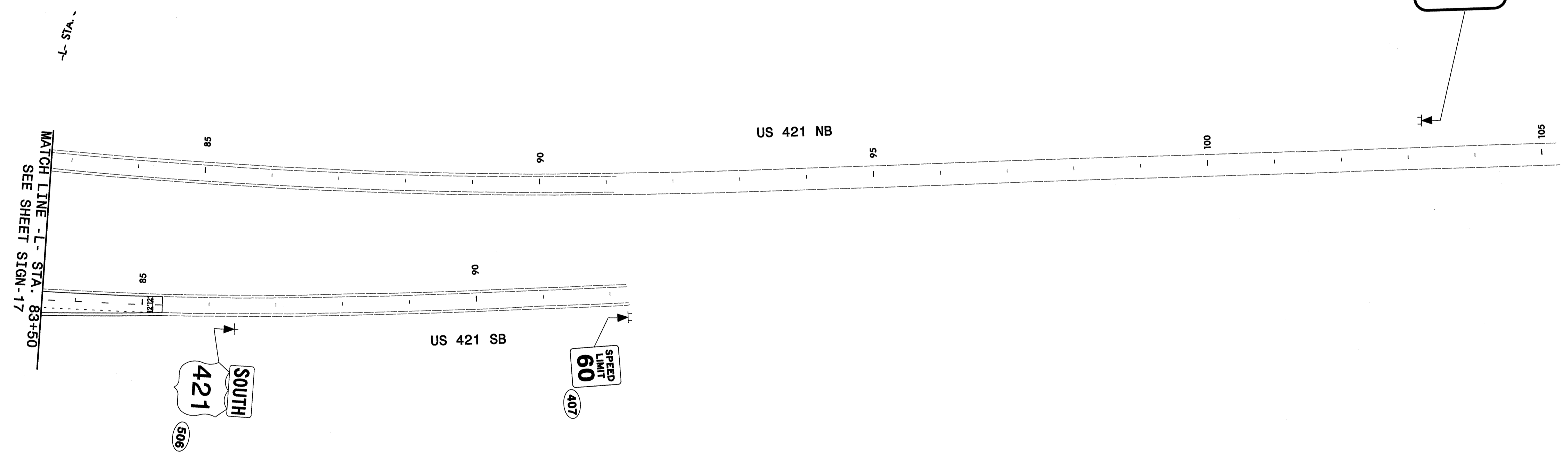
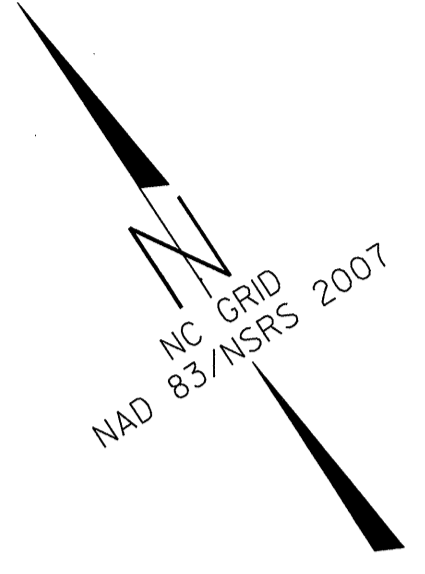

MATCH LINE - L- STA. -
SEE SHEET SIGN-17

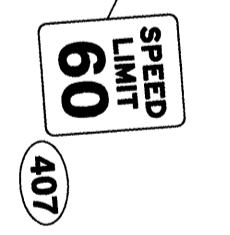
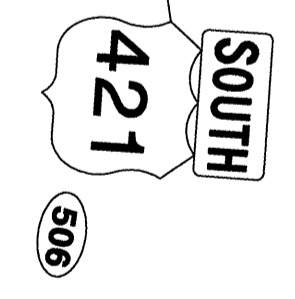

Prepared in the offices of:
RAMEY KEMP ASSOCIATES, INC.
 Transportation Engineers
 6208 Partington Place, Suite 100
 Raleigh, North Carolina 27607
 919-872-2115 Tel. 919-870-8418 Fax.
 www.rameykemp.com

PROPOSED SIGNING DETAIL

TIP NO.	SHEET NO.
R-2612B	SIGN-19
APPROVED: <i>[Signature]</i>	
DATE: 3/19/14	
SEAL	

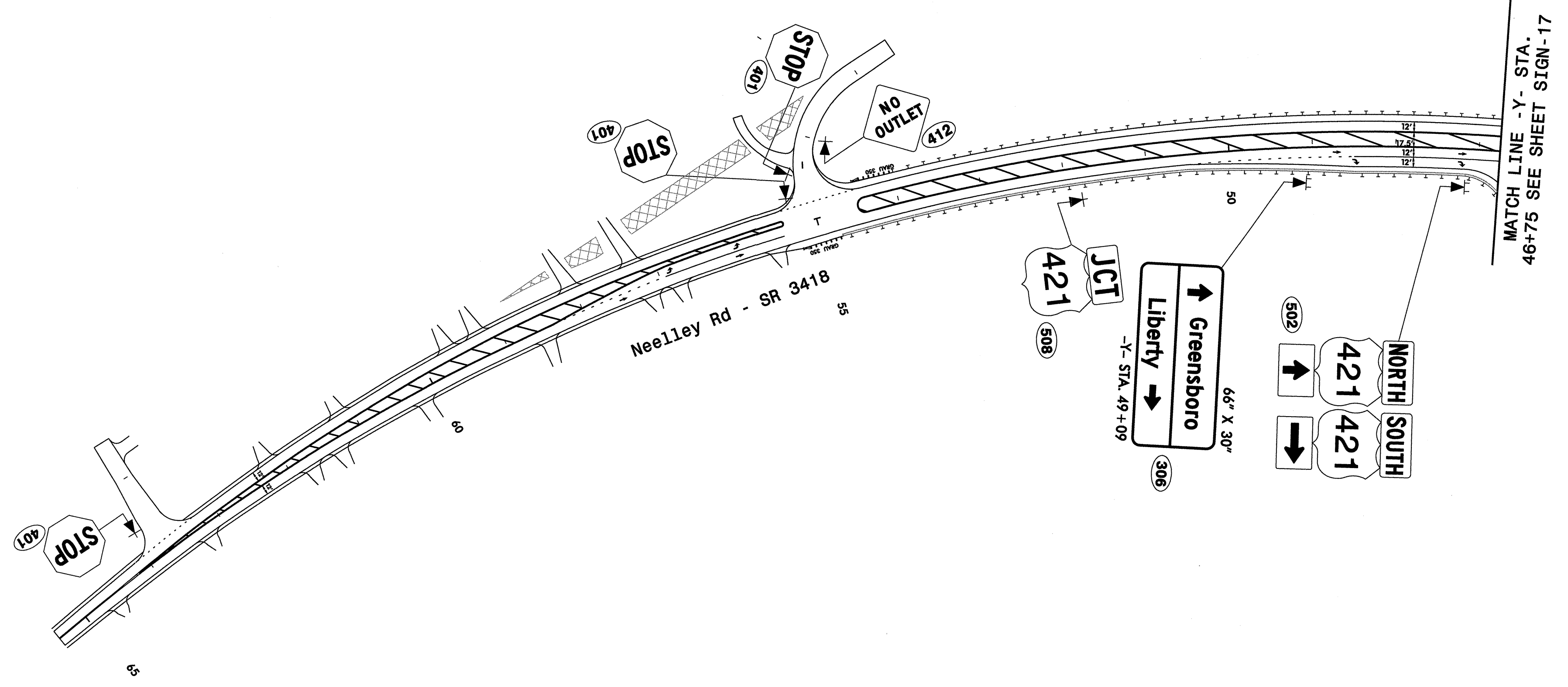
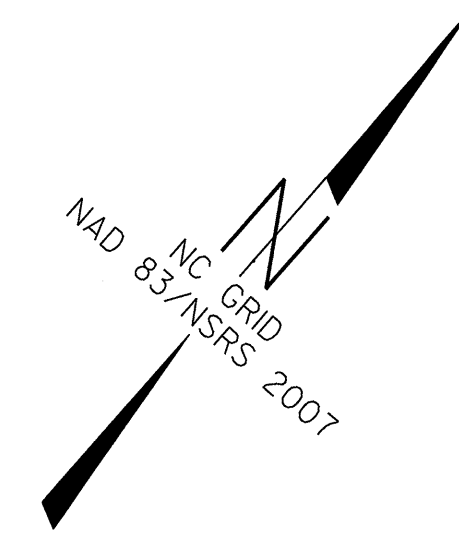

Prepared in the offices of:
RAMEY KEMP & ASSOCIATES, INC.
 Transportation Engineers
 608 Farrington Place, Suite 100
 Raleigh, North Carolina 27609
 919-872-2115 Tel. 919-872-5416 Fax
 www.rameykemp.com

PROPOSED SIGNING DETAIL

TIP NO. R-2612B	SHEET NO. SIGN-20
APPROVED: <i>WJK</i>	
DATE: 3/19/14	
SEAL	
	

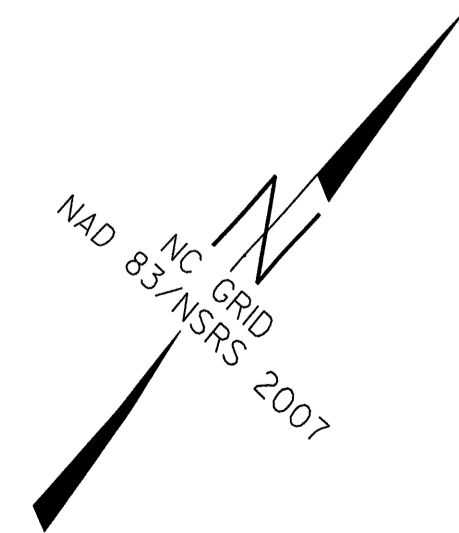
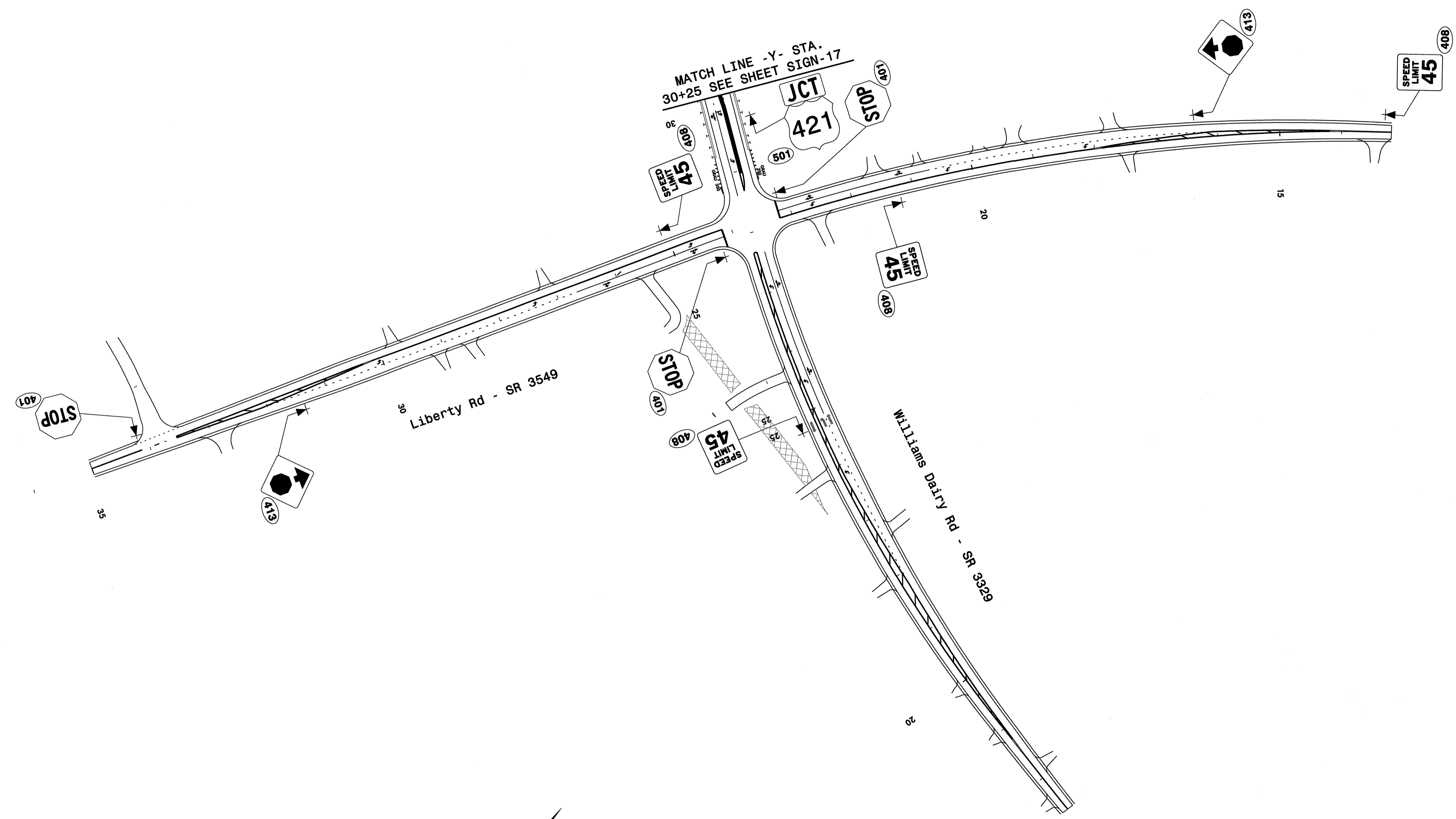

Prepared in the offices of:
RAMEY KEMP & ASSOCIATES, INC.
 Transportation Engineers
 6008 Forthglen Place, Suite 100
 Raleigh, North Carolina 27605
 919-872-6115 Tel. 919-872-6418 Fax
 www.rk-engine.com

PROPOSED SIGNING DETAIL

TIP NO. R-2612B	SHEET NO. SIGN-21
APPROVED: <i>[Signature]</i>	
DATE: 3/19/14	
SEAL	

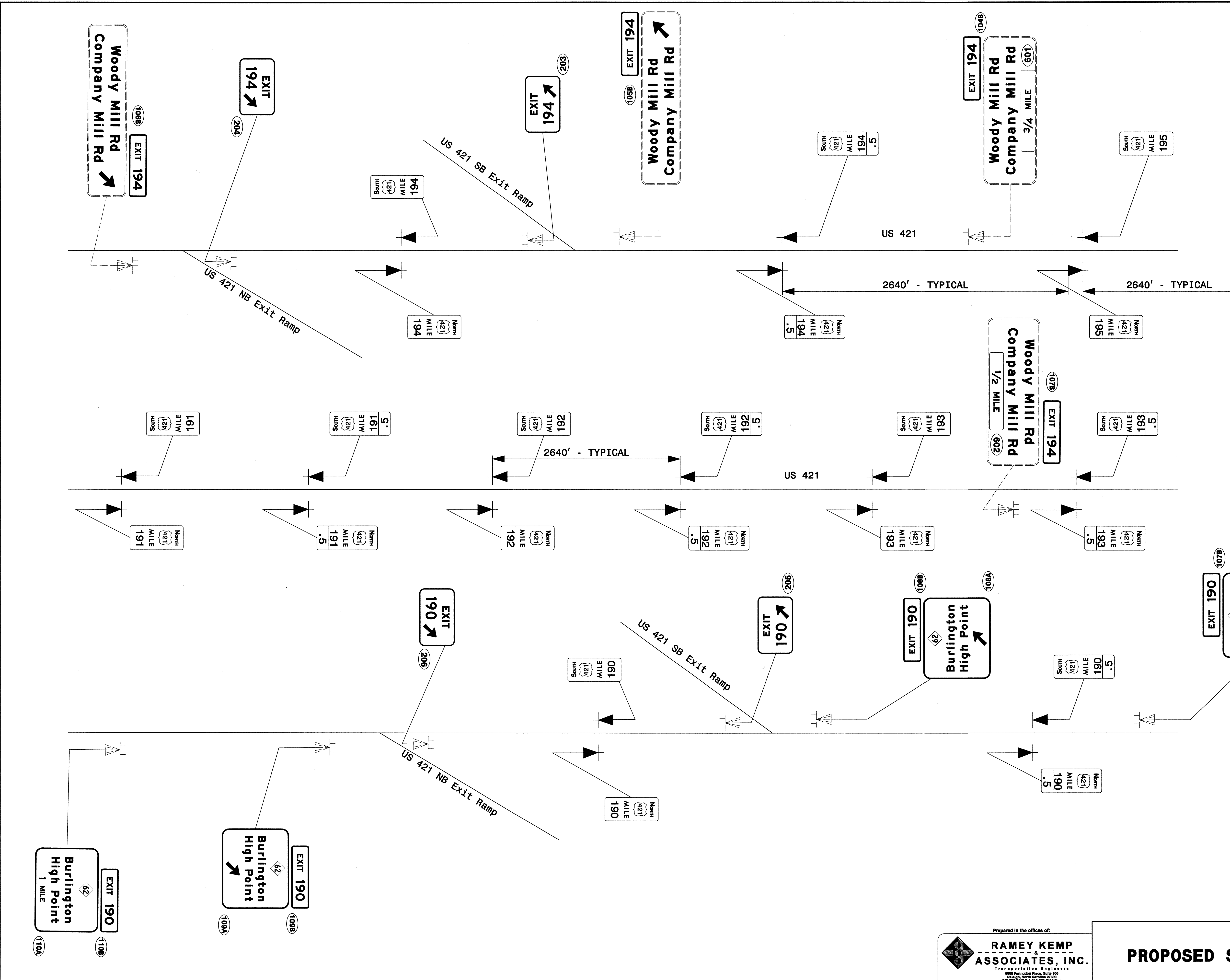

SEE SHEET SIGN-17 FOR MILE MARKER 195.5 LOCATION

NC GRID
NAD 83/NSRS 2007

Prepared in the office of:
RAMEY KEMP ASSOCIATES, INC.
 TRANSPORTATION ENGINEERS
 808 Ferguson Park, Suite 20
 Raleigh, North Carolina 27609
 919-772-1111 or 919-772-5740 Fax
 www.rameykemp.com

PROPOSED SIGNING DETAIL