

T.I.P.: R-3421C

CONTRACT:

**STATE OF NORTH CAROLINA
DEPARTMENT OF TRANSPORTATION**

**SIGNING PLAN
RICHMOND COUNTY**

**LOCATION: US 220 BYPASS FROM 0.2 MILES SOUTHWEST OF
SR 1304 (HARRINGTON RD) TO US 220 BUSINESS/BYPAS
INTERCHANGE SOUTH OF ELLERBE**

TIP NO. R-3421C	SHEET NO. SIGN-1
APPROVED:	
DATE: 8-7-2012	

ROADWAY STANDARD DRAWING

THE FOLLOWING ROADWAY STANDARDS AS APPEAR IN "ROADWAY STANDARD DRAWINGS" - PROJECT SERVICES UNIT - N.C. DEPARTMENT OF TRANSPORTATION - RALEIGH, N.C., DATED JANUARY 2012 ARE APPLICABLE TO THIS PROJECT AND BY REFERENCE HEREBY ARE CONSIDERED A PART OF THESE PLANS:

STD. NO.	TITLE
901.10	TYPE 'A' SIGNS
901.20	TYPE 'B' SIGNS
901.50	ARROWS AND SHIELDS
901.70	SIGN STRINGERS AND SUPPORT SPACING
901.80	SIGN MOUNTING DETAILS - FOR TYPE A AND TYPE B SIGNS
903.10	GROUND MOUNTED SIGN SUPPORTS (EXCEPT 2 OF 3 WHICH IS REPLACED WITH SIGN-2A IN PLANS)
904.10	ORIENTATION OF GROUND MOUNTED SIGNS
904.40	MILEPOST AND PLACEMENT
904.50	MOUNTING OF TYPE 'D', 'E' AND 'F' SIGNS ON 'U' CHANNEL POSTS
1264.01	OBJECT MARKERS
1264.02	PLACEMENT OF OBJECT MARKERS

GENERAL NOTES

- . SIGNS FURNISHED BY STATE
- . **ALL EXISTING SIGNS/SIGN SYSTEMS WITHIN THE PROJECT LIMITS SHALL BE REMOVED AND DISPOSED OF UNLESS OTHERWISE NOTED ON PLANS. THE SIGNS TO BE DISPOSED ARE NOT SHOWN IN PLANS; HOWEVER THE PAY ITEM/QUANTITY IS INCLUDED IN THE CONTRACT.**
- . ALL TYPE 'D' SIGNS SHALL BE MOUNTED ON TWO U-CHANNEL POSTS UNLESS OTHERWISE INDICATED ON THE PLANS.
- . IF REMOVAL OR RELOCATION OF SIGNS ON PRIVATE STREET (NON-STATE MAINTAINED) IS REQUIRED DUE TO CONSTRUCTION, THE CONTRACTOR SHALL INFORM THE ENGINEER. THE WORK WILL BE COMPLETED BY OTHERS.
- . SIGNING PLANS DO NOT INCLUDE TEMPORARY CONSTRUCTION SIGNING, SEE TRAFFIC CONTROL PLANS. SEE PAVEMENT MARKING PLAN FOR PAVEMENT MARKING DESIGN.
- . WHEN NOT STATIONED OR DIMENSIONED ON PLANS, ALL 'E' AND 'F' SIGNS SHALL BE FIELD LOCATED BY THE ENGINEER.
- . WHEN EXISTING SIGNS ARE REMOVED AND INSTALLED ON NEW SUPPORTS, THE RE-ERECTION SHALL IMMEDIATELY FOLLOW THE REMOVAL.
- . THE BACKGROUND FOR TYPE E & F SIGNS SHALL BE GRADE C REFLECTIVE SHEETING.
- . DO NOT BEGIN FABRICATION FOR TYPES A & B SIGNS MOUNTED ON OVERHEAD STRUCTURES OR STEEL SUPPORTS UNTIL "S" DIMENSIONS HAVE BEEN FIELD VERIFIED.
- . SEE ROADWAY PLANS FOR GUARD/GUIDE RAIL DETAILS.

SUMMARY OF QUANTITIES

ITEM NO.		ITEM DESCRIPTION	QUANTITY	UNIT
DESC. NO.	SECT. NO.			
4048000000	902	REINFORCED CONCRETE SIGN FOUNDATION	12	C.Y.
4054000000	902	PLAIN CONCRETE SIGN FOUNDATION	1	C.Y.
4057000000	SP	OVERHEAD FOOTING	84	C.Y.
4060000000	903	SUPPORTS, BREAKAWAY STEEL BEAM	9560	LB.
4072000000	903	SUPPORTS, 3 LB STEEL U-CHANNEL	3304	L.F.
4082100000	SP	SUPPORTS, OVERHEAD SIGN STRUCTURE AT STATION "38+00 -Y9NBL-"	1	L.S.
4082100000	SP	SUPPORTS, OVERHEAD SIGN STRUCTURE AT STATION "11+00 -Y9NBL-"	1	L.S.
4082100000	SP	SUPPORTS, OVERHEAD SIGN STRUCTURE AT STATION "435+00 -L-"	1	L.S.
4082100000	SP	SUPPORTS, OVERHEAD SIGN STRUCTURE AT STATION "425+00 -L-"	1	L.S.
4082100000	SP	SUPPORTS, OVERHEAD SIGN STRUCTURE AT STATION "464+00 -L-"	1	L.S.
4082100000	SP	SUPPORTS, OVERHEAD SIGN STRUCTURE AT STATION "451+25 -L-"	1	L.S.
4082100000	SP	SUPPORTS, OVERHEAD SIGN STRUCTURE AT STATION "476+90 -L-"	1	L.S.
4096000000	904	SIGN ERECTION, TYPE D	7	EA.
4102000000	904	SIGN ERECTION, TYPE E	148	EA.
4108000000	904	SIGN ERECTION, TYPE F	15	EA.
4110000000	904	SIGN ERECTION, TYPE A (GROUND MOUNTED)	7	EA.
4110000000	904	SIGN ERECTION, TYPE B (GROUND MOUNTED)	5	EA.
4114000000	904	SIGN ERECTION, MILEMARKERS	6	EA.
4152000000	907	DISPOSAL OF SIGN SYSTEM, STEEL BEAM	4	EA.
4155000000	907	DISPOSAL OF SIGN SYSTEM, U-CHANNEL	135	EA.

PAY ITEM NOTES

- 1 DISPOSAL OF SIGN SYSTEM, STEEL BEAM
- 2 DISPOSAL OF SIGN SYSTEM, U-CHANNEL
- 3 SIGN ERECTION, TYPE A (GROUND MOUNTED)
- 4 SIGN ERECTION, TYPE B (GROUND MOUNTED)
- 5 SIGN ERECTION, TYPE D, E, AND F
- 6 SIGN ERECTION, MILEMARKERS

INDEX

SHEET NO.	DESCRIPTION
SIGN-1	TITLE SHEET
SIGN-2-2A	SUPPORT INFORMATION AND GROUND MOUNT SHEETS
SIGN-3-3F	OVERHEAD STRUCTURE LINE DRAWINGS
SIGN-4-4H	SIGN DESIGNS, TYPE E & F SIGNS AND MILEMARKERS
SIGN-5-19	SIGN DETAIL SHEETS

PLAN PREPARED BY: N.C.D.O.T. SIGNING AND DELINEATION UNIT

SUSAN KUNZ _____ SIGNING & DELINEATION REGIONAL ENGINEER
SAMUEL COLEMAN, E.I. SIGNING & DELINEATION PROJECT DESIGN ENGINEER

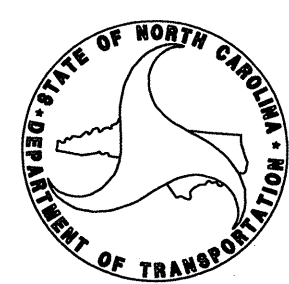

PLAN PREPARED BY :

HNTB HNTB NORTH CAROLINA, P.C.
343 E. Six Forks Road, Suite 200
Raleigh, North Carolina 27609
NC License No: C-1554

C.A. JOHNSON, III, PE SIGNING PROJECT ENGINEER
A.D. KLINKSIEK, E.I. SIGNING DESIGN ENGINEER
T.R. TERRELL SIGNING DESIGN TECHNICIAN

TYPE "A" AND "B" GROUND MOUNTED SIGNS

SIGN NO.	SIGN TYPE	SIGN SIZE (in.)			ROADWAY STATION	NO. OF SUP.	BEAM SECTION	SUPPORT TYPE BA or S	ATTACH METHOD	MOUNTING METHOD	HORIZ CLR. (ft.)	LENGTH (ft)			LEFT SUPPORT (ft)			CENTER SUPPORT (ft)			RIGHT SUPPORT (ft)			FOOTING DIAMETER (ft.)	FOOTING DEPTH (ft.)	B/A SUPPORT WEIGHTS (lbs.)	SIMPLE SUPPORT WEIGHTS (lbs.)	REINF. FTGS. (c.y.)	PLAIN FTGS. (c.y.)	FIELD VERIFIED (mm/dd/yy)																	
		w	x	h								SNS HT H	MTG HT C	EMBED-MENT	S	L	TOTAL LENGTH	S	L	TOTAL LENGTH	S	L	TOTAL LENGTH																								
101A	B	114	X	30	506+20 -L-	2	W8x21	BA	1-R	N/A	30.00	12.50	7.00	5.5	3.00	22.50	28.00	0.00	0.00	0.00	1.00	20.50	26.00	2	6	1319.62	0.00	1.40	0.00																		
*101B	A	126	X	150																																											
102A	B	114	X	30	503+40 -L-LT	3	W10x26	BA	1-R	N/A	18.00	9.00	7.00	6	2.90	18.90	24.90	5.20	21.20	27.20	7.40	23.40	29.40	2.5	6.5	2551.21	0.00	3.55	0.00																		
102B	A	306	X	108																																											
103A	B	114	X	30	532+60 -L-	2	W8x21	BA	1-R	N/A	30.00	12.50	7.00	6	3.70	23.20	29.20	0.00	0.00	0.00	3.90	23.40	29.40	2	6.5	1416.22	0.00	1.51	0.00																		
*103B	A	126	X	150																																											
104A	B	114	X	30	529+80 -L-LT	3	W8x21	BA	1-R	N/A	18.00	9.00	7.00	6	2.10	18.10	24.10	3.60	19.60	25.60	3.00	19.00	25.00	2	6.5	1847.13	0.00	2.27	0.00																		
104B	A	306	X	108																																											
105A	B	114	X	30	555+00 -L-	2	W10x26	BA	1-R	N/A	30.00	14.00	7.00	6	5.00	26.00	32.00	0.00	0.00	0.00	6.80	27.80	33.80	2.5	6.5	1998.94	0.00	2.36	0.00																		
*105B	A	126	X	168																																											
201	A	78	X	60	465+30 -L-	2	S3x5.7	BA	N/A	N/A	△	5.00	7.00	3.5	0.10	12.10	15.60	0.00	0.00	0.00	0.10	12.10	15.60	1	4	213.37	0.00	0.00	0.23																		
202	A	78	X	60	473+25 -L-LT	2	S3x5.7	BA	N/A	N/A	△	5.00	7.00	3.5	0.10	12.10	15.60	0.00	0.00	0.00	0.10	12.10	15.60	1	4	213.37	0.00	0.00	0.23																		
																							TOTAL	9559.88	TOTAL	0.00	TOTAL	11.09	TOTAL	0.47																	
																							USE:	9560	0	12	1																				

*SUPPORT SPACING IS 7.50'.

NOTES

DIMENSION "S" REPRESENTS AN INCREASE (+), OR A DECREASE (-) IN POLE LENGTH, RELATIVE TO THE ELEVATION OF THE EDGE OF PAVEMENT.

FIELD VERIFICATIONS SHALL BE REQUIRED FOR ALL SUPPORTS, SEE (*) ARTICLE 903-3. FABRICATORS SHALL BE AISC CERTIFIED IN CATEGORY 1, SEE (*) ARTICLE 1072-1. (*) = N.C.D.O.T. STANDARD SPECIFICATIONS FOR ROADS AND STRUCTURES

PLAN LOCATIONS FOR EXISTING UTILITIES ARE BASED ON THE BEST AVAILABLE INFORMATION AND, THEREFORE MAY NOT BE PRECISELY ACCURATE. THEREFORE, IT IS INCUMBENT UPON THE CONTRACTOR TO DETERMINE THE EXACT LOCATION OF UTILITIES BEFORE BEGINNING WORK IN A LOCATION.

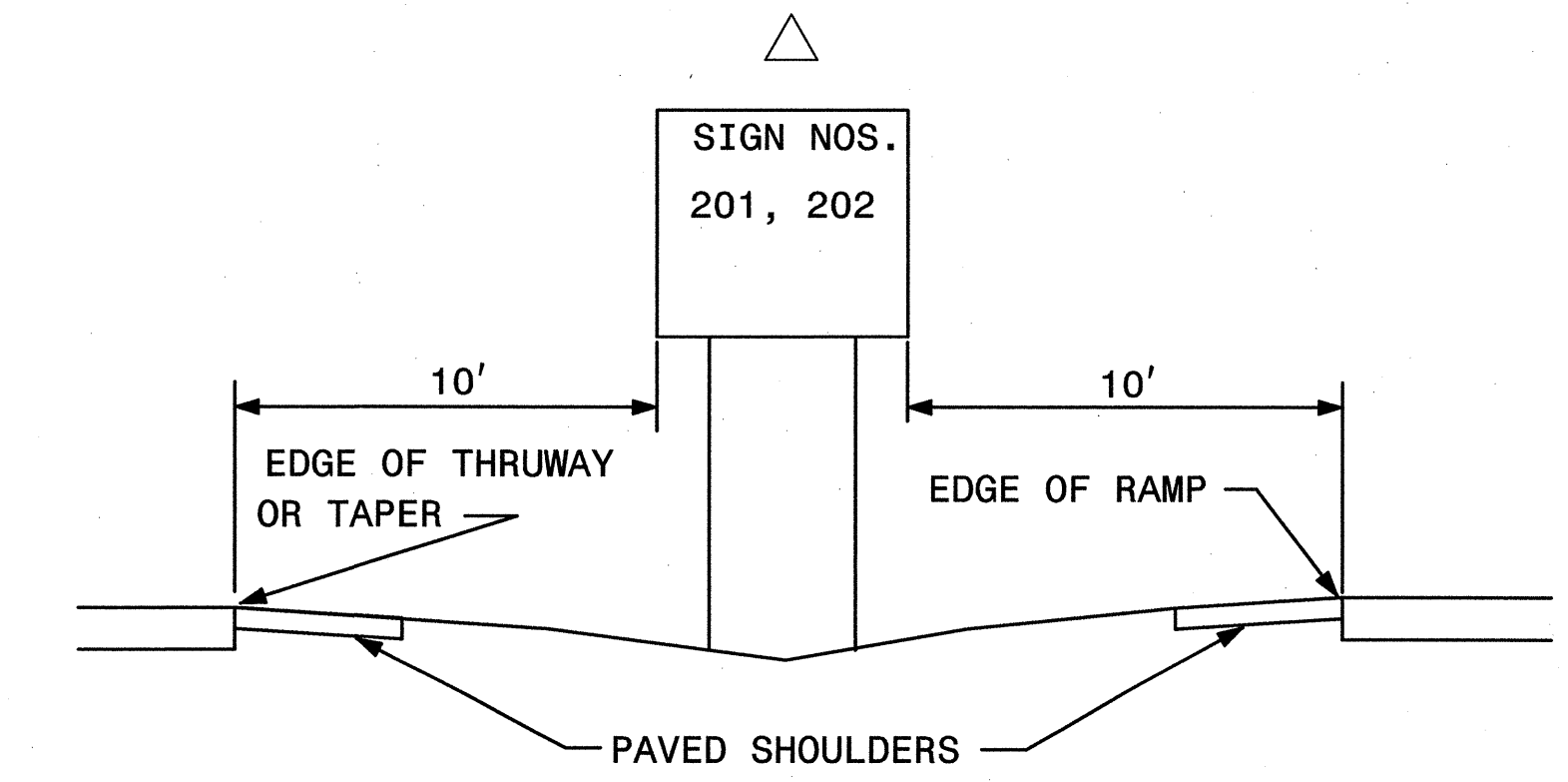
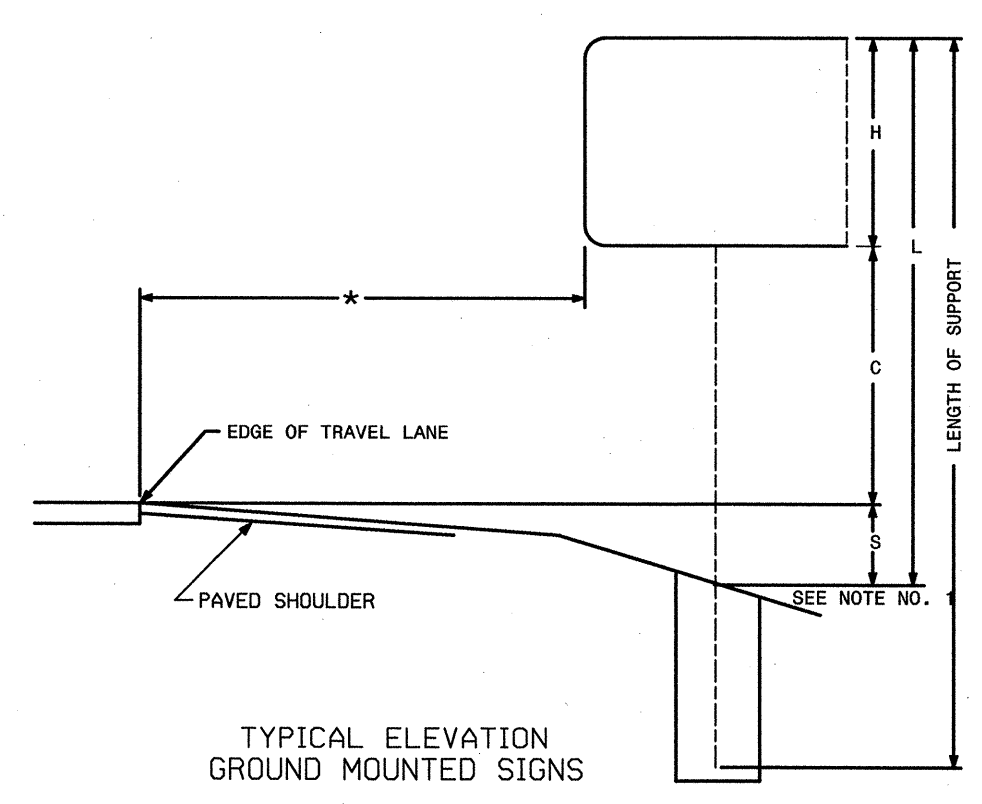

TIP NO. R-3421C	SHEET NO. SIGN-2A
APPROVED: <i>RWF</i>	DATE: 3/8/12
SEAL	
	

STATE OF NORTH CAROLINA
 DEPT. OF TRANSPORTATION
 DIVISION OF HIGHWAYS
 RALEIGH, N.C.

ENGLISH DETAIL DRAWING FOR
GROUND MOUNTED SIGN SUPPORTS

SHEET 2 OF 3
903D10

BEAM SHAPE	BOLT SIZE	SLIP BASE PLATE DATA							KEEPER PLATE DATA							HINGE CONNECTION DATA							BREAK AWAY SUPPORT WEIGHT CONSTANT LBS.			
		A ₁	B ₁	C ₁	D ₁	E ₁	T ₁	R ₁	A ₂	B ₂	C ₂	D ₂	E ₂	R ₂	T ₂	BOLT SIZE	F	G	H	I	J	K		L	R ₃	T ₃
S3X5.7	1/2"DIA. X 3"	7"	4"	1"	3/4"	2 1/2"	1"	9/32"	7"	4"	1"	3/4"	2 1/2"	9/32"	28 GAUGE	1/2"DIA. X 1 1/4"	2 1/4"	3 1/2"	4"	1 1/2"	1"	1 1/2"	2"	9/32"	3/8"	18
S4X7.7	1/2"DIA. X 3"	8"	4"	1"	3/4"	2 1/2"	1"	9/32"	8"	4"	1"	3/4"	2 1/2"	9/32"	28 GAUGE	1/2"DIA. X 1 1/4"	2 5/8"	3 1/2"	4"	1 1/2"	1"	1 1/2"	2"	9/32"	3/8"	20
W6X9	1/2"DIA. X 3"	10"	5"	1"	3/4"	3 1/2"	1"	9/32"	10"	5"	1"	3/4"	3 1/2"	9/32"	28 GAUGE	1/2"DIA. X 1 1/4"	4"	3 1/2"	4"	3/4"	1"	1 1/2"	2"	9/32"	3/8"	32
W6X12	5/8"DIA. X 3 3/4"	11"	5"	1 1/4"	7/8"	3 1/4"	1 1/4"	11/32"	11"	5"	1 1/4"	7/8"	3 1/4"	11/32"	28 GAUGE	5/8"DIA. X 2 1/4"	4"	4"	4 1/2"	3/4"	1 1/8"	5/8"	2 1/4"	11/32"	3/8"	39
W6X16	5/8"DIA. X 3 3/4"	12"	6"	1 1/4"	7/8"	4 1/4"	1 1/2"	11/32"	12"	6"	1 1/4"	7/8"	4 1/4"	11/32"	28 GAUGE	5/8"DIA. X 2 1/4"	4"	4"	4 1/2"	3/4"	1 1/8"	5/8"	2 1/4"	11/32"	1/2"	47
W8X18	5/8"DIA. X 4 1/4"	13 1/2"	6 1/2"	1 1/4"	7/8"	4 3/4"	1 1/2"	11/32"	13 1/2"	6 1/2"	1 1/4"	7/8"	4 3/4"	11/32"	28 GAUGE	5/8"DIA. X 2 1/4"	5 1/4"	4"	4 1/2"	1"	1 1/8"	5/8"	2 1/4"	11/32"	1/2"	70
W8X21	3/4"DIA. X 4 1/4"	14"	7"	1 1/2"	1"	5"	1 1/2"	13/32"	14"	7"	1 1/2"	1"	5"	13/32"	28 GAUGE	3/4"DIA. X 2 3/4"	5 1/4"	6"	7"	1"	1 3/4"	3/4"	3 1/2"	13/32"	1/2"	73
W10X22	3/4"DIA. X 4 1/4"	16"	8"	1 1/2"	1"	6"	1 1/2"	13/32"	16"	8"	1 1/2"	1"	6"	13/32"	28 GAUGE	3/4"DIA. X 2 3/4"	5 3/4"	6"	7"	1"	1 3/4"	3/4"	3 1/2"	13/32"	1/2"	119
W10X26	3/4"DIA. X 4 3/4"	16 1/2"	8"	1 1/2"	1"	6"	1 3/4"	13/32"	16 1/2"	8"	1 1/2"	1"	6"	13/32"	28 GAUGE	3/4"DIA. X 2 3/4"	5 3/4"	6"	7"	1"	1 3/4"	3/4"	3 1/2"	13/32"	5/8"	140
W12X26	3/4"DIA. X 4 3/4"	18 1/2"	9"	1 1/2"	1"	7"	1 3/4"	13/32"	18 1/2"	9"	1 1/2"	1"	7"	13/32"	28 GAUGE	3/4"DIA. X 2 3/4"	6 1/2"	6"	7"	1"	1 3/4"	3/4"	3 1/2"	13/32"	5/8"	176
W14X30	1"DIA. X 5"	22"	9"	2"	1 1/2"	6"	2"	17/32"	22"	9"	2"	1 1/2"	6"	17/32"	28 GAUGE	1"DIA. X 3"	6 3/4"	7"	8"	1 1/4"	2"	1"	4"	17/32"	5/8"	205
W16X31	1"DIA. X 5"	24"	9"	2"	1 1/2"	6"	2"	17/32"	24"	9"	2"	1 1/2"	6"	17/32"	28 GAUGE	1"DIA. X 3 1/4"	5 1/2"	7"	8"	1 1/4"	2"	1"	4"	17/32"	3/4"	223
W18X35	1"DIA. X 5"	25"	9"	2"	1 1/2"	6"	2"	17/32"	25"	9"	2"	1 1/2"	6"	17/32"	28 GAUGE	1"DIA. X 3 1/4"	6"	7"	8"	1 1/4"	2"	1"	4"	17/32"	3/4"	243
W18X40	1"DIA. X 5 1/2"	26"	9"	2"	1 1/2"	6"	2 1/4"	17/32"	26"	9"	2"	1 1/2"	6"	17/32"	28 GAUGE	1"DIA. X 3 3/4"	6"	7"	8"	1 1/4"	2"	1"	4"	17/32"	7/8"	278
W21X44	1"DIA. X 5 1/2"	29"	9"	2"	1 1/2"	6"	2 1/2"	17/32"	29"	9"	2"	1 1/2"	6"	17/32"	28 GAUGE	1"DIA. X 3 3/4"	6 1/2"	7"	8"	1 1/4"	2"	1"	4"	17/32"	7/8"	310

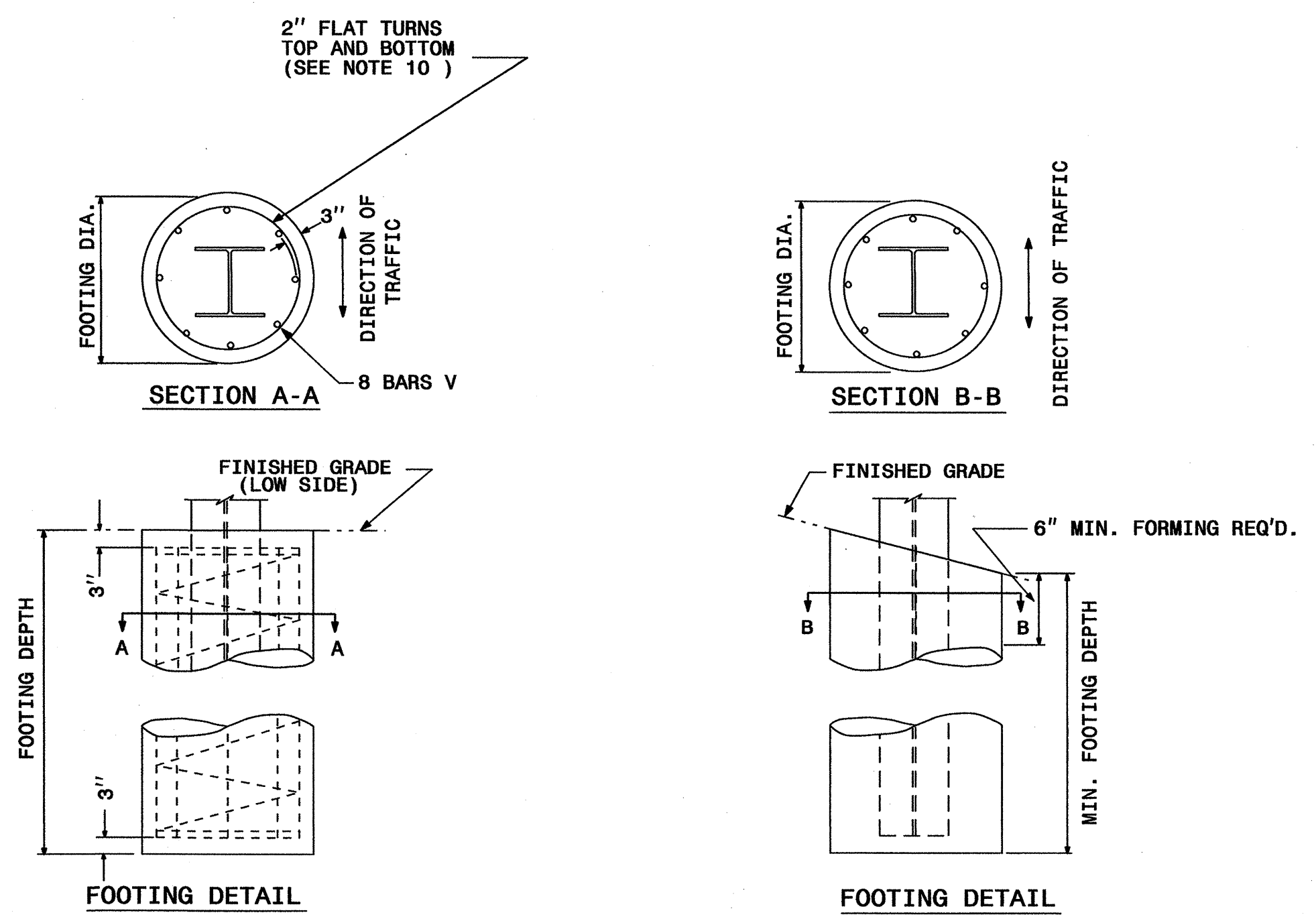

FOUNDATION DATA *		
FOOTING DIAMETER	REINFORCEMENT	SPIRAL BAR
1' 6"	8 # 6 BARS	#3 BAR, 6" PITCH
2'	8 # 7 BARS	#3 BAR, 6" PITCH
2' 6"	8 # 9 BARS	#3 BAR, 6" PITCH
3'	8 # 11 BARS	#3 BAR, 6" PITCH
3' 6"	8 # 12 BARS	#3 BAR, 6" PITCH
4'	8 # 14 BARS	#3 BAR, 6" PITCH

* FOUNDATION DIMENSIONS ARE SHOWN IN PLANS

STATE OF NORTH CAROLINA
 DEPT. OF TRANSPORTATION
 DIVISION OF HIGHWAYS
 RALEIGH, N.C.

ENGLISH DETAIL DRAWING FOR
GROUND MOUNTED SIGN SUPPORTS

SHEET 2 OF 3
903D10

**REVISED SIGNING
 ROADWAY STANDARD DRAWING**

08-MAR-2012 14:00
 S:\S&DU\Standards Group\MP\2012 Standard Drawings\Standard Dwg 8-17-11\Revised\0903D10_sgn_sht102-gm_support_Revise_Scaled.dgn
 AT TE244745

APPROVED: *[Signature]*
 DATE: 8-7-2012

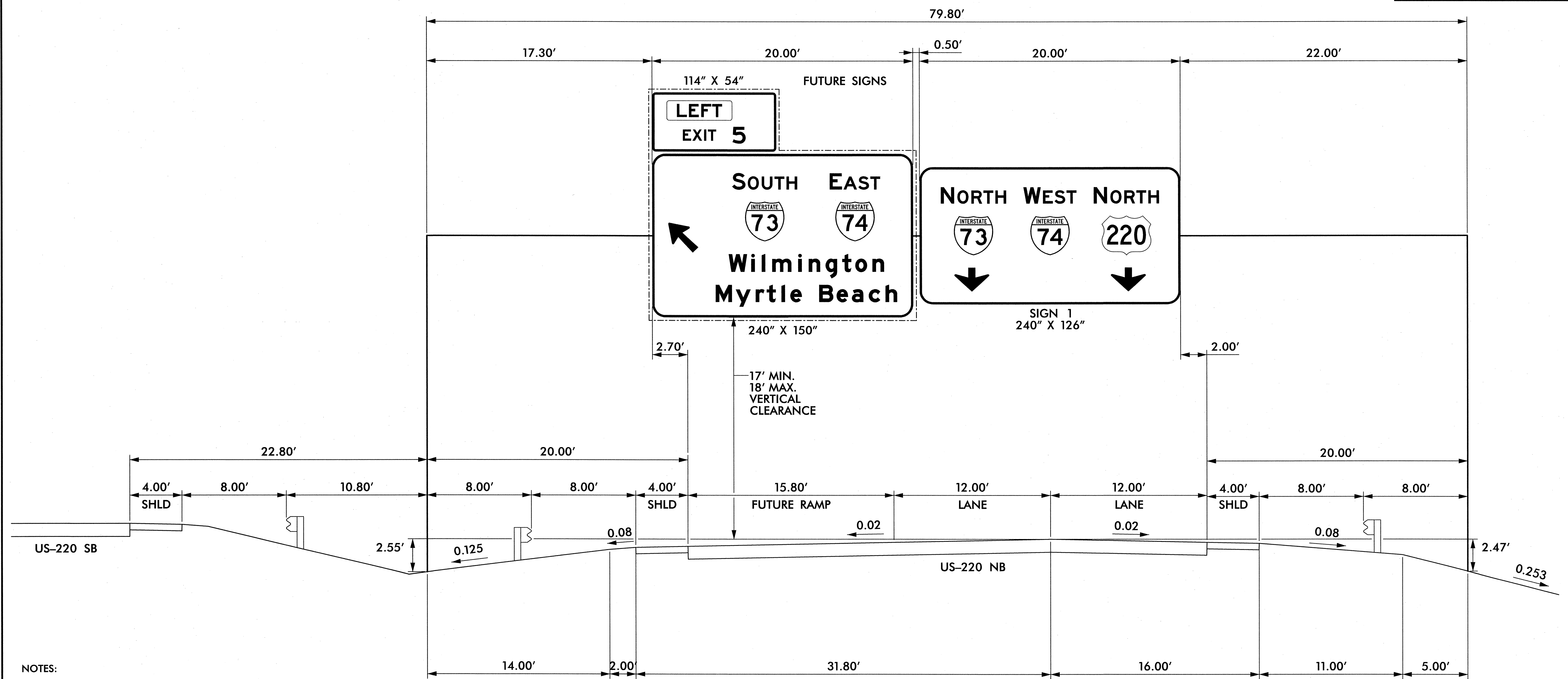
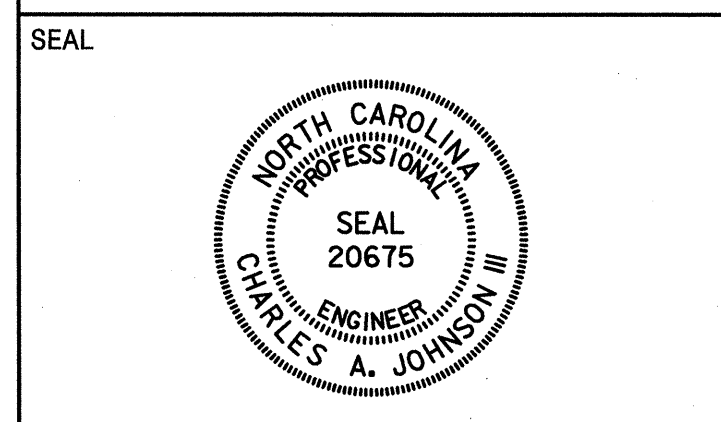

- NOTES:
1. IF THE CONTRACTOR BIDS ALUMINUM SIGN STRUCTURE, EACH SHALL BE PROVIDED WITH AN APPROVED HIGHWAY TRUSS DAMPER DEVICE IN ACCORDANCE WITH AASHTO SPECIFICATIONS.
 2. MOUNT SIGNS VERTICALLY CENTERED ON HORIZONTAL MEMBER OF STRUCTURE.
 3. FIELD VERIFICATION SHALL BE REQUIRED FOR ALL FOOTING ELEVATIONS, PER THE LATEST NCDOT STANDARD SPECIFICATIONS FOR ROADS AND STRUCTURES. PROVIDE FIELD VERIFICATION TO THE SIGNING SECTION.
 4. THE TOP OF THE FOOTING SHALL EXTEND AT LEAST 4 INCHES AND NOT MORE THAN 24 INCHES ABOVE THE HIGHEST POINT OF THE GROUND SURFACE AT THE FOOTING.
 5. SIGN HANGERS AND ATTACHMENT HARDWARE SHALL BE PROVIDED AND INSTALLED ON THE ASSEMBLY TO ACCOMMODATE ALL SIGNS SHOWN IN THIS PLAN SHEET.
 6. DESIGN AND CONSTRUCTION REQUIREMENTS FOR SIGN STRUCTURES SHALL ACCOMMODATE WIND VELOCITY OF 90 M.P.H.

OVERHEAD SIGN ASSEMBLY 'A'
 AT STA. 38+00 -Y9NBL-

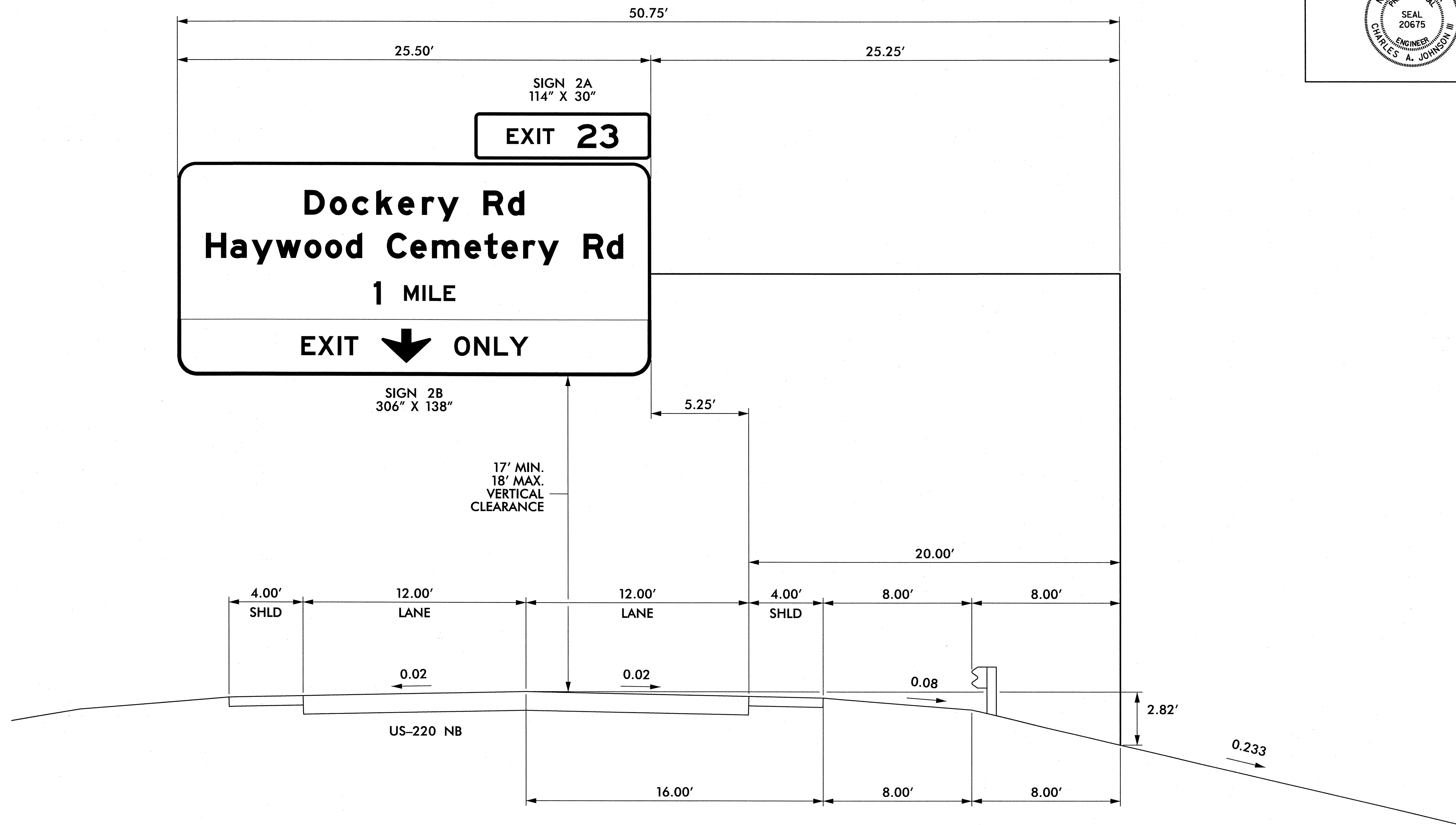

NOTES:

1. IF THE CONTRACTOR BIDS ALUMINUM SIGN STRUCTURE, EACH SHALL BE PROVIDED WITH AN APPROVED HIGHWAY TRUSS DAMPER DEVICE IN ACCORDANCE WITH AASHTO SPECIFICATIONS.
2. MOUNT SIGNS VERTICALLY CENTERED ON HORIZONTAL MEMBER OF STRUCTURE.
3. FIELD VERIFICATION SHALL BE REQUIRED FOR ALL FOOTING ELEVATIONS, PER THE LATEST NCDOT STANDARD SPECIFICATIONS FOR ROADS AND STRUCTURES. PROVIDE FIELD VERIFICATION TO THE SIGNING SECTION.
4. THE TOP OF THE FOOTING SHALL EXTEND AT LEAST 4 INCHES AND NOT MORE THAN 24 INCHES ABOVE THE HIGHEST POINT OF THE GROUND SURFACE AT THE FOOTING.
5. SIGN HANGERS AND ATTACHMENT HARDWARE SHALL BE PROVIDED AND INSTALLED ON THE ASSEMBLY TO ACCOMMODATE ALL SIGNS SHOWN IN THIS PLAN SHEET.
6. DESIGN AND CONSTRUCTION REQUIREMENTS FOR SIGN STRUCTURES SHALL ACCOMMODATE WIND VELOCITY OF 90 M.P.H.

OVERHEAD SIGN ASSEMBLY 'B'
AT STA. 11+00 -Y9NBL-

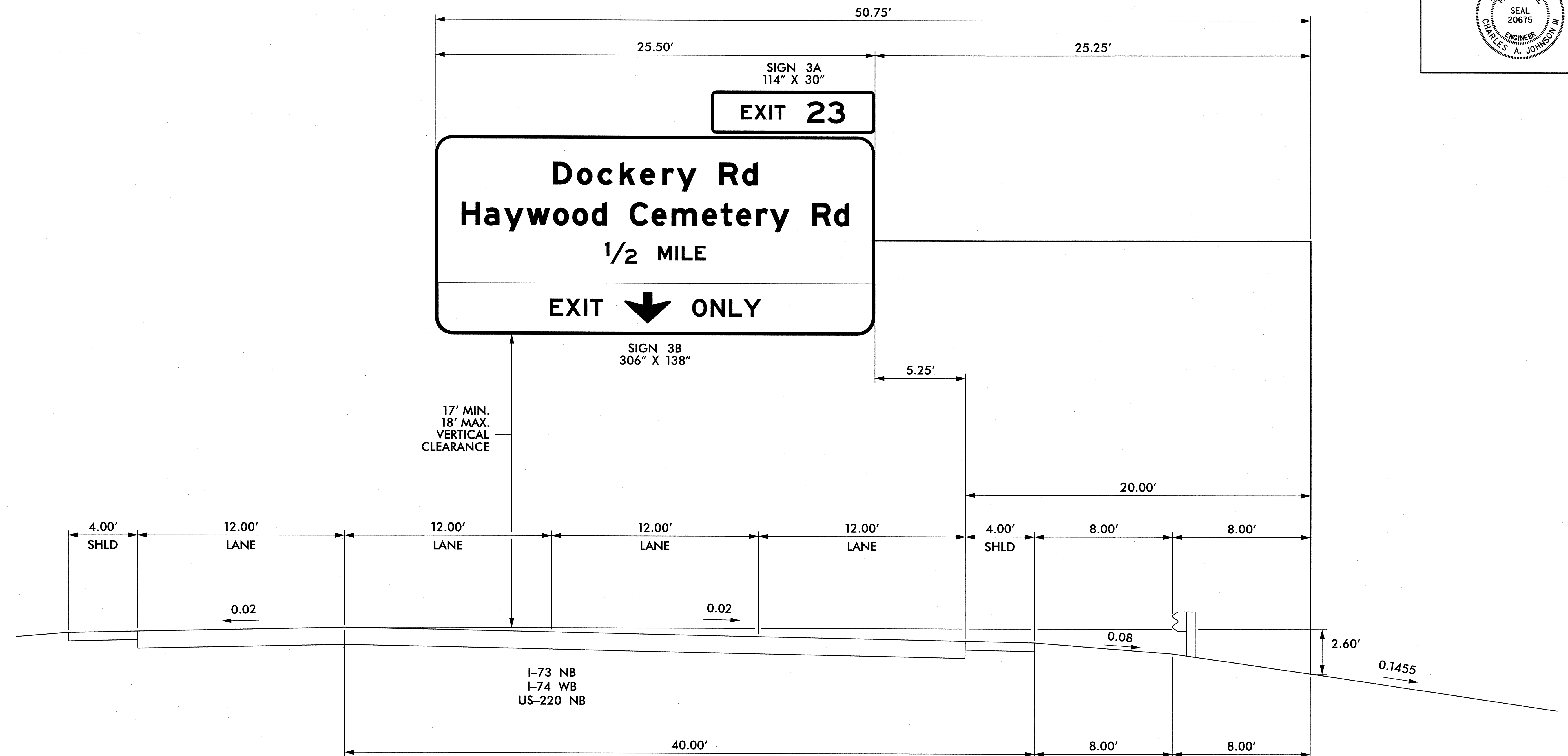
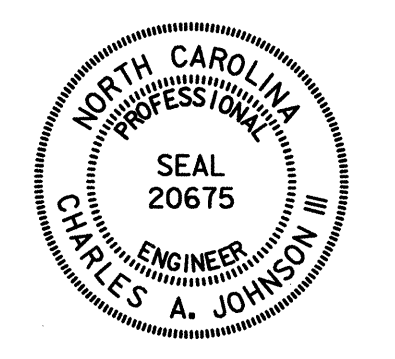

NOTES:

- IF THE CONTRACTOR BIDS ALUMINUM SIGN STRUCTURE, EACH SHALL BE PROVIDED WITH AN APPROVED HIGHWAY TRUSS DAMPER DEVICE IN ACCORDANCE WITH AASHTO SPECIFICATIONS.
- MOUNT SIGNS VERTICALLY CENTERED ON HORIZONTAL MEMBER OF STRUCTURE.
- FIELD VERIFICATION SHALL BE REQUIRED FOR ALL FOOTING ELEVATIONS, PER THE LATEST NCDOT STANDARD SPECIFICATIONS FOR ROADS AND STRUCTURES. PROVIDE FIELD VERIFICATION TO THE SIGNING SECTION.
- THE TOP OF THE FOOTING SHALL EXTEND AT LEAST 4 INCHES AND NOT MORE THAN 24 INCHES ABOVE THE HIGHEST POINT OF THE GROUND SURFACE AT THE FOOTING.
- SIGN HANGERS AND ATTACHMENT HARDWARE SHALL BE PROVIDED AND INSTALLED ON THE ASSEMBLY TO ACCOMMODATE ALL SIGNS SHOWN IN THIS PLAN SHEET.
- DESIGN AND CONSTRUCTION REQUIREMENTS FOR SIGN STRUCTURES SHALL ACCOMMODATE WIND VELOCITY OF 90 M.P.H.

OVERHEAD SIGN ASSEMBLY 'C'
AT STA. 435+00 -L-

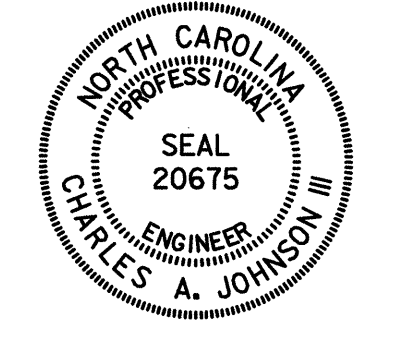
TIP NO. R-3421E	SHEET NO. SIGN-3C
APPROVED: <i>[Signature]</i>	
DATE: 8-7-2012	
SEAL	
	

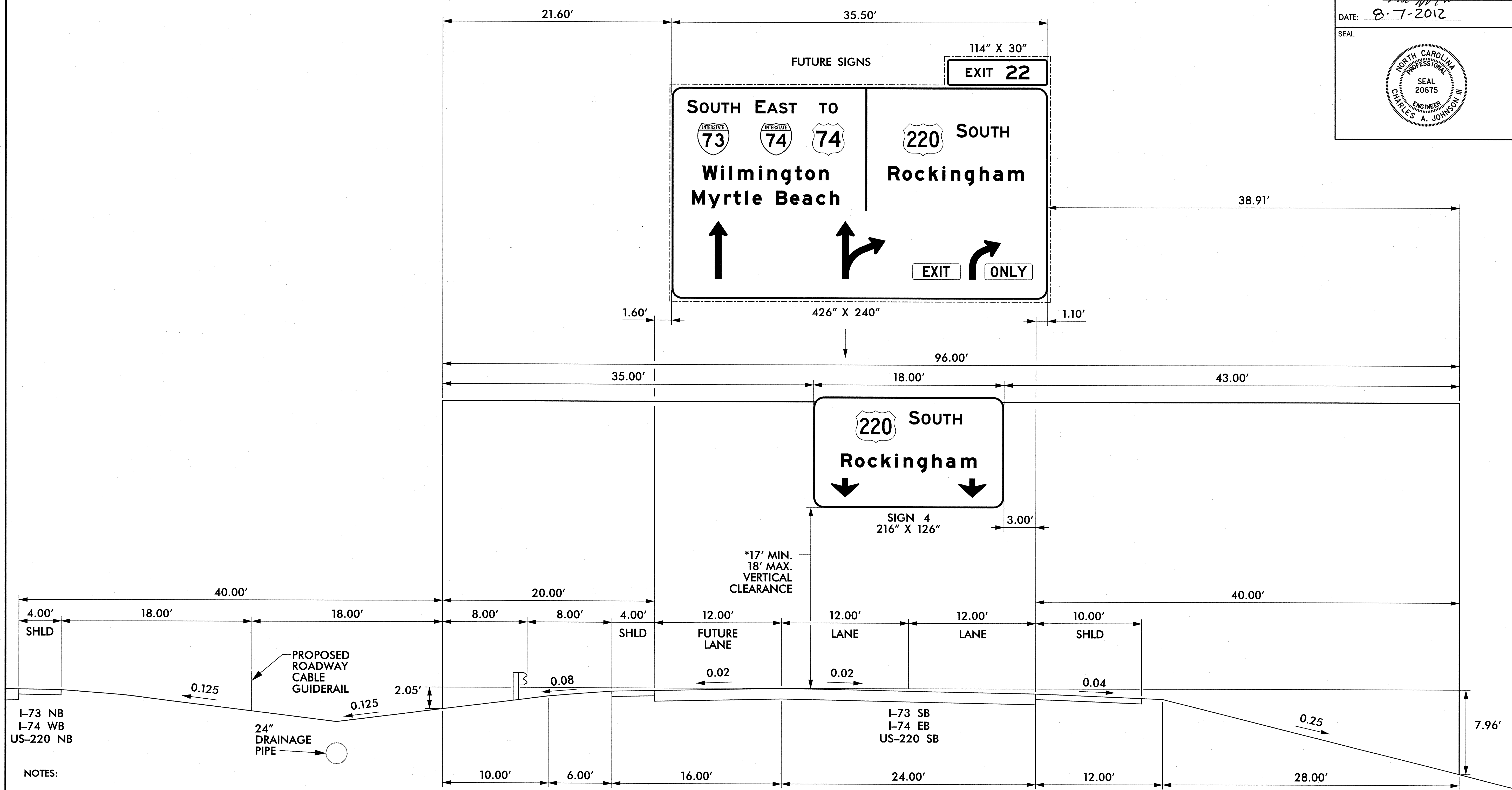

- NOTES:
- IF THE CONTRACTOR BIDS ALUMINUM SIGN STRUCTURE, EACH SHALL BE PROVIDED WITH AN APPROVED HIGHWAY TRUSS DAMPER DEVICE IN ACCORDANCE WITH AASHTO SPECIFICATIONS.
 - MOUNT SIGNS VERTICALLY CENTERED ON HORIZONTAL MEMBER OF STRUCTURE.
 - FIELD VERIFICATION SHALL BE REQUIRED FOR ALL FOOTING ELEVATIONS, PER THE LATEST NCDOT STANDARD SPECIFICATIONS FOR ROADS AND STRUCTURES. PROVIDE FIELD VERIFICATION TO THE SIGNING SECTION.
 - THE TOP OF THE FOOTING SHALL EXTEND AT LEAST 4 INCHES AND NOT MORE THAN 24 INCHES ABOVE THE HIGHEST POINT OF THE GROUND SURFACE AT THE FOOTING.
 - SIGN HANGERS AND ATTACHMENT HARDWARE SHALL BE PROVIDED AND INSTALLED ON THE ASSEMBLY TO ACCOMMODATE ALL SIGNS SHOWN IN THIS PLAN SHEET.
 - DESIGN AND CONSTRUCTION REQUIREMENTS FOR SIGN STRUCTURES SHALL ACCOMMODATE WIND VELOCITY OF 90 M.P.H.

* VERTICAL CLEARANCE TO SIGN 4 AND FUTURE SIGNS SHALL BE 17' MIN. AND 18" MAX.

OVERHEAD SIGN ASSEMBLY 'D'
AT STA. 425+00 -L-

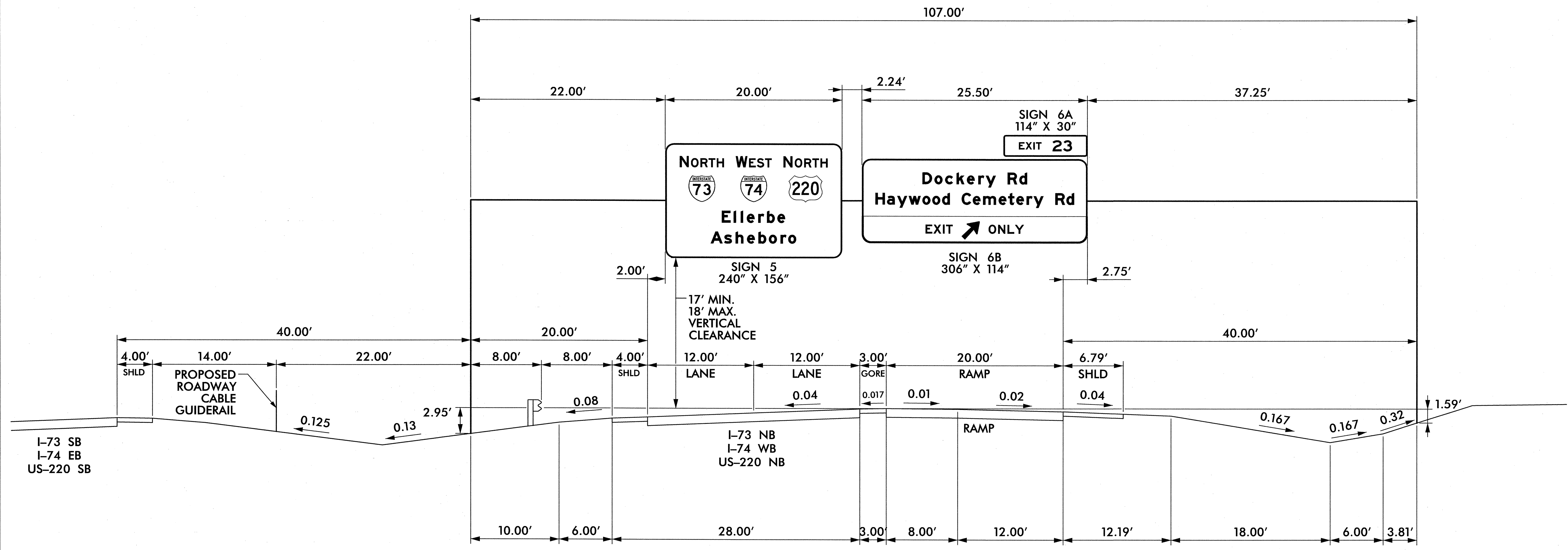

NOTES:

1. IF THE CONTRACTOR BIDS ALUMINUM SIGN STRUCTURE, EACH SHALL BE PROVIDED WITH AN APPROVED HIGHWAY TRUSS DAMPER DEVICE IN ACCORDANCE WITH AASHTO SPECIFICATIONS.
2. MOUNT SIGNS VERTICALLY CENTERED ON HORIZONTAL MEMBER OF STRUCTURE.
3. FIELD VERIFICATION SHALL BE REQUIRED FOR ALL FOOTING ELEVATIONS, PER THE LATEST NCDOT STANDARD SPECIFICATIONS FOR ROADS AND STRUCTURES. PROVIDE FIELD VERIFICATION TO THE SIGNING SECTION.
4. THE TOP OF THE FOOTING SHALL EXTEND AT LEAST 4 INCHES AND NOT MORE THAN 24 INCHES ABOVE THE HIGHEST POINT OF THE GROUND SURFACE AT THE FOOTING.
5. SIGN HANGERS AND ATTACHMENT HARDWARE SHALL BE PROVIDED AND INSTALLED ON THE ASSEMBLY TO ACCOMMODATE ALL SIGNS SHOWN IN THIS PLAN SHEET.
6. DESIGN AND CONSTRUCTION REQUIREMENTS FOR SIGN STRUCTURES SHALL ACCOMMODATE WIND VELOCITY OF 90 M.P.H.

**OVERHEAD SIGN ASSEMBLY "E"
AT STA. 464+00 -L-**

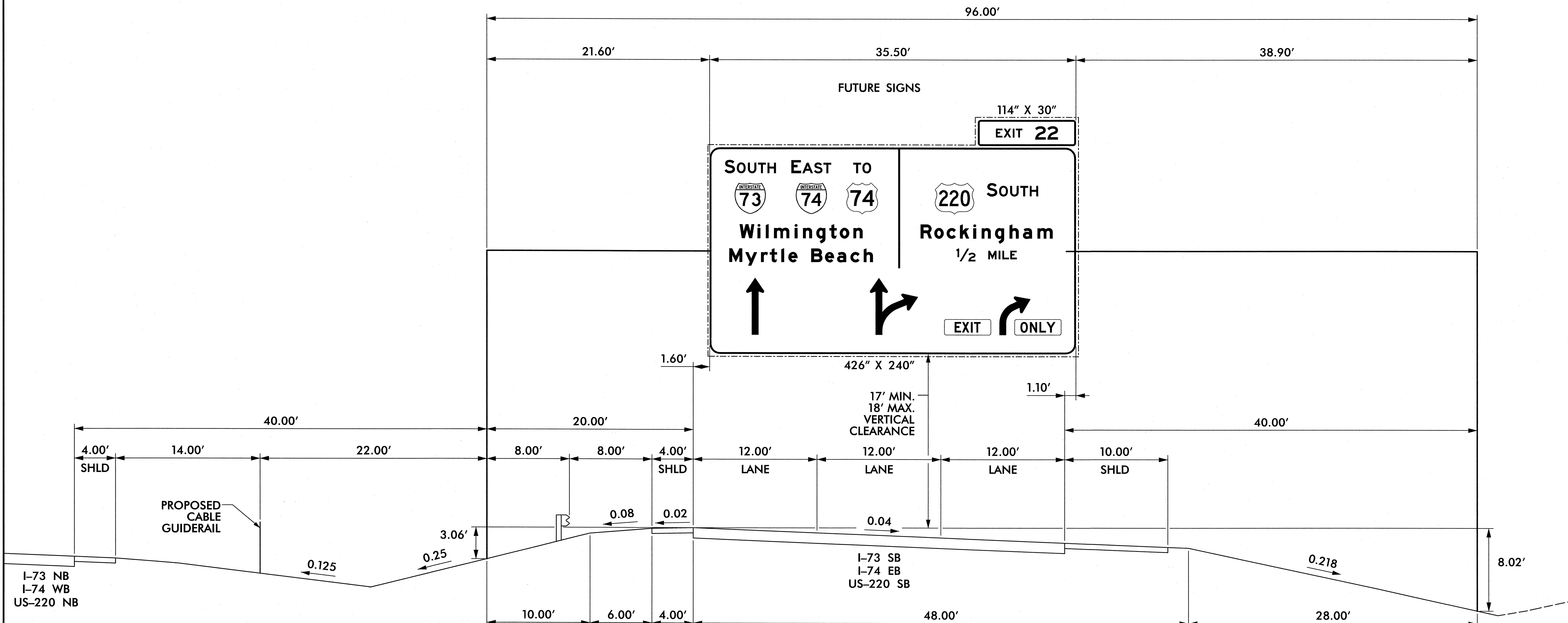

- NOTES:
1. IF THE CONTRACTOR BIDS ALUMINUM SIGN STRUCTURE, EACH SHALL BE PROVIDED WITH AN APPROVED HIGHWAY TRUSS DAMPER DEVICE IN ACCORDANCE WITH AASHTO SPECIFICATIONS.
 2. MOUNT SIGNS VERTICALLY CENTERED ON HORIZONTAL MEMBER OF STRUCTURE.
 3. FIELD VERIFICATION SHALL BE REQUIRED FOR ALL FOOTING ELEVATIONS, PER THE LATEST NCDOT STANDARD SPECIFICATIONS FOR ROADS AND STRUCTURES. PROVIDE FIELD VERIFICATION TO THE SIGNING SECTION.
 4. THE TOP OF THE FOOTING SHALL EXTEND AT LEAST 4 INCHES AND NOT MORE THAN 24 INCHES ABOVE THE HIGHEST POINT OF THE GROUND SURFACE AT THE FOOTING.
 5. SIGN HANGERS AND ATTACHMENT HARDWARE SHALL BE PROVIDED AND INSTALLED ON THE ASSEMBLY TO ACCOMMODATE ALL SIGNS SHOWN IN THIS PLAN SHEET.
 6. DESIGN AND CONSTRUCTION REQUIREMENTS FOR SIGN STRUCTURES SHALL ACCOMMODATE WIND VELOCITY OF 90 M.P.H.

OVERHEAD SIGN ASSEMBLY "F"
AT STA. 451+25 -L-

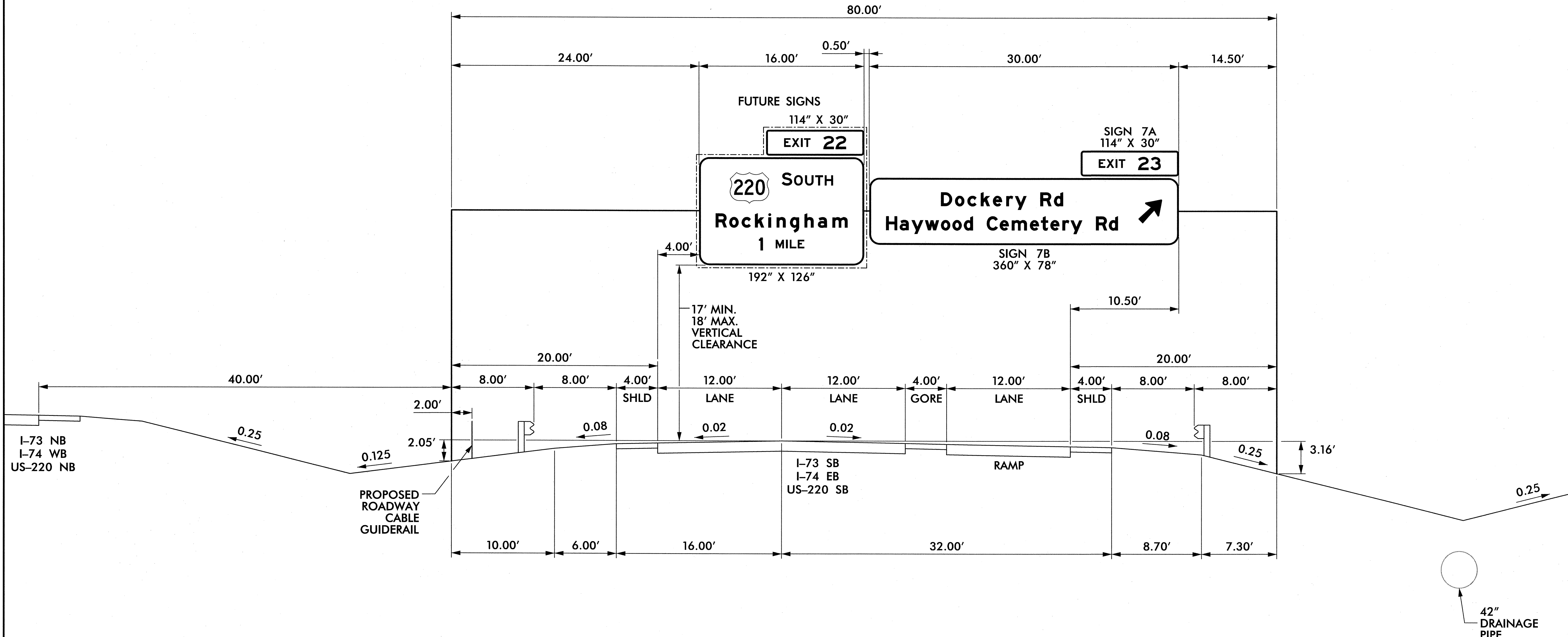

NOTES:

1. IF THE CONTRACTOR BIDS ALUMINUM SIGN STRUCTURE, EACH SHALL BE PROVIDED WITH AN APPROVED HIGHWAY TRUSS DAMPER DEVICE IN ACCORDANCE WITH AASHTO SPECIFICATIONS.
2. MOUNT SIGNS VERTICALLY CENTERED ON HORIZONTAL MEMBER OF STRUCTURE.
3. FIELD VERIFICATION SHALL BE REQUIRED FOR ALL FOOTING ELEVATIONS, PER THE LATEST NCDOT STANDARD SPECIFICATIONS FOR ROADS AND STRUCTURES. PROVIDE FIELD VERIFICATION TO THE SIGNING SECTION.
4. THE TOP OF THE FOOTING SHALL EXTEND AT LEAST 4 INCHES AND NOT MORE THAN 24 INCHES ABOVE THE HIGHEST POINT OF THE GROUND SURFACE AT THE FOOTING.
5. SIGN HANGERS AND ATTACHMENT HARDWARE SHALL BE PROVIDED AND INSTALLED ON THE ASSEMBLY TO ACCOMMODATE ALL SIGNS SHOWN IN THIS PLAN SHEET.
6. DESIGN AND CONSTRUCTION REQUIREMENTS FOR SIGN STRUCTURES SHALL ACCOMMODATE WIND VELOCITY OF 90 M.P.H.

**OVERHEAD SIGN ASSEMBLY 'G'
AT STA. 476+90 -L-**

APPROVED: [Signature] DATE: 8-7-2012

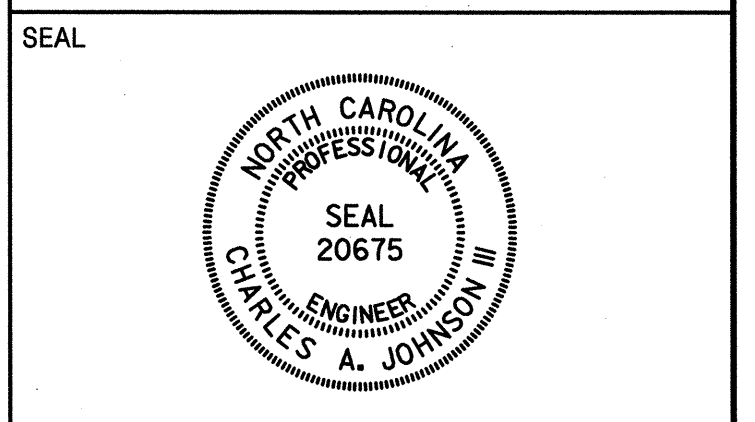

SIGN NUMBER: 1 BACKG COLOR: Green
 TYPE: A (OVHD) COPY COLOR: White
 QUANTITY: 1

SYMBOL	X	Y	WID	HT
M1_1	31.6	45.2	36	36
M1_1	102	45.2	36	36
M1_4	167.8	45.2	45	36
Arrow Down	32	11.9	32	22
Arrow Down	176	11.9	32	22

SIGN WIDTH: 20'-0"
 HEIGHT: 10'-6"
 TOTAL AREA: 210.0 Sq.Ft.
 BORDER TYPE: FLUSH
 RECESS: 0"
 WIDTH: 2"
 RADII: 12"
 NO. Z BARS: 3
 LENGTH: 232.0

DESIGN BY: TRT CHECKED BY: ADK/CAJ
 PROJECT ID: R-3421C DIV: 08 DATE: May 2012

Spacing Factor is 1 unless specified otherwise

LETTER POSITIONS

Letter spacings are to start of next letter

Series/Size	Text Length
E 2000	19.7
E 2000	59.9
E 2000	95.6
E 2000	160.4
E 2000	19.7

SIGN NUMBER: 2A,3A,6A,7A BACKG COLOR: Green
 TYPE: B (OVHD) COPY COLOR: White
 QUANTITY: 4

SYMBOL	X	Y	WID	HT

SIGN WIDTH: 9'-6"
 HEIGHT: 2'-6"
 TOTAL AREA: 23.8 Sq.Ft.
 BORDER TYPE: FLUSH
 RECESS: 0"
 WIDTH: 2"
 RADII: 3.25"
 NO. Z BARS: 2
 LENGTH: 106.0

DESIGN BY: TRT CHECKED BY: ADK/CAJ
 PROJECT ID: R-3421C DIV: 08 DATE: May 2012

Spacing Factor is 1 unless specified otherwise

LETTER POSITIONS

Letter spacings are to start of next letter

Series/Size	Text Length
E 2000	21
E 2000	72

SIGN NUMBER: 2B BACKG COLOR: Green
 TYPE: A (OVHD) COPY COLOR: White
 QUANTITY: 1

SYMBOL	X	Y	WID	HT
AROWDN	131.8	8	32	22

SIGN WIDTH: 25'-6"
 HEIGHT: 11'-6"
 TOTAL AREA: 293.3 Sq.Ft.
 BORDER TYPE: FLUSH
 RECESS: 0"
 WIDTH: 2"
 RADII: 12"
 NO. Z BARS: 3
 LENGTH: 298.0

DESIGN BY: TRT CHECKED BY: ADK/CAJ
 PROJECT ID: R-3421C DIV: 08 DATE: May 2012

Spacing Factor is 1 unless specified otherwise
 Haywood Cemetery Rd spacing factor is 0.7

LETTER POSITIONS

Letter spacings are to start of next letter

Series/Size	Text Length
EM 2000	82.2
EM 2000	141.9
EM 2000	269.6
E 2000	126.9
E 2000	52.6
E 2000	80.1
E 2000	36.7
E 2000	178.9
E 2000	47.9

SIGN NUMBER: 3B BACKG COLOR: Green
 TYPE: A (OVHD) COPY COLOR: White
 QUANTITY: 1

SYMBOL	X	Y	WID	HT
Arrow Down	131.8	8	32	22

SIGN WIDTH: 25'-6"
 HEIGHT: 11'-6"
 TOTAL AREA: 293.3 Sq.Ft.
 BORDER TYPE: FLUSH
 RECESS: 0"
 WIDTH: 2"
 RADII: 12"
 NO. Z BARS: 3
 LENGTH: 298.0

DESIGN BY: TRT CHECKED BY: ADK/CAJ
 PROJECT ID: R-3421C DIV: 08 DATE: May 2012

Spacing Factor is 1 unless specified otherwise
 Haywood Cemetery Rd spacing factor is 0.7

LETTER POSITIONS

Letter spacings are to start of next letter

Series/Size	Text Length
EM 2000	82.2
EM 2000	141.9
EM 2000	269.6
E 2000	118.2
E 2000	70.1
E 2000	80.1
E 2000	36.7
E 2000	178.9
E 2000	47.9

APPROVED: [Signature] DATE: 8-7-2012

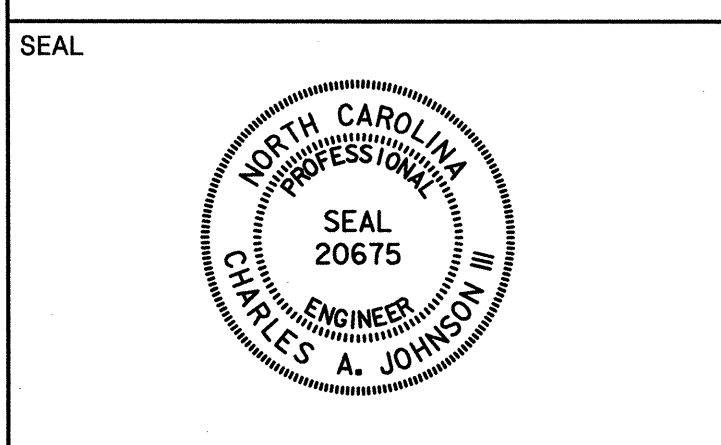

SIGN NUMBER: 4 **BACKG COLOR:** Green **TYPE:** A (OVHD) **COPY COLOR:** White

QUANTITY: 1

SYMBOL	X	Y	WID	HT
M1_4	48.1	74	45	36
ARDOWN	20	12.1	32	22
ARDOWN	164	12.1	32	22

SIGN WIDTH: 18'-0" **HEIGHT:** 10'-6" **TOTAL AREA:** 189.0 Sq.Ft.

BORDER TYPE: FLUSH **RECESS:** 0" **WIDTH:** 2" **RADII:** 12"

MAT'L: 0.125" ALUMINUM

NO. Z BARS: 3 **LENGTH:** 208.0

DESIGN BY: TRT **CHECKED BY:** ADK/CAJ **PROJECT ID:** R-3421C **DIV:** 08 **DATE:** May 2012

Spacing Factor is 1 unless specified otherwise

LETTER POSITIONS

Letter spacings are to start of next letter

Series/Size	Text Length
E 2000	59.8
EM 2000	153.4

SIGN NUMBER: 5 **BACKG COLOR:** Green **TYPE:** A (OVHD) **COPY COLOR:** White

QUANTITY: 1

SYMBOL	X	Y	WID	HT
M1_1	31.6	76.1	36	36
M1_1	102	76.1	36	36
M1_4	167.9	76.1	45	36

SIGN WIDTH: 20'-0" **HEIGHT:** 13'-0" **TOTAL AREA:** 260.0 Sq.Ft.

BORDER TYPE: FLUSH **RECESS:** 0" **WIDTH:** 2" **RADII:** 12"

MAT'L: 0.125" ALUMINUM

NO. Z BARS: 4 **LENGTH:** 232.0

DESIGN BY: TRT **CHECKED BY:** ADK/CAJ **PROJECT ID:** R-3421C **DIV:** 08 **DATE:** May 2012

Spacing Factor is 1 unless specified otherwise

LETTER POSITIONS

Letter spacings are to start of next letter

Series/Size	Text Length
E 2000	59.9
EM 2000	48.8
E 2000	59.9
EM 2000	85.9
EM 2000	116

SIGN NUMBER: 6B **BACKG COLOR:** Green **TYPE:** A (OVHD) **COPY COLOR:** White

QUANTITY: 1

SYMBOL	X	Y	WID	HT
Arrow 45	135	5	20	31.5

SIGN WIDTH: 25'-6" **HEIGHT:** 9'-6" **TOTAL AREA:** 242.3 Sq.Ft.

BORDER TYPE: FLUSH **RECESS:** 0" **WIDTH:** 2" **RADII:** 12"

MAT'L: 0.125" ALUMINUM

NO. Z BARS: 3 **LENGTH:** 298.0

DESIGN BY: TRT **CHECKED BY:** ADK/CAJ **PROJECT ID:** R-3421C **DIV:** 08 **DATE:** May 2012

Spacing Factor is 1 unless specified otherwise
Haywood Cemetery Rd spacing factor is 0.7

LETTER POSITIONS

Letter spacings are to start of next letter

Series/Size	Text Length
EM 2000	141.9
EM 2000	269.6
E 2000	36.7
E 2000	47.9

SIGN NUMBER: 7B **BACKG COLOR:** Green **TYPE:** A (OVHD) **COPY COLOR:** White

QUANTITY: 1

SYMBOL	X	Y	WID	HT
AR_Type A	312.9	25.2	22.3	35.1

SIGN WIDTH: 30'-0" **HEIGHT:** 6'-6" **TOTAL AREA:** 195.0 Sq.Ft.

BORDER TYPE: FLUSH **RECESS:** 0" **WIDTH:** 2" **RADII:** 12"

MAT'L: 0.125" ALUMINUM

NO. Z BARS: 2 **LENGTH:** 352.0

DESIGN BY: TRT **CHECKED BY:** ADK/CAJ **PROJECT ID:** R-3421C **DIV:** 08 **DATE:** May 2012

Spacing Factor is 1 unless specified otherwise
Haywood Cemetery Rd spacing factor is 0.7

LETTER POSITIONS

Letter spacings are to start of next letter

Series/Size	Text Length
EM 2000	141.9
EM 2000	269.6

APPROVED: *[Signature]*
DATE: 8-7-2012

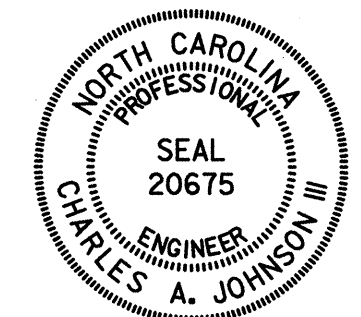

SIGN NUMBER: 101A,103A,105A BACKG COLOR: Green
TYPE: B COPY COLOR: White
QUANTITY: 3

SYMBOL	X	Y	WID	HT

SIGN WIDTH: 9'-6"
HEIGHT: 2'-6"
TOTAL AREA: 23.8 Sq.Ft.

BORDER TYPE: FLUSH
RECESS: 0"
WIDTH: 3.25"
RADI: 2"

NO. Z BARS: 2
LENGTH: 106.0

MAT'L: 0.125" ALUMINUM

DESIGN BY: TRT CHECKED BY: ADK/CAJ
PROJECT ID: R-3421C DIV: 08 DATE: May 2012

NOTES:
1. Legend and border shall be direct applied Grade C reflective sheeting.
2. Background shall be Grade C reflective sheeting.

Spacing Factor is 1 unless specified otherwise

LETTER POSITIONS

Letter spacings are to start of next letter

Series/Size	Text Length
E 2000	72

SIGN NUMBER: 101B BACKG COLOR: Green
TYPE: A COPY COLOR: White
QUANTITY: 1

SYMBOL	X	Y	WID	HT
M1_4	40.5	70.7	45	36

SIGN WIDTH: 10'-6"
HEIGHT: 12'-6"
TOTAL AREA: 131.3 Sq.Ft.

BORDER TYPE: FLUSH
RECESS: 0"
WIDTH: 2"
RADI: 12"

NO. Z BARS: 4
LENGTH: 118.0

MAT'L: 0.125" ALUMINUM

DESIGN BY: TRT CHECKED BY: ADK/CAJ
PROJECT ID: R-3421C DIV: 08 DATE: May 2012

NOTES:
1. Legend and border shall be direct applied Grade C reflective sheeting.
2. Shields shall be Grade C reflective sheeting on 0.032" aluminum and demountable.
3. Background shall be Grade C reflective sheeting.

Spacing Factor is 1 unless specified otherwise

LETTER POSITIONS

Letter spacings are to start of next letter

Series/Size	Text Length
E 2000	86.3
EM 2000	85.9
E 2000	52.6

SIGN NUMBER: 102A,104A BACKG COLOR: Green
TYPE: B COPY COLOR: White
QUANTITY: 2

SYMBOL	X	Y	WID	HT

SIGN WIDTH: 9'-6"
HEIGHT: 2'-6"
TOTAL AREA: 23.8 Sq.Ft.

BORDER TYPE: FLUSH
RECESS: 0"
WIDTH: 3.25"
RADI: 2"

NO. Z BARS: 2
LENGTH: 106.0

MAT'L: 0.125" ALUMINUM

DESIGN BY: TRT CHECKED BY: ADK/CAJ
PROJECT ID: R-3421C DIV: 08 DATE: May 2012

NOTES:
1. Legend and border shall be direct applied Grade C reflective sheeting.
2. Background shall be Grade C reflective sheeting.

Spacing Factor is 1 unless specified otherwise

LETTER POSITIONS

Letter spacings are to start of next letter

Series/Size	Text Length
E 2000	72

SIGN NUMBER: 102B BACKG COLOR: Green
TYPE: A COPY COLOR: White
QUANTITY: 1

SYMBOL	X	Y	WID	HT

SIGN WIDTH: 25'-6"
HEIGHT: 9'-0"
TOTAL AREA: 229.5 Sq.Ft.

BORDER TYPE: FLUSH
RECESS: 0"
WIDTH: 2"
RADI: 12"

NO. Z BARS: 3
LENGTH: 298.0

MAT'L: 0.125" ALUMINUM

DESIGN BY: TRT CHECKED BY: ADK/CAJ
PROJECT ID: R-3421C DIV: 08 DATE: May 2012

NOTES:
1. Legend and border shall be direct applied Grade C reflective sheeting.
2. Background shall be Grade C reflective sheeting.

Spacing Factor is 1 unless specified otherwise
Haywood Cemetery Rd spacing factor is 0.7

LETTER POSITIONS

Letter spacings are to start of next letter

Series/Size	Text Length
EM 2000	141.9
EM 2000	269.6
E 2000	70.1

APPROVED: *[Signature]*
DATE: 8-7-2012

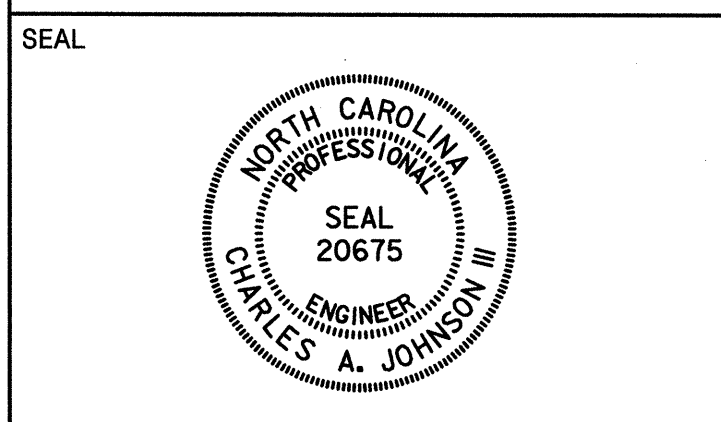

SIGN NUMBER: 1038 BACKG COLOR: Green
TYPE: A COPY COLOR: White

DESIGN BY: TRT CHECKED BY: ADK/CAJ
PROJECT ID: R-3421C DIV: 08 DATE: May 2012

SYMBOL	X	Y	WID	HT
M1_4	40.5	70.7	45	36

QUANTITY: 1

SIGN WIDTH: 10'-6"
HEIGHT: 12'-6"
TOTAL AREA: 131.3 Sq.Ft.

BORDER TYPE: FLUSH
RECESS: 0"
WIDTH: 2"
RADII: 12"

MAT'L: 0.125" ALUMINUM

NO. Z BARS: 4
LENGTH: 118.0

NOTES:
1. Legend and border shall be direct applied Grade C reflective sheeting.
2. Shields shall be Grade C reflective sheeting on 0.032" aluminum and demountable.
3. Background shall be Grade C reflective sheeting.

Spacing Factor is 1 unless specified otherwise

LETTER POSITIONS

Letter spacings are to start of next letter

Series/Size	Text Length
E 2000	86.3
EM 2000	85.9
E 2000	70.1

SIGN NUMBER: 1048 BACKG COLOR: Green
TYPE: A COPY COLOR: White

DESIGN BY: TRT CHECKED BY: ADK/CAJ
PROJECT ID: R-3421C DIV: 08 DATE: May 2012

SYMBOL	X	Y	WID	HT
M1_4	40.5	70.7	45	36

QUANTITY: 1

SIGN WIDTH: 25'-6"
HEIGHT: 9'-0"
TOTAL AREA: 229.5 Sq.Ft.

BORDER TYPE: FLUSH
RECESS: 0"
WIDTH: 2"
RADII: 12"

MAT'L: 0.125" ALUMINUM

NO. Z BARS: 3
LENGTH: 298.0

NOTES:
1. Legend and border shall be direct applied Grade C reflective sheeting.
2. Background shall be Grade C reflective sheeting.

Spacing Factor is 1 unless specified otherwise
Haywood Cemetery Rd spacing factor is 0.7

LETTER POSITIONS

Letter spacings are to start of next letter

Series/Size	Text Length
EM 2000	141.9
EM 2000	269.6
E 2000	52.6

SIGN NUMBER: 1058 BACKG COLOR: Green
TYPE: A COPY COLOR: White

DESIGN BY: TRT CHECKED BY: ADK/CAJ
PROJECT ID: R-3421C DIV: 08 DATE: May 2012

SYMBOL	X	Y	WID	HT
M1_4	40.5	87.9	45	36
ARMED	49.4	20.6	22.3	35

QUANTITY: 1

SIGN WIDTH: 10'-6"
HEIGHT: 14'-0"
TOTAL AREA: 147.0 Sq.Ft.

BORDER TYPE: FLUSH
RECESS: 0"
WIDTH: 2"
RADII: 12"

MAT'L: 0.125" ALUMINUM

NO. Z BARS: 4
LENGTH: 118.0

NOTES:
1. Legend and border shall be direct applied Grade C reflective sheeting.
2. Background shall be Grade C reflective sheeting.

Spacing Factor is 1 unless specified otherwise

LETTER POSITIONS

Letter spacings are to start of next letter

Series/Size	Text Length
E 2000	86.3
EM 2000	85.9

SIGN NUMBER: 201,202 BACKG COLOR: Green
TYPE: A COPY COLOR: White

DESIGN BY: TRT CHECKED BY: ADK/CAJ
PROJECT ID: R-3421C DIV: 08 DATE: May 2012

SYMBOL	X	Y	WID	HT
Type A Arrow	48.5	7.7	18	28.4

QUANTITY: 2

SIGN WIDTH: 6'-6"
HEIGHT: 5'-0"
TOTAL AREA: 32.5 Sq.Ft.

BORDER TYPE: FLUSH
RECESS: 0"
WIDTH: 1.5"
RADII: 6"

MAT'L: 0.125" ALUMINUM

NO. Z BARS: 2
LENGTH: 70.0

NOTES:
1. Legend and border shall be direct applied Grade C reflective sheeting.
2. Background shall be Grade C reflective sheeting.

Spacing Factor is 1 unless specified otherwise

LETTER POSITIONS

Letter spacings are to start of next letter

Series/Size	Text Length
EM 2000	37
E 2000	31.7

APPROVED: *[Signature]*
DATE: 8-7-2012

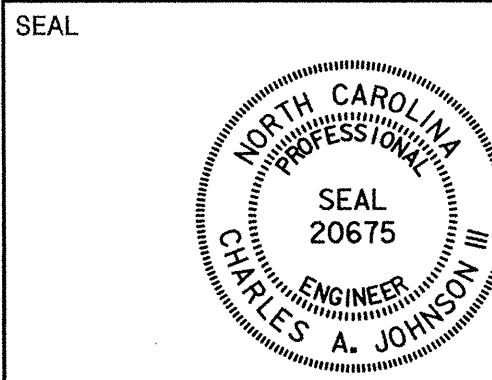

SIGN NUMBER: 301 BACKG COLOR: Green
TYPE: D COPY COLOR: White
QUANTITY: 1

SYMBOL	X	Y	WID	HT
Arrow Left	8.9	6.4	6	9

SIGN WIDTH: 5'-6"
HEIGHT: 1'-6"
TOTAL AREA: 8.3 Sq.Ft.

BORDER TYPE: FLUSH
RECESS: 0"
WIDTH: 0.75"
RADIUS: 2.25"

MAT'L: 0.125" ALUMINUM

DESIGN BY: TRT CHECKED BY: ADK/CAJ
PROJECT ID: R-3421C DIV: 08 DATE: May 2012

BORDER
R=2.25"
TH=0.75"

Spacing Factor is 1 unless specified otherwise

LETTER POSITIONS

Letter spacings are to start of next letter											Series/Size
											Text Length
	A	s	h	e	b	o	r	o			D 2000
	23.9	5.5	3.6	4.4	4.4	4.3	4.6	2.8	3.7	8.8	33.3

SIGN NUMBER: 302,304 BACKG COLOR: Green / Green
TYPE: D COPY COLOR: White
QUANTITY: 2

SYMBOL	X	Y	WID	HT
Arrow Left	7.2	25.7	6	9
Arrow Right	59.4	5.1	6	9

SIGN WIDTH: 6'-6"
HEIGHT: 3'-6"
TOTAL AREA: 22.8 Sq.Ft.

BORDER TYPE: FLUSH
RECESS: 0"
WIDTH: 0.75"
RADIUS: 2.25"

MAT'L: 0.125" ALUMINUM

DESIGN BY: TRT CHECKED BY: ADK/CAJ
PROJECT ID: R-3421C DIV: 08 DATE: May 2012

BORDER
R=2.25"
TH=0.75"

Spacing Factor is 1 unless specified otherwise

LETTER POSITIONS

Letter spacings are to start of next letter											Series/Size			
											Text Length			
	H	a	y	w	o	o	d				D 2000			
	29.7	5.1	4.1	4.7	7.3	4.4	4.4	3.6	14.7		33.5			
	C	e	m	e	t	e	r	y		R d	D 2000			
	22.2	5	4.4	6.8	3.8	2.8	4.4	2.5	4.5	6	4.7	3.6	7.2	48.7
	D	o	c	k	e	r	y			R d				D 2000
	9.6	5	4.4	4.3	4.3	4.4	2.5	4.5	6	4.7	3.6	24.6		43.8

SIGN NUMBER: 303 BACKG COLOR: Green
TYPE: D COPY COLOR: White
QUANTITY: 1

SYMBOL	X	Y	WID	HT
Arrow Right	56.6	6	6	9

SIGN WIDTH: 6'-0"
HEIGHT: 1'-6"
TOTAL AREA: 9.0 Sq.Ft.

BORDER TYPE: FLUSH
RECESS: 0"
WIDTH: 0.75"
RADIUS: 2.25"

MAT'L: 0.125" ALUMINUM

DESIGN BY: TRT CHECKED BY: ADK/CAJ
PROJECT ID: R-3421C DIV: 08 DATE: May 2012

BORDER
R=2.25"
TH=0.75"

Spacing Factor is 1 unless specified otherwise

LETTER POSITIONS

Letter spacings are to start of next letter											Series/Size		
											Text Length		
	R	o	c	k	i	n	g	h	a	m	D 2000		
	6.4	4.7	4.4	4.3	4.6	2.2	4.4	4.8	4.4	4.6	5.9	21.4	44.3

SIGN NUMBER: 305 BACKG COLOR: Green / Green
TYPE: D COPY COLOR: White
QUANTITY: 1

SYMBOL	X	Y	WID	HT
Arrow Straight	13.3	17.8	6	9
Arrow Left	6.4	4.7	6	9

SIGN WIDTH: 6'-0"
HEIGHT: 2'-6"
TOTAL AREA: 15.0 Sq.Ft.

BORDER TYPE: FLUSH
RECESS: 0"
WIDTH: 0.75"
RADIUS: 2.25"

MAT'L: 0.125" ALUMINUM

DESIGN BY: TRT CHECKED BY: ADK/CAJ
PROJECT ID: R-3421C DIV: 08 DATE: May 2012

BORDER
R=2.25"
TH=0.75"

Spacing Factor is 1 unless specified otherwise

LETTER POSITIONS

Letter spacings are to start of next letter											Series/Size		
											Text Length		
	A	s	h	e	b	o	r	o			D 2000		
	25.4	5.5	3.6	4.4	4.4	4.3	4.6	2.8	3.7	13.4	33.3		
	R	o	c	k	i	n	g	h	a	m	D 2000		
	21.4	4.7	4.4	4.3	4.6	2.2	4.4	4.8	4.4	4.6	5.9	6.4	44.3

APPROVED: *[Signature]*
DATE: 8-7-2012

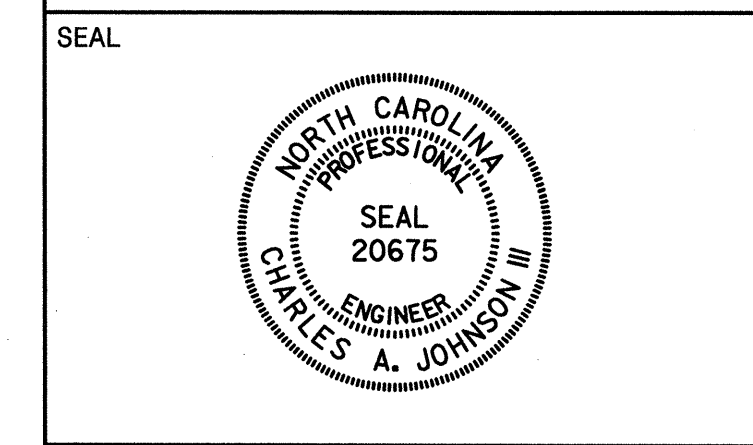

SIGN NUMBER: 306 BACKG COLOR: Green / Green
TYPE: D COPY COLOR: White

DESIGN BY: TRT CHECKED BY: ADK/CAJ
PROJECT ID: R-3421C DIV: 08 DATE: May 2012

SYMBOL	X	Y	WID	HT
Arrow Straight	7.9	17.8	6	9
Arrow Right	51.2	4.7	6	9

SIGN WIDTH: 6'-0"
HEIGHT: 2'-6"
TOTAL AREA: 15.0 Sq.Ft.

BORDER TYPE: FLUSH
RECESS: 0"
WIDTH: 0.75"
RADII: 2.25"

MAT'L: 0.125" ALUMINUM

NO. Z BARS:
LENGTH:

NOTES:
1. Legend and border shall be direct applied Grade C reflective sheeting.
2. Background shall be Grade C reflective sheeting.

BORDER R=2.25" TH=0.75"

Spacing Factor is 1 unless specified otherwise

LETTER POSITIONS

Letter spacings are to start of next letter													Series/Size
													Text Length
	R	o	c	k	i	n	g	h	a	m			D 2000
19.9	4.7	4.4	4.3	4.6	2.2	4.4	4.8	4.4	4.6	5.9	7.9		44.3
	A	s	h	e	b	o	r	o					D 2000
11.8	5.5	3.6	4.4	4.4	4.3	4.6	2.8	3.7	26.9				33.3

SIGN NUMBER: 307 BACKG COLOR: Green
TYPE: D COPY COLOR: White

DESIGN BY: TRT CHECKED BY: ADK/CAJ
PROJECT ID: R-3421C DIV: 08 DATE: May 2012

SYMBOL	X	Y	WID	HT

SIGN WIDTH: 7'-0"
HEIGHT: 3'-0"
TOTAL AREA: 21.0 Sq.Ft.

BORDER TYPE: FLUSH
RECESS: 0"
WIDTH: 1"
RADII: 3"

MAT'L: 0.125" ALUMINUM

NO. Z BARS:
LENGTH:











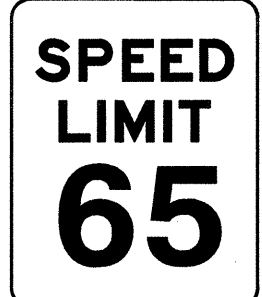

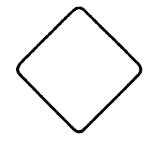

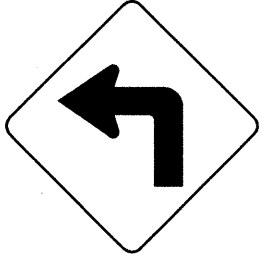
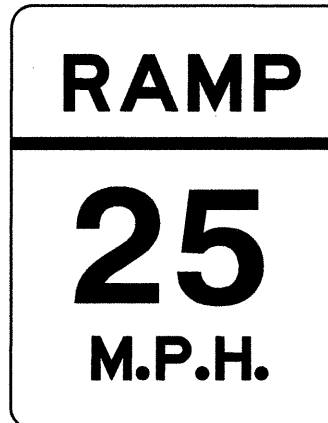

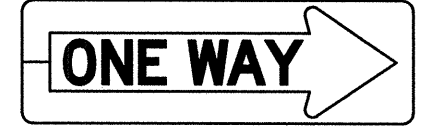
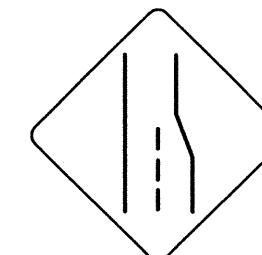
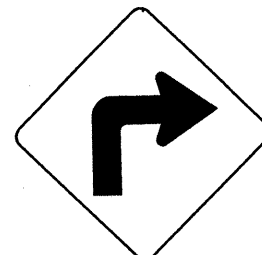
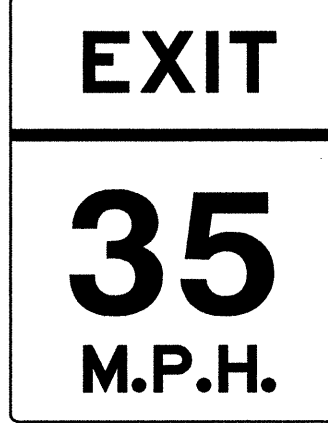

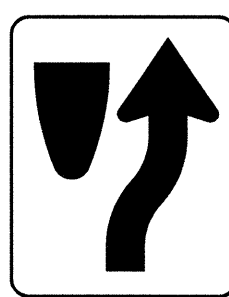
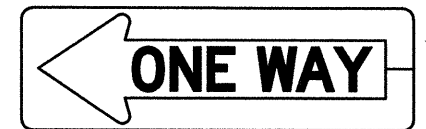
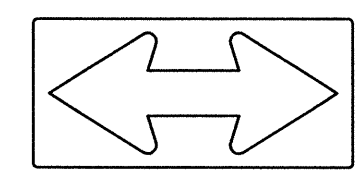
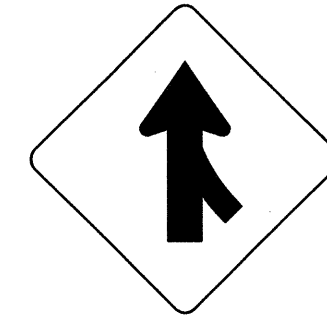
NOTES:
1. Legend and border shall be direct applied Grade C reflective sheeting.
2. Background shall be Grade C reflective sheeting.

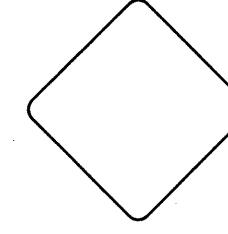
BORDER R=3" TH=1"

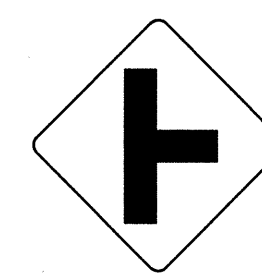
Spacing Factor is 1 unless specified otherwise

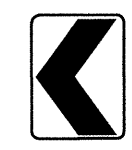
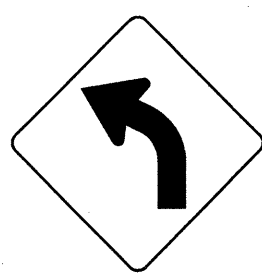
LETTER POSITIONS

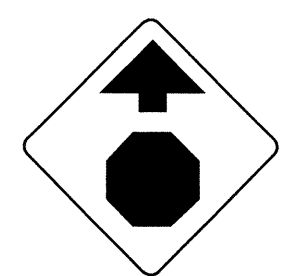
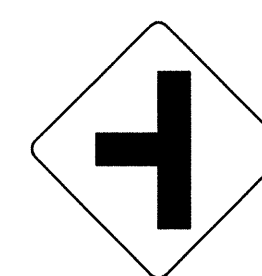
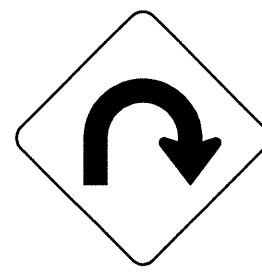
Letter spacings are to start of next letter													Series/Size
													Text Length
	C	a	n	d	o	r							D 2000
9.6	6.6	6.1	5.9	6.1	6.2	3	40.5						33.9
	1	9											D 2000
65.2	3.8	5.4	9.6										9.2
	A	s	h	e	b	o	r	o					D 2000
9.6	7.4	4.8	5.9	5.8	5.8	6.2	3.7	4.9	30				44.4
	5	2											D 2000
62	7	5.4	9.6										12.5

<p>401 QUANTITY REQ'D 5</p>  <p>48" X 60" R2-1</p> <p>TWO "U" POSTS PER SIGN</p>	<p>406 QUANTITY REQ'D 4</p>  <p>36" X 24" R5-1a</p> <p>ONE "U" POST PER SIGN</p>	<p>411 QUANTITY REQ'D 3</p>  <p>18" X 18" OM1-3</p> <p>MOUNT BELOW SIGN 410 IN 3 INSTALLATIONS</p>	<p>416 QUANTITY REQ'D 1</p>  <p>48" X 48" W9-1R</p> <p>TWO "U" POSTS PER SIGN</p>	<p>421 QUANTITY REQ'D 4</p>  <p>36" X 36" W1-1 (L)</p> <p>ONE "U" POST PER SIGN</p>	<p>426 QUANTITY REQ'D 1</p>  <p>36" X 48" W13-3</p> <p>TWO "U" POSTS PER SIGN</p>
<p>402 QUANTITY REQ'D 6</p>  <p>36" X 48" R2-1</p> <p>TWO "U" POSTS PER SIGN</p>	<p>407 QUANTITY REQ'D 20</p>  <p>36" X 36" R1-1</p> <p>ONE "U" POST PER SIGN MOUNT BELOW SIGN 412 IN 2 INSTALLATIONS</p>	<p>412 QUANTITY REQ'D 4</p>  <p>54" X 18" R6-1 (R)</p> <p>TWO "U" POSTS PER SIGN MOUNT WITH SIGN 407 IN 2 INSTALLATIONS</p>	<p>417 QUANTITY REQ'D 1</p>  <p>48" X 48" W4-2R</p> <p>TWO "U" POSTS PER SIGN</p>	<p>422 QUANTITY REQ'D 1</p>  <p>36" X 36" W1-1 (R)</p> <p>ONE "U" POST PER SIGN</p>	<p>427 QUANTITY REQ'D 1</p>  <p>36" X 48" W13-2</p> <p>TWO "U" POSTS PER SIGN</p>
<p>403 QUANTITY REQ'D 2</p>  <p>30" X 36" R2-1</p> <p>ONE "U" POST PER SIGN</p>	<p>408 QUANTITY REQ'D 2</p>  <p>36" X 48" R4-7</p> <p>TWO "U" POSTS PER SIGN</p>	<p>413 QUANTITY REQ'D 4</p>  <p>54" X 18" R6-1 (L)</p> <p>TWO "U" POSTS PER SIGN MOUNT ON BACK OF SIGN 412 IN 2 INSTALLATIONS</p>	<p>418 QUANTITY REQ'D 10</p>  <p>48" X 24" W1-7</p> <p>TWO "U" POSTS PER SIGN</p>	<p>423 QUANTITY REQ'D 2</p>  <p>48" X 48" W4-1 (R)</p> <p>TWO "U" POSTS PER SIGN</p>	<p>428 QUANTITY REQ'D 5</p>  <p>18" X 24" W1-8 (R)</p> <p>ONE "U" POST PER SIGN</p>
<p>404 QUANTITY REQ'D 2</p>  <p>48" X 48" W3-5</p> <p>TWO "U" POSTS PER SIGN</p>	<p>409 QUANTITY REQ'D 2</p>  <p>24" X 24" OM1-3</p> <p>MOUNT BELOW SIGN 408 IN 2 INSTALLATIONS</p>	<p>414 QUANTITY REQ'D 2</p>  <p>36" X 36" R5-1</p> <p>ONE "U" POST PER SIGN MOUNT WITH SIGN 407 IN 2 INSTALLATIONS</p>	<p>419 QUANTITY REQ'D 1</p>  <p>36" X 36" W2-2 (R)</p> <p>ONE "U" POST PER SIGN</p>	<p>424 QUANTITY REQ'D 5</p>  <p>36" X 36" W14-2</p> <p>ONE "U" POST PER SIGN</p>	<p>429 QUANTITY REQ'D 4</p>  <p>18" X 24" W1-8 (L)</p> <p>ONE "U" POST PER SIGN</p>
<p>405 QUANTITY REQ'D 11</p>  <p>36" X 36" W1-2 (L)</p> <p>ONE "U" POST PER SIGN</p>	<p>410 QUANTITY REQ'D 3</p>  <p>24" X 30" R4-7</p> <p>ONE "U" POST PER SIGN</p>	<p>415 QUANTITY REQ'D 7</p>  <p>36" X 36" W3-1</p> <p>ONE "U" POST PER SIGN</p>	<p>420 QUANTITY REQ'D 1</p>  <p>36" X 36" W2-2 (L)</p> <p>ONE "U" POST PER SIGN</p>	<p>425 QUANTITY REQ'D 1</p>  <p>48" X 48" W1-11R</p> <p>TWO "U" POSTS PER SIGN</p>	<p>430 QUANTITY REQ'D 1</p>  <p>18" X 18" W13-1P</p> <p>MOUNT BELOW SIGN 421 IN 1 INSTALLATION</p>

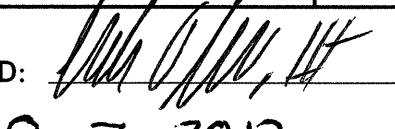
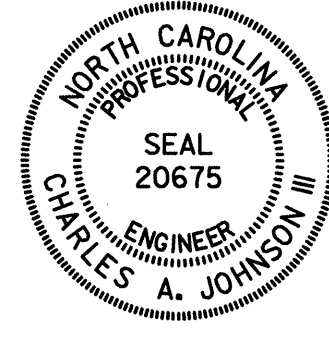
TIP NO. R-3421C	SHEET NO. SIGN-4F
APPROVED: 	
DATE: 8-7-2012	
SEAL	
	

431 QUANTITY REQ'D 1



18" X 18"
W13-1P

MOUNT BELOW SIGN 421 IN 1 INSTALLATION

432 QUANTITY REQ'D 3



18" X 18"
W13-1P

MOUNT BELOW SIGNS 421 AND 422 IN 3 INSTALLATIONS

433 QUANTITY REQ'D 1



18" X 18"
W13-1P

MOUNT BELOW SIGN 405 IN 1 INSTALLATION

434 QUANTITY REQ'D 18



18" X 18"
W13-1P

MOUNT BELOW SIGNS 405 AND 435 IN 18 INSTALLATIONS

435 QUANTITY REQ'D 8

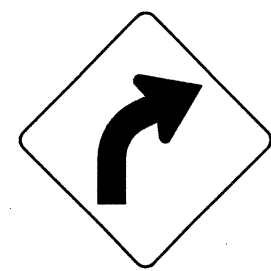

36" X 36"
W1-2 (R)

ONE "U" POST PER SIGN

436 QUANTITY REQ'D 1



24" X 24"
W13-1P

MOUNT BELOW SIGN 425 IN 1 INSTALLATION

TIP NO. SHEET NO.
R-3421C SIGN-4G

APPROVED: *[Signature]*
DATE: 8-7-2012

SEAL

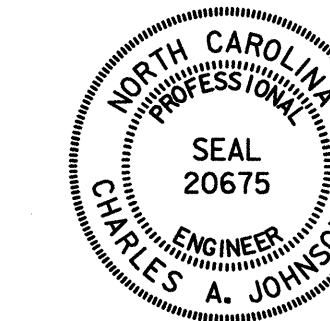

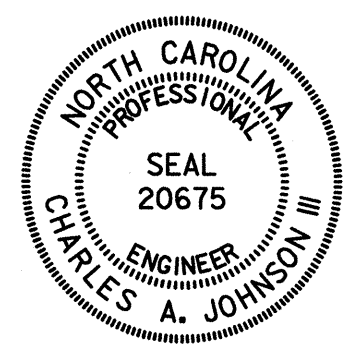
TIP NO. R-3421C	SHEET NO. SIGN-4H
APPROVED: <i>[Signature]</i>	
DATE: 8-7-2012	
SEAL	
	

501

NORTH
220
1 - 30" X 15"
1 - 45" X 36"

ONE "U" POST PER SIGN

506

SOUTH **EAST**
INTERSTATE 73 INTERSTATE 74
2 - 24" X 12"
2 - 24" X 24"
↑ ↑
2 - 21" X 15"
NORTH **WEST**
2 - 24" X 12"
INTERSTATE 73 INTERSTATE 74
2 - 24" X 24"
→ →
2 - 21" X 15"

TWO "U" POSTS PER SIGN

511 512

JCT 1 - 21" X 15"
INTERSTATE 73
1 - 24" X 24"
JCT **JCT**
INTERSTATE 74 INTERSTATE 220
2 - 21" X 15"
1 - 24" X 24"
1 - 30" X 24"

TWO "U" POSTS PER SIGN

NORTH
73
MILE 23
18" X 54"

ONE "U" POST PER SIGN

NORTH
73
MILE 25
18" X 54"

ONE "U" POST PER SIGN

502

SOUTH
220
1 - 30" X 15"
1 - 45" X 36"

ONE "U" POST PER SIGN

507

SOUTH
INTERSTATE 73
1 - 24" X 12"
1 - 24" X 24"
→
1 - 21" X 15"
EAST **SOUTH**
INTERSTATE 74 INTERSTATE 220
2 - 24" X 12"
1 - 24" X 24"
1 - 30" X 24"
→ →
2 - 21" X 15"

TWO "U" POSTS PER SIGN

513

SOUTH **NORTH**
220 220
2 - 24" X 12"
2 - 30" X 24"
↑ →
2 - 21" X 15"

MOUNT BELOW SIGN 306 IN 1 INSTALLATION

SOUTH
73
MILE 23
18" X 54"

ONE "U" POST PER SIGN

SOUTH
73
MILE 25
18" X 54"

ONE "U" POST PER SIGN

503

END **END**
INTERSTATE 73 INTERSTATE 74
2 - 30" X 15"
2 - 36" X 36"

TWO "U" POSTS PER SIGN

508

SOUTH **NORTH**
220 220
2 - 24" X 12"
2 - 30" X 24"
← ↑
2 - 21" X 15"

MOUNT BELOW SIGN 305 IN 1 INSTALLATION

NORTH
73
MILE 24
18" X 54"

ONE "U" POST PER SIGN

504 514

NORTH
INTERSTATE 73
1 - 30" X 15"
1 - 36" X 36"
WEST **NORTH**
INTERSTATE 74 INTERSTATE 220
2 - 30" X 15"
1 - 36" X 36"
1 - 45" X 36"

TWO "U" POSTS PER SIGN

509

NORTH **WEST**
INTERSTATE 73 INTERSTATE 74
2 - 24" X 12"
2 - 24" X 24"
↑ ↑
2 - 21" X 15"
SOUTH **EAST**
INTERSTATE 73 INTERSTATE 74
2 - 24" X 12"
2 - 24" X 24"
← ←
2 - 21" X 15"

TWO "U" POSTS PER SIGN

SOUTH
73
MILE 24
18" X 54"

ONE "U" POST PER SIGN

505

NORTH
INTERSTATE 73
1 - 24" X 12"
1 - 24" X 24"
←
1 - 21" X 15"
WEST **NORTH**
INTERSTATE 74 INTERSTATE 220
2 - 24" X 12"
1 - 24" X 24"
1 - 30" X 24"
← ←
2 - 21" X 15"

TWO "U" POSTS PER SIGN

510 515

SOUTH
INTERSTATE 73
1 - 30" X 15"
1 - 36" X 36"
EAST **SOUTH**
INTERSTATE 74 INTERSTATE 220
2 - 30" X 15"
1 - 36" X 36"
1 - 45" X 36"

TWO "U" POSTS PER SIGN

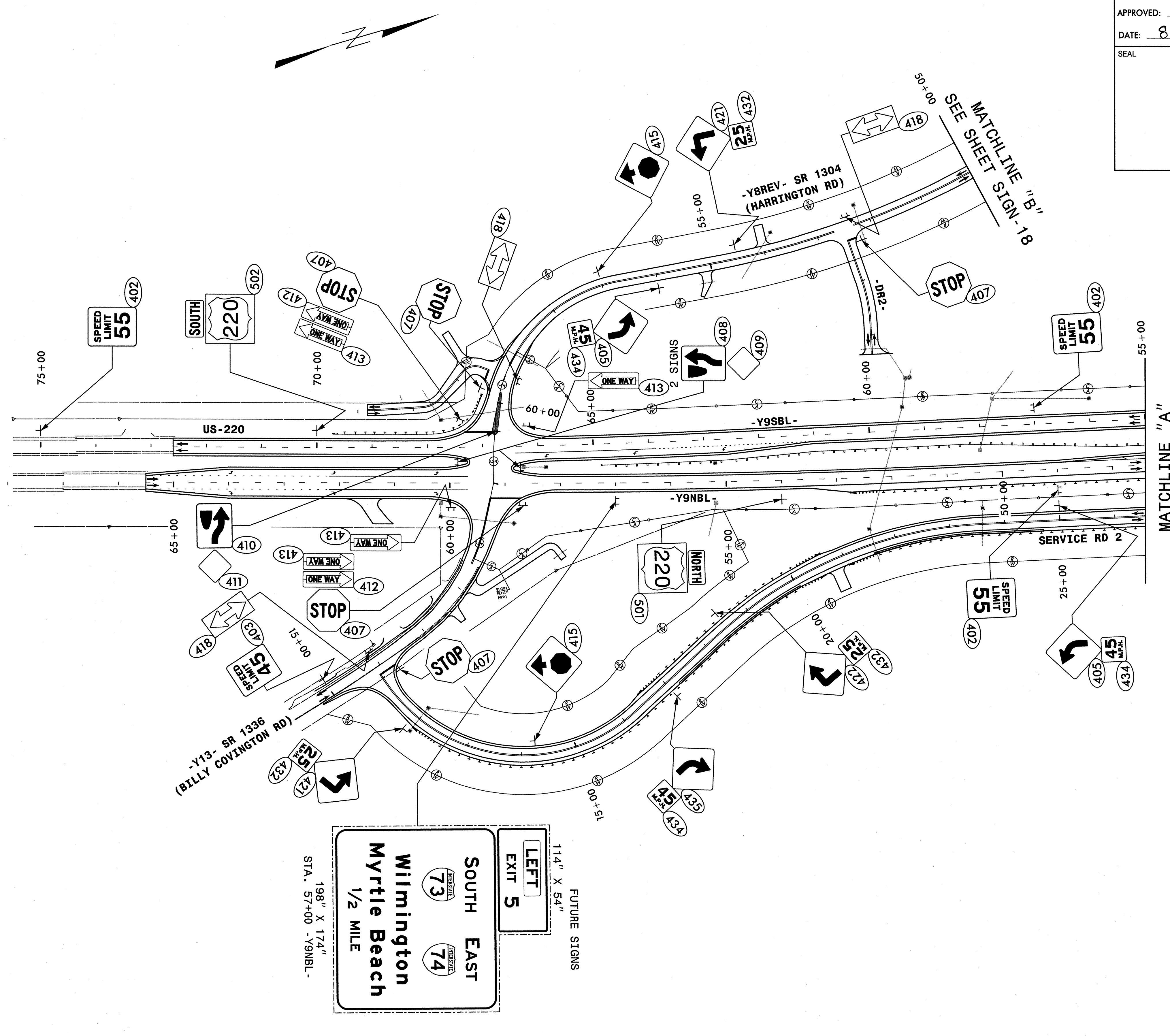

114" X 54"
FUTURE SIGNS

LEFT EXIT 5	SOUTH EAST
	73 74
	Wilmington
	Myrtle Beach
	1/2 MILE

198" X 174"
STA. 57+00 - Y9NBL-

NOTE:
REMOVE AND DISPOSE OF EXISTING SIGNS WITHIN PROJECT LIMITS UNLESS OTHERWISE NOTED.
ALL PROPOSED SIGNS SEE NOTE 5 UNLESS OTHERWISE NOTED.

HNTB HNTB NORTH CAROLINA, P.C.
343 E. Six Forks Road, Suite 200
Raleigh, North Carolina 27609
NC License No: C-1554

PROPOSED SIGNS
STA. 75+00 TO 55+00 -Y9SBL-

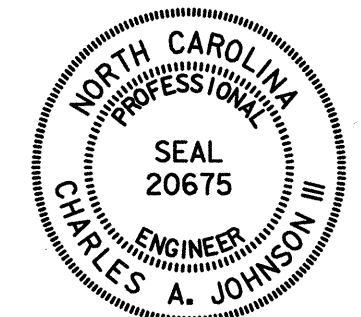
TIP NO. R-3421C	SHEET NO. SIGN-6
APPROVED: <i>[Signature]</i>	
DATE: 8-7-2012	
SEAL	
	

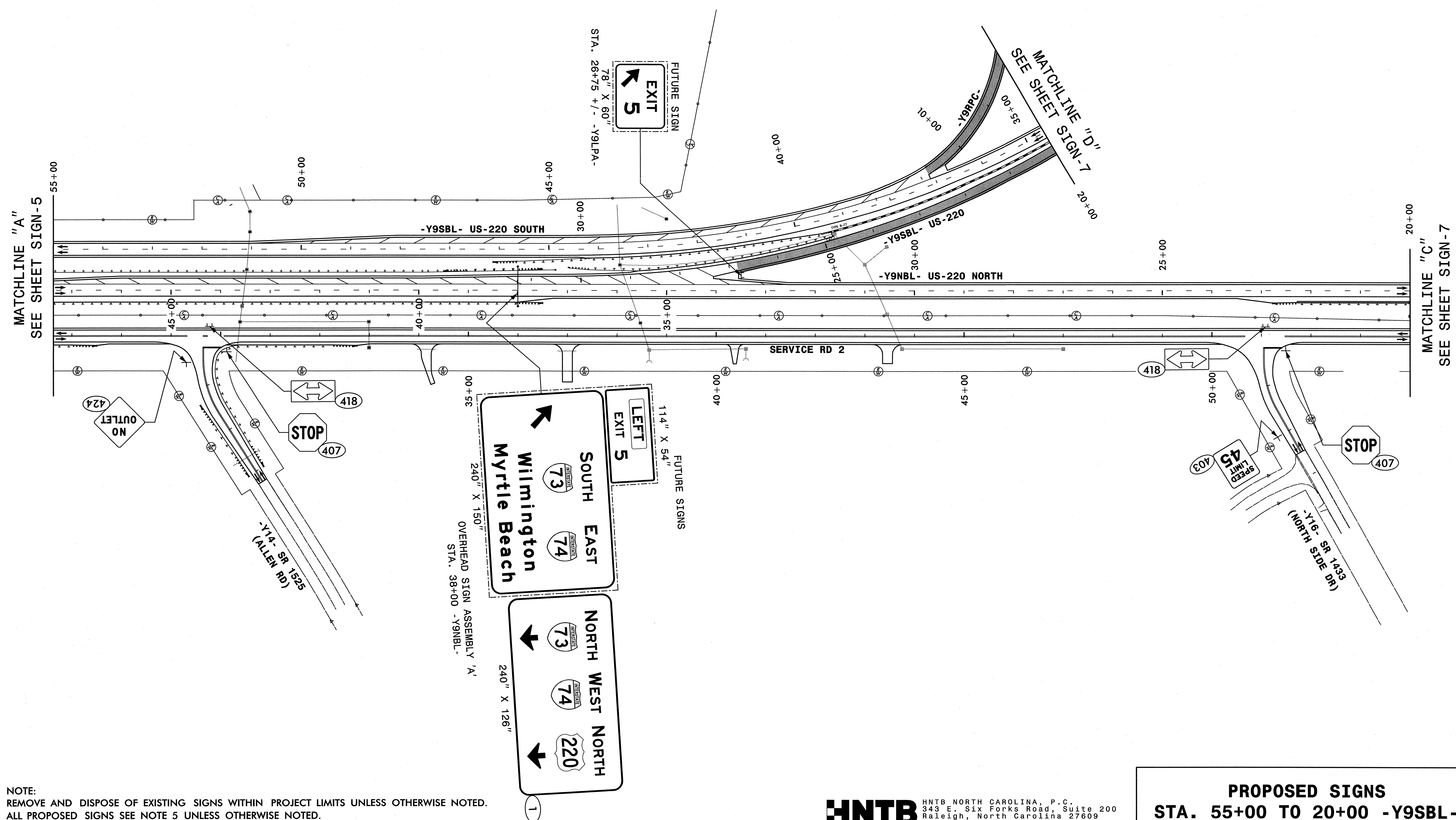
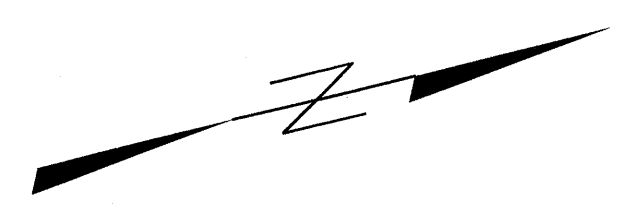

NOTE:
REMOVE AND DISPOSE OF EXISTING SIGNS WITHIN PROJECT LIMITS UNLESS OTHERWISE NOTED.
ALL PROPOSED SIGNS SEE NOTE 5 UNLESS OTHERWISE NOTED.

PROPOSED SIGNS
STA. 55+00 TO 20+00 -Y9SBL-

HNTB HNTB NORTH CAROLINA, P.C.
343 E. Six Forks Road, Suite 200
Raleigh, North Carolina 27609
NC License No: C-1554

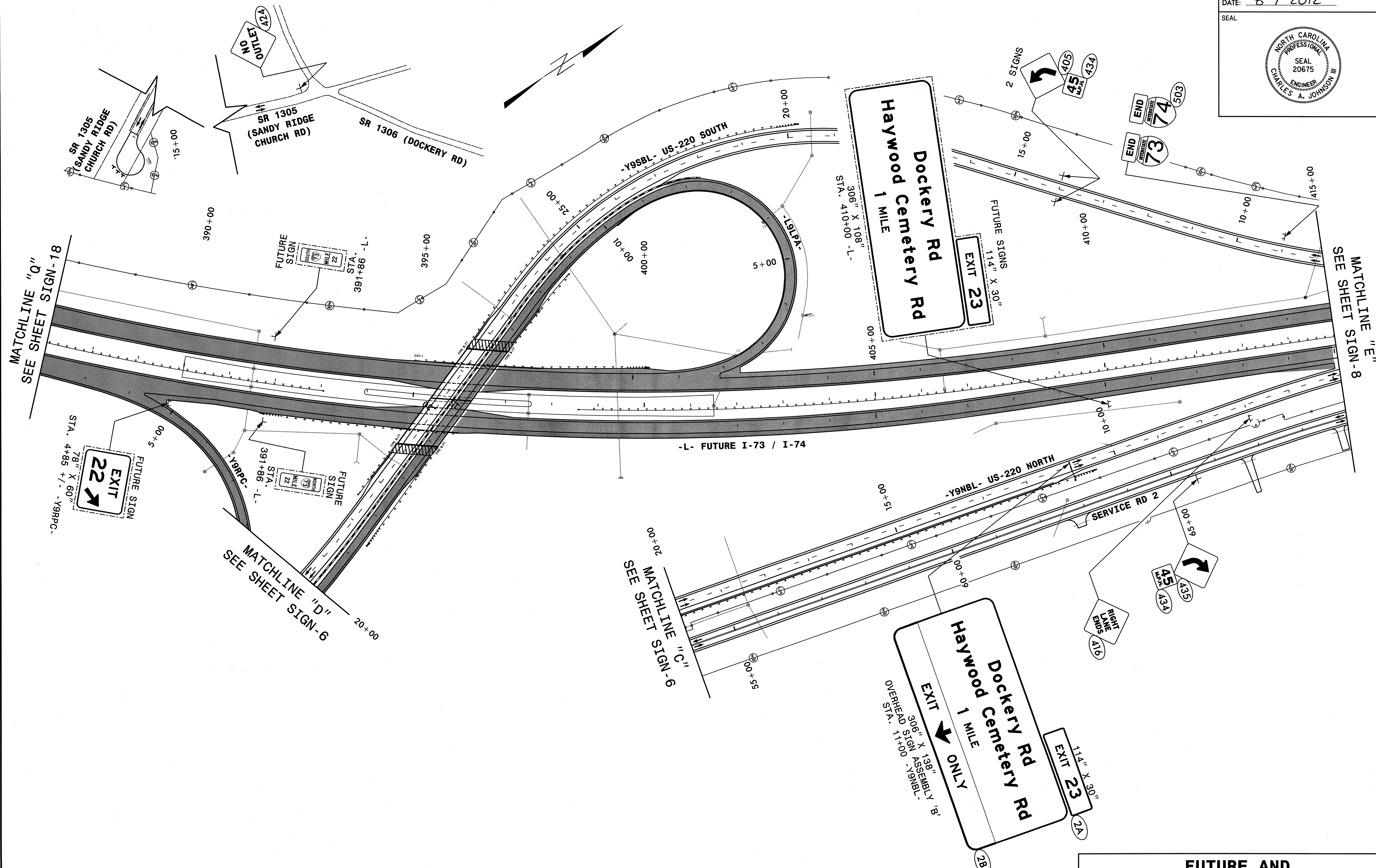

NOTE:
 REMOVE AND DISPOSE OF EXISTING SIGNS WITHIN PROJECT LIMITS UNLESS OTHERWISE NOTED.
 ALL PROPOSED SIGNS SEE NOTE 5 UNLESS OTHERWISE NOTED.

HNTB HNTB NORTH CAROLINA, P.C.
 343 E. Six Forks Road, Suite 200
 Raleigh, North Carolina 27609
 NC License No: C-1554

FUTURE AND PROPOSED SIGNS
 STA. 387+00 TO 415+00 -L-

MATCHLINE "E"
SEE SHEET SIGN-7

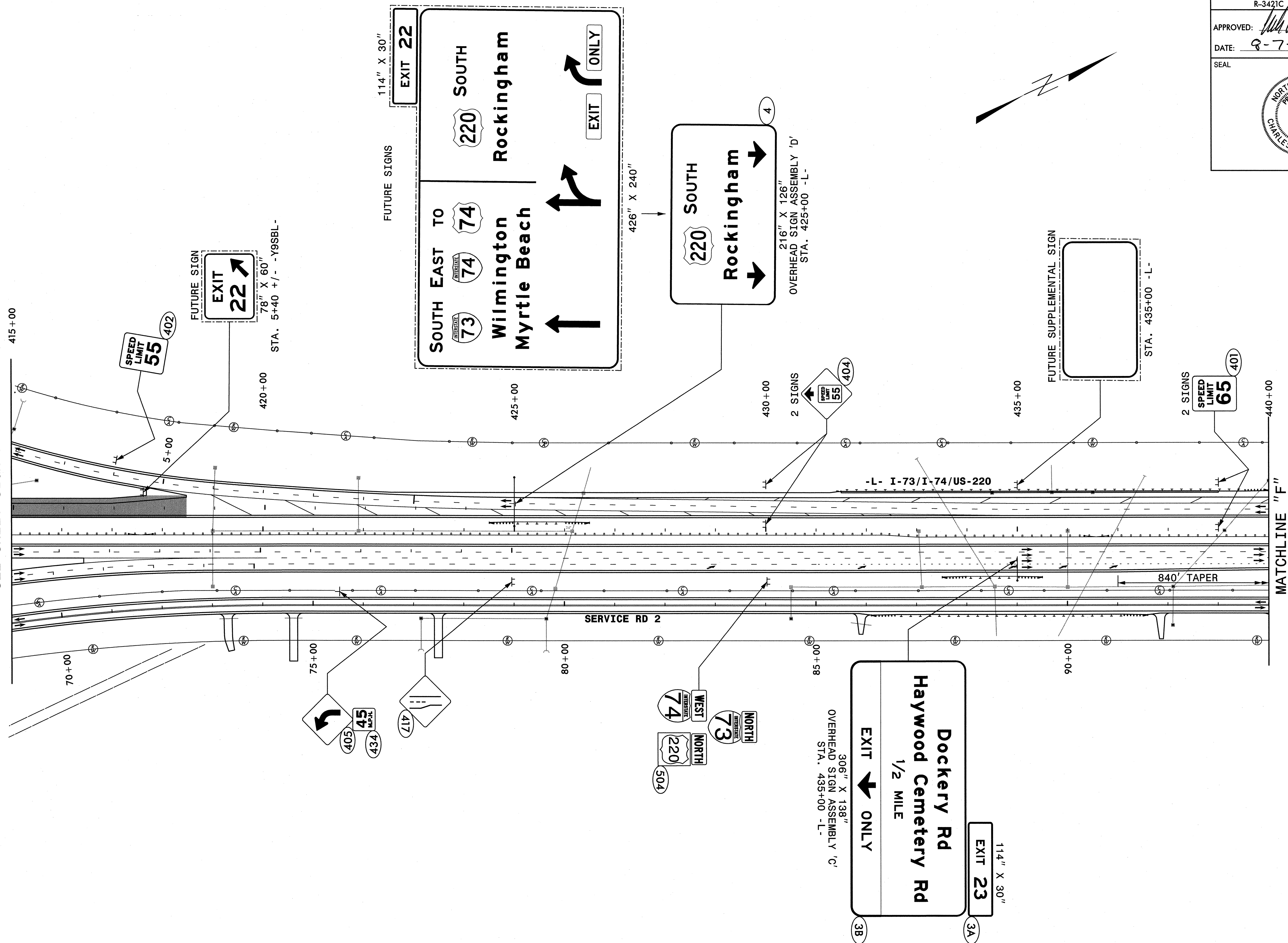

MATCHLINE "F"
SEE SHEET SIGN-9

NOTE:
REMOVE AND DISPOSE OF EXISTING SIGNS WITHIN PROJECT LIMITS UNLESS OTHERWISE NOTED.
ALL PROPOSED SIGNS SEE NOTE 5 UNLESS OTHERWISE NOTED.

PROPOSED SIGNS
STA. 415+00 TO 440+00 -L-

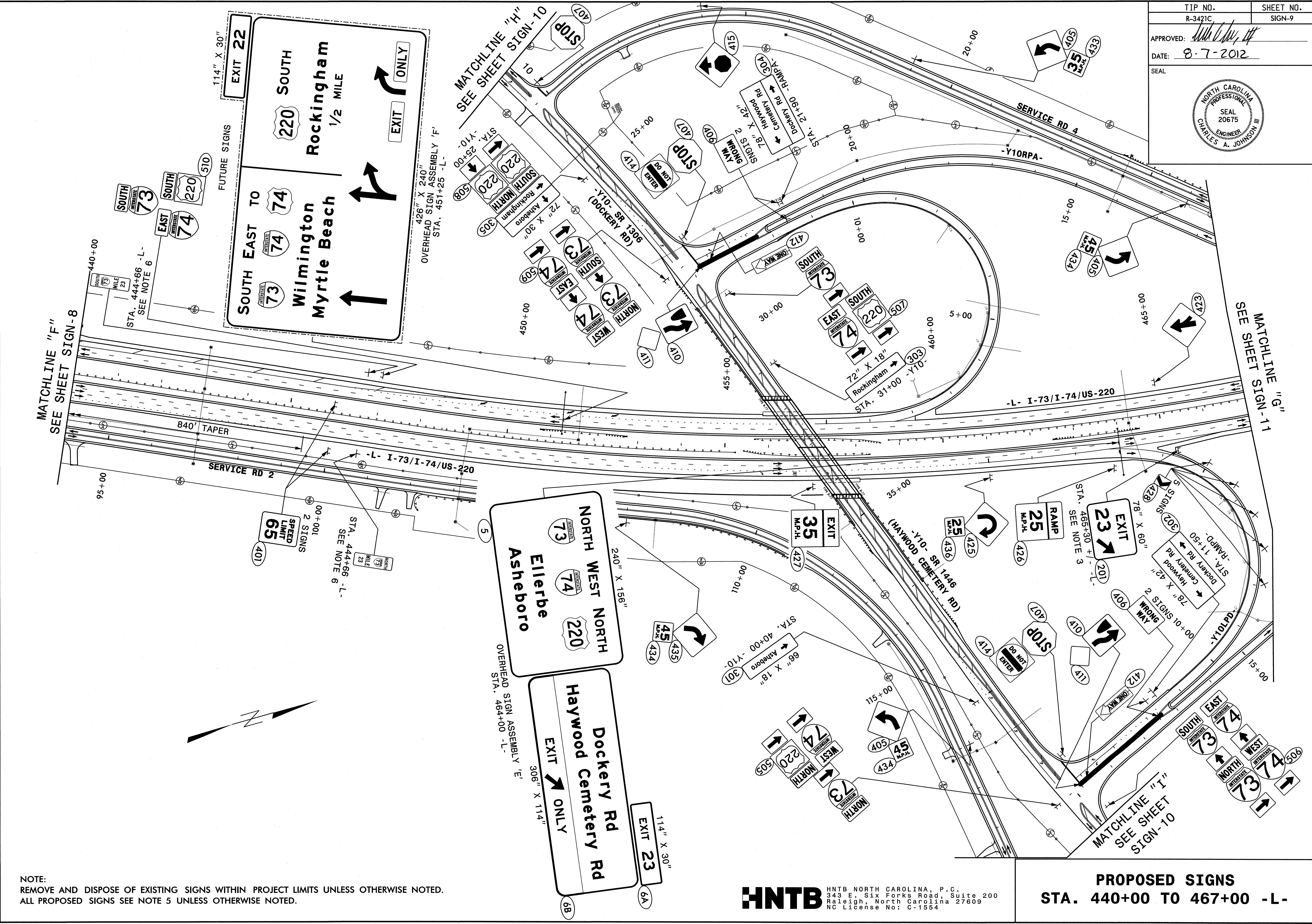

NOTE:
 REMOVE AND DISPOSE OF EXISTING SIGNS WITHIN PROJECT LIMITS UNLESS OTHERWISE NOTED.
 ALL PROPOSED SIGNS SEE NOTE 5 UNLESS OTHERWISE NOTED.

HNTB HNTB NORTH CAROLINA, P.C.
 343 E. Six Forks Road, Suite 200
 Raleigh, North Carolina 27609
 NC License No: C-1554

PROPOSED SIGNS
STA. 440+00 TO 467+00 -L-

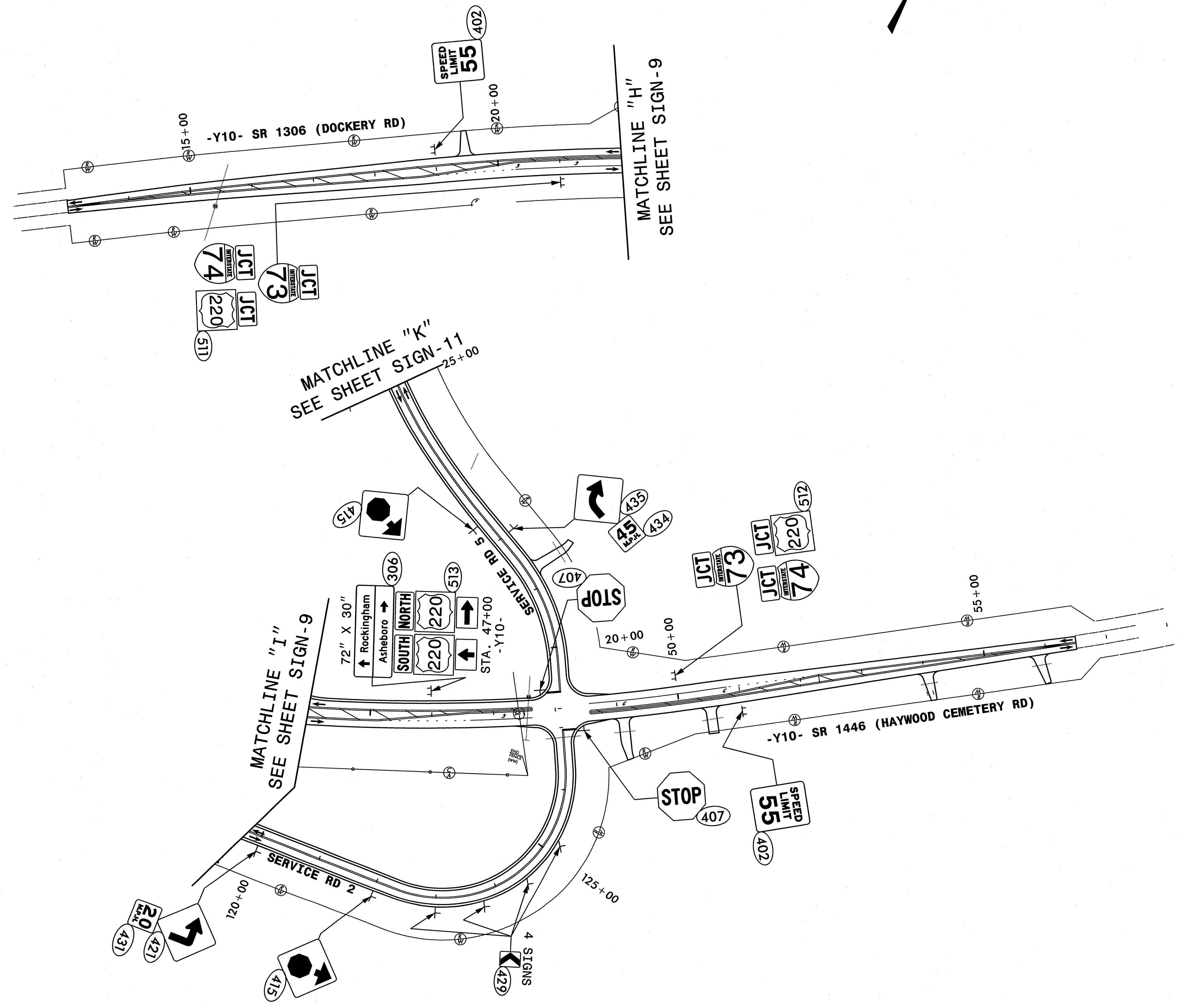

NOTE:
 REMOVE AND DISPOSE OF EXISTING SIGNS WITHIN PROJECT LIMITS UNLESS OTHERWISE NOTED.
 ALL PROPOSED SIGNS SEE NOTE 5 UNLESS OTHERWISE NOTED.

HNTB HNTB NORTH CAROLINA, P.C.
 343 E. Six Forks Road, Suite 200
 Raleigh, North Carolina 27609
 NC License No: C-1554

PROPOSED SIGNS
 STA. 13+00 TO 22+00 -Y10-
 STA. 44+00 TO 58+00 -Y10-

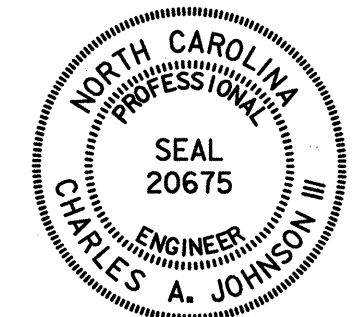
TIP NO. R-3421C	SHEET NO. SIGN-11
APPROVED: <i>[Signature]</i>	
DATE: 8-7-2012	
SEAL	
	

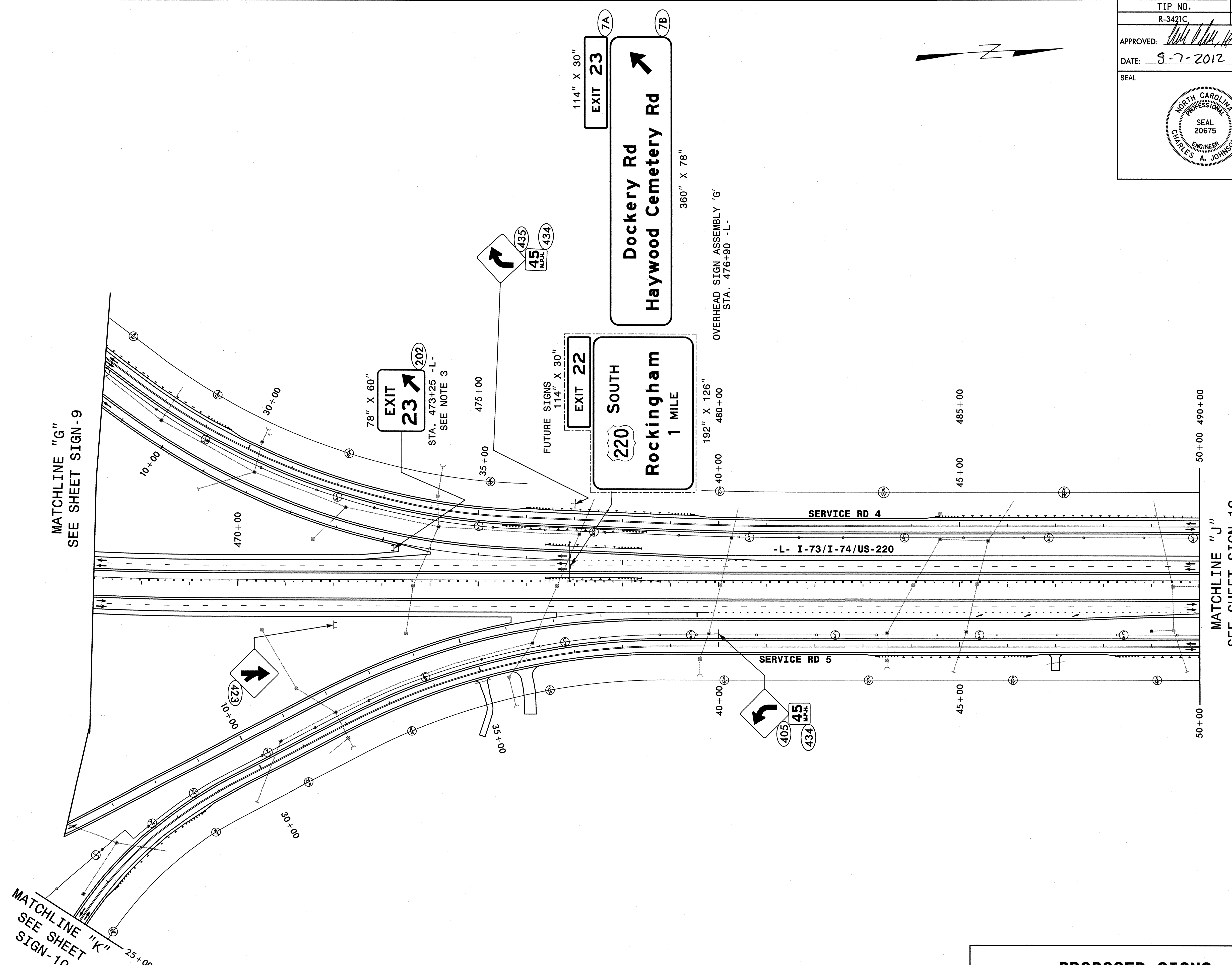
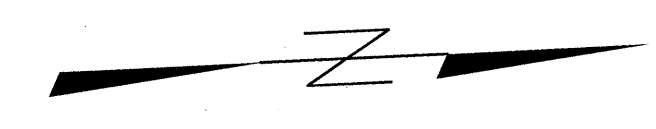

NOTE:
 REMOVE AND DISPOSE OF EXISTING SIGNS WITHIN PROJECT LIMITS UNLESS OTHERWISE NOTED.
 ALL PROPOSED SIGNS SEE NOTE 5 UNLESS OTHERWISE NOTED.

HNTB HNTB NORTH CAROLINA, P.C.
 343 E. Six Forks Road, Suite 200
 Raleigh, North Carolina 27609
 NC License No: C-1554

PROPOSED SIGNS
STA. 467+00 TO 490+00 -L-

MATCHLINE "G"
SEE SHEET SIGN-9

MATCHLINE "K"
SEE SHEET
SIGN-10

MATCHLINE "J"
SEE SHEET SIGN-12

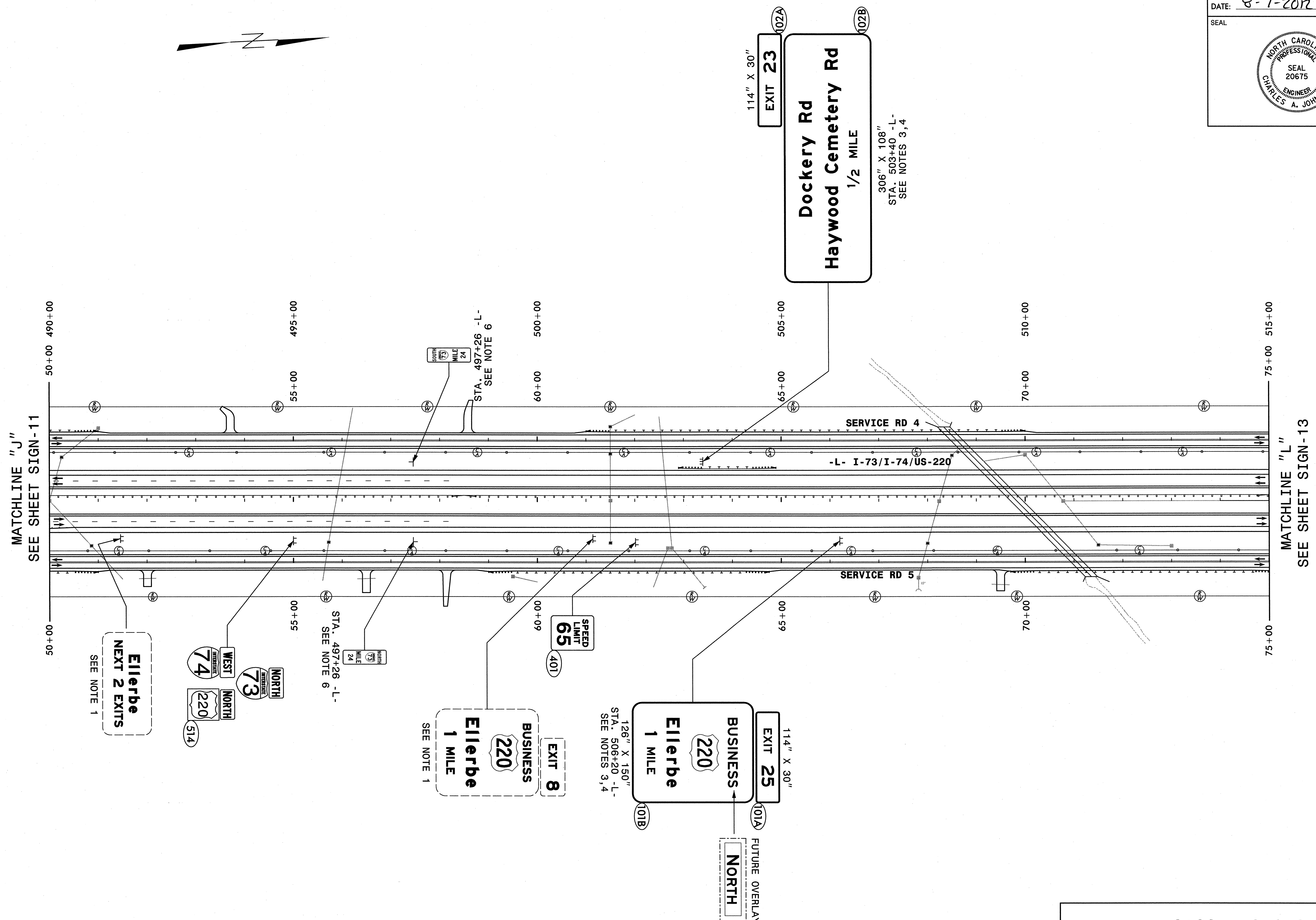

NOTE:
REMOVE AND DISPOSE OF EXISTING SIGNS WITHIN PROJECT LIMITS UNLESS OTHERWISE NOTED.
ALL PROPOSED SIGNS SEE NOTE 5 UNLESS OTHERWISE NOTED.

HNTB HNTB NORTH CAROLINA, P.C.
343 E. Six Forks Road, Suite 200
Raleigh, North Carolina 27609
NC License No: C-1554

PROPOSED SIGNS
STA. 490+00 TO 515+00 -L-

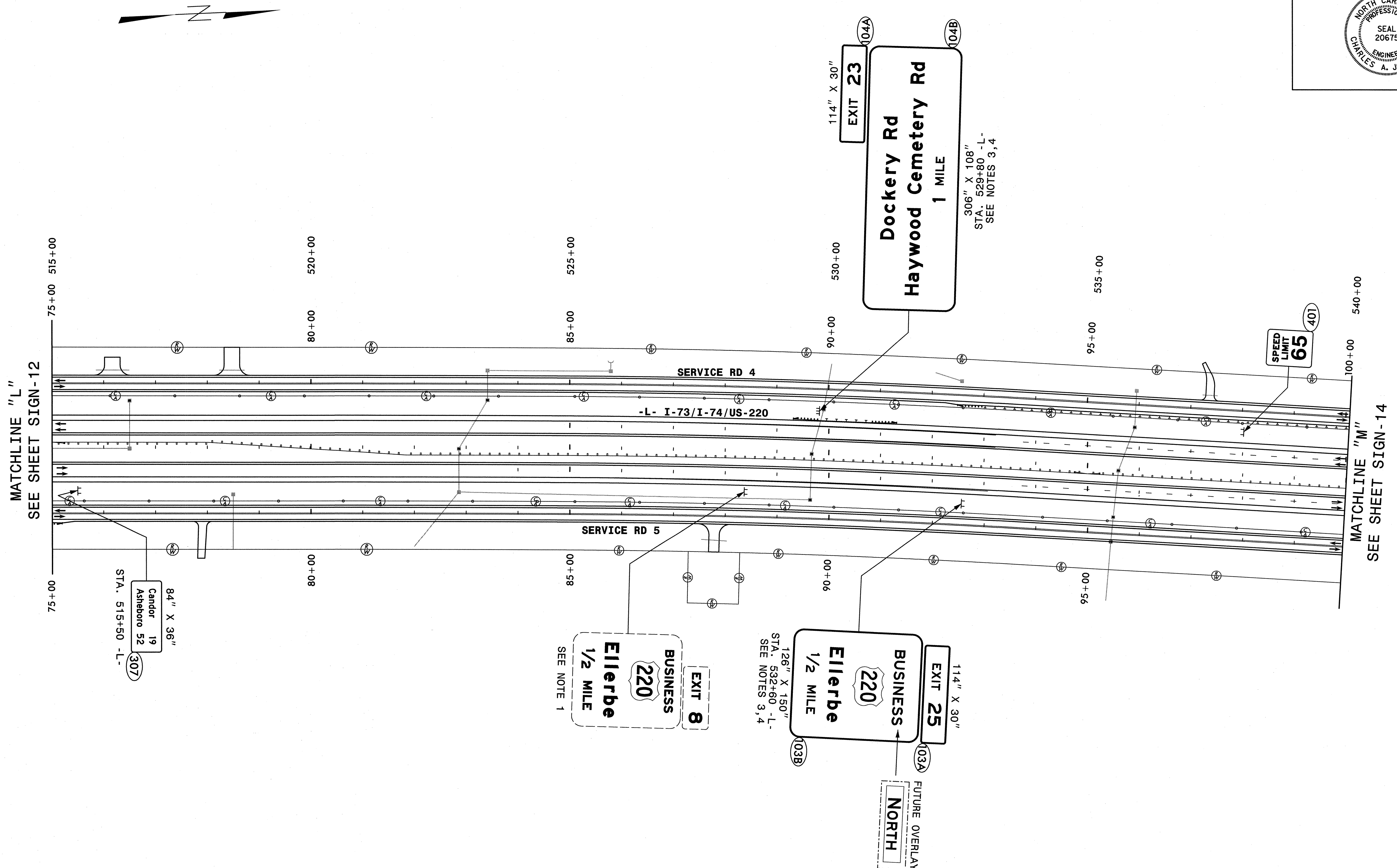

NOTE:
 REMOVE AND DISPOSE OF EXISTING SIGNS WITHIN PROJECT LIMITS UNLESS OTHERWISE NOTED.
 ALL PROPOSED SIGNS SEE NOTE 5 UNLESS OTHERWISE NOTED.

HNTB HNTB NORTH CAROLINA, P.C.
 343 E. Six Forks Road, Suite 200
 Raleigh, North Carolina 27609
 NC License No: C-1554

PROPOSED SIGNS
STA. 515+00 TO 540+00 -L-

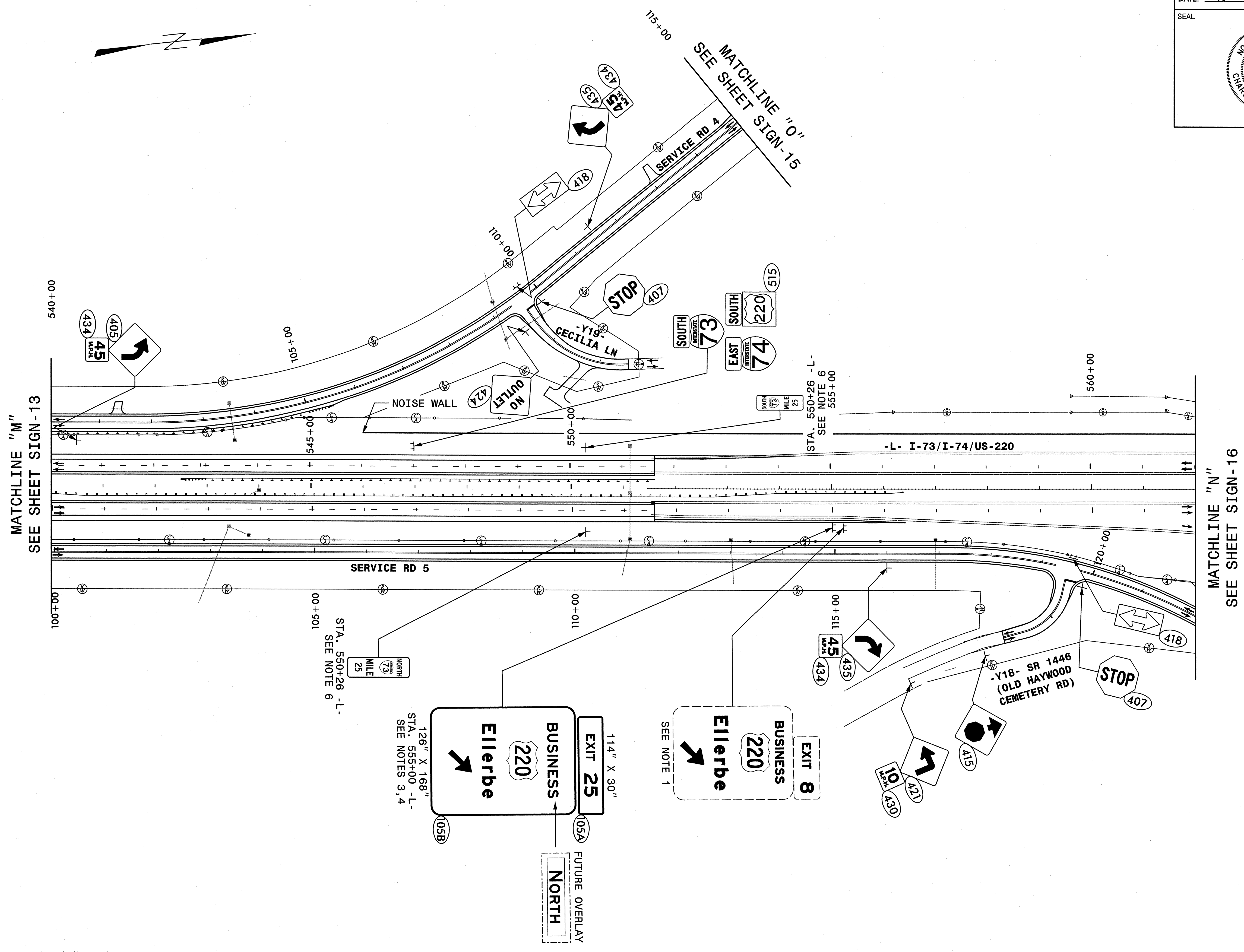
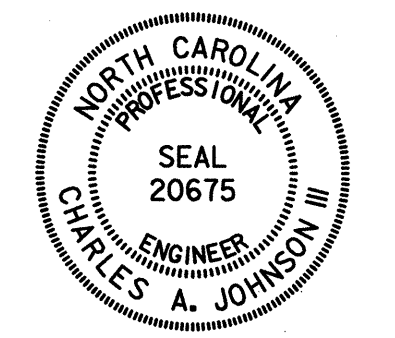

NOTE:
 REMOVE AND DISPOSE OF EXISTING SIGNS WITHIN PROJECT LIMITS UNLESS OTHERWISE NOTED.
 ALL PROPOSED SIGNS SEE NOTE 5 UNLESS OTHERWISE NOTED.

HNTB HNTB NORTH CAROLINA, P.C.
 343 E. Six Forks Road, Suite 200
 Raleigh, North Carolina 27609
 NC License No: C-1554

PROPOSED SIGNS
STA. 540+00 TO 562+00 -L-

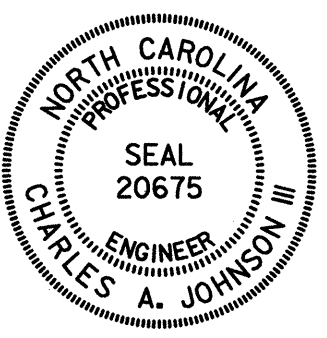
TIP NO. R-3421C	SHEET NO. SIGN-15
APPROVED: <i>[Signature]</i>	
DATE: 8-7-2012	
SEAL	
	

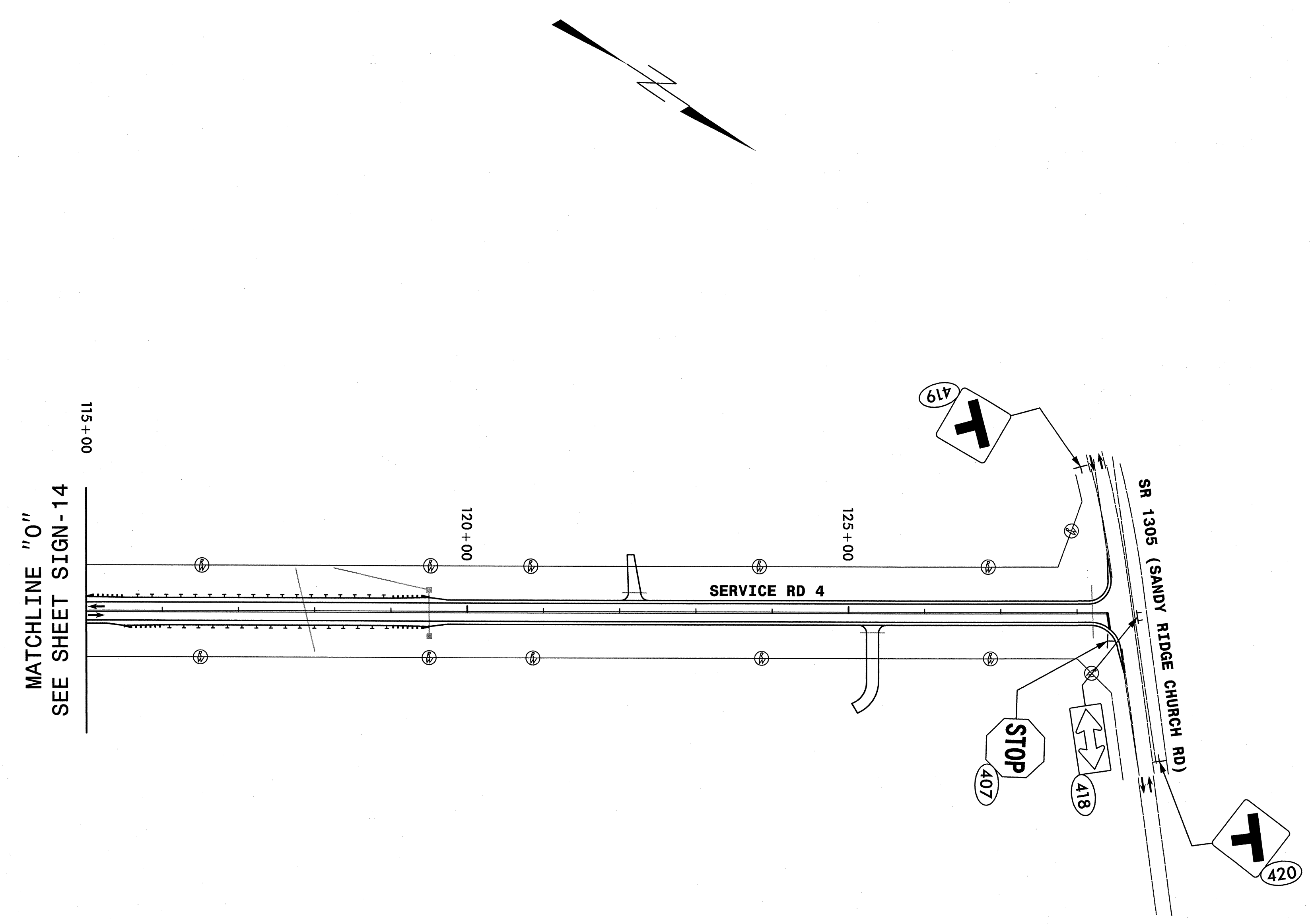

NOTE:
 REMOVE AND DISPOSE OF EXISTING SIGNS WITHIN PROJECT LIMITS UNLESS OTHERWISE NOTED.
 ALL PROPOSED SIGNS SEE NOTE 5 UNLESS OTHERWISE NOTED.

HNTB HNTB NORTH CAROLINA, P.C.
 343 E. Six Forks Road, Suite 200
 Raleigh, North Carolina 27609
 NC License No: C-1554

PROPOSED SIGNS
STA. 115+00 TO 127+50 -SR4-

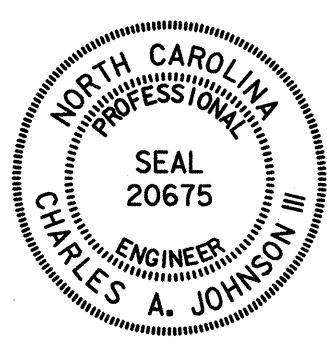
TIP NO. R-3421C	SHEET NO. SIGN-16
APPROVED: <i>[Signature]</i>	
DATE: 8-7-2012	
SEAL	
	

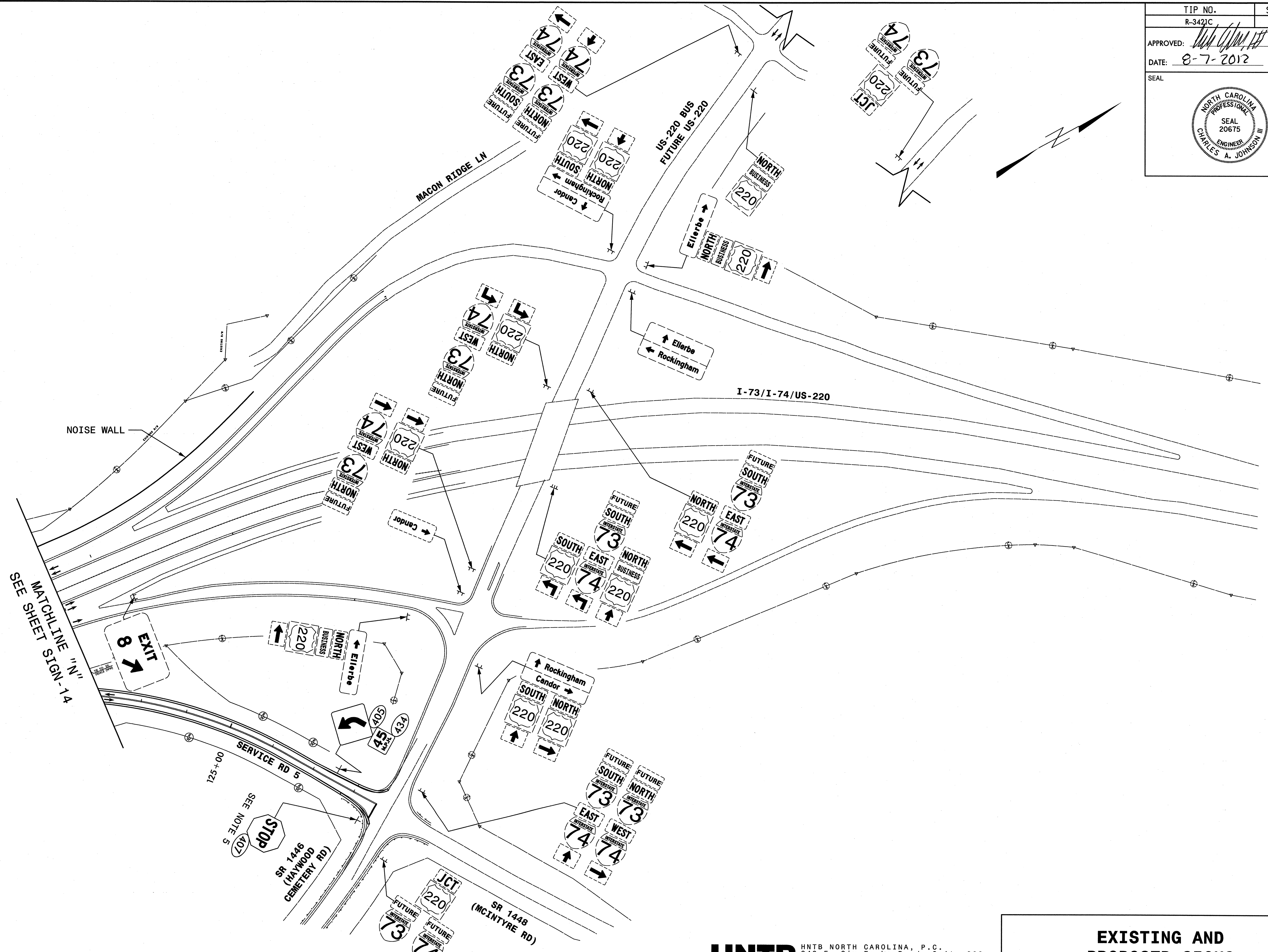

MATCHLINE "N"
SEE SHEET SIGN-14

125+00

SEE NOTE 5

SR 1446
(HAYWOOD
CEMETERY RD)

SR 1448
(MCINTYRE RD)

HNTB HNTB NORTH CAROLINA, P.C.
343 E. Six Forks Road, Suite 200
Raleigh, North Carolina 27609
NC License No: C-1554

**EXISTING AND
PROPOSED SIGNS**

TIP NO. R-3421C	SHEET NO. SIGN-17
APPROVED: <i>[Signature]</i>	
DATE: 8-7-2012	
SEAL	
	

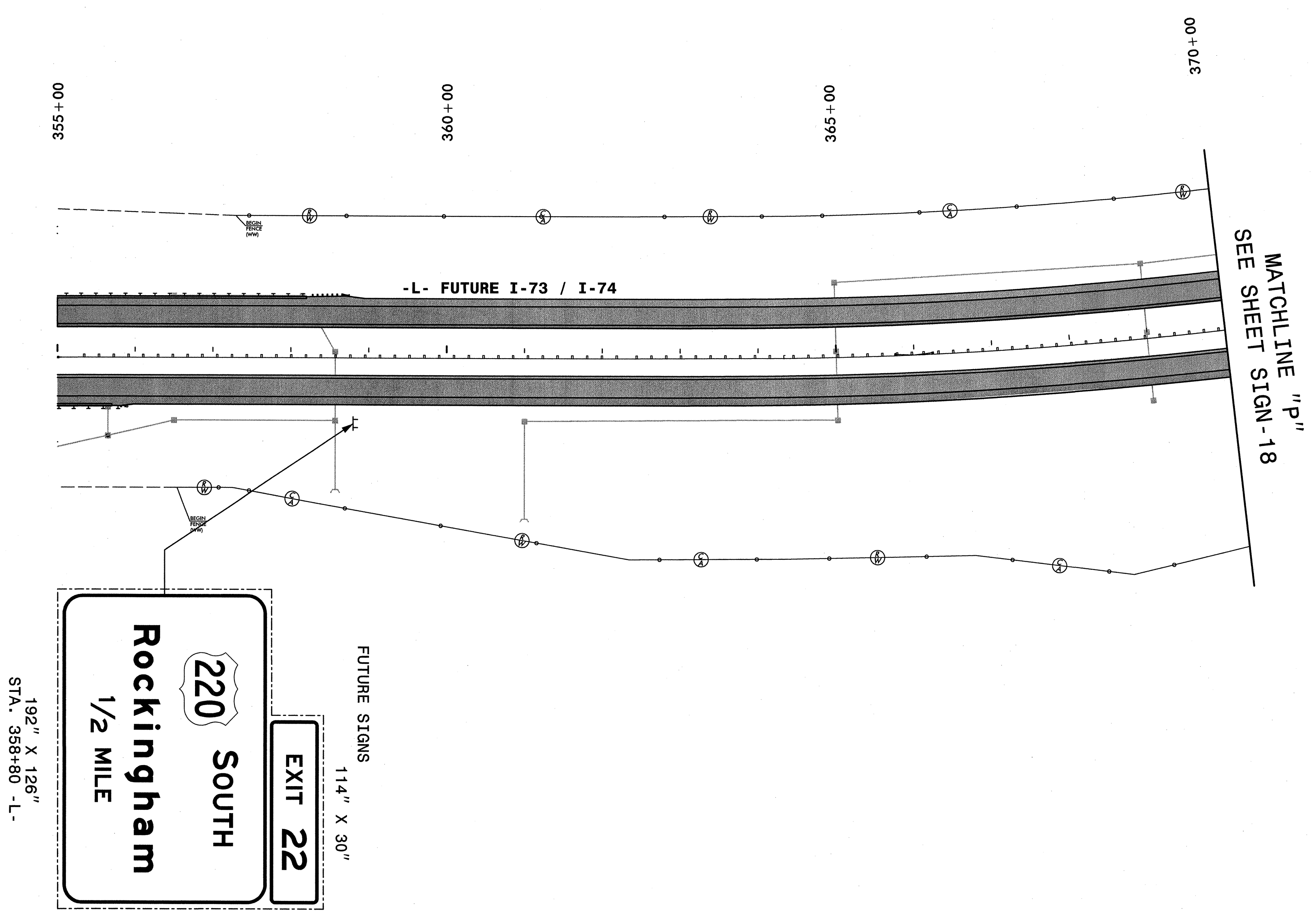
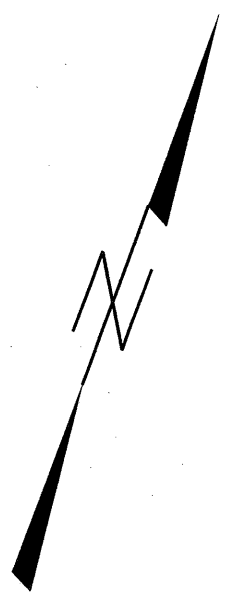

NOTE:
 REMOVE AND DISPOSE OF EXISTING SIGNS WITHIN PROJECT LIMITS UNLESS OTHERWISE NOTED.
 ALL PROPOSED SIGNS SEE NOTE 5 UNLESS OTHERWISE NOTED.

HNTB HNTB NORTH CAROLINA, P.C.
 343 E. Six Forks Road, Suite 200
 Raleigh, North Carolina 27609
 NC License No: C-1554

FUTURE SIGNS
STA. 355+00 TO 370+00 -L-

TIP NO. R-3421C	SHEET NO. SIGN-18
APPROVED: <i>[Signature]</i>	
DATE: 8-7-2012	
SEAL	

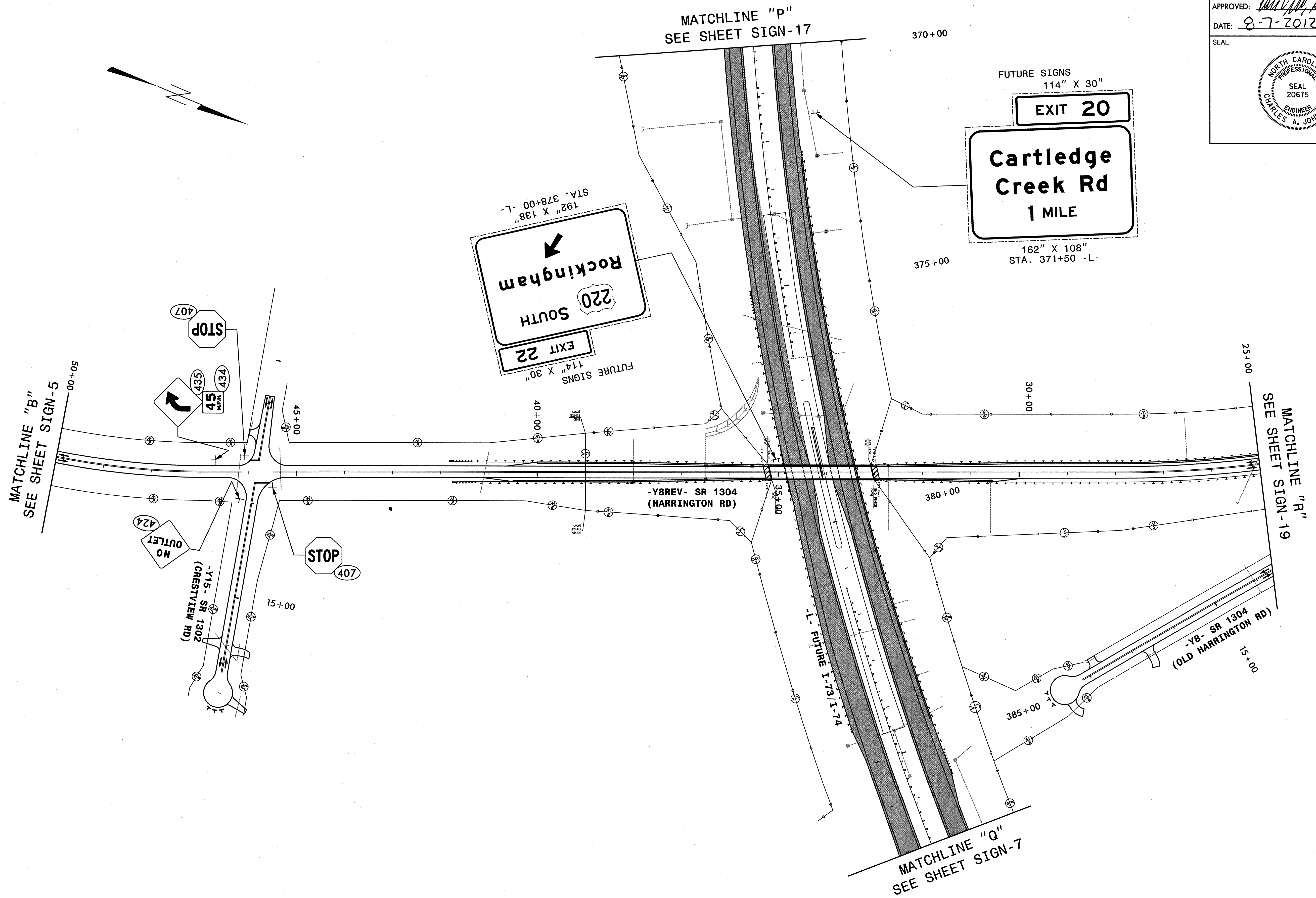
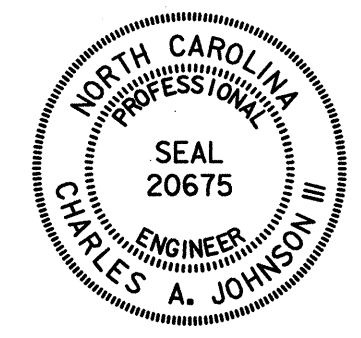

NOTE:
 REMOVE AND DISPOSE OF EXISTING SIGNS WITHIN PROJECT LIMITS UNLESS OTHERWISE NOTED.
 ALL PROPOSED SIGNS SEE NOTE 5 UNLESS OTHERWISE NOTED.

HNTB HNTB NORTH CAROLINA, P.C.
 343 E. Six Forks Road, Suite 200
 Raleigh, North Carolina 27609
 NC License No: C-1554

PROPOSED SIGNS
STA. 370+00 TO 387+00 -L-

TIP NO. R-3421C	SHEET NO. SIGN-19
APPROVED: <i>[Signature]</i>	
DATE: 8-7-2012	
SEAL	
	

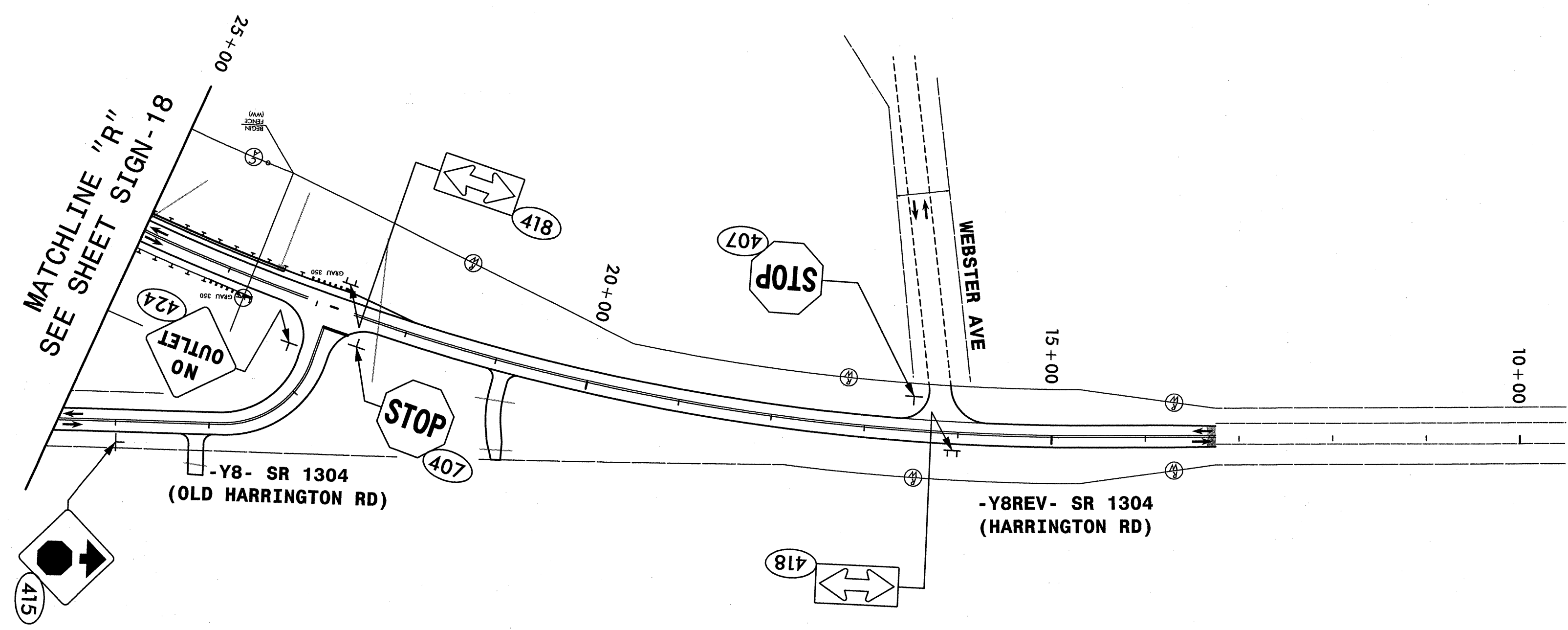
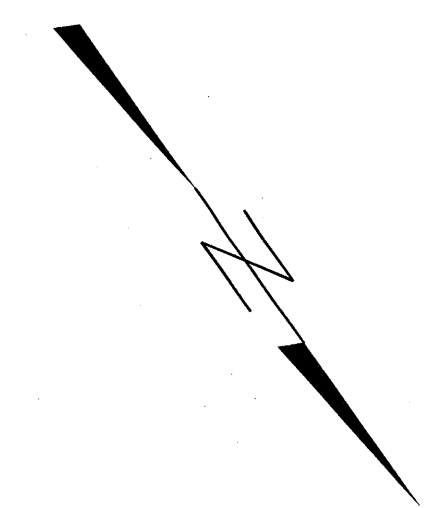

NOTE:
 REMOVE AND DISPOSE OF EXISTING SIGNS WITHIN PROJECT LIMITS UNLESS OTHERWISE NOTED.
 ALL PROPOSED SIGNS SEE NOTE 5 UNLESS OTHERWISE NOTED.

HNTB HNTB NORTH CAROLINA, P.C.
 343 E. Six Forks Road, Suite 200
 Raleigh, North Carolina 27609
 NC License No: C-1554

PROPOSED SIGNS
STA. 10+00 TO 25+00 -Y8REV-