

T.I.P.: R-2633BA

CONTRACT: C203199

STATE OF NORTH CAROLINA  
DEPARTMENT OF TRANSPORTATION

**PAVEMENT MARKING PLAN**  
**BRUNSWICK COUNTY**

US 17 (WILMINGTON BYPASS) FROM US 1476  
EAST OF MALMO IN BRUNSWICK COUNTY TO  
SR 1430 (CEDAR HILL ROAD)

TIP NO. R-2633BA	SHEET NO. PMP-1
APPROVED: <i>Steve Miller</i>	
DATE: 9-19-13	
SEAL	
	

**PAVEMENT MARKING SCHEDULE**

SYMBOL	DESCRIPTION
	<u>POLYUREA (12") Highly Reflective Elements</u>
VS	WHITE GORELINE
VT	WHITE SOLID LANE LINE
	<u>THERMOPLASTIC (24", 120 MILS) Standard Glass Beads</u>
T2	WHITE STOPBAR
	<u>POLYUREA (4") Highly Reflective Elements</u>
VA	WHITE EDGELINE
VD	3 FT. - 9 FT. /SP WHITE MINISKIP
VE	WHITE SOLID LANE LINE
VI	YELLOW DOUBLE CENTER
	<u>THERMOPLASTIC (4", 120 MILS) Standard Glass Beads</u>
T8	2 FT. - 6 FT. /SP WHITE MINISKIP
T9	3 FT. - 9 FT. /SP WHITE MINISKIP
TE	WHITE SOLID LANE LINE
TF	10 FT. YELLOW SKIP
TH	YELLOW SINGLE CENTER
TI	YELLOW DOUBLE CENTER
	<u>THERMOPLASTIC (4", 90 MILS) Standard Glass Beads</u>
TA	WHITE EDGELINE
	<u>POLYUREA (6") Highly Reflective Elements</u>
V6	WHITE EDGELINE
V7	YELLOW EDGELINE
VJ	10 FT. WHITE SKIP
VK	3 FT. - 9 FT. /SP WHITE MINISKIP
VL	WHITE SOLID LANE LINE
	<u>THERMOPLASTIC (8", 90 MILS) Standard Glass Beads</u>
TP	YELLOW DIAGONAL
	<u>THERMOPLASTIC PAVEMENT MARKING SYMBOLS (90 MILS) Standard Glass Beads</u>
UA	LEFT TURN ARROW
UB	RIGHT TURN ARROW
UP	MERGE ARROW
	<u>PERMANENT RAISED PAVEMENT MARKERS</u>
MB	CRYSTAL & RED
	<u>SNOWPLOWABLE RAISED PAVEMENT MARKERS</u>
ME	YELLOW & YELLOW

**ROADWAY STANDARD DRAWING**

THE FOLLOWING ROADWAY STANDARDS AS APPEAR IN "ROADWAY STANDARD DRAWINGS" - PROJECT SERVICES UNIT - N.C. DEPARTMENT OF TRANSPORTATION - RALEIGH, N.C., DATED JANUARY 2012 ARE APPLICABLE TO THIS PROJECT AND BY REFERENCE HEREBY ARE CONSIDERED A PART OF THESE PLANS:

STD. NO.	TITLE
1205.01	PAVEMENT MARKINGS - LINE TYPES AND OFFSETS
1205.02	PAVEMENT MARKINGS - TWO-LANE AND MULTILANE ROADWAYS
1205.03	PAVEMENT MARKINGS - EXIT AND ENTRANCE RAMP
1205.04	PAVEMENT MARKINGS - INTERSECTIONS
1205.05	PAVEMENT MARKINGS - TURN LANES
1205.08	PAVEMENT MARKINGS - SYMBOLS AND WORD MESSAGES
1205.09	PAVEMENT MARKINGS - PAINTED ISLANDS
1205.12	PAVEMENT MARKINGS - BRIDGES
1250.01	RAISED PAVEMENT MARKERS - INSTALLATION SPACING
1251.01	RAISED PAVEMENT MARKERS - PERMANENT AND TEMPORARY
1253.01	RAISED PAVEMENT MARKERS - SNOWPLOWABLE
1261.01	GUARDRAIL AND BARRIER DELINEATORS - INSTALLATION SPACING
1261.02	GUARDRAIL AND BARRIER DELINEATORS - TYPES AND MOUNTING
1262.01	GUARDRAIL END DELINEATION

**GENERAL NOTES**

THE FOLLOWING GENERAL NOTES APPLY AT ALL TIMES FOR THE DURATION OF THE CONSTRUCTION PROJECT, EXCEPT WHEN OTHERWISE NOTED IN THE PLAN, OR DIRECTED BY THE ENGINEER.

- A) INSTALL PAVEMENT MARKINGS AND PAVEMENT MARKERS ON THE FINAL SURFACE AS FOLLOWS:

ROAD NAME	MARKING	MARKER
-Y7-, -Y8-, -Y9- & ALL SERVICE ROADS	THERMOPLASTIC	RAISED SNOWPLOWABLE
-L-, -LREV-, RAMPS, LOOPS & BRIDGES	POLYUREA	SNOWPLOWABLE
- B) TIE PROPOSED PAVEMENT MARKING LINES TO EXISTING PAVEMENT MARKING LINES.
- C) REMOVE/REPLACE ANY CONFLICTING/DAMAGED PAVEMENT MARKINGS AND MARKERS.
- D) PASSING ZONES WILL BE DETERMINED IN THE FIELD AND MUST BE APPROVED BY THE ENGINEER.
- E) STOP BAR LOCATION AT NON-SIGNALIZED INTERSECTIONS MAY BE ADJUSTED AS DIRECTED BY THE ENGINEER.
- F) UNLESS OTHERWISE SPECIFIED, HEATED-IN-PLACE THERMOPLASTIC MAY BE USED IN LIEU OF EXTRUDED THERMOPLASTIC FOR STOP BARS, SYMBOLS, CHARACTERS AND DIAGONALS. IF HEATED-IN-PLACE IS USED, IT SHALL BE PAID FOR USING THE EXTRUDED THERMOPLASTIC PAY ITEM.
- G) MARKERS SHALL BE INSTALLED ACCORDING TO THE NCDOT ROADWAY STANDARD DRAWING 1250.01.

**INDEX**

SHEET NO.	DESCRIPTION
PMP-1	PAVEMENT MARKING PLAN TITLE AND SCHEDULE SHEET
PMP-1A	PAVEMENT MARKING OVERVIEW DETAIL
PMP-2-17	PAVEMENT MARKING DETAILS

PLAN REVIEWED BY: N.C.D.O.T. SIGNING AND DELINEATION UNIT

AYMAN ALOUDWAH, P.E. SIGNING & DELINEATION REGIONAL ENGINEER

MITCH EATON SIGNING & DELINEATION PROJECT DESIGN ENGINEER

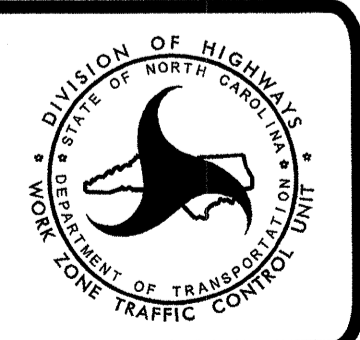

PLAN PREPARED BY: SEPI ENGINEERING & CONSTRUCTION

CLIFF LAWSON, EI PROJECT ANALYST

STEVE MILLER, PE TRANSPORTATION ENGINEER



C:\P\2013\20130919\20130919.DWG

TIP NO. R-2633BA	SHEET NO. PMP-1A
APPROVED: <i>See Mill</i>	
DATE: 5-3-13	
SEAL	

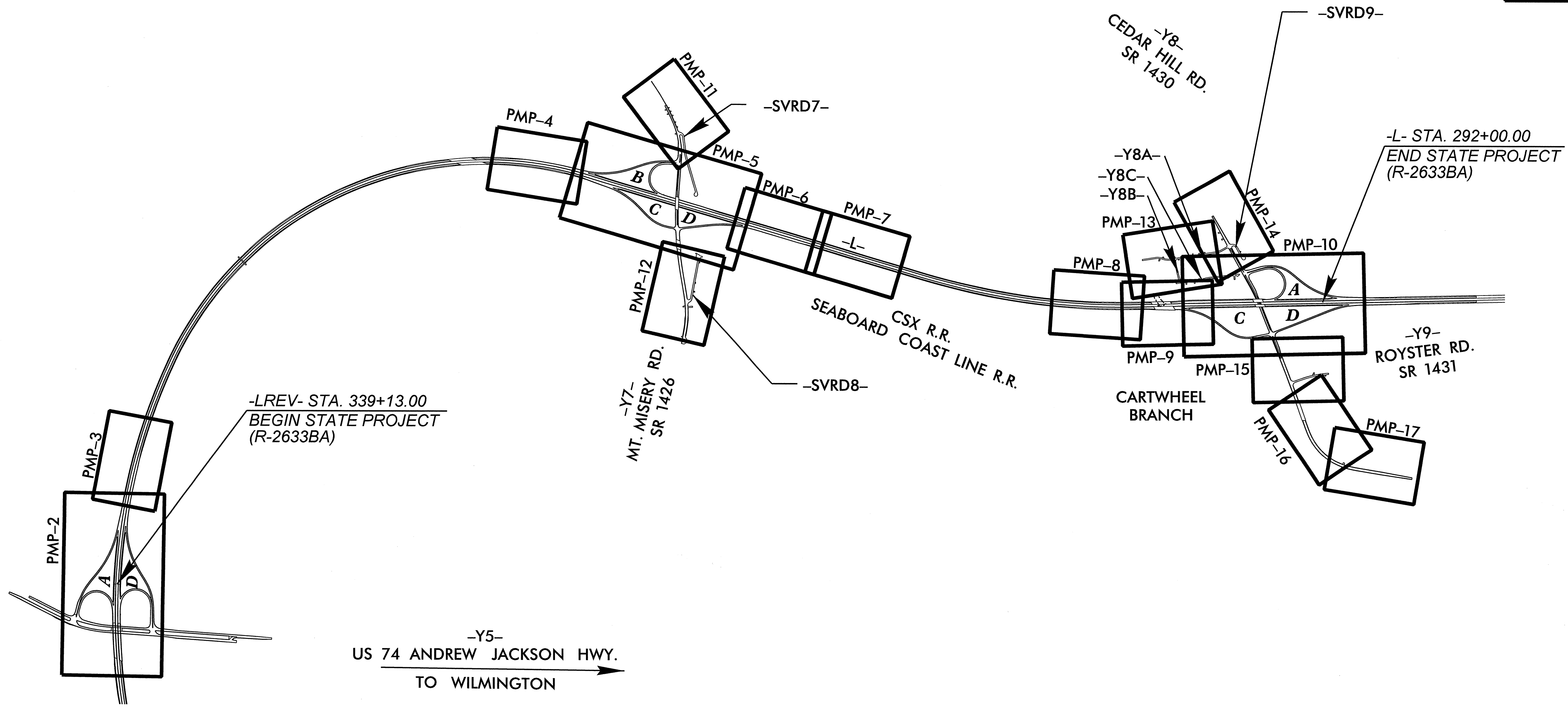

NAD 83/95 • NC GRID

\$\$\$SYTIME\$\$\$\$\$  
 \$\$\$DGN\$\$\$\$\$  
 \$\$\$USERNAME\$\$\$\$\$

**SEPI**  
 ENGINEERING & CONSTRUCTION  
1025 Wade Avenue  
 Raleigh, NC 27605  
 Tel: 919-789-9977  
 Fax: 919-789-9591  
 License: C-2197

**PAVEMENT MARKING DETAIL**

TIP NO. R-2633BA	SHEET NO. PMP-2
APPROVED: <i>Stu Hill</i>	
DATE: 5-3-13	
SEAL	

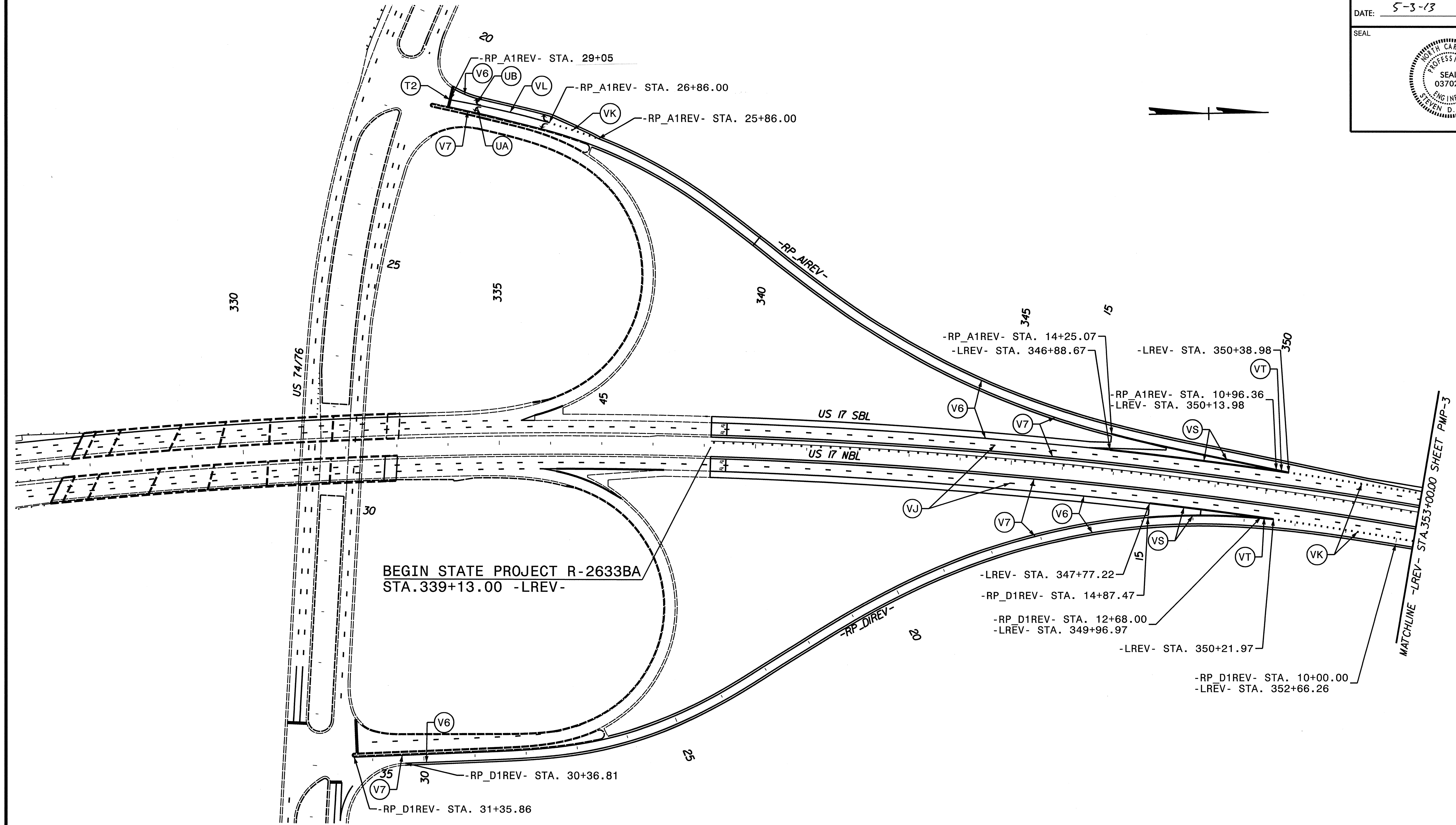

\$\$\$\$\$SYTIME\$\$\$\$\$  
 \$\$\$DDON\$\$\$\$\$  
 \$\$\$USERNAM\$\$\$\$\$

**SEPI** ENGINEERING & CONSTRUCTION  
 1025 Wade Avenue  
 Raleigh, NC 27605  
 Tel: 919-789-9977  
 Fax: 919-789-9591  
 License: C-2197

**PAVEMENT MARKING DETAIL**

TIP NO. R-2633BA	SHEET NO. PMP-3
APPROVED: <i>St. Mill</i>	
DATE: 5-3-13	
SEAL	

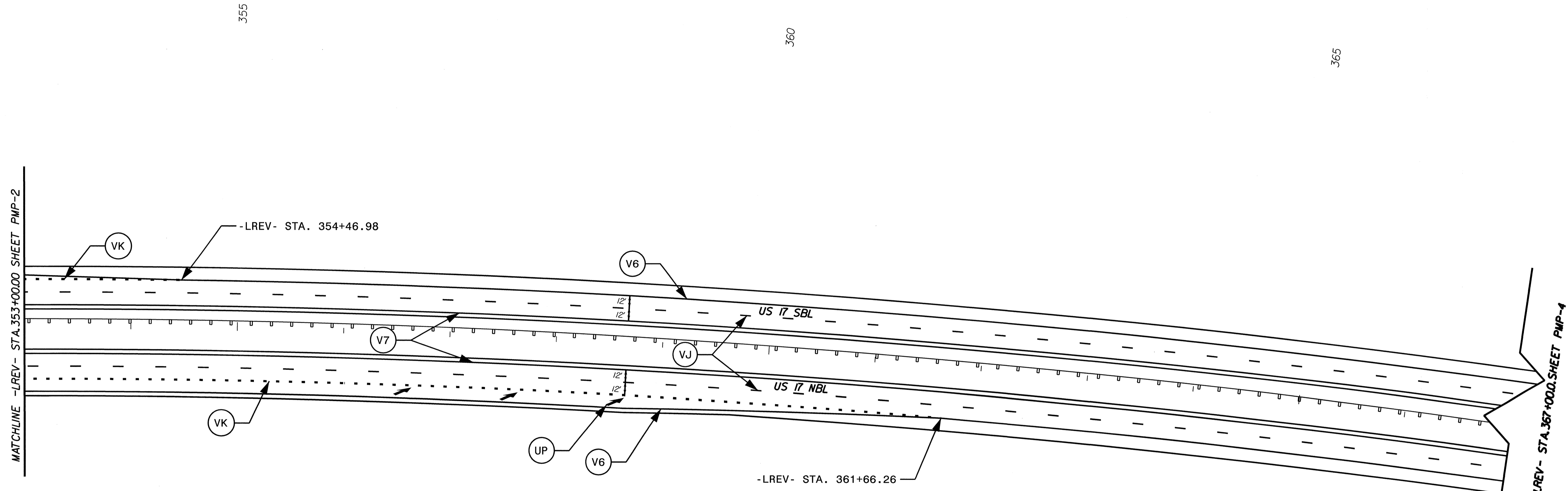

NOTE:  
 -LREV- Sta. 375+54.20 BK =  
 -L- Sta. 83+54.50 AH

##### SYSTEM #####  
 ##### DDON #####  
 ##### USERNAME #####

**SEPI**  
 ENGINEERING & CONSTRUCTION

1025 Wade Avenue  
 Raleigh, NC 27605  
 Tel: 919-789-9977  
 Fax: 919-789-9591  
 License: C-2187

**PAVEMENT MARKING DETAIL**



TIP NO. R-2633BA	SHEET NO. PMP-4
APPROVED: <i>Stu Miller</i>	
DATE: 5-3-13	
SEAL	

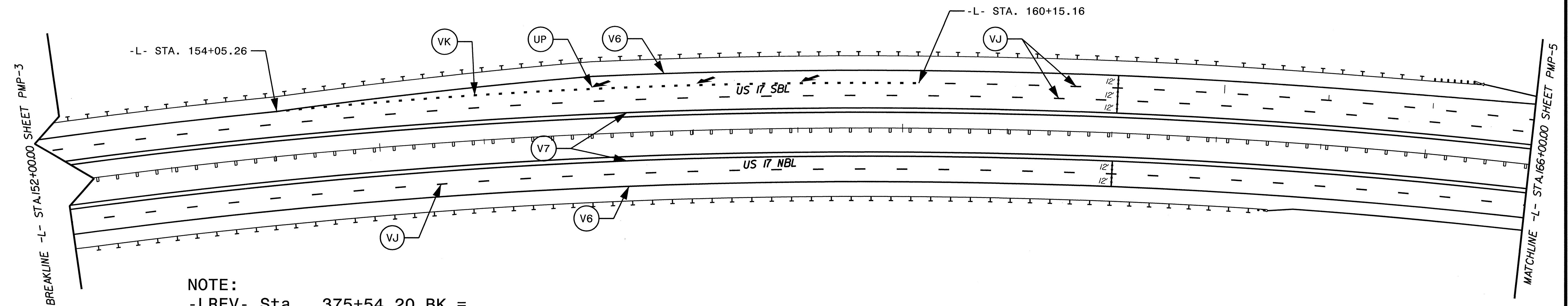

NOTE:  
 -LREV- Sta. 375+54.20 BK =  
 -L- Sta. 83+54.50 AH

\$\$\$\$\$SYTIME\$\$\$\$\$  
 \$\$\$\$\$\$DCN\$\$\$\$\$  
 \$\$\$\$\$\$USERNAM\$\$\$\$\$

**SEPI**  
 ENGINEERING & CONSTRUCTION  
 1025 Wade Avenue  
 Raleigh, NC 27605  
 Tel: 919-789-9977  
 Fax: 919-789-9591  
 License: C-2197

**PAVEMENT MARKING DETAIL**

TIP NO. R-2633BA	SHEET NO. PMP-5
APPROVED: <i>[Signature]</i>	
DATE: 5-3-13	
SEAL	

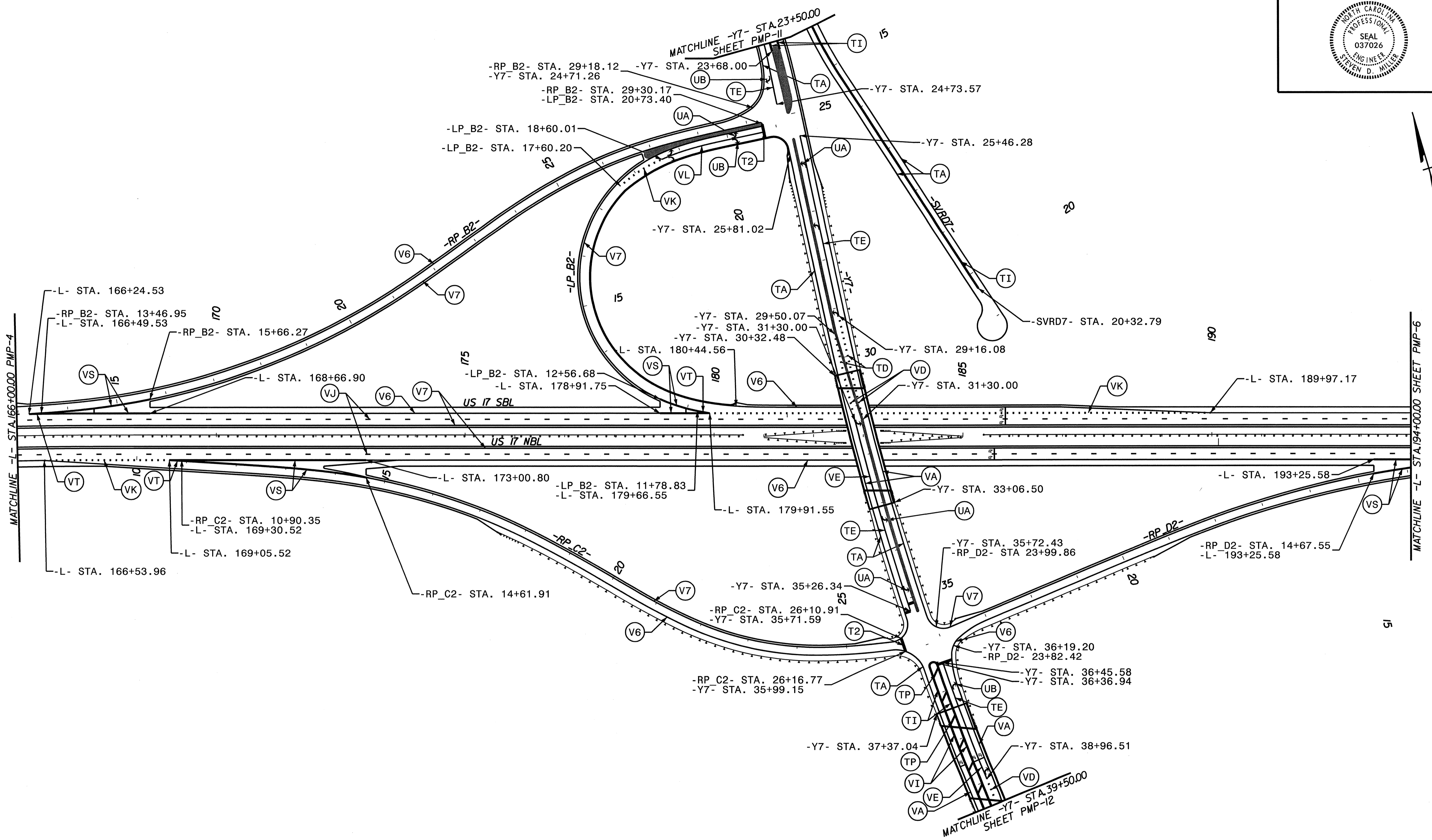

\$\$\$\$\$SYTIME\$\$\$\$\$  
 \$\$\$DDON\$\$\$\$\$  
 \$\$\$USERNAME\$\$\$\$\$

**SEPI** ENGINEERING & CONSTRUCTION  
 1025 Wade Avenue  
 Raleigh, NC 27605  
 Tel: 919-789-9977  
 Fax: 919-789-9591  
 License: C-2197

**PAVEMENT MARKING DETAIL**

TIP NO. R-2633BA	SHEET NO. PMP-6
APPROVED: <i>[Signature]</i>	
DATE: 5-3-13	
SEAL	

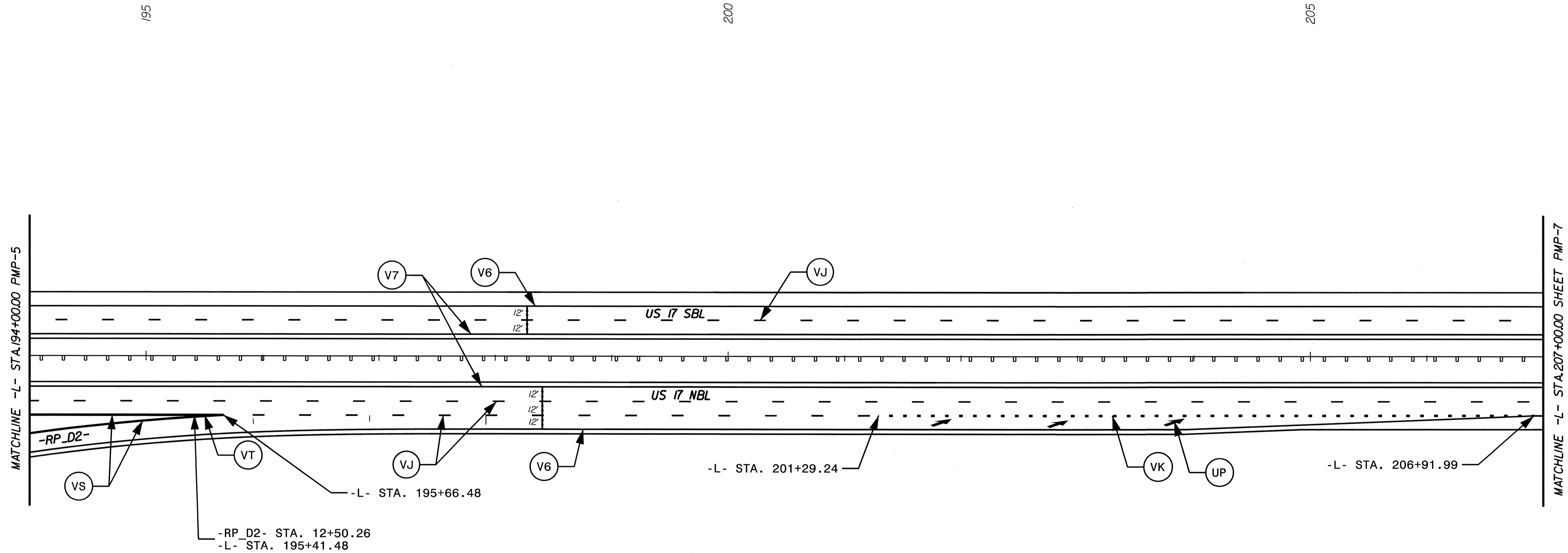
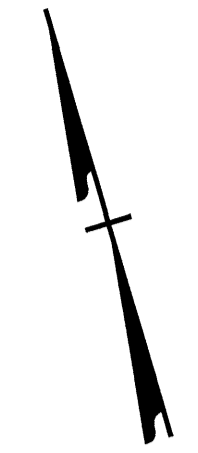

\$\$\$\$\$SYSTEM\$\$\$\$\$  
 \$\$\$\$DCN\$\$\$\$\$  
 \$\$\$USERNAM\$\$\$\$\$

**SEPI**  
 ENGINEERING & CONSTRUCTION  
 1025 Wade Avenue  
 Raleigh, NC 27605  
 Tel: 919-789-9977  
 Fax: 919-789-9591  
 License: C-2197

**PAVEMENT MARKING DETAIL**

TIP NO.	SHEET NO.
R - 2633BA	PMP - 7
APPROVED: <i>Steve Miller</i>	
DATE: <i>5-3-13</i>	

SEAL

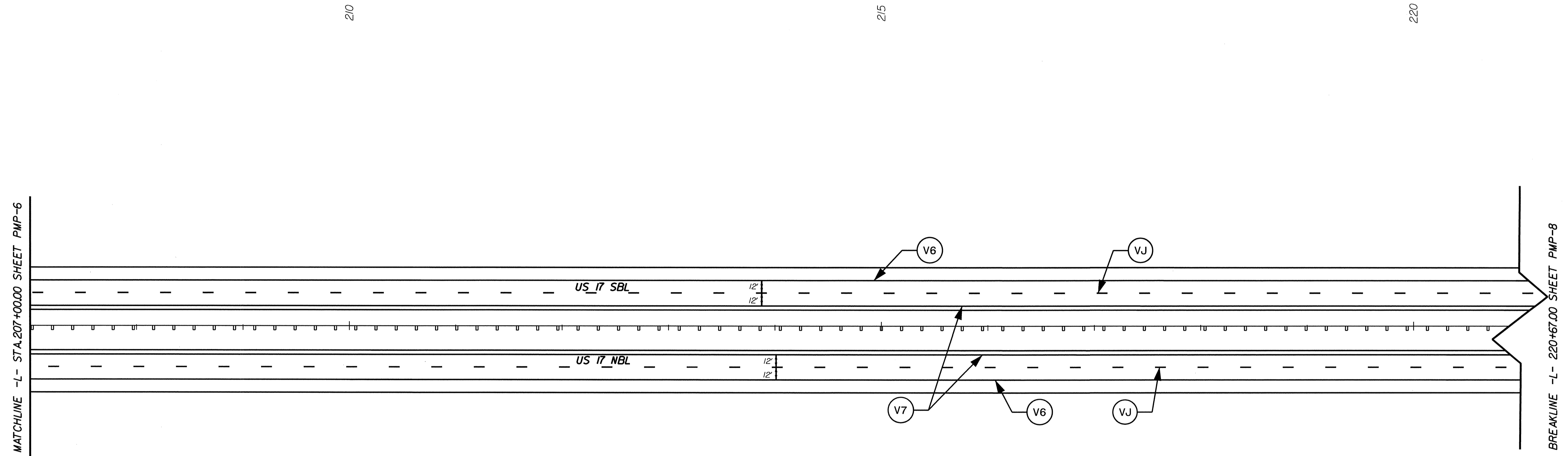
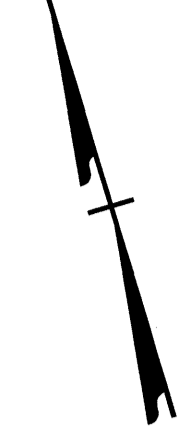
\*\*\*\*\*  
 \*\*\*SYTIME\*\*\*  
 \*\*\*ADDON\*\*\*  
 \*\*\*\$\*\*\*  
 \*\*\*\$\*\*\*  
 \*\*\*\$\*\*\*  
 \*\*\*\$\*\*\*  
 \*\*\*\$\*\*\*  
 \*\*\*\$\*\*\*  
 \*\*\*\*\*



1025 Wade Avenue  
 Raleigh, NC 27605  
 Tel: 919-789-8977  
 Fax: 919-789-9591  
 License: C-2197

## PAVEMENT MARKING DETAIL



TIP NO. R-2633BA	SHEET NO. PMP-8
APPROVED: <i>St. Miller</i>	
DATE: 5-3-13	
SEAL	

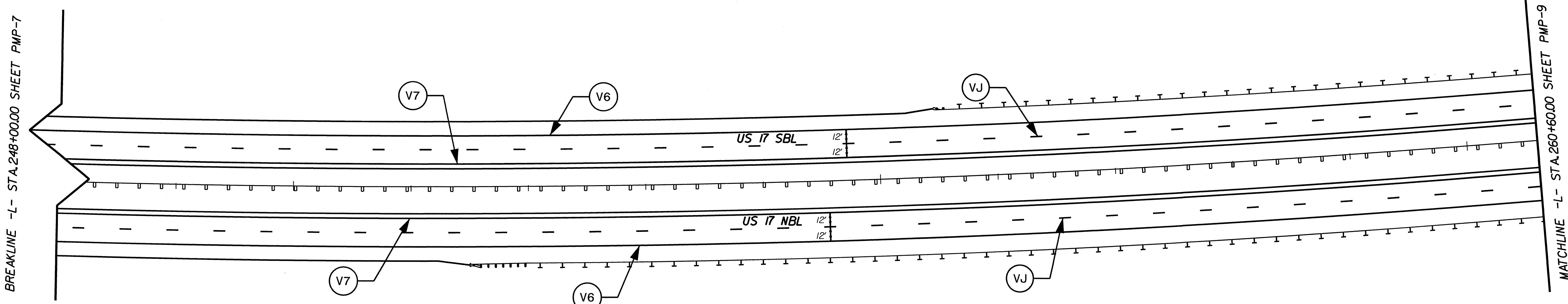

250

255

260



\$\$\$\$SYSTIME\$\$\$\$  
\$\$\$\$DCN\$\$\$\$  
\$\$\$\$USERNAM\$\$\$\$

**SEPI**  
ENGINEERING & CONSTRUCTION

1025 Wade Avenue  
Raleigh, NC 27605  
Tel: 919-789-9977  
Fax: 919-789-9531  
License: C-2197

**PAVEMENT MARKING DETAIL**

TIP NO. R-2633BA	SHEET NO. PMP-9
APPROVED: <i>Stc Mill</i>	
DATE: 5-3-13	
SEAL	

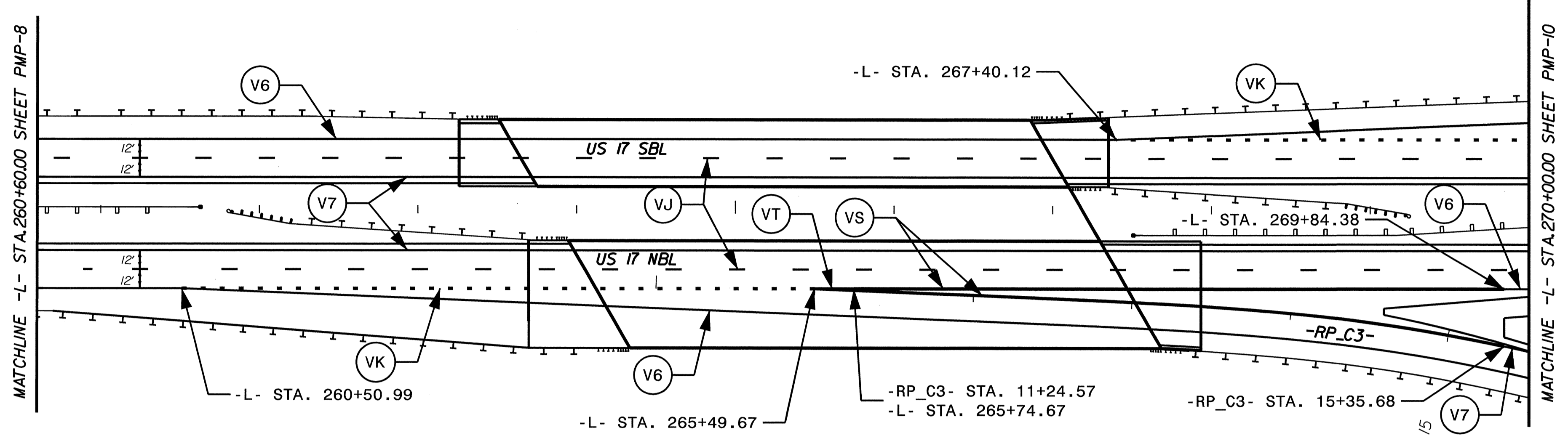

\$\$\$\$\$SYTIME\$\$\$\$\$  
 \$\$\$\$\$\$DON\$\$\$\$\$  
 \$\$\$\$\$\$USERNAME\$\$\$\$\$

**SEPI**  
 ENGINEERING & CONSTRUCTION  
 1025 Wade Avenue  
 Raleigh, NC 27605  
 Tel: 919-789-9977  
 Fax: 919-789-9591  
 License: C-2197

**PAVEMENT MARKING DETAIL**



TIP NO. R-2633BA	SHEET NO. PMP-11
APPROVED: <i>Stu Miller</i>	
DATE: 5-3-13	
SEAL	

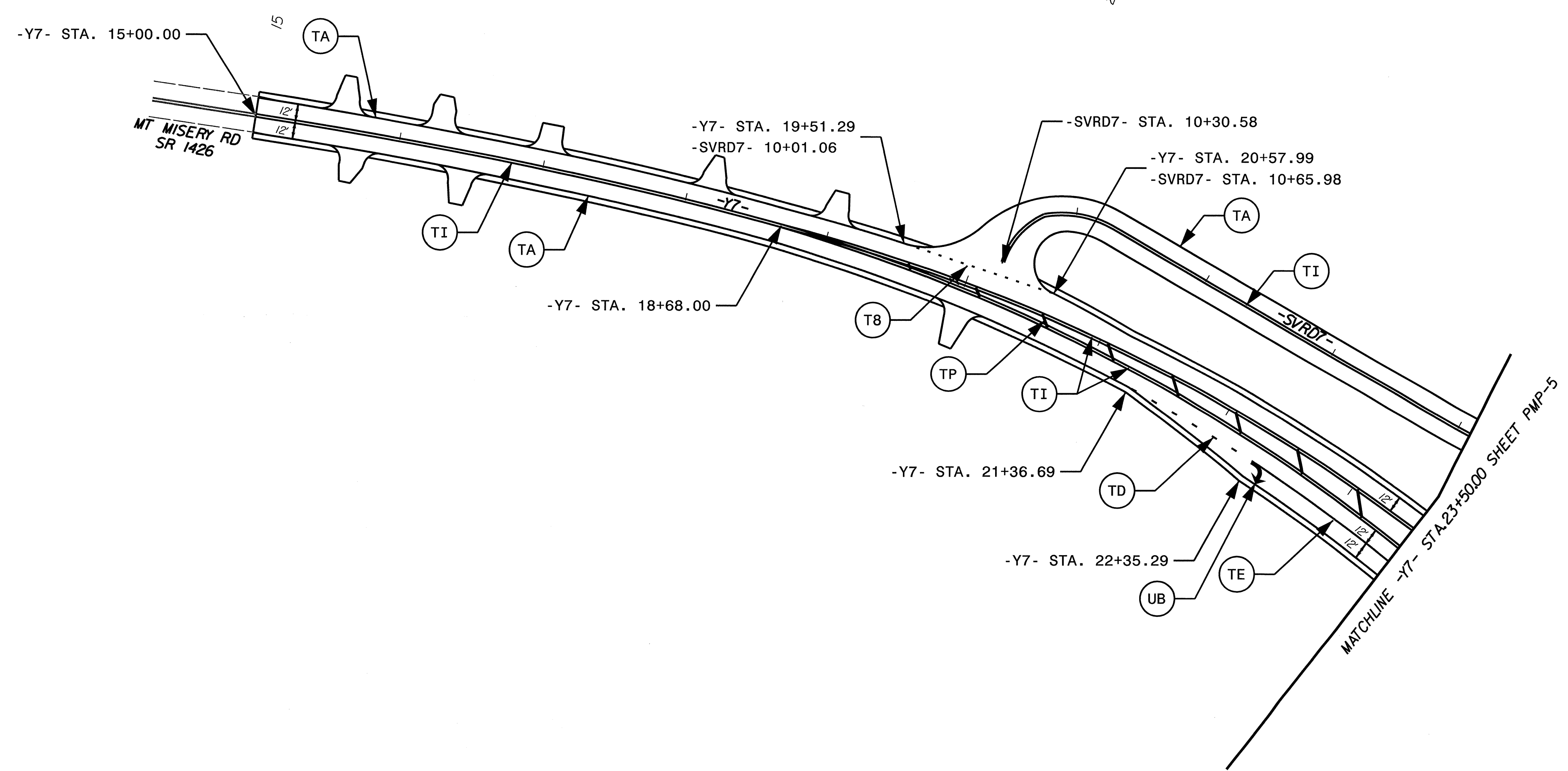
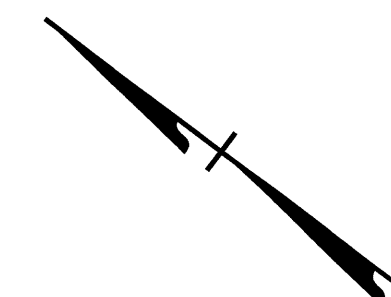

\$\$\$\$\$SYTIME\$\$\$\$\$  
 \$\$\$DCN\$\$\$  
 \$\$\$BUSERNAME\$\$\$

**SEPI**  
 ENGINEERING & CONSTRUCTION  
 1025 Wade Avenue  
 Raleigh, NC 27605  
 Tel: 919-789-9977  
 Fax: 919-789-9591  
 License: C-2197

**PAVEMENT MARKING DETAIL**

TIP NO.	SHEET NO.
R-2633BA	PMP-12
APPROVED: <i>See Add</i>	
DATE: 5-3-13	
SEAL	

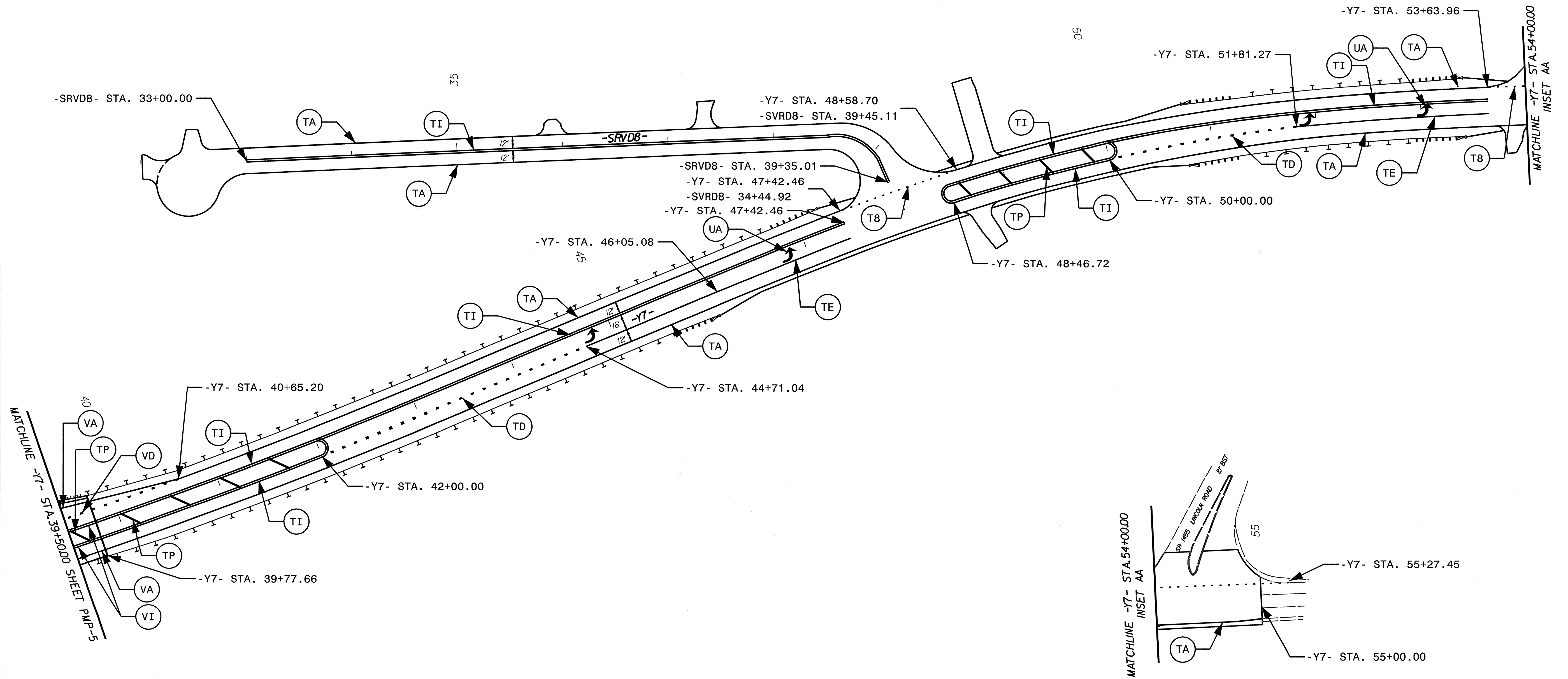

\$\$\$\$\$SYTIME\$\$\$\$\$  
 \$\$\$CDON\$\$\$\$\$  
 \$\$\$USERNAME\$\$\$\$\$

**SEPI**  
 ENGINEERING & CONSTRUCTION

1025 Wade Avenue  
 Raleigh, NC 27605  
 Tel: 919-789-9977  
 Fax: 919-789-9591  
 License: C-2197

**PAVEMENT MARKING DETAIL**



TIP NO. R-2633BA	SHEET NO. PMP-13
APPROVED: <i>Se Miller</i>	
DATE: 5-3-13	
SEAL	

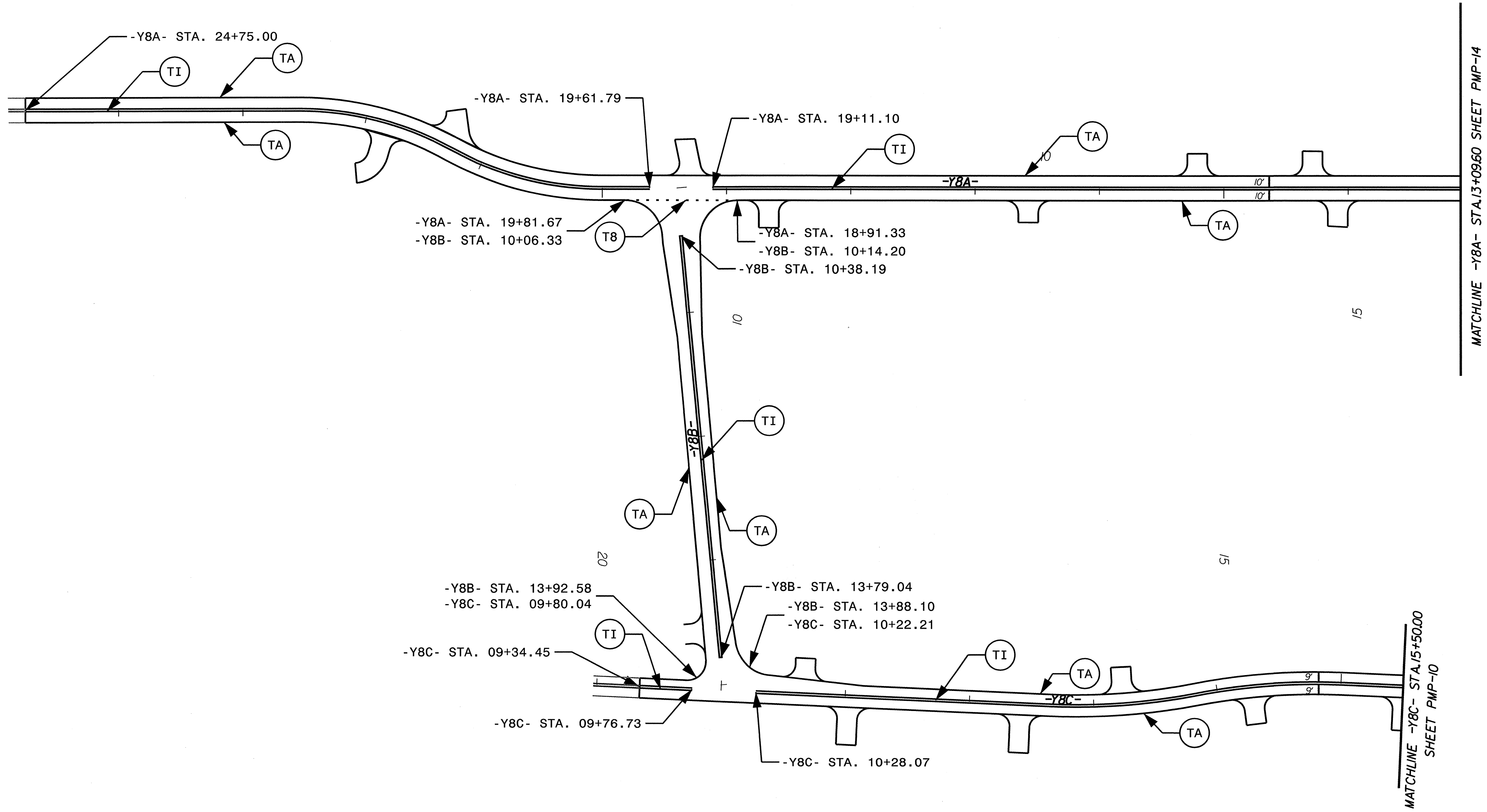

25

\$\$\$\$\$SYSTIME\$\$\$\$\$  
 \$\$\$LSDON\$\$\$\$\$  
 \$\$\$SERNAME\$\$\$

**SEPI**  
 ENGINEERING & CONSTRUCTION

1025 Wade Avenue  
 Raleigh, NC 27605  
 Tel: 919-789-9977  
 Fax: 919-789-9591  
 License: C-2197

**PAVEMENT MARKING DETAIL**

TIP NO.	SHEET NO.
R-2633BA	PMP-14
APPROVED: <i>St. Miller</i>	
DATE: 5-3-13	
SEAL	

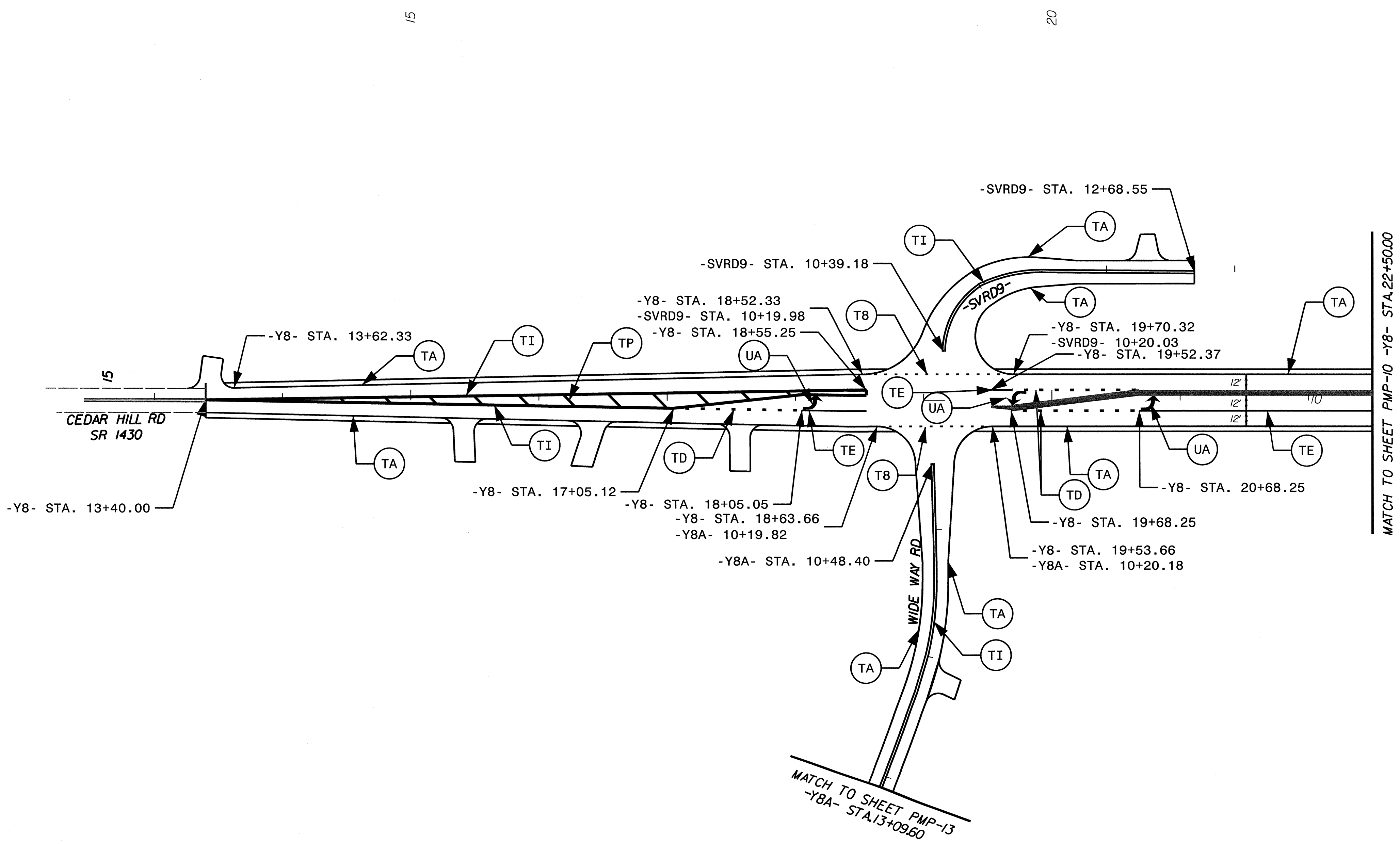

\$\$\$\$\$SYTIME\$\$\$\$\$  
 \$\$\$SYTIME\$\$\$\$\$  
 \$\$\$SYTIME\$\$\$\$\$  
 \$\$\$SYTIME\$\$\$\$\$  
 \$\$\$SYTIME\$\$\$\$\$  
 \$\$\$SYTIME\$\$\$\$\$  
 \$\$\$SYTIME\$\$\$\$\$  
 \$\$\$SYTIME\$\$\$\$\$  
 \$\$\$SYTIME\$\$\$\$\$  
 \$\$\$SYTIME\$\$\$\$\$  
 \$\$\$SYTIME\$\$\$\$\$

**SEPI** ENGINEERING & CONSTRUCTION  
 1025 Wade Avenue  
 Raleigh, NC 27605  
 Tel: 919-789-9977  
 Fax: 919-789-9581  
 License: C-2197

**PAVEMENT MARKING DETAIL**

TIP NO.	SHEET NO.
R-2633BA	PMP-15
APPROVED: <i>Se Miller</i>	
DATE: 5-3-13	
SEAL	

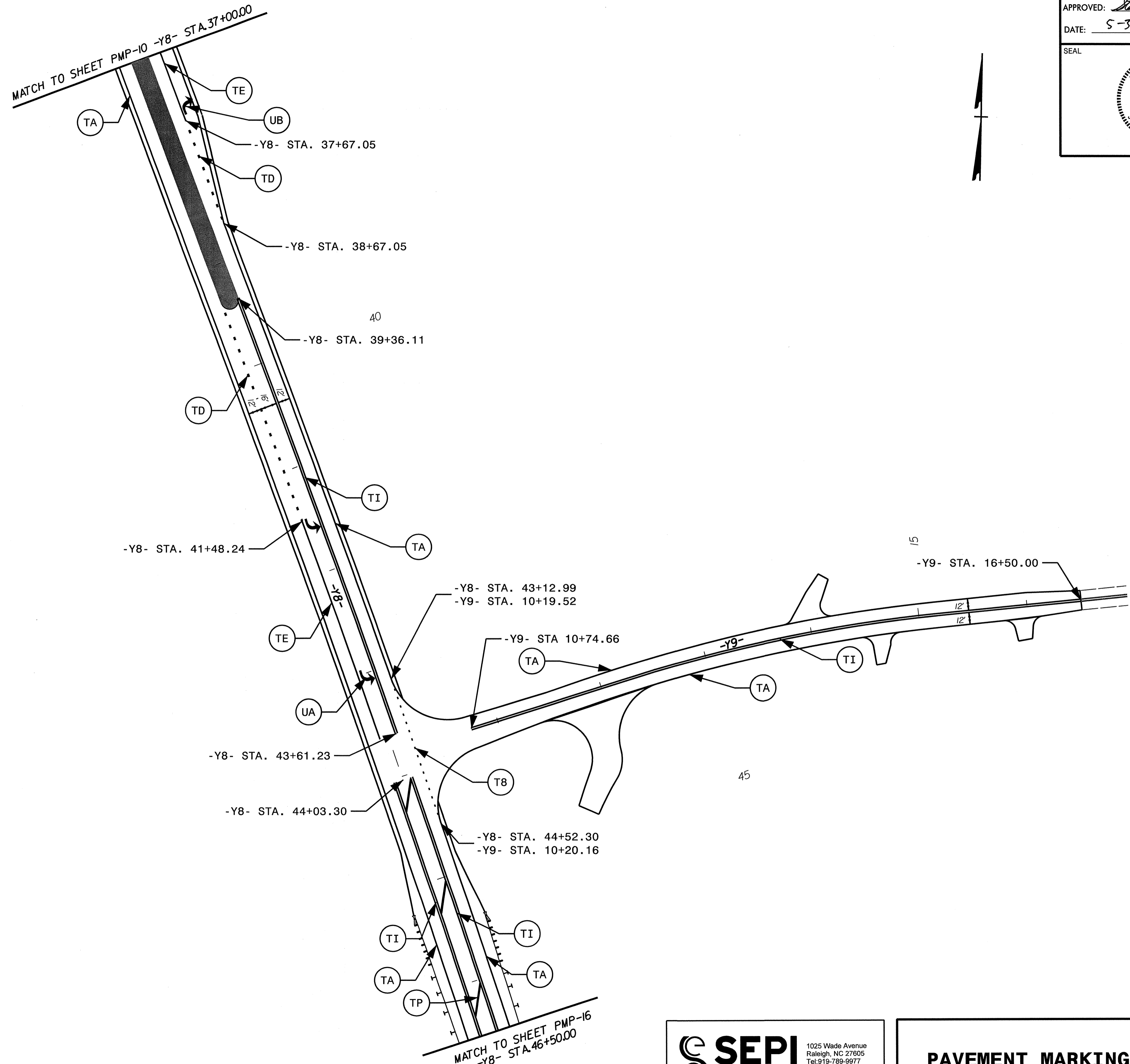

#####  
 SYSTEMS  
 #####

**SEPI**  
 ENGINEERING & CONSTRUCTION  
 1025 Wade Avenue  
 Raleigh, NC 27605  
 Tel: 919-789-9977  
 Fax: 919-789-9591  
 License: C-2197

**PAVEMENT MARKING DETAIL**

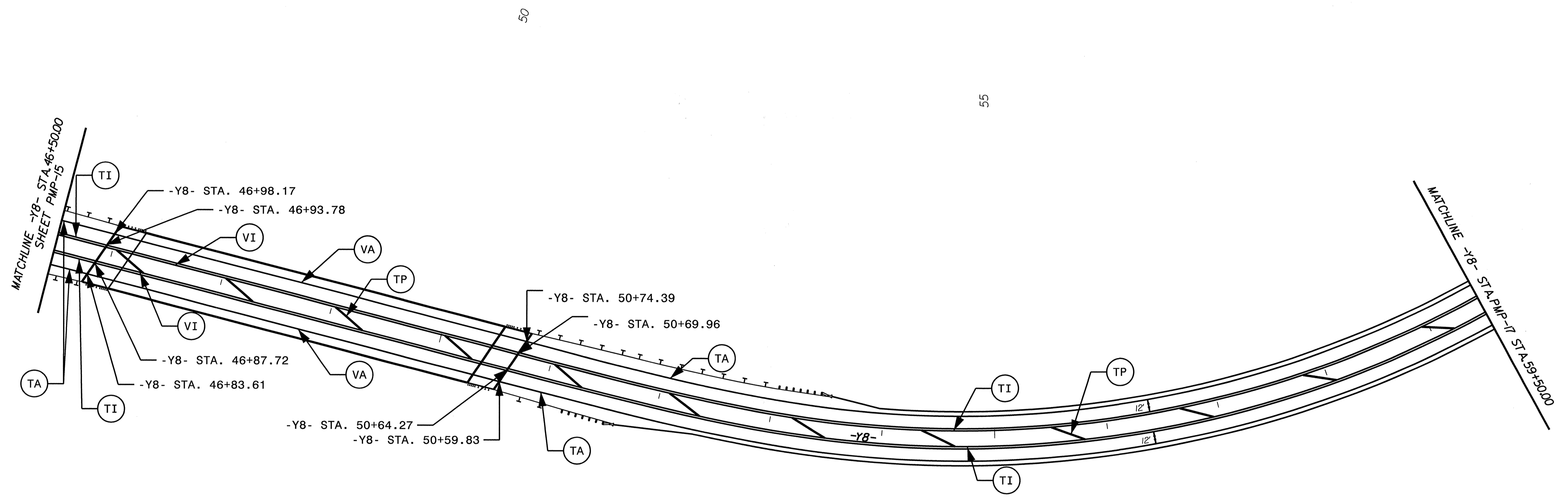
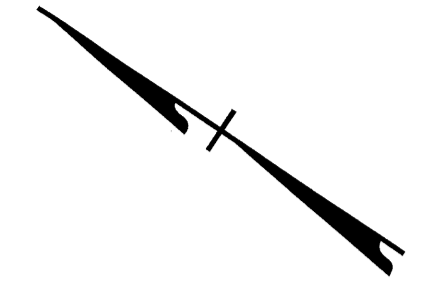
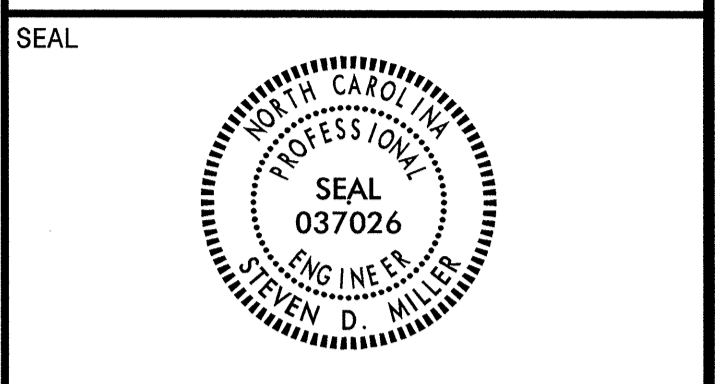

\$\$\$\$\$SYTIME\$\$\$\$\$  
 \$\$\$SDON\$\$\$\$\$  
 \$\$\$USERNAME\$\$\$\$\$

**SEPI**  
 ENGINEERING & CONSTRUCTION

1025 Wade Avenue  
 Raleigh, NC 27605  
 Tel: 919-789-9977  
 Fax: 919-789-9591  
 License: C-2197

**PAVEMENT MARKING DETAIL**

TIP NO. R-2633BA	SHEET NO. PMP-17
APPROVED: <i>Steve Miller</i>	
DATE: 5-3-13	
SEAL	

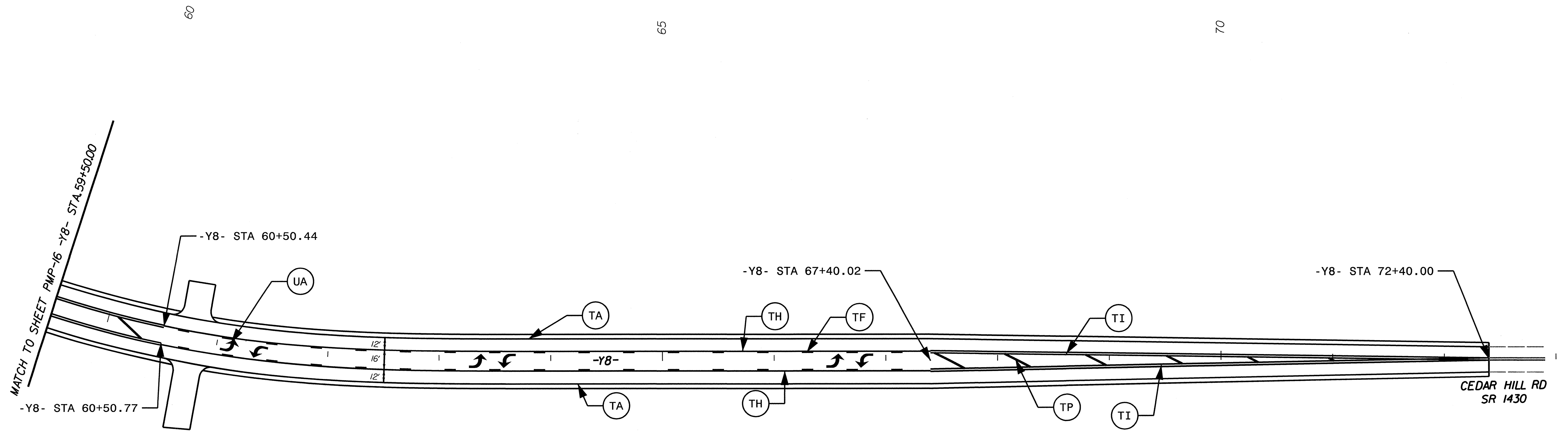

\$\$\$SYTIME\$\$\$  
 \$\$\$LDON\$\$\$  
 \$\$\$SUBSERNAME\$\$\$

**SEPI**  
 ENGINEERING & CONSTRUCTION  
 1025 Wade Avenue  
 Raleigh, NC 27605  
 Tel: 919-789-9977  
 Fax: 919-789-9591  
 License: C-2197

**PAVEMENT MARKING DETAIL**