

STATE OF NORTH CAROLINA  
DEPARTMENT OF TRANSPORTATION

PAVEMENT MARKING PLAN  
ALLEGHANY COUNTY

LOCATION: US 21 FROM SR 1100 (OKLAHOMA RD.) TO SR 1121 (PINE SWAMP RD.)

TIP NO. R-3101	SHEET NO. PMP-1
APPROVED: <i>[Signature]</i>	
DATE: 6/5/13	
SEAL	



T.I.P.: R-3101

ROADWAY STANDARD DRAWING

THE FOLLOWING ROADWAY STANDARDS AS APPEAR IN "ROADWAY STANDARD DRAWINGS" - PROJECT SERVICES UNIT - N.C. DEPARTMENT OF TRANSPORTATION - RALEIGH, N.C., DATED JANUARY 2012 ARE APPLICABLE TO THIS PROJECT AND BY REFERENCE HEREBY ARE CONSIDERED A PART OF THESE PLANS:

STD. NO.	TITLE
1205.01	PAVEMENT MARKINGS - LINE TYPES AND OFFSETS
1205.02	PAVEMENT MARKINGS - TWO-LANE AND MULTILANE ROADWAYS
1205.04	PAVEMENT MARKINGS - INTERSECTIONS
1205.05	PAVEMENT MARKINGS - TURN LANES
1205.08	PAVEMENT MARKINGS - SYMBOLS AND WORD MESSAGES
1205.09	PAVEMENT MARKINGS - PAINTED ISLANDS
1205.12	PAVEMENT MARKINGS - BRIDGES
1250.01	RAISED PAVEMENT MARKERS - INSTALLATION SPACING
1253.01	RAISED PAVEMENT MARKERS - SNOWPLOWABLE
1261.01	GUARDRAIL AND BARRIER DELINEATORS - INSTALLATION SPACING
1261.02	GUARDRAIL AND BARRIER DELINEATORS - TYPES AND MOUNTING
1262.01	GUARDRAIL END DELINEATION
1264.01	OBJECT MARKERS - TYPES
1264.02	OBJECT MARKERS - INSTALLATION

GENERAL NOTES

THE FOLLOWING GENERAL NOTES APPLY AT ALL TIMES FOR THE DURATION OF THE CONSTRUCTION PROJECT, EXCEPT WHEN OTHERWISE NOTED IN THE PLAN, OR DIRECTED BY THE ENGINEER.

- A) INSTALL PAVEMENT MARKINGS AND PAVEMENT MARKERS ON THE FINAL SURFACE AS FOLLOWS:

ROAD NAME	MARKING	MARKER
US 21	POLYUREA w/HIGHLY REFLECTIVE ELEMENTS	SNOWPLOWABLE

- B) TIE PROPOSED PAVEMENT MARKING LINES TO EXISTING PAVEMENT MARKING LINES.  
 C) REMOVE/REPLACE ANY CONFLICTING/DAMAGED PAVEMENT MARKINGS AND MARKERS.  
 D) PASSING ZONES WILL BE DETERMINED IN THE FIELD AND MUST BE APPROVED BY THE ENGINEER.  
 E) REMOVE ALL RESIDUE AND SURFACE LAITANCE BY ACCEPTABLE METHODS ON CONCRETE BRIDGE DECKS PRIOR TO PLACING POLYUREA w/HIGHLY REFLECTIVE ELEMENTS PAVEMENT MARKING MATERIAL.  
 F) STOPBAR LOCATIONS WILL BE DETERMINED IN THE FIELD AND MUST BE APPROVED BY THE ENGINEER.

PAVEMENT MARKING SCHEDULE

Symbol	Description
	FINAL PAVEMENT MARKINGS
	THEMOPLASTIC (24")
T2	White Stopbar
	POLYUREA (4")
V8	2ft - 6ft./SP White Miniskip
VA	White Edgeline
VD	3ft. - 9ft./SP White Miniskip
VE	White Lane Line
VF	Yellow Skip Right
VH	Yellow Single Center
VI	Double Yellow
	THEMOPLASTIC (8")
TP	Yellow Diagonals
	THEMOPLASTIC (90 MILS)
UA	Left Turn Arrow
UB	Right Turn Arrow
UD	Combo. Left/Straight Arrow
	MARKERS
	SNOWPLOWABLE
ME	Yellow & Yellow

Part 2 of 2

INDEX

SHEET NO.	DESCRIPTION
PMP-1	PAVEMENT MARKING PLAN TITLE AND SCHEDULE SHEET
PMP-2-7	PAVEMENT MARKING PLANS

PLAN PREPARED BY: N.C.D.O.T. SIGNING AND DELINEATION UNIT

Kelvin Jordan SIGNING & DELINEATION REGIONAL ENGINEER  
 Walter Johnson SIGNING & DELINEATION PROJECT DESIGN ENGINEER

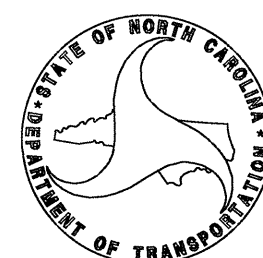

CONTRACT:

TIP NO. R-3101	SHEET NO. PMP-2
APPROVED: <i>RW</i>	
DATE: 6/5/13	
SEAL	
	

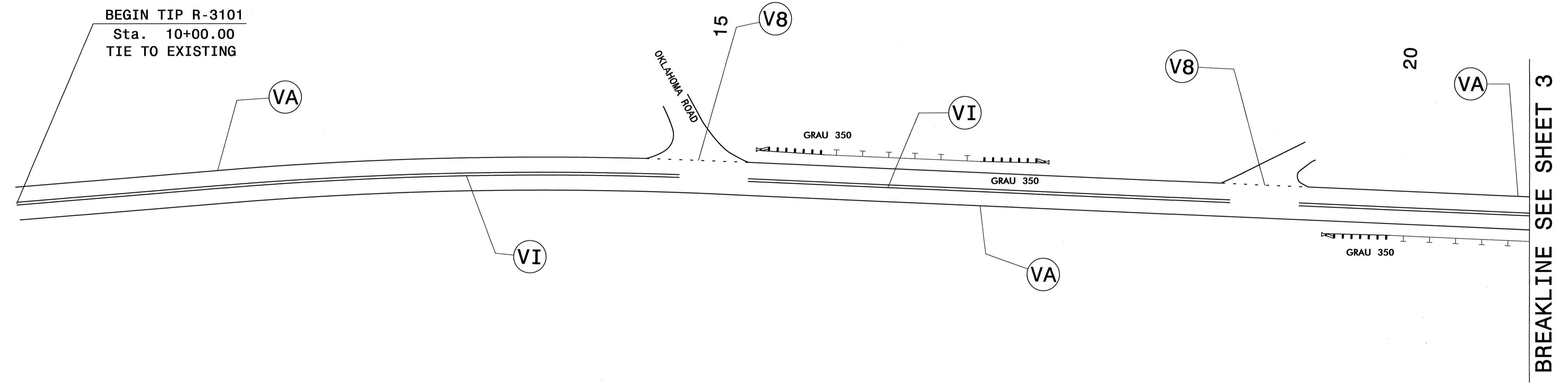
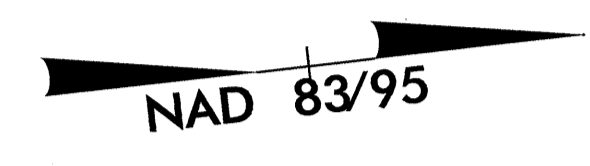

**PAVEMENT MARKINGS**

04-JUN-2013 07:40  
 R:\Traffic\Stations\CADD\PMR-3101\_Sign\_PMP\_Sheets.dgn  
 walter.johnson AT 1E247518

TIP NO. R-3101	SHEET NO. PMP-3
APPROVED: <i>[Signature]</i>	
DATE: 6/5/13	
SEAL	

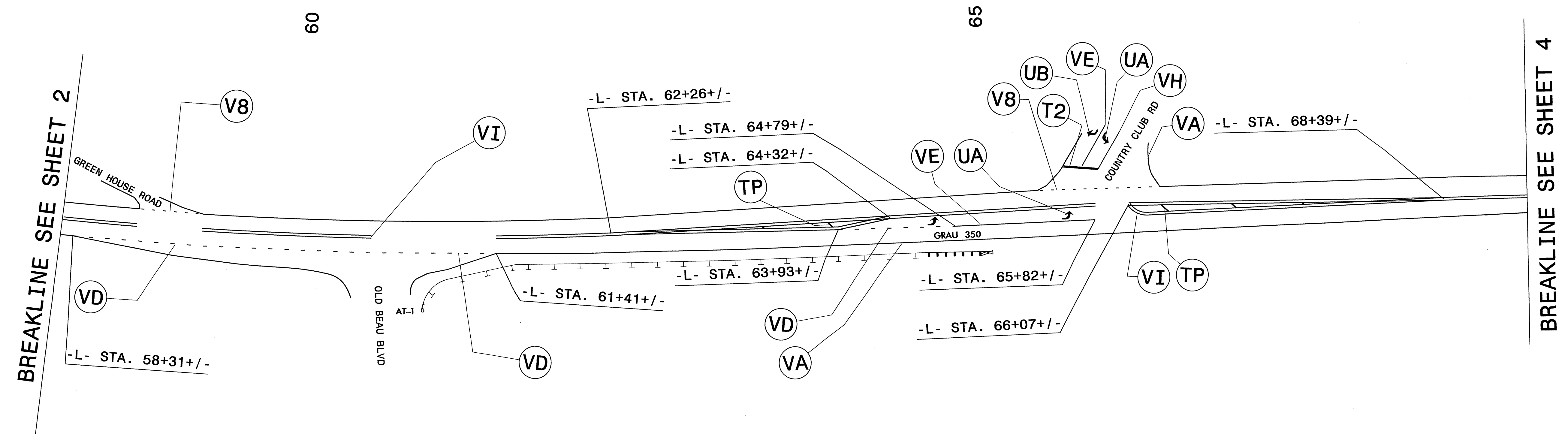
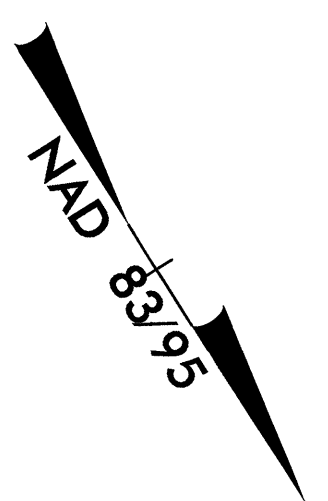

04 JUN 2013 07:12  
 R:\Projects\2013\3101\3101.dwg\ACADD\MPA-R-3101\_Sgn\_PMP\_Sheets.dgn  
 Walter Johnson

**PAVEMENT MARKINGS**

TIP NO. R-3101	SHEET NO. PMP-4
APPROVED: <i>[Signature]</i>	
DATE: 4/5/13	
SEAL	
	

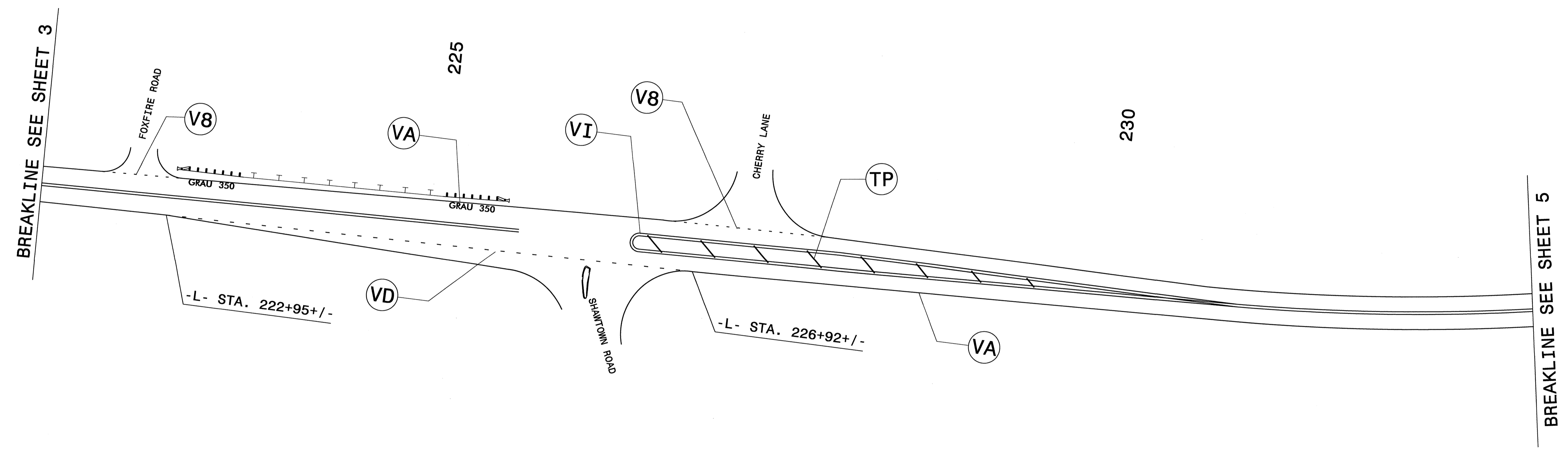
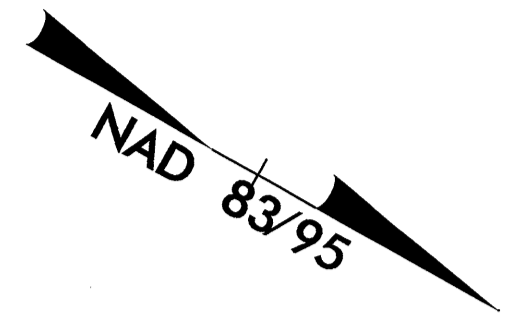

84 JUN 2013 07:50  
 C:\Users\wjohnson\Documents\CADD\PMR-3101-Sgn\_PMP\_Sheets.dgn  
 Walter Johnson AT 11:24:18

**PAVEMENT MARKINGS**

TIP NO. R-3101	SHEET NO. PMP-5
APPROVED: <i>RW</i>	
DATE: 6/5/13	
SEAL	

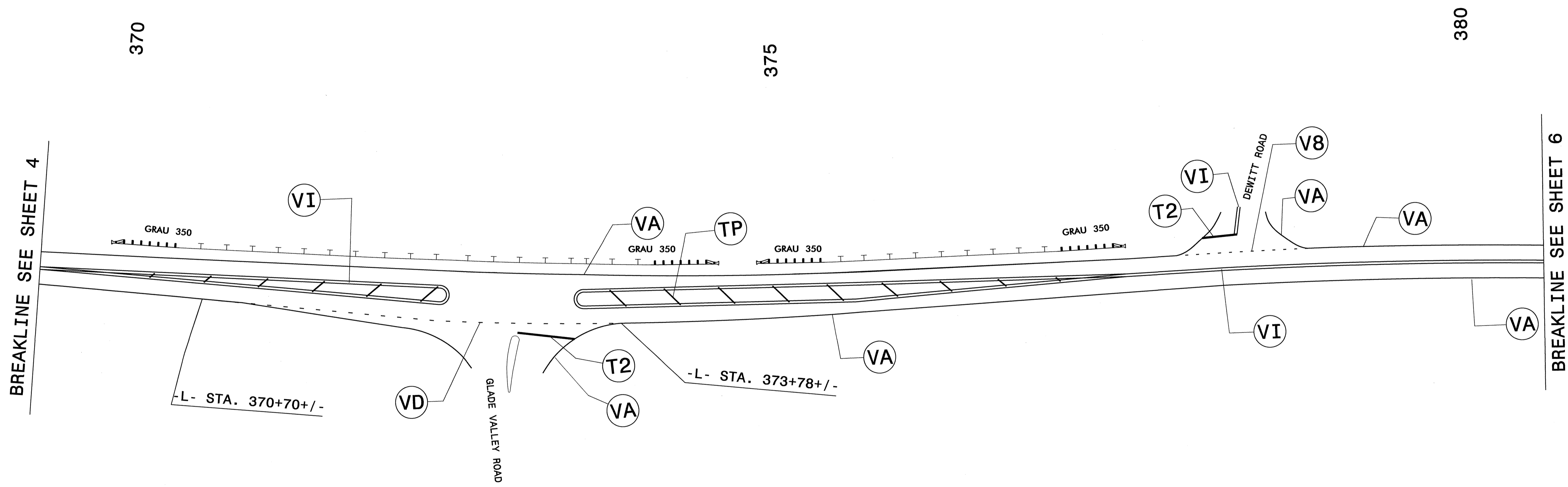
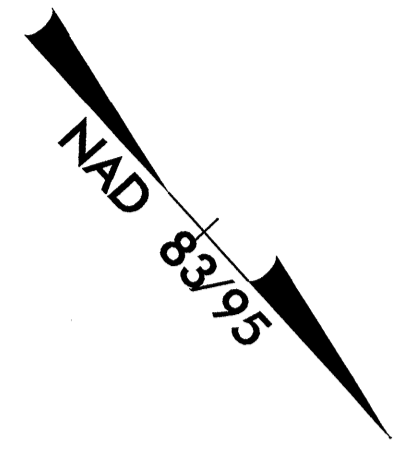

**PAVEMENT MARKINGS**

04 JUN 2015 07:16  
 C:\pmp\cadd\pmp\pmp-3101.sgn.pmp\_sheets.dgn  
 walter.johnson

TIP NO. R-3101	SHEET NO. PMP-6
APPROVED: <i>R. King</i>	
DATE: 6/5/13	
SEAL	

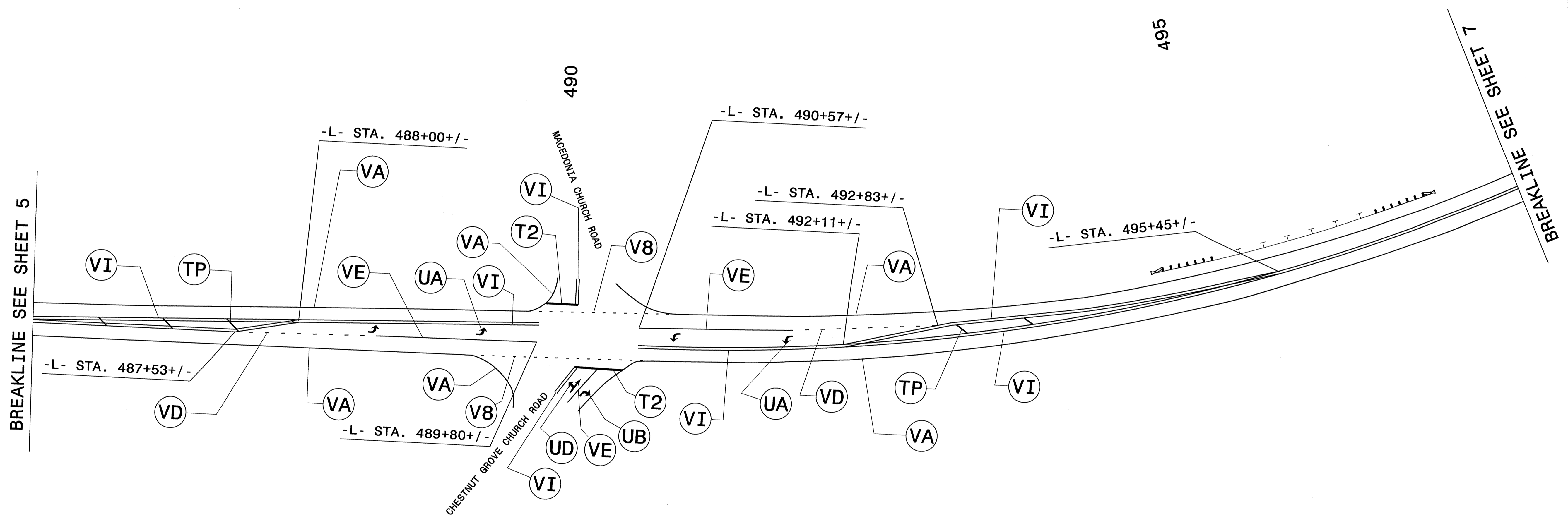
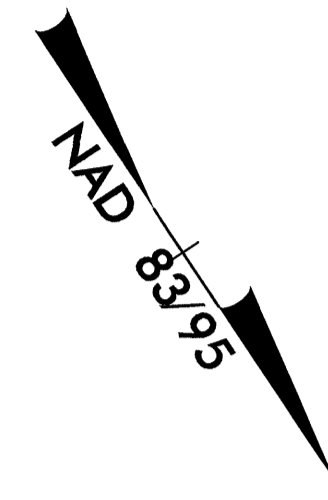

04-JUN-2013 07:19  
 C:\Users\wjohnson\Documents\CADD\MP\R-3101\_Sgn\_PMP\_Sheets.dgn  
 wjohnson AT 12:24:518

**PAVEMENT MARKINGS**



TIP NO. R-3101	SHEET NO. PMP-7
APPROVED: <i>RW</i>	
DATE: 6/5/13	
SEAL	

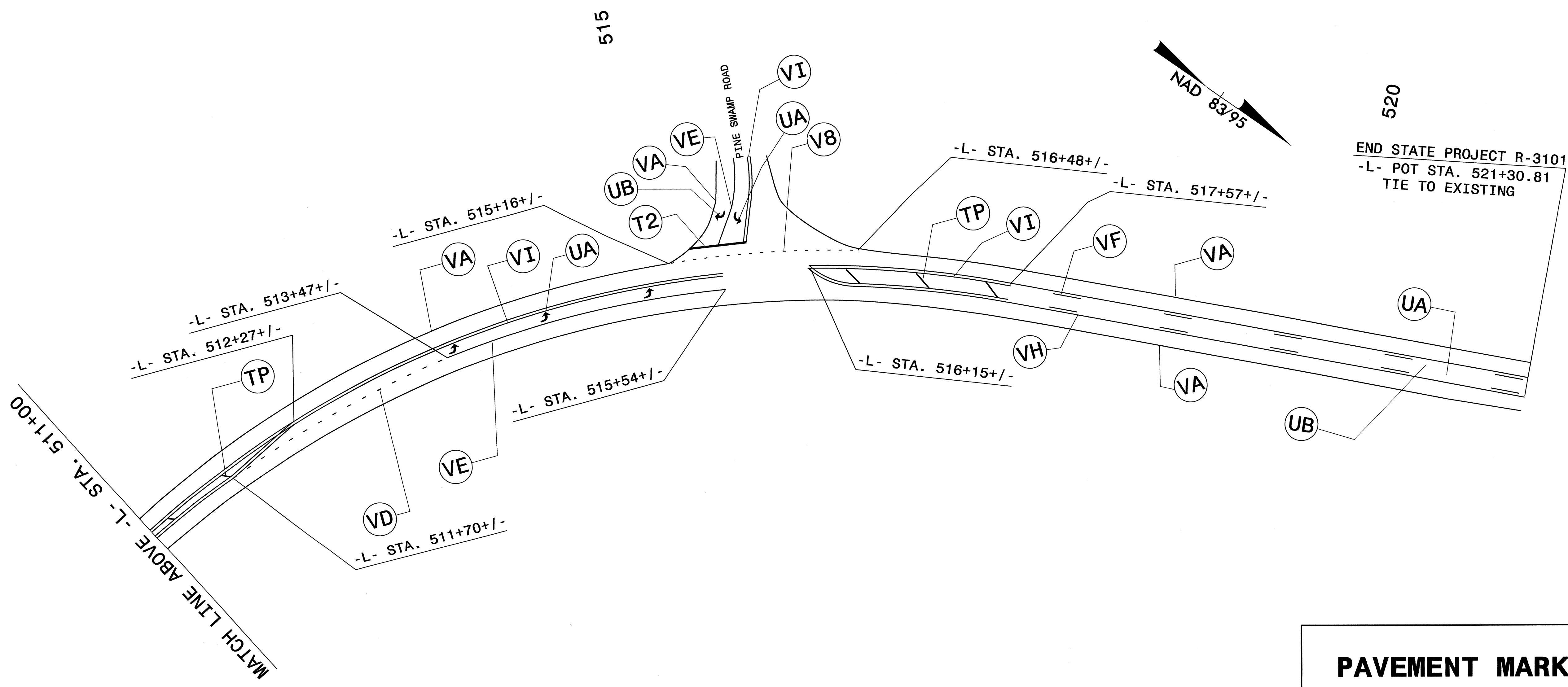
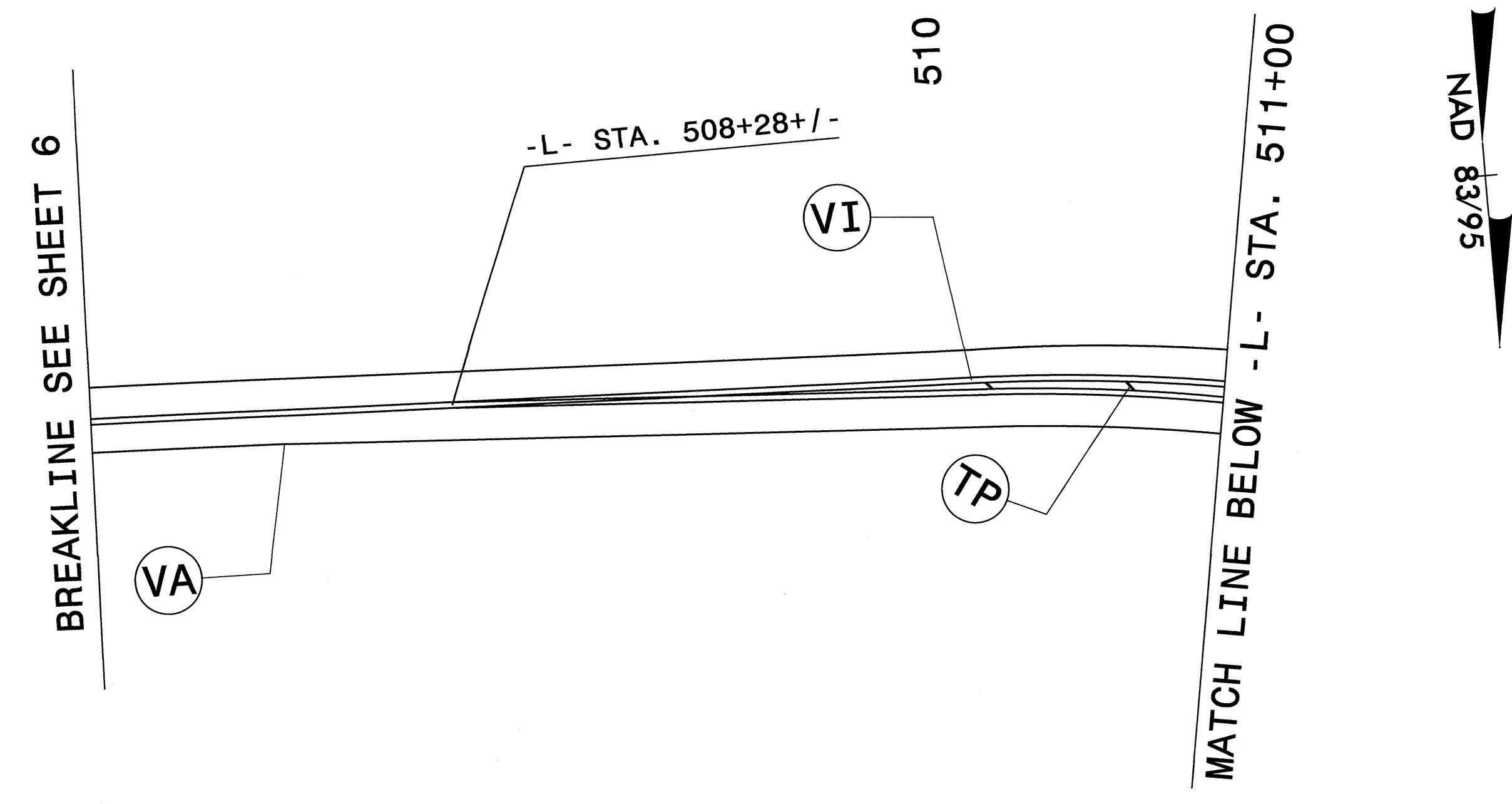

**PAVEMENT MARKINGS**

64-JUN-2013 07:22  
 gmmr\CADD\PMR-R-3101\_Sgn\_PMP\_Sheets.dgn  
 Walter Johnson AT 1247518