

STATE OF NORTH CAROLINA  
DIVISION OF HIGHWAYS  
**ALLEGHANY COUNTY**

PRIMARY & SECONDARY ASPHALT RESURFACING

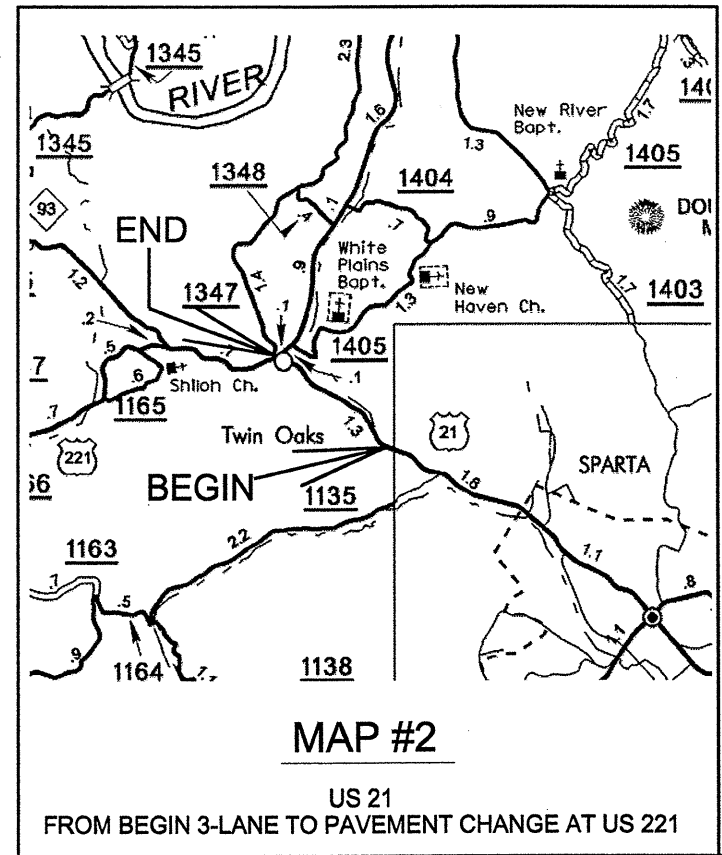

MAP #2

US 21  
FROM BEGIN 3-LANE TO PAVEMENT CHANGE AT US 221

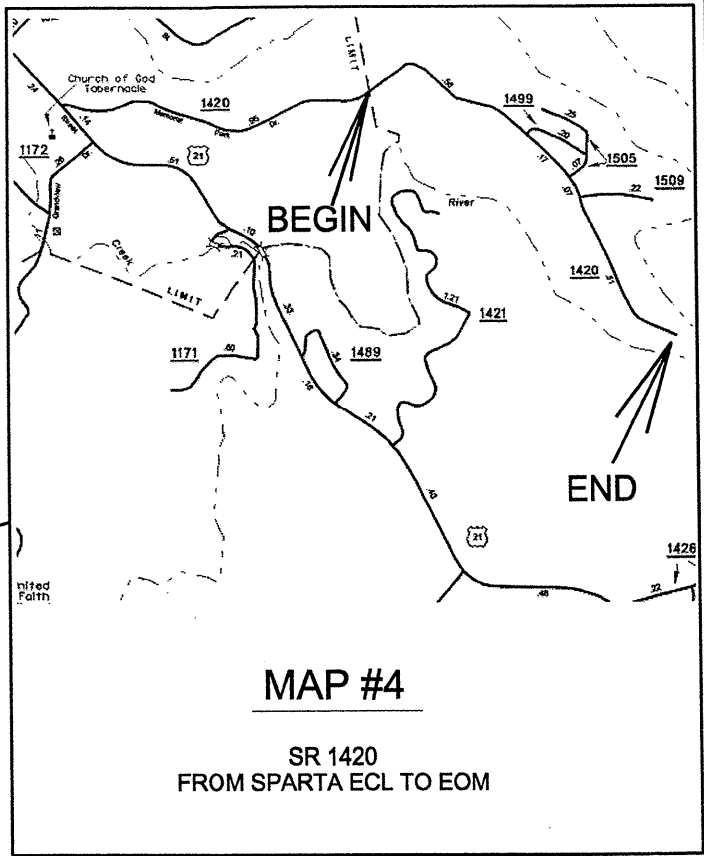
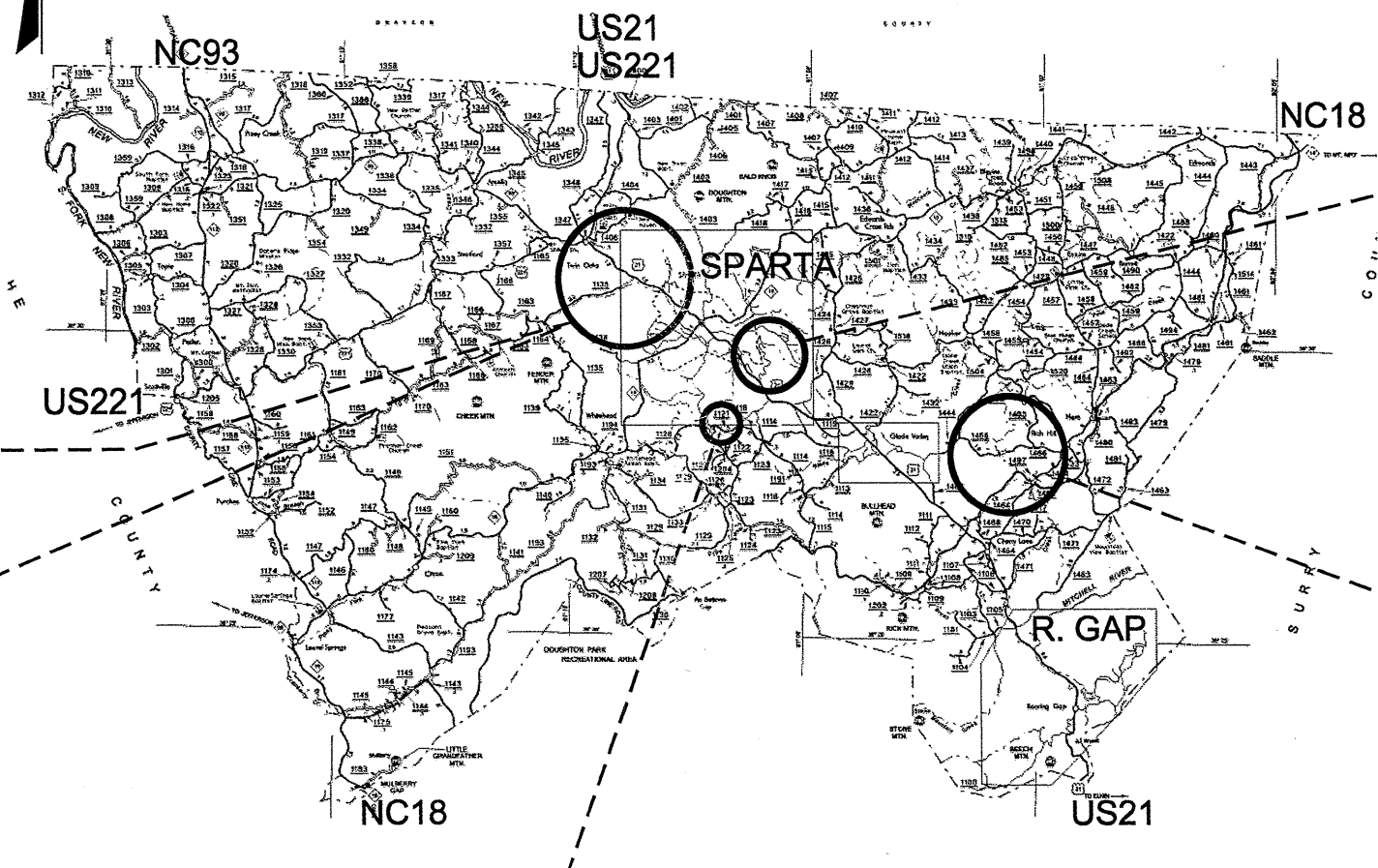

MAP #4

SR 1420  
FROM SPARTA ECL TO EOM

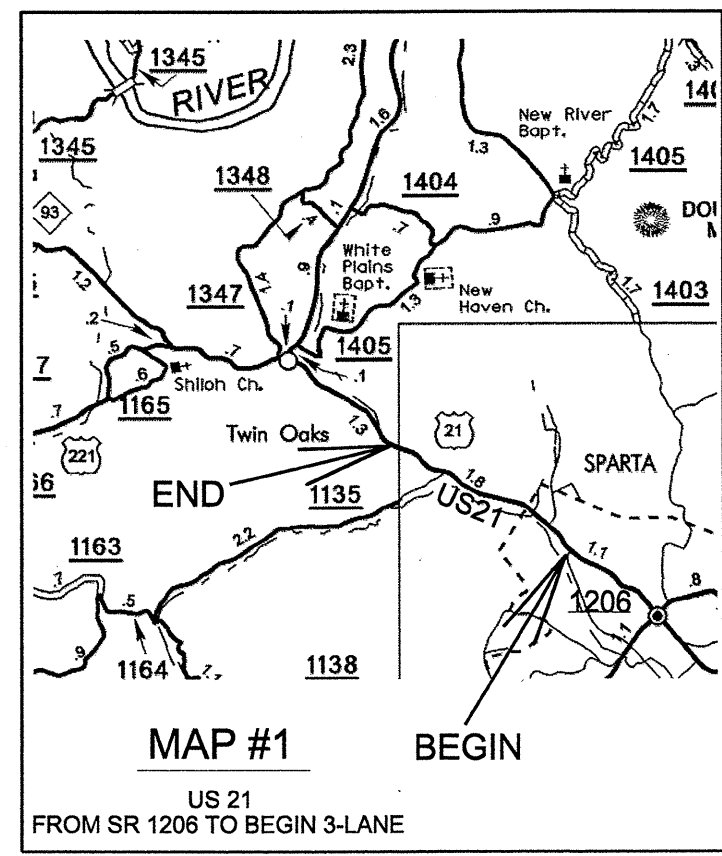

MAP #1

US 21  
FROM SR 1206 TO BEGIN 3-LANE

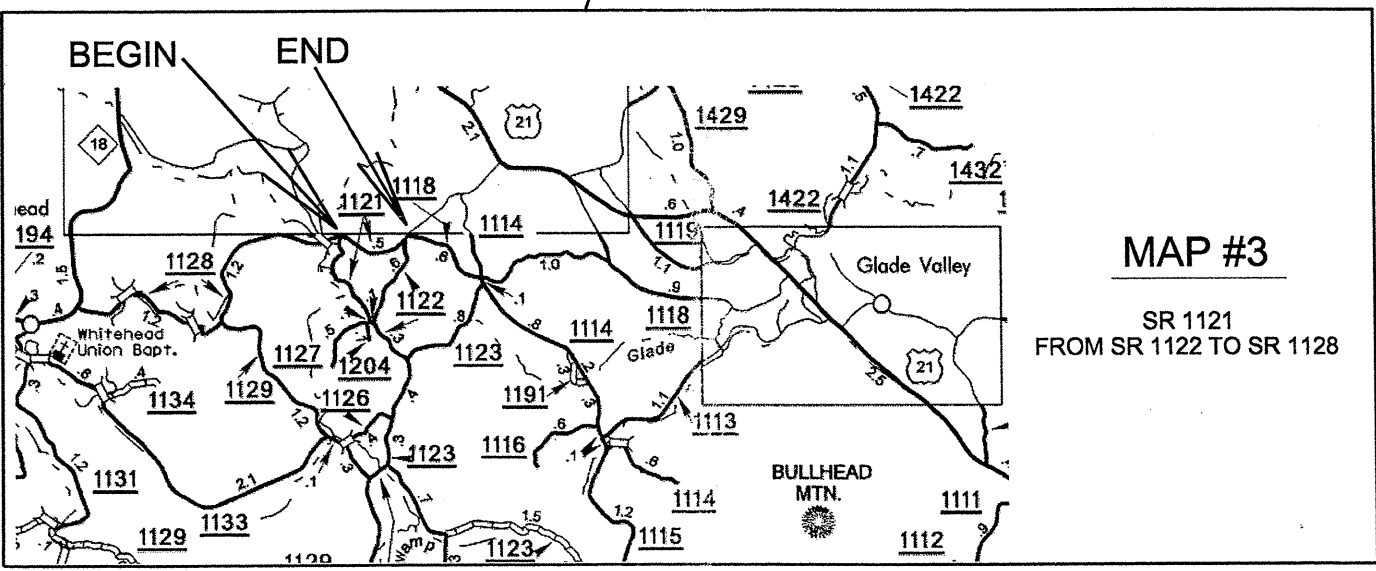

MAP #3

SR 1121  
FROM SR 1122 TO SR 1128

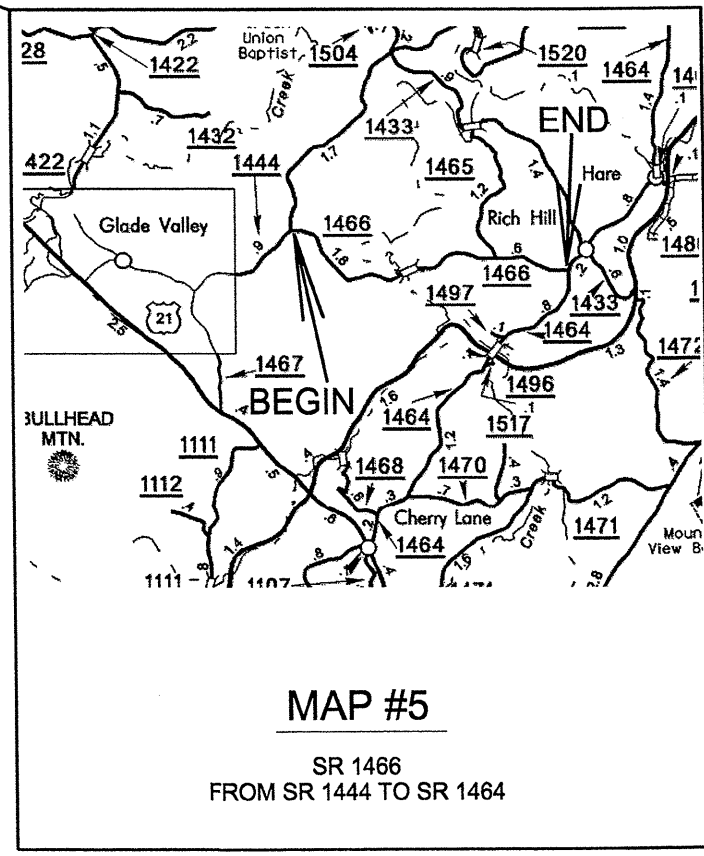

MAP #5

SR 1466  
FROM SR 1444 TO SR 1464

8/17/99

PROJECT REFERENCE NO. 11CRJ005121	SHEET NO. 2
--------------------------------------	----------------

STATE OF NORTH CAROLINA  
DIVISION OF HIGHWAYS

**ASHE COUNTY**

PRIMARY ASPHALT RESURFACING



MAP #6 NC 194  
FROM NC 88 TO SR 1644

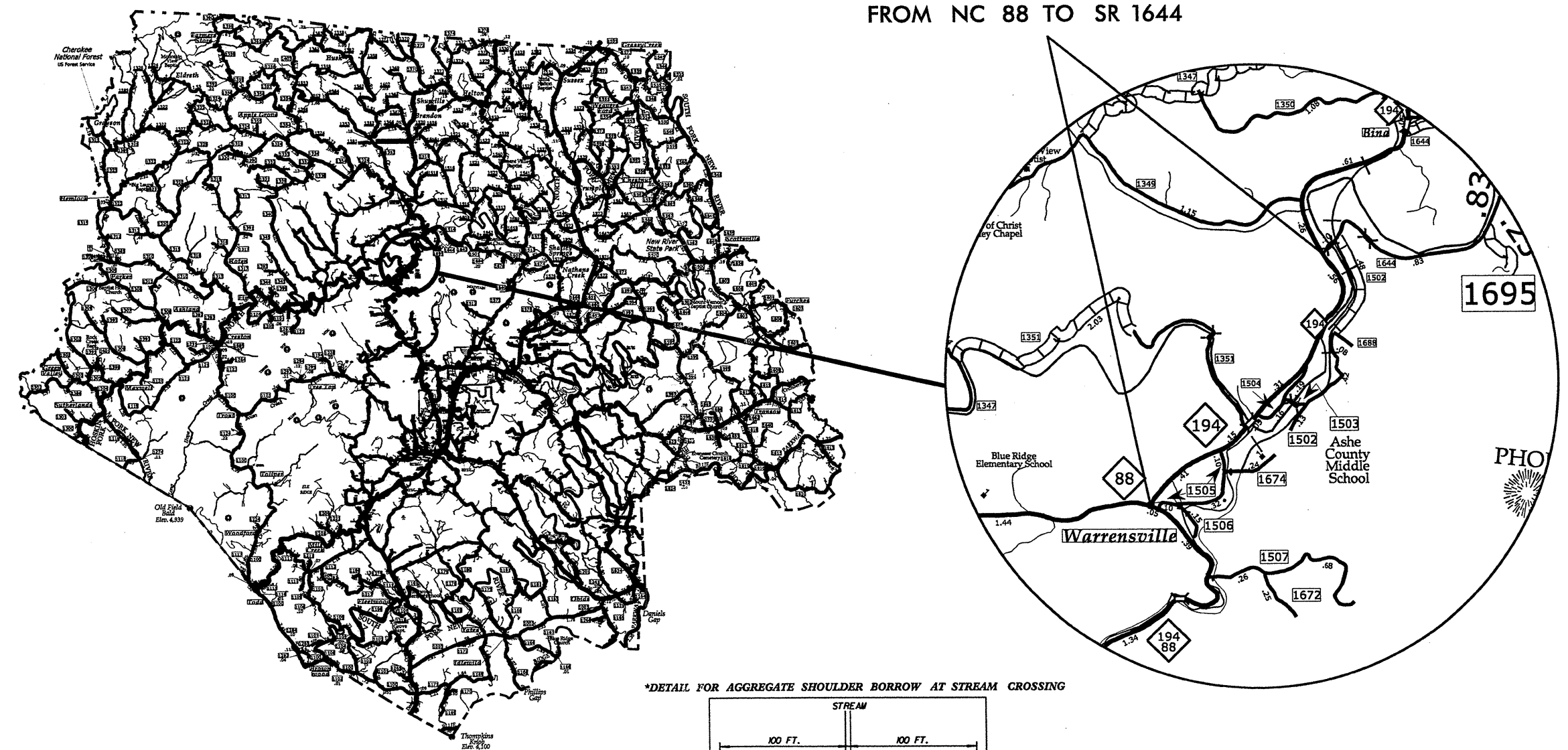

\*DETAIL FOR AGGREGATE SHOULDER BORROW AT STREAM CROSSING

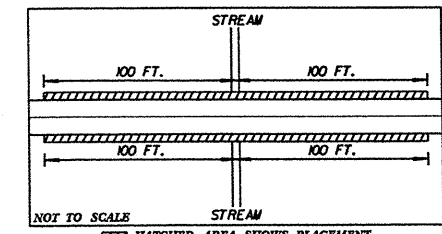

MAP #6  
AGGREGATE SHOULDER BORROW TO BE PLACED AS FOLLOWS:  
\* APPROX. STATION 22+00 TO 32+20 RIGHT  
\* APPROX. STATION 54+00 TO 70+00 RIGHT  
\* APPROX. STATION 78+00 (SEE DETAIL)

8/17/99

STATE OF NORTH CAROLINA  
DIVISION OF HIGHWAYS

**ASHE COUNTY**

PRIMARY ASPHALT RESURFACING



MAP #8 NC 88  
FROM SR 1342 TO SR 1340

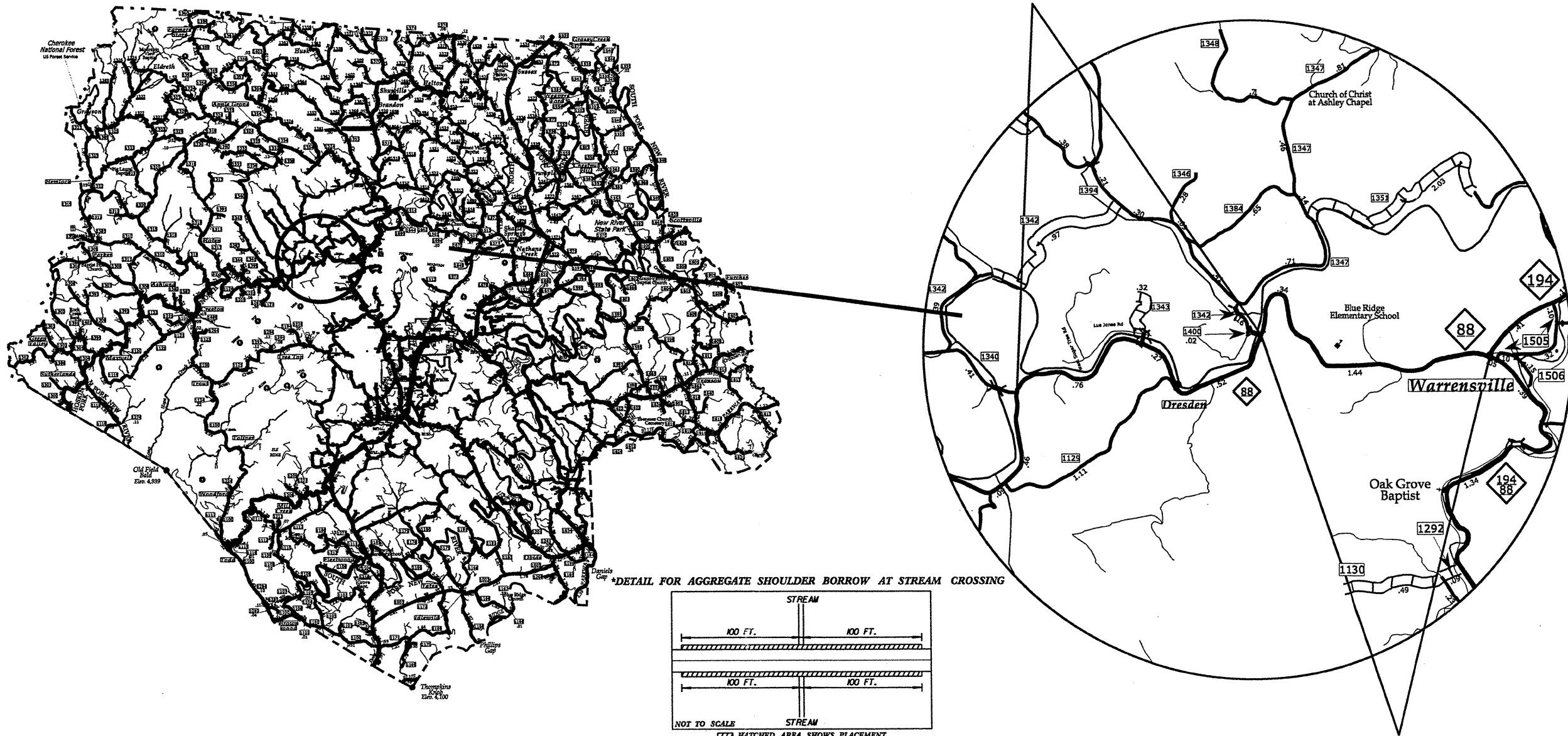

\*DETAIL FOR AGGREGATE SHOULDER BORROW AT STREAM CROSSING

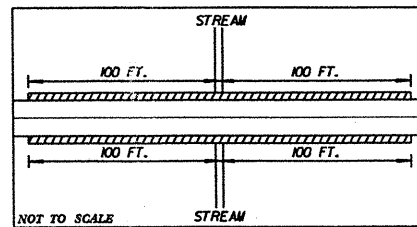

/// HATCHED AREA SHOWS PLACEMENT OF AGGREGATE SHOULDER BORROW

- MAP #8**  
AGGREGATE SHOULDER BORROW TO BE PLACED AS FOLLOWS:
- \* APPROX. STATION 0+00 TO 8+00 RIGHT
  - \* APPROX. STATION 13+50 (SEE DETAIL)
  - \* APPROX. STATION 17+00 (SEE DETAIL)
  - \* APPROX. STATION 19+50 (SEE DETAIL)
  - \* APPROX. STATION 19+50 TO 23+10 RIGHT
  - \* APPROX. STATION 31+50 (SEE DETAIL)
  - \* APPROX. STATION 46+50 TO 56+00 RIGHT
  - \* APPROX. STATION 67+25 (SEE DETAIL)
  - \* APPROX. STATION 72+00 TO 76+00 RIGHT

MAP #7 NC 88  
FROM NC 194 TO SR 1342

8/17/99

STATE OF NORTH CAROLINA  
DIVISION OF HIGHWAYS

**ASHE COUNTY**

SECONDARY ASPHALT RESURFACING

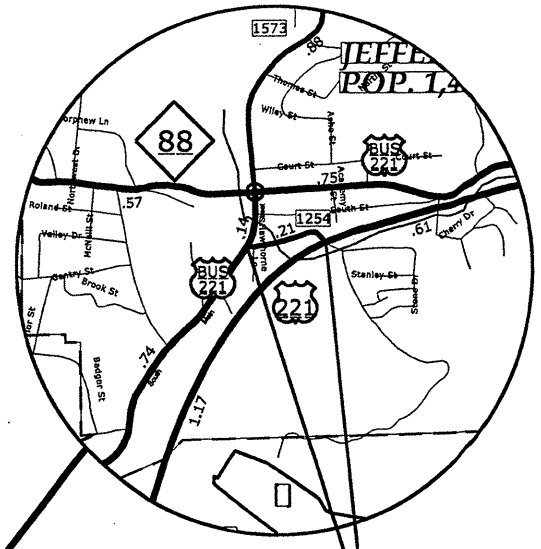

MAP #10 SR 1254  
FROM US 221 TO US 221 BUS

MAP #9 SR 1315  
FROM NC 88  
TO TENNESSEE STATE LINE

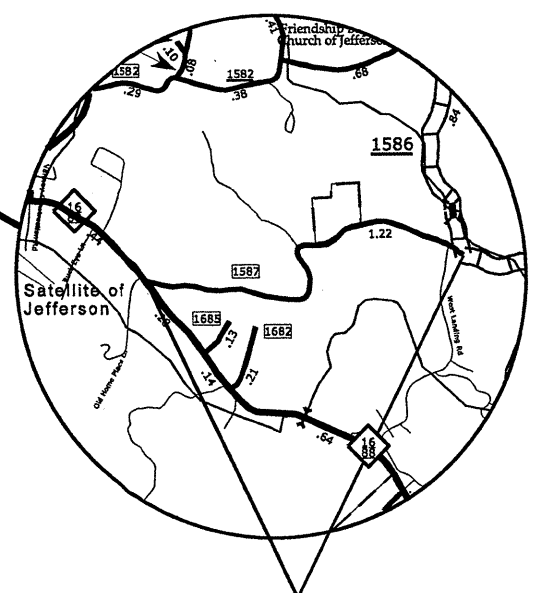
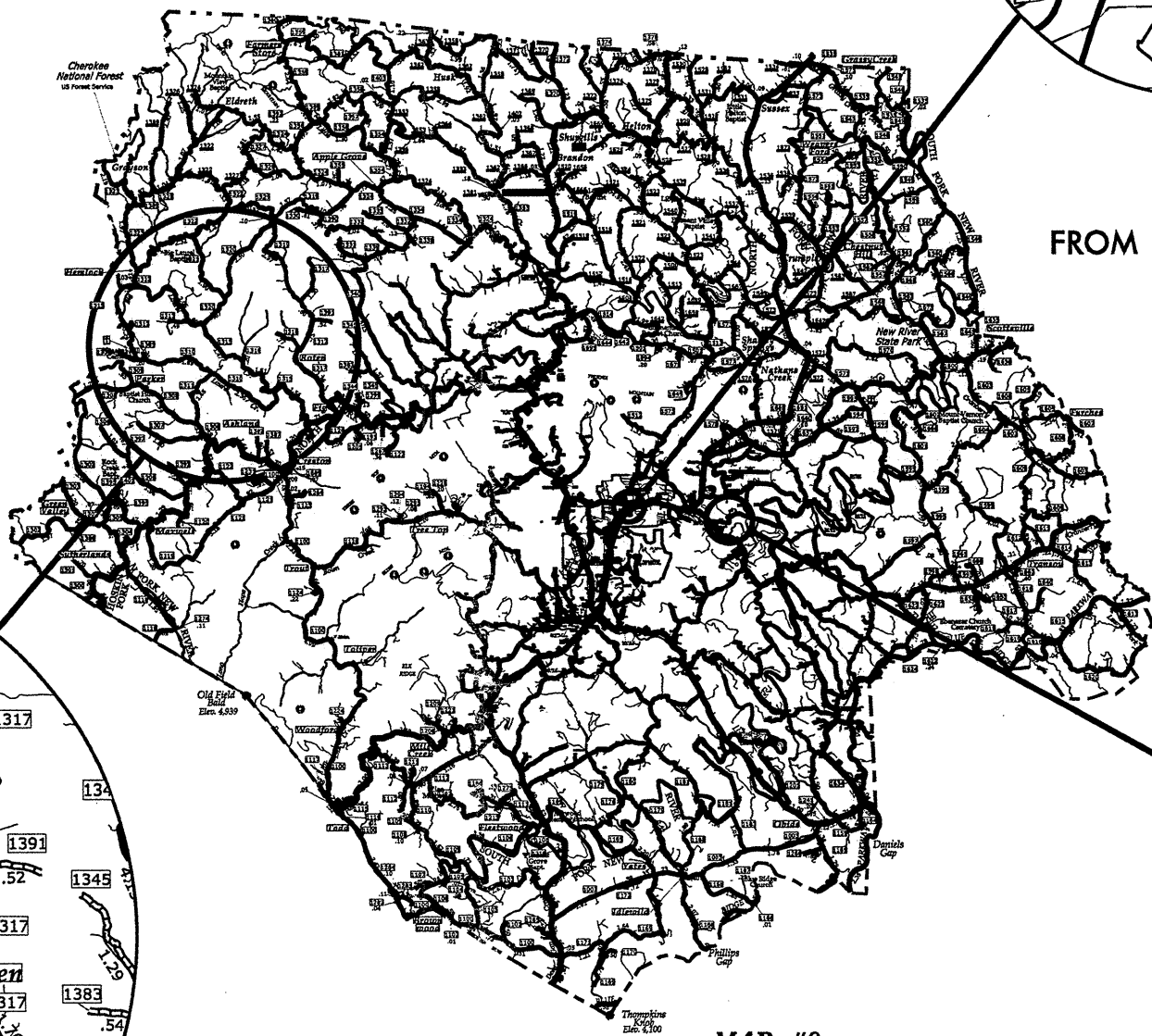
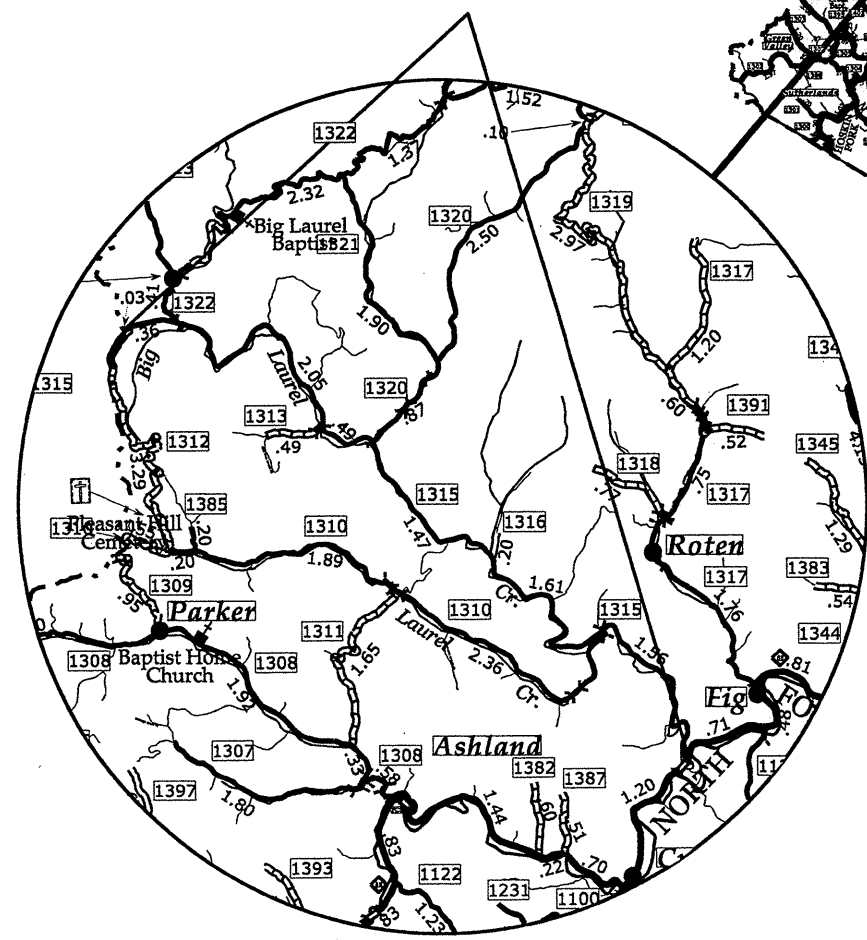

MAP #11 SR 1587  
FROM NC 16 TO EOP

MAP #9  
AGGREGATE SHOULDER BORROW TO BE PLACED ALONG ENTIRE MAP LENGTH

MAP #10  
AGGREGATE SHOULDER BORROW TO BE PLACED ALONG ENTIRE MAP LENGTH

MAP #11  
AGGREGATE SHOULDER BORROW TO BE PLACED AS FOLLOWS:  
\* APPROX. STATION 34+75 TO 40+30 LEFT

8/17/99

STATE OF NORTH CAROLINA  
DIVISION OF HIGHWAYS

**ASHE COUNTY**

SECONDARY ASPHALT RESURFACING

MAP #13 SR 1283  
FROM US 221 TO SR 1149

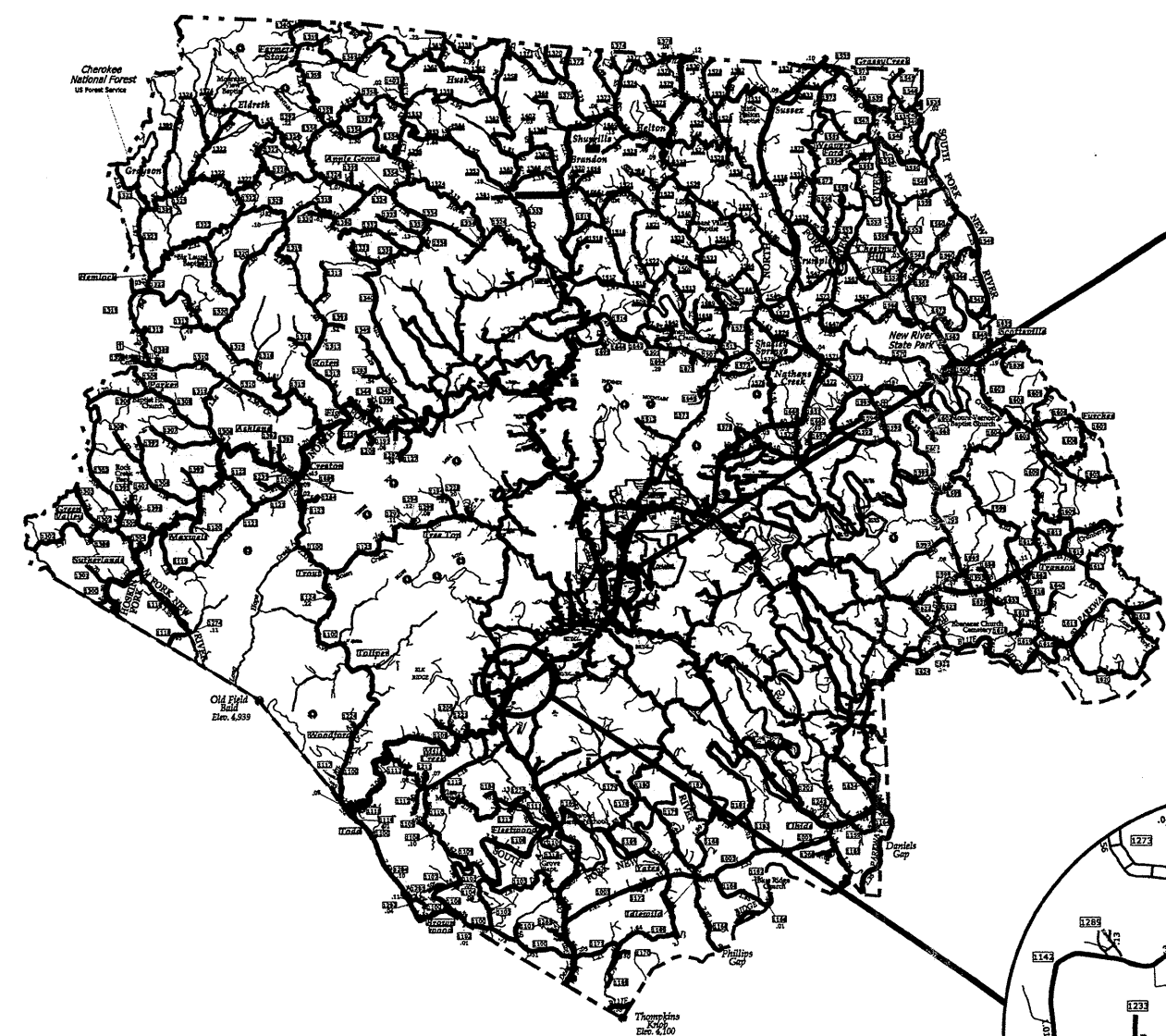
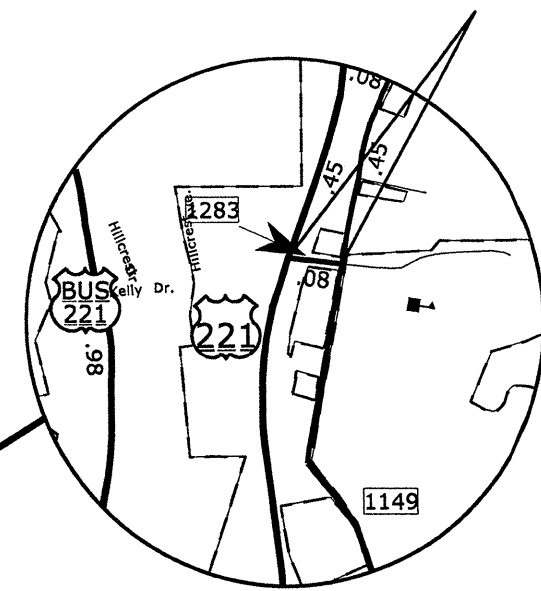

MAP #12 SR 1143  
FROM SR 1248 TO US 221

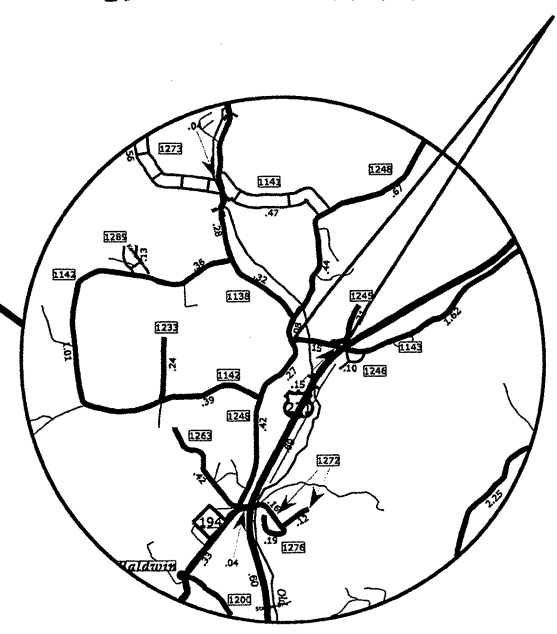

\*DETAIL FOR AGGREGATE SHOULDER BORROW AT STREAM CROSSING

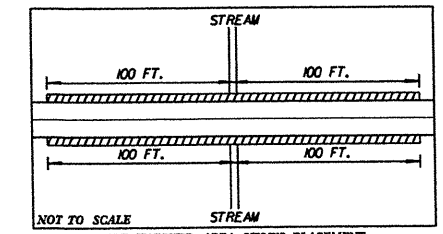

NOT TO SCALE  
HATCHED AREA SHOWS PLACEMENT OF AGGREGATE SHOULDER BORROW

MAP #12  
AGGREGATE SHOULDER BORROW TO BE PLACED AS FOLLOWS:  
\* APPROX. STATION 2+60 (SEE DETAIL)

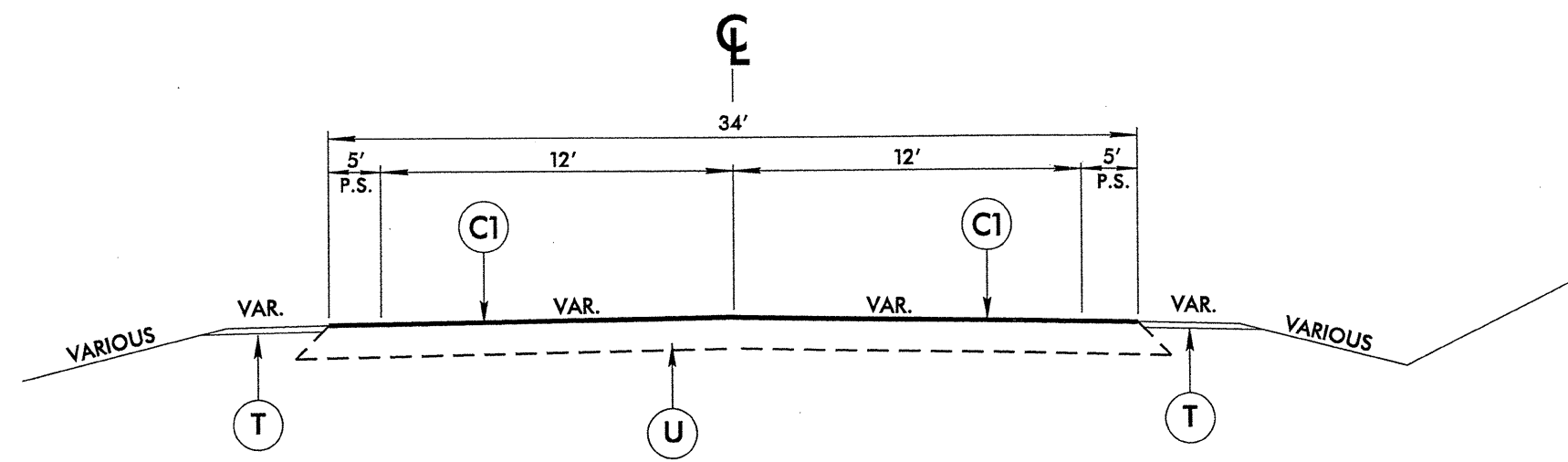

**TYPICAL SECTION NO. 1**

MAP 1 - US 21 FROM SR 1206 TO BEGIN 3-LANE

PAVEMENT SCHEDULE	
C1	PROP. APPROX. 1½" ASPHALT CONCRETE SURFACE COURSE, TYPE S9.5B, AT AN AVERAGE RATE OF 168 LBS. PER SQ. YD.
C2	PROP. APPROX. 1½" ASPHALT CONCRETE SURFACE COURSE, TYPE SF9.5A, AT AN AVERAGE RATE OF 165 LBS. PER SQ. YD.
T	SHOULDER RECONSTRUCTION
U	EXISTING PAVEMENT
V1	INCIDENTAL MILLING

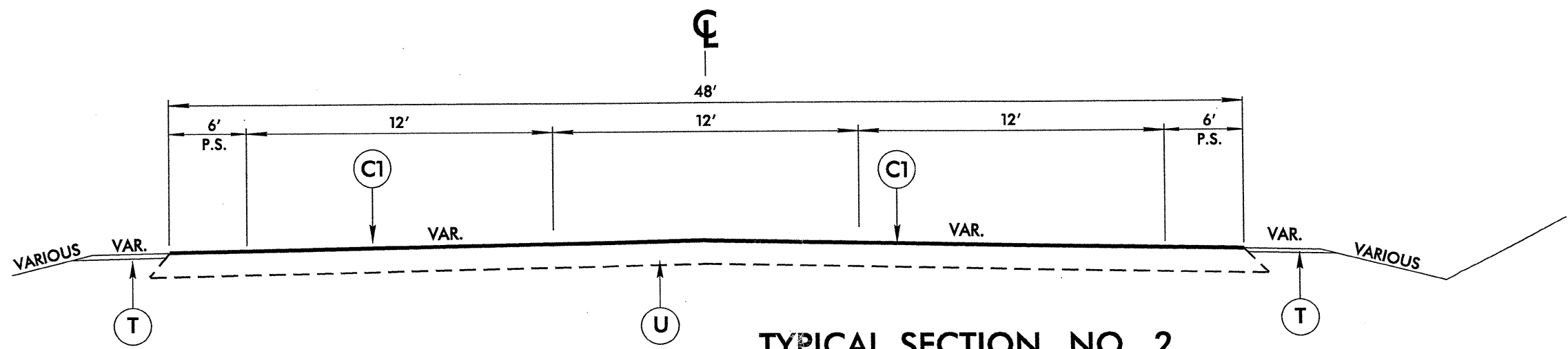

**TYPICAL SECTION NO. 2**

MAP 2 - US 21 FROM BEGIN 3-LANE TO PAVEMENT CHANGE AT US 221

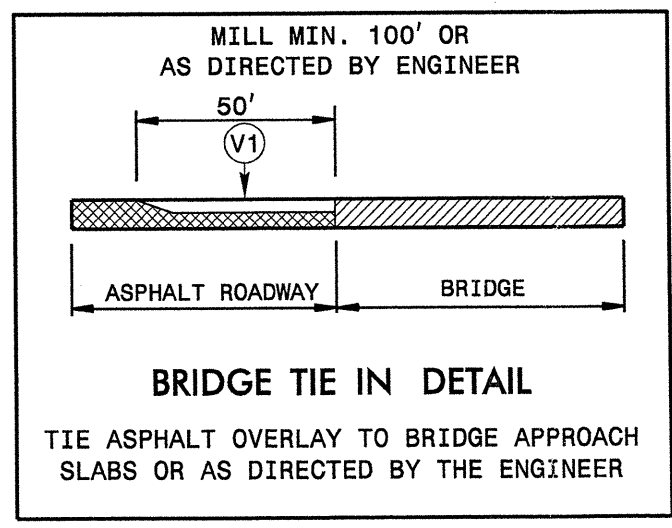
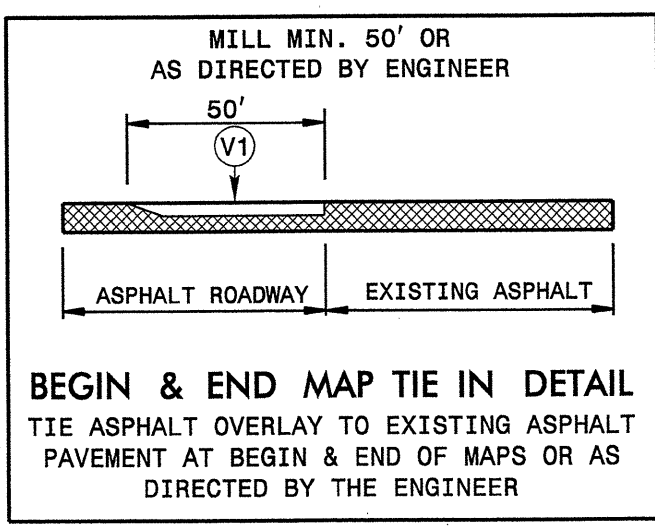

**ALLEGHANY & ASHE COUNTIES  
PRIMARY AND SECONDARY  
RESURFACING**

DIVISION II

REVISIONS	INIT.	DATE

SCALE: N/A DATE: 06/2013

PREPARED BY: S.B. DARNELL  
REVIEWED BY: J.D. WOOD

**N.C. DEPARTMENT of TRANSPORTATION  
DIVISION of HIGHWAYS  
DIVISION ELEVEN**

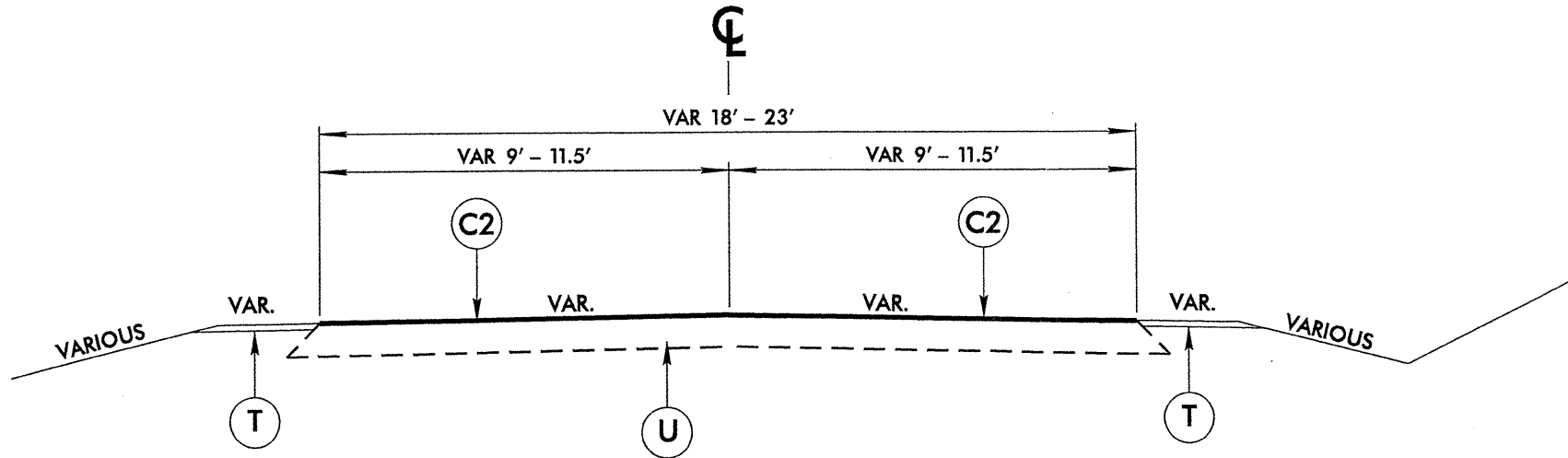

### TYPICAL SECTION NO. 3

- MAP 3 - SR 1121 FROM SR 1122 TO SR 1128
- MAP 4 - SR 1420 FROM SPARTA ECL TO EOM
- MAP 5 - SR 1466 FROM SR 1444 TO SR 1464
- MAP 11 - SR 1587 FROM NC 16 TO EOP
- MAP 12 - SR 1143 FROM SR 1248 TO US 221

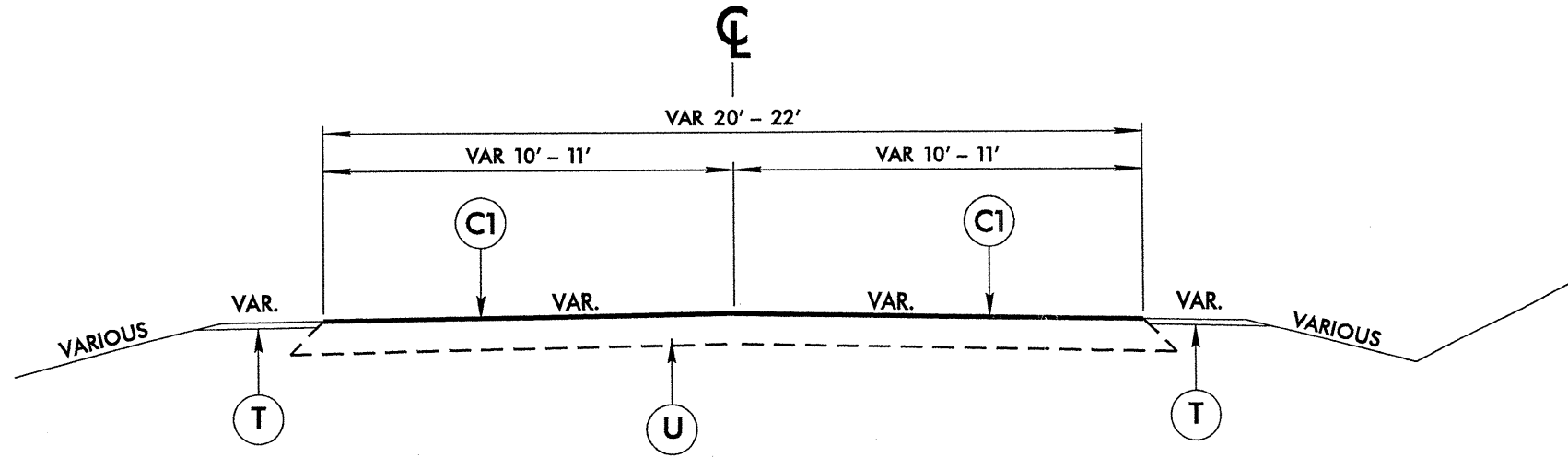

### TYPICAL SECTION NO. 4

- MAP 6 - NC 194 FROM NC 88 TO SR 1644
- MAP 7 - NC 88 FROM NC 194 TO SR 1342
- MAP 8 - NC 88 FROM SR 1342 TO SR 1340
- MAP 9 - SR 1315 FROM NC 88 TO TN STATE LINE

PAVEMENT SCHEDULE	
C1	PROP. APPROX. 1 1/2" ASPHALT CONCRETE SURFACE COURSE, TYPE S9.5B, AT AN AVERAGE RATE OF 168 LBS. PER SQ. YD.
C2	PROP. APPROX. 1 1/2" ASPHALT CONCRETE SURFACE COURSE, TYPE SF9.5A, AT AN AVERAGE RATE OF 165 LBS. PER SQ. YD.
T	SHOULDER RECONSTRUCTION
U	EXISTING PAVEMENT
V1	INCIDENTAL MILLING

<b>ALLEGHANY &amp; ASHE COUNTIES PRIMARY AND SECONDARY RESURFACING</b>		
DIVISION II		
REVISIONS	INIT.	DATE
N.C. DEPARTMENT of TRANSPORTATION DIVISION of HIGHWAYS DIVISION ELEVEN		SCALE: N/A DATE: 06/2013 PREPARED BY: S.B. DARNELL REVIEWED BY: J.D. WOOD REVIEWED BY:

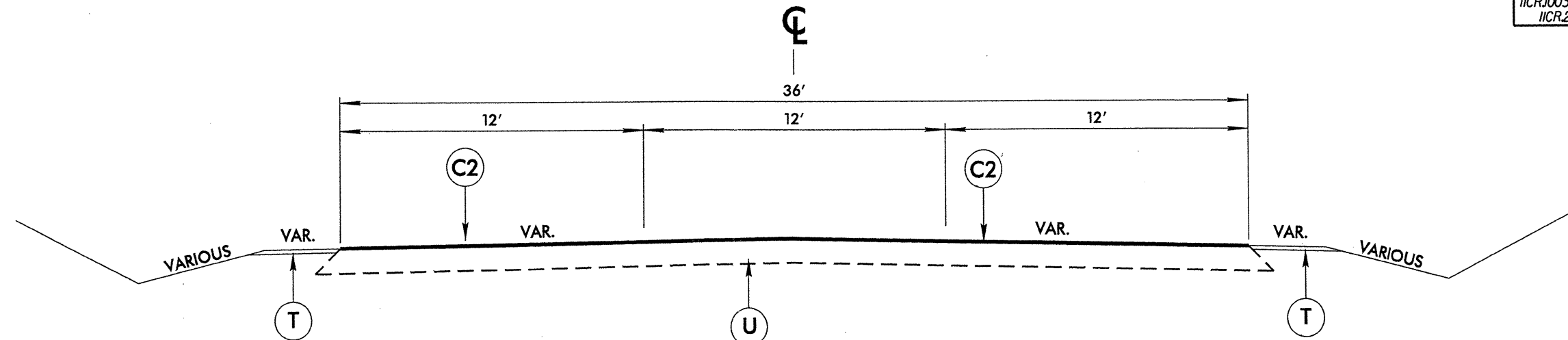

**TYPICAL SECTION NO. 5**

MAP 10 - SR 1254 FROM US 221 TO US 221 BUS

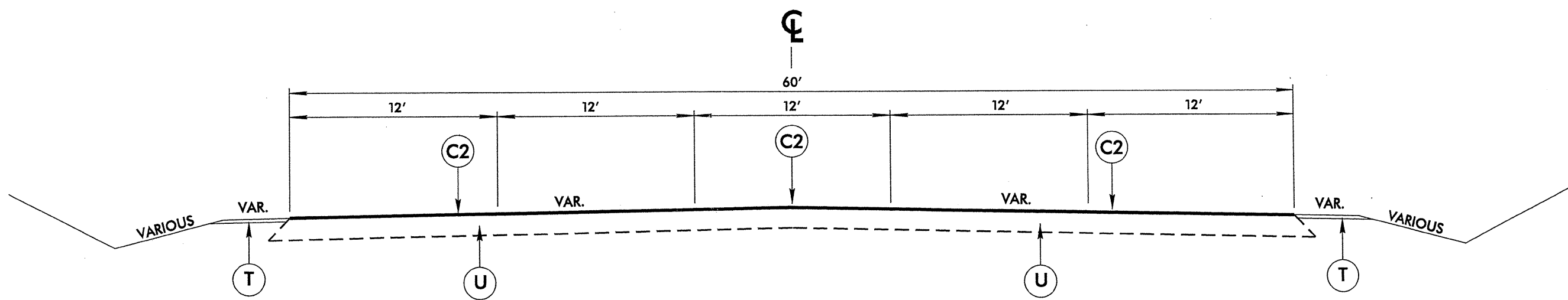

**TYPICAL SECTION NO. 6**

MAP 13 - SR 1283 FROM US 221 TO SR 1149

PAVEMENT SCHEDULE	
C1	PROP. APPROX. 1½" ASPHALT CONCRETE SURFACE COURSE, TYPE S9.5B, AT AN AVERAGE RATE OF 168 LBS. PER SQ. YD.
C2	PROP. APPROX. 1½" ASPHALT CONCRETE SURFACE COURSE, TYPE SF9.5A, AT AN AVERAGE RATE OF 165 LBS. PER SQ. YD.
T	SHOULDER RECONSTRUCTION
U	EXISTING PAVEMENT
V1	INCIDENTAL MILLING

<b>ALLEGHANY &amp; ASHE COUNTIES PRIMARY AND SECONDARY RESURFACING</b>		
DIVISION II		
REVISIONS	INIT.	DATE
N.C. DEPARTMENT of TRANSPORTATION DIVISION of HIGHWAYS DIVISION ELEVEN		SCALE: N/A    DATE: 05/2013 PREPARED BY: S.B. DARNELL REVIEWED BY: J.D. WOOD REVIEWED BY:



PROJECT NO.	SHEET NO.	TOTAL NO.
11CR.10031.21, 11CR.20031.21 11CR.10051.21, ETC.	9	

### SUMMARY OF QUANTITIES

PROJECT NO	COUNTY	MAP NO	ROUTE	DESCRIPTION	TYP NO	LANES	LANE TYPE	FINAL SURFACE TESTING REQUIRED	WARM MIX ASPHALT REQUIRED	LENGTH MI	WIDTH FT	BORROW EXCAVATION CY	INCIDENTAL STONE BASE TONS	SHOULDER RECONSTRUCTION SMI	INCIDENTAL MILLING SY	SURFACE COURSE, S9.5B TONS	SURFACE COURSE, SF9.5A TONS	ASPHALT BINDER FOR PLANT MIX TONS	PATCHING EXISTING PAVEMENT TONS	ADJ. OF METER OR VALVE BOX EA	SEED & MULCHING AC	PAVED TRENCHING (2 - 2") LF	UNPAVED TRENCHING (2 - 2") LF	INDUCTIVE LOOP LF	LEAD-IN CABLE LF
11CR.10031.21	Alleghany	1	US 21	FROM SR 1206 TO BEGIN 3-LANE	1	2	2WU	NO	NO	1.27	34	254	50	2.54	190	2,235		134		7	0.90				
11CR.10031.21	Alleghany	2	US 21	FROM BEGIN 3-LANE TO PAVEMENT CHANGE AT US 221	2	3	MU	NO	NO	0.92	48	184	50	1.84	270	2,280		137			0.65				
<b>TOTAL FOR PROJ NO. 11CR.10031.21</b>										<b>2.19</b>		<b>438</b>	<b>100</b>	<b>4.38</b>	<b>460</b>	<b>4,515</b>		<b>271</b>		<b>7</b>	<b>1.55</b>				
11CR.20031.21	Alleghany	3	SR 1121	FROM SR 1122 TO SR 1128	3	2	2WU	NO	NO	0.46	18	92	25	0.92	200		435	29			0.30				
11CR.20031.21	Alleghany	4	SR 1420	FROM SPARTA ECL TO EOM	3	2	2WU	NO	NO	1.51	20	302	50	3.02	225		1,520	102			1.00				
11CR.20031.21	Alleghany	5	SR 1466	FROM SR 1444 TO SR 1464	3	2	2WU	NO	NO	2.3	20	460	100	4.60	225		2,270	152			1.65				
<b>TOTAL FOR PROJ NO. 11CR.20031.21</b>										<b>4.27</b>		<b>854</b>	<b>175</b>	<b>8.54</b>	<b>650</b>		<b>4,225</b>	<b>283</b>			<b>2.95</b>				
11CR.10051.21	Ashe	6	NC 194	FROM NC 88 TO SR 1644	4	2	2WU	NO	NO	1.49	21	298	65	2.98	470	1,650		99	160		1.10				
11CR.10051.21	Ashe	7	NC 88	FROM NC 194 TO SR 1342	4	2	2WU	NO	NO	1.48	22	296	30	2.96	250	1,650		99	155		1.05				
11CR.10051.21	Ashe	8	NC 88	FROM SR 1342 TO SR 1340	4	2	2WU	NO	NO	1.53	20	306	100	3.06	225	1,565		94	165		0.99				
<b>TOTAL FOR PROJ NO. 11CR.10051.21</b>										<b>4.5</b>		<b>900</b>	<b>195</b>	<b>9.00</b>	<b>945</b>	<b>4,865</b>		<b>292</b>	<b>480</b>		<b>3.14</b>				
11CR.20051.21	Ashe	9	SR 1315	FROM NC 88 TO TN STATE LINE	4	2	2WU	NO	NO	7.6	20	1,520	100	15.20	450	7,640		458	170		5.40				
11CR.20051.21	Ashe	10	SR 1254	FROM US 221 TO US 221 BUS	5	3	MU	NO	NO	0.2	36	40		0.40	400		365	24	25		0.15				
11CR.20051.21	Ashe	11	SR 1587	FROM NC 16 TO EOP	3	2	2WU	NO	NO	1.17	20	234	20	2.34	115		1,155	77	125		1.10				
11CR.20051.21	Ashe	12	SR 1143	FROM SR 1248 TO US 221	3	2	2WU	NO	NO	0.21	23	42	10	0.42	325		240	16	20		0.15				
11CR.20051.21	Ashe	13	SR 1283	FROM US 221 TO SR 1149	6	5	MU	NO	NO	0.08	60	16		0.16	670		240	16	10	1	0.05	50.00	50.00	360	100
<b>TOTAL FOR PROJ NO. 11CR.20051.21</b>										<b>9.26</b>		<b>1,852</b>	<b>130</b>	<b>18.52</b>	<b>1,960</b>	<b>7,640</b>	<b>2,000</b>	<b>591</b>	<b>350</b>	<b>1</b>	<b>6.85</b>	<b>50.00</b>	<b>50.00</b>	<b>360</b>	<b>100</b>
<b>GRAND TOTAL</b>										<b>20.22</b>		<b>4,044</b>	<b>600</b>	<b>40.44</b>	<b>4,015</b>	<b>17,020</b>	<b>6,225</b>	<b>1,437</b>	<b>830</b>	<b>8</b>	<b>14.49</b>	<b>50.00</b>	<b>50.00</b>	<b>360</b>	<b>100</b>

PROJECT NO.	SHEET NO.	TOTAL NO.
11CR.10031.21, 11CR.20031.21	10	
11CR.10051.21, ETC.		

## THERMOPLASTIC AND PAINT QUANTITIES

PROJECT NO	COUNTY	MAP NO	ROUTE	DESCRIPTION	TYP NO	LANES	LANE TYPE	LENGTH	WIDTH	4595000000-E	4510000000-N	4589000000-N	4810000000-E		4820000000-E	4835000000-E	4840000000-N		4845000000-N				4905000000-N		
										WORK ZONE ADVANCE/GENERAL WARNING SIGNING SF	LAW ENFORCEMENT HR	TEMPORARY TRAFFIC CONTROL LS	4" WHITE PAINT LF	4" YELLOW PAINT LF	8" YELLOW PAINT LF	24" WHITE PAINT LF	PAINT MSG SCHOOL EA	PAINT MSG ONLY EA	PAINT RT ARROW EA	PAINT LT ARROW EA	PAINT STR & RT ARROW EA	PAINT STR ARROW EA	PAINT STR & LT ARROW EA	SNOW PLOWABLE MARKERS EA	
11CR.10031.21	Alleghany	1	US 21	FROM SR 1206 TO BEGIN 3-LANE	1	2	2WU	1.27	34	183.21		*	26,822	26,822	420			2	4				150		
11CR.10031.21	Alleghany	2	US 21	FROM BEGIN 3-LANE TO PAVEMENT CHANGE AT US 221	2	3	MU	0.92	48	183.21		*	19,430	24,288	200								125		
<b>TOTAL FOR PROJ NO. 11CR.10031.21</b>								<b>2.19</b>		<b>366.42</b>		<b>0.25</b>	<b>46,252</b>	<b>51,110</b>	<b>620</b>			<b>2</b>	<b>4</b>				<b>275</b>		
													<b>97,362</b>												<b>6</b>
11CR.20031.21	Alleghany	3	SR 1121	FROM SR 1122 TO SR 1128	3	2	2WU	0.46	18	183.21		*	9,715	9,715											
11CR.20031.21	Alleghany	4	SR 1420	FROM SPARTA ECL TO EOM	3	2	2WU	1.51	20	183.21		*	31,891	31,891											
11CR.20031.21	Alleghany	5	SR 1466	FROM SR 1444 TO SR 1464	3	2	2WU	2.3	20	183.21		*	48,576	48,576											
<b>TOTAL FOR PROJ NO. 11CR.20031.21</b>								<b>4.27</b>		<b>549.63</b>		<b>0.25</b>	<b>90,182</b>	<b>90,182</b>											
													<b>180,364</b>												
11CR.10051.21	Ashe	6	NC 194	FROM NC 88 TO SR 1644	4	2	2WU	1.49	21	183.21		*	31,469	21,120									100		
11CR.10051.21	Ashe	7	NC 88	FROM NC 194 TO SR 1342	4	2	2WU	1.48	22	183.21	80	*	31,258	31,258	220	88	12		2				95		
11CR.10051.21	Ashe	8	NC 88	FROM SR 1342 TO SR 1340	4	2	2WU	1.53	20	183.21		*	32,314	32,314									100		
<b>TOTAL FOR PROJ NO. 11CR.10051.21</b>								<b>4.5</b>		<b>549.63</b>	<b>80</b>	<b>0.25</b>	<b>95,041</b>	<b>84,692</b>	<b>220</b>	<b>88</b>	<b>12</b>			<b>2</b>			<b>295</b>		
													<b>179,733</b>		<b>12</b>		<b>2</b>								
11CR.20051.21	Ashe	9	SR 1315	FROM NC 88 TO TN STATE LINE	4	2	2WU	7.6	20	183.20		*	160,512	160,512									502		
11CR.20051.21	Ashe	10	SR 1254	FROM US 221 TO US 221 BUS	5	3	MU	0.2	36	183.20		*	4,224	5,280		100		2	6	3			28		
11CR.20051.21	Ashe	11	SR 1587	FROM NC 16 TO EOP	3	2	2WU	1.17	20	183.20		*	24,710	24,710											
11CR.20051.21	Ashe	12	SR 1143	FROM SR 1248 TO US 221	3	2	2WU	0.21	23	183.20		*	4,435	4,435									14		
11CR.20051.21	Ashe	13	SR 1283	FROM US 221 TO SR 1149	6	5	MU	0.08	60	183.20		*	2,468	1,800		96	4	4	2		2	2	20		
<b>TOTAL FOR PROJ NO. 11CR.20051.21</b>								<b>9.26</b>		<b>916.00</b>		<b>0.25</b>	<b>196,349</b>	<b>196,737</b>		<b>196</b>	<b>4</b>	<b>6</b>	<b>8</b>	<b>3</b>	<b>2</b>	<b>2</b>	<b>564</b>		
													<b>393,086</b>		<b>4</b>		<b>21</b>								
<b>GRAND TOTAL</b>								<b>20.22</b>		<b>2,381.68</b>	<b>80</b>	<b>1</b>	<b>427,824</b>	<b>422,721</b>	<b>840</b>	<b>284</b>	<b>12</b>	<b>4</b>	<b>8</b>	<b>14</b>	<b>3</b>	<b>2</b>	<b>2</b>	<b>1,134</b>	
													<b>850,545</b>		<b>16</b>		<b>29</b>								

- NOTES:
- 1) DETAIL DOES NOT APPLY TO OGAFC AND ULTRA-THIN BONDED WEARING COURSE.
  - 2) BACKFILL SHOULDER WITH APPROVED MATERIAL.
  - 3) THE SHOULDER WEDGE DEVICE MAY BE DISENGAGED AT PAVED DRIVEWAYS AND SIDE STREETS.

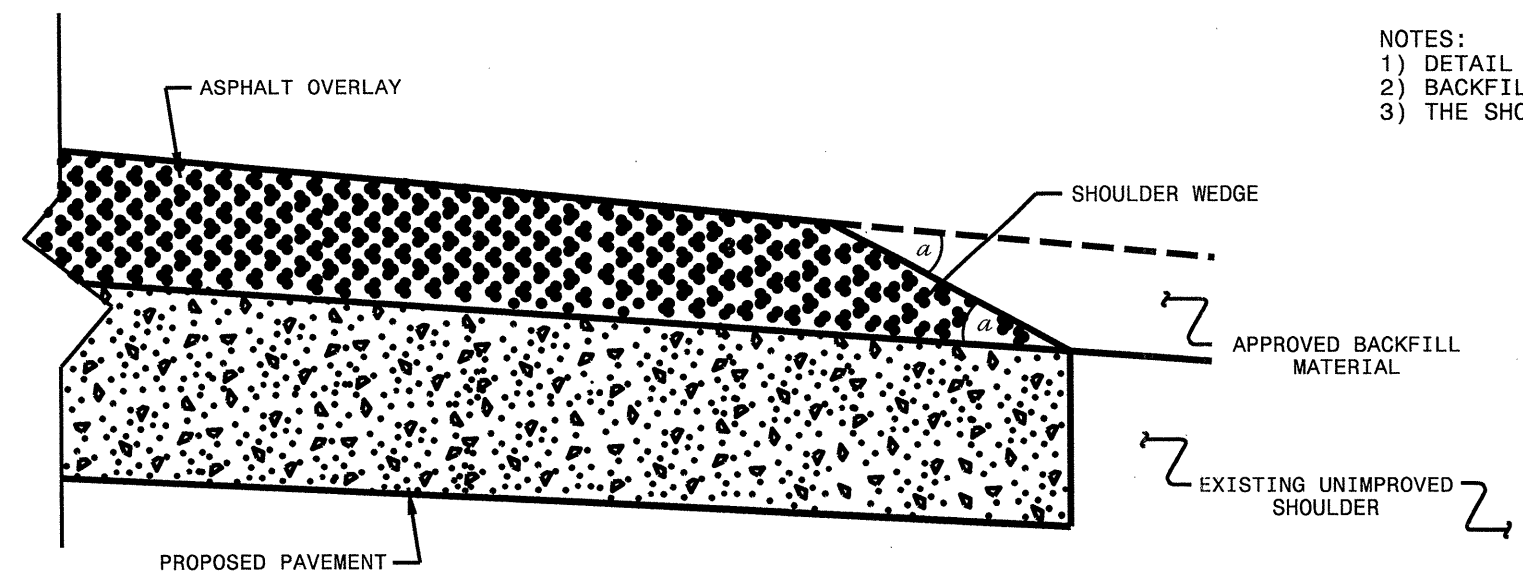

**SHOULDER WEDGE DETAIL**  
 (Resurfacing Projects w/ Widening or  
 with Existing Paved Shoulder having no dropoffs)

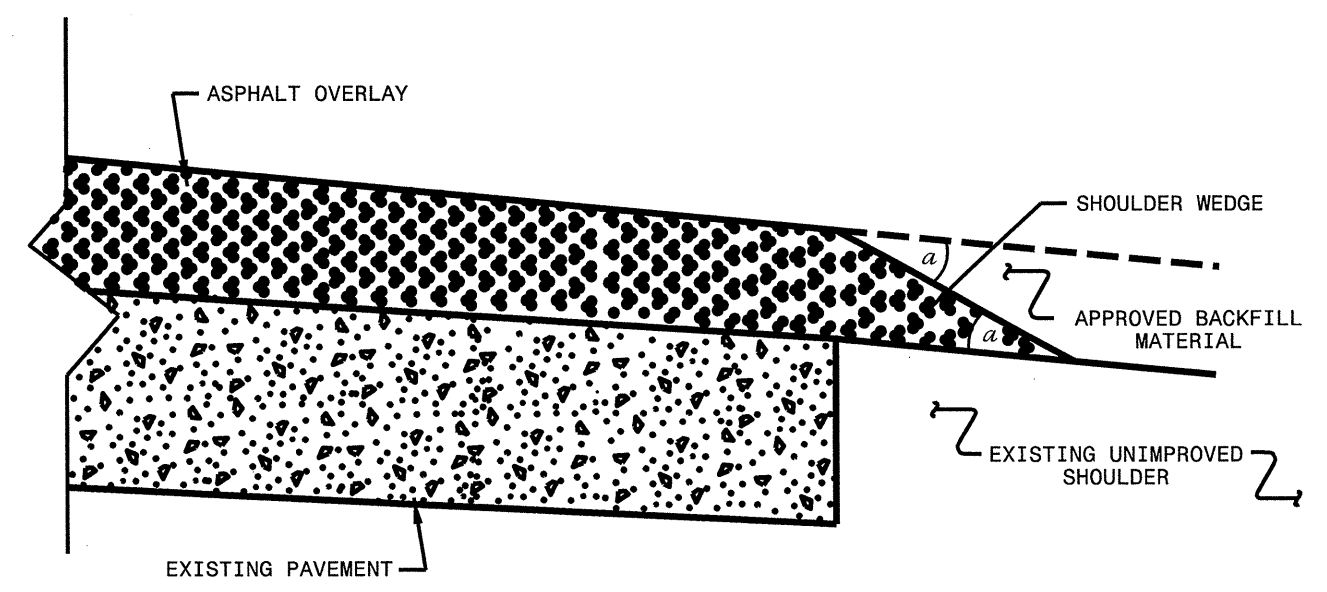

**SHOULDER WEDGE DETAIL**  
 (Resurfacing Projects w/ NO Widening)

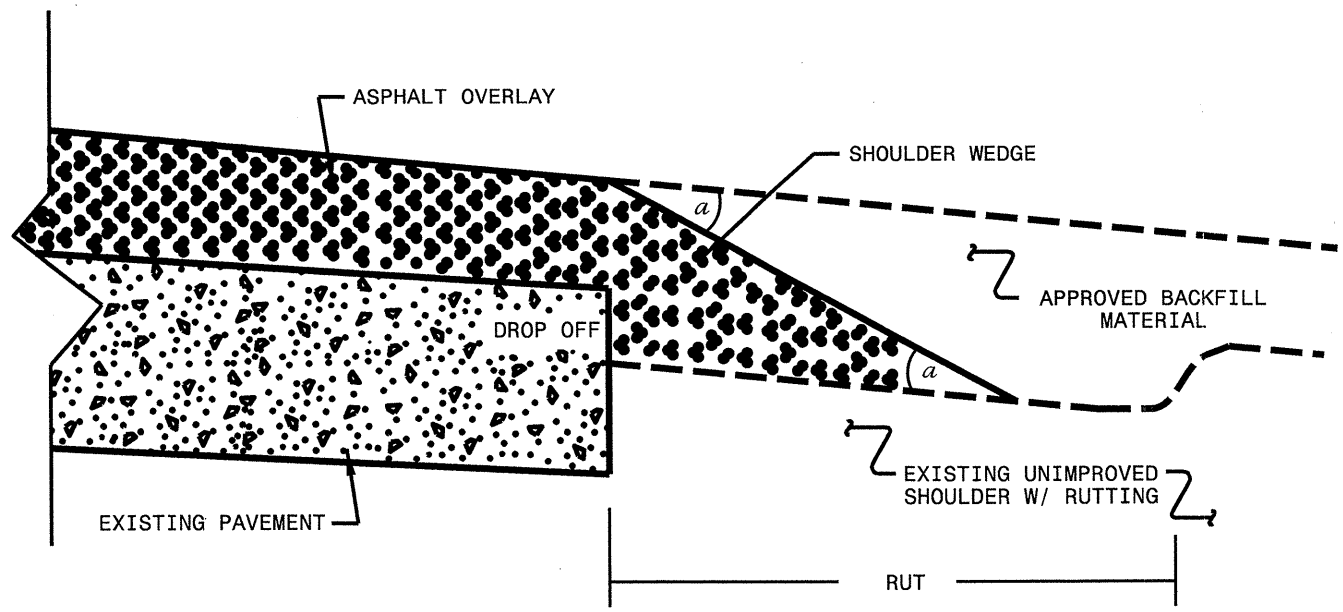

**SHOULDER WEDGE DETAIL**  
 (Resurfacing Adjacent to  
 Rutted Shoulder)

- SHOULDER WEDGE ANGLE = 30°

<b>CONTRACT STANDARDS AND DEVELOPMENT UNIT</b>			
Office 919-707-6950 FAX 919-250-4119			
<b>SHOULDER WEDGE DETAILS</b>			
ORIGINAL BY: T.SPELL	DATE: 7-19-11		
MODIFIED BY:	DATE: 10/18/12		
CHECKED BY:	DATE:		
FILE SPEC: s:\usr\details\stand\shoulderwedge\detail.dgn			

\*\*\*\*\*  
 SYSTEMS CONDITIONS  
 REMAIN \*\*\*\*\*

PROJECT REFERENCE NO.	SHEET NO.
SEE BELOW	SIG 1
11CR.10031.21	
11CR.20031.21	
11CR.10051.21	
11CR.20051.21	

### High Speed Detection [≥40 mph (64 km/hr)]

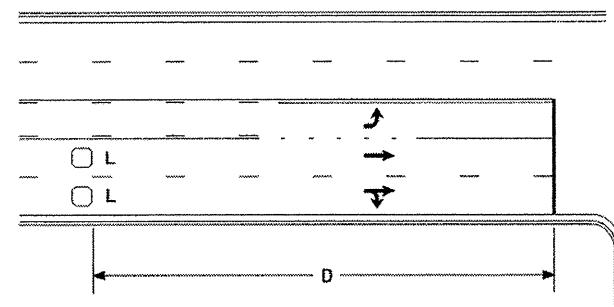

Speed Limit mph (km/hr)	D ft (m)
40 (64)	250 (75)
45 (72)	300 (90)
50 (80)	355 (110)
55 (88)	420 (130)

L = 6ft X 6ft (1.8m X 1.8m)  
Wired in series for TS1  
Controllers  
Wired separately for TS2,  
170, and 2070L Controllers

Volume Density Operation

OR

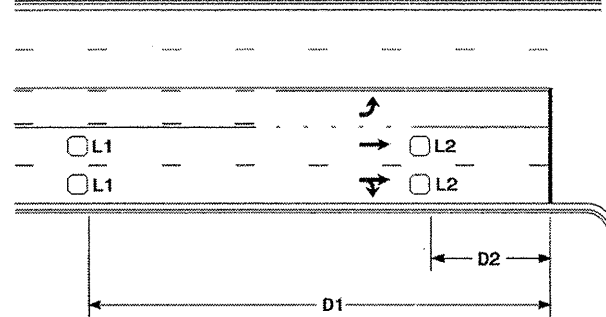

Speed Limit mph (km/hr)	D1 ft (m)	D2 ft (m)
40 (64)	250 (75)	80 (25)
45 (72)	300 (90)	90 (27)
50 (80)	355 (110)	100 (30)
55 (88)	420 (130)	110 (35)

L1 = 6ft X 6ft  
(1.8m X 1.8m)  
Wired in series  
L2 = 6ft X 6ft  
(1.8m X 1.8m)  
Wired in series

"Stretch" Operation

### Low Speed Detection [≤35 mph (56 km/hr)]

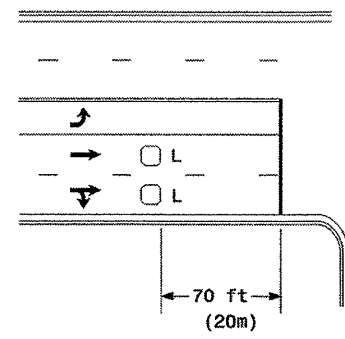

L = 6ft X 6ft (1.8m X 1.8m)  
Wired in series

OR

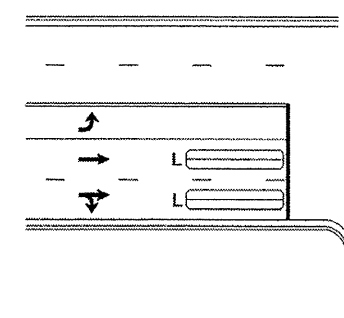

L = 6ft X 40ft (1.8m X 12.0m)  
Quadrupole loop, wired separately

### Left Turn Lane Detection

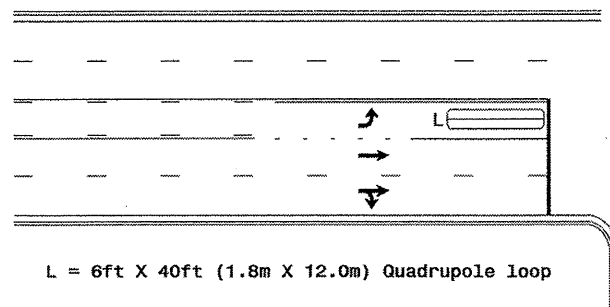

L = 6ft X 40ft (1.8m X 12.0m) Quadrupole loop

Presence Loop Detection

OR

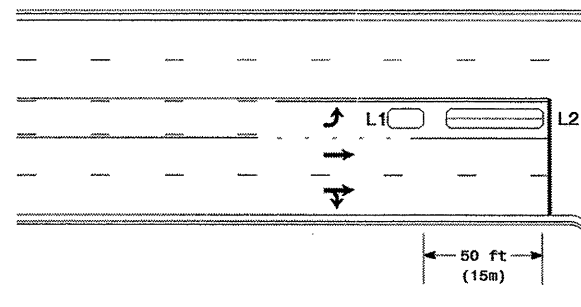

L1 = 6ft X 15ft (1.8m X 4.6m) Queue detector  
L2 = 6ft X 40ft (1.8m X 12.0m) Quadrupole loop

Queue Loop Detection

### Right Turn Lane Detection

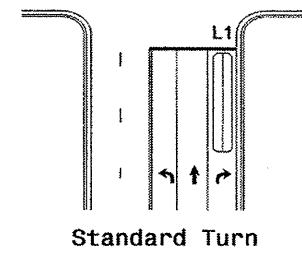

Standard Turn

L1 = 6ft X 40ft (1.8m X 12.0m) Quadrupole loop  
L2 = 6ft X 6ft (1.8m X 1.8m) [Minimum] Presence loop  
Wired separately  
L3 = 6ft X 20ft (1.8m X 6.0m) Quadrupole loop  
Wired in series

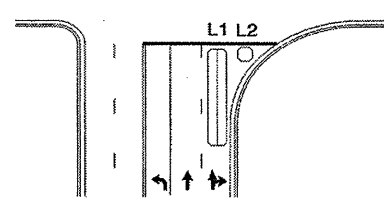

Wide Radius Turn

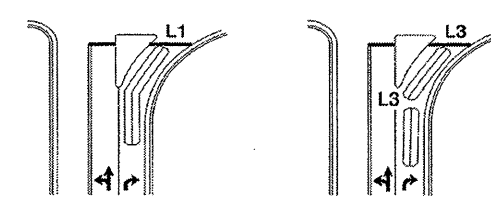

Channelized Turn

### Side Street Detection

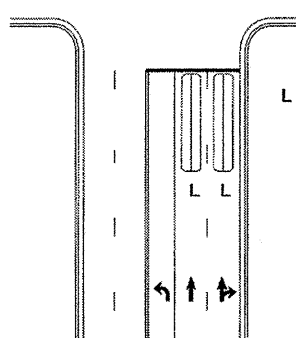

L = 6ft X 40ft (1.8m X 12.0m)  
Quadrupole loop  
Wired to separate  
detectors/channels

Presence Loop Detection

### Presence Loop Placement at Stop Lines

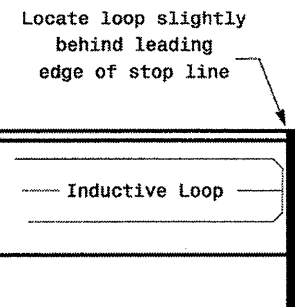

Locate loop slightly  
behind leading  
edge of stop line

Note:  
Loop may be located in advance  
of stop line when stop line is  
greater than 15' (4.5m) from edge  
of intersecting roadway; or, when  
loop detects a permissive or  
protected/permissive left turn.

### Recommended Number of Turns

Single 6' X 6' (1.8m X 1.8m)  
loop (wired separately):

Length of Lead-in ft (m)	Number of Turns
< 250 (75)	3
250-375 (75-115)	4
375-525 (115-160)	5
> 525 (160)	6

Quadrupole loops: Use 2-4-2 turns

6' X 15' (1.8m X 4.6m) Loops:  
Lead-in < 150' (45 m), use 2 turns  
Lead-in > 150' (45 m), use 3 turns

#### Typical Loop Locations

PLAN DATE: June 2006	REVIEWED BY:
PREPARED BY: P. L. Alexander	REVIEWED BY:
SCALE: N/A	DATE: 12/14/06
SIGNATURE: P. L. Alexander	
SIG. INVENTORY NO.:	