

01-0CT-2012 14:41
 P:\Projects\U4412\Taffre\Signing\CADD\VPMP\U4412_PMP_0tues.dgn
 jmartinez AT 12/27/12

T.I.P.: U-4412

CONTRACT: C203036

STATE OF NORTH CAROLINA
DEPARTMENT OF TRANSPORTATION

PAVEMENT MARKING PLAN
HAYWOOD COUNTY

LOCATION: WAYNESVILLE SR 1184 (HOWELL MILL RD) FROM
US-276 (RUSS AVE.) TO US-23 BUSINESS (ASHEVILLE HWY)

TIP NO. U-4412	SHEET NO. PMP-1
APPROVED:	
DATE: 10/1/12	
SEAL	

ROADWAY STANDARD DRAWING

THE FOLLOWING ROADWAY STANDARDS AS APPEAR IN "ROADWAY STANDARD DRAWINGS" -
 PROJECT SERVICES UNIT - N.C. DEPARTMENT OF TRANSPORTATION - RALEIGH, N.C.,
 DATED JANUARY 2012 ARE APPLICABLE TO THIS PROJECT AND BY REFERENCE HEREBY ARE
 CONSIDERED A PART OF THESE PLANS:

STD. NO.	TITLE
1205.01	PAVEMENT MARKINGS - LINE TYPES AND OFFSETS
1205.02	PAVEMENT MARKINGS - TWO-LANE AND MULTILANE ROADWAYS
1205.04	PAVEMENT MARKINGS - INTERSECTIONS
1205.05	PAVEMENT MARKINGS - TURN LANES
1205.07	PAVEMENT MARKINGS - PEDESTRIAN CROSSWALKS
1205.08	PAVEMENT MARKINGS - SYMBOLS AND WORD MESSAGES
1205.09	PAVEMENT MARKINGS - PAINTED ISLANDS
1205.12	PAVEMENT MARKINGS - BRIDGES
1250.01	RAISED PAVEMENT MARKERS - INSTALLATION SPACING
1251.01	RAISED PAVEMENT MARKERS - PERMANENT AND TEMPORARY
1253.01	RAISED PAVEMENT MARKERS - SNOWPLOWABLE
1261.01	GUARDRAIL AND BARRIER DELINEATORS - INSTALLATION SPACING
1261.02	GUARDRAIL AND BARRIER DELINEATORS - TYPES AND MOUNTING
1262.01	GUARDRAIL END DELINEATION

GENERAL NOTES

THE FOLLOWING GENERAL NOTES APPLY AT ALL TIMES FOR THE DURATION OF THE CONSTRUCTION PROJECT, EXCEPT WHEN OTHERWISE NOTED IN THE PLAN, OR DIRECTED BY THE ENGINEER.

A) INSTALL PAVEMENT MARKINGS AND PAVEMENT MARKERS ON THE FINAL SURFACE AS FOLLOWS:

ROAD NAME	MARKING	MARKER
ALL	THERMOPLASTIC	SNOWPLOWABLE

B) TYPE III COLD APPLIED PLASTIC MAY BE USED IN LIEU OF TYPE II COLD APPLIED PLASTIC. IF TYPE III COLD APPLIED PLASTIC IS USED, IT SHALL BE PAID FOR USING THE TYPE II COLD APPLIED PLASTIC PAY ITEM.

C) TIE PROPOSED PAVEMENT MARKING LINES TO EXISTING PAVEMENT MARKING LINES.

D) REMOVE/REPLACE ANY CONFLICTING/DAMAGED PAVEMENT MARKINGS AND MARKERS.

E) PASSING ZONES WILL BE DETERMINED IN THE FIELD AND MUST BE APPROVED BY THE ENGINEER.

F) STOP BAR LOCATION AT NON-SIGNALIZED INTERSECTIONS MAY BE ADJUSTED AS DIRECTED BY THE ENGINEER.

G) REMOVE ALL RESIDUE AND SURFACE LAITANCE BY ACCEPTABLE METHODS ON THE CONCRETE SURFACES PRIOR TO PLACING THERMOPLASTIC PAVEMENT MARKING MATERIAL.

H) ON ASPHALT SURFACES, USE HEATED-IN-PLACE THERMOPLASTIC OR EXTRUDED THERMOPLASTIC FOR STOP BARS, SYMBOLS, CHARACTERS AND DIAGONALS.

I) ON CONCRETE SURFACES, USE HEATED-IN-PLACE THERMOPLASTIC OR COLD APPLIED PLASTIC FOR STOP BARS, SYMBOLS, CHARACTERS AND DIAGONALS.

J) MARKERS SHALL BE INSTALLED ACCORDING TO THE NCDOT ROADWAY STANDARD DRAWING 1250.01.

INDEX

SHEET NO.	DESCRIPTION
PMP-1	PAVEMENT MARKING PLAN TITLE
PMP-2	PAVEMENT MARKING SCHEDULE
PMP-3	CROSSWALK AND STOP BAR PAVEMENT MARKING DETAIL
PMP-4-9	PAVEMENT MARKING DETAIL

PLAN PREPARED BY: N.C.D.O.T. SIGNING AND DELINEATION UNIT

K. L. JORDAN SIGNING & DELINEATION REGIONAL ENGINEER
 J. G. MARTINEZ SIGNING & DELINEATION PROJECT DESIGN ENGINEER

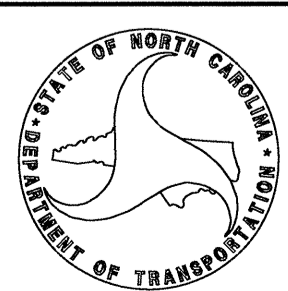

TIP NO.	SHEET NO.
U-4412	PMP-2
APPROVED: <i>[Signature]</i>	
DATE: 10/1/12	
SEAL	



PAVEMENT MARKING SCHEDULE

SYMBOL	DESCRIPTION	FINAL PAVEMENT MARKINGS
T10	3 FT. - 3 FT./SP WHITE MINISKIP	THERMOPLASTIC(12", 120 MILS)
T2	WHITE STOPBAR	THERMOPLASTIC(24", 120 MILS)
T3	WHITE CROSSWALK LINE	
T8	2 FT. - 6 FT./SP WHITE MINISKIP	THERMOPLASTIC(4", 120 MILS)
TD	3 FT. - 9 FT./SP WHITE MINISKIP	
TE	WHITE SOLID LANE LINE	
TF	10 FT. YELLOW SKIP	
TI	YELLOW DOUBLE CENTER	
TA	WHITE EDGELINE	THERMOPLASTIC(4", 90 MILS)
TB	YELLOW EDGELINE	
TQ	WHITE CROSSWALK LINE	THERMOPLASTIC(8", 120 MILS)
		THERMOPLASTIC(8", 90 MILS)
TP	YELLOW DIAGONAL	
UI	ALPHANUMERIC CHAR.	THERMOPLASTIC PAVEMENT MARKING CHARACTER (120 MILS)
UA	LEFT TURN ARROW	THERMOPLASTIC PAVEMENT MARKING SYMBOLS (90 MILS)
UB	RIGHT TURN ARROW	
UE	COMBO. STRAIGHT/RIGHT	
UN	24" YIELD LINE TRIANGLE	
SYMBOL	DESCRIPTION	MARKERS
MB	CRYSTAL & RED	PERMANENT RAISED PAVEMENT MARKERS
ME	YELLOW & YELLOW	SNOWPLOWABLE RAISED PAVEMENT MARKERS

01-OCT-2012 14:42
 P:\Tpp\Projects\11\4412\Traffic\Signing\CADD\PMP\U4412.PMP_01tes.dgn
 jsmartinez AT 1E247795

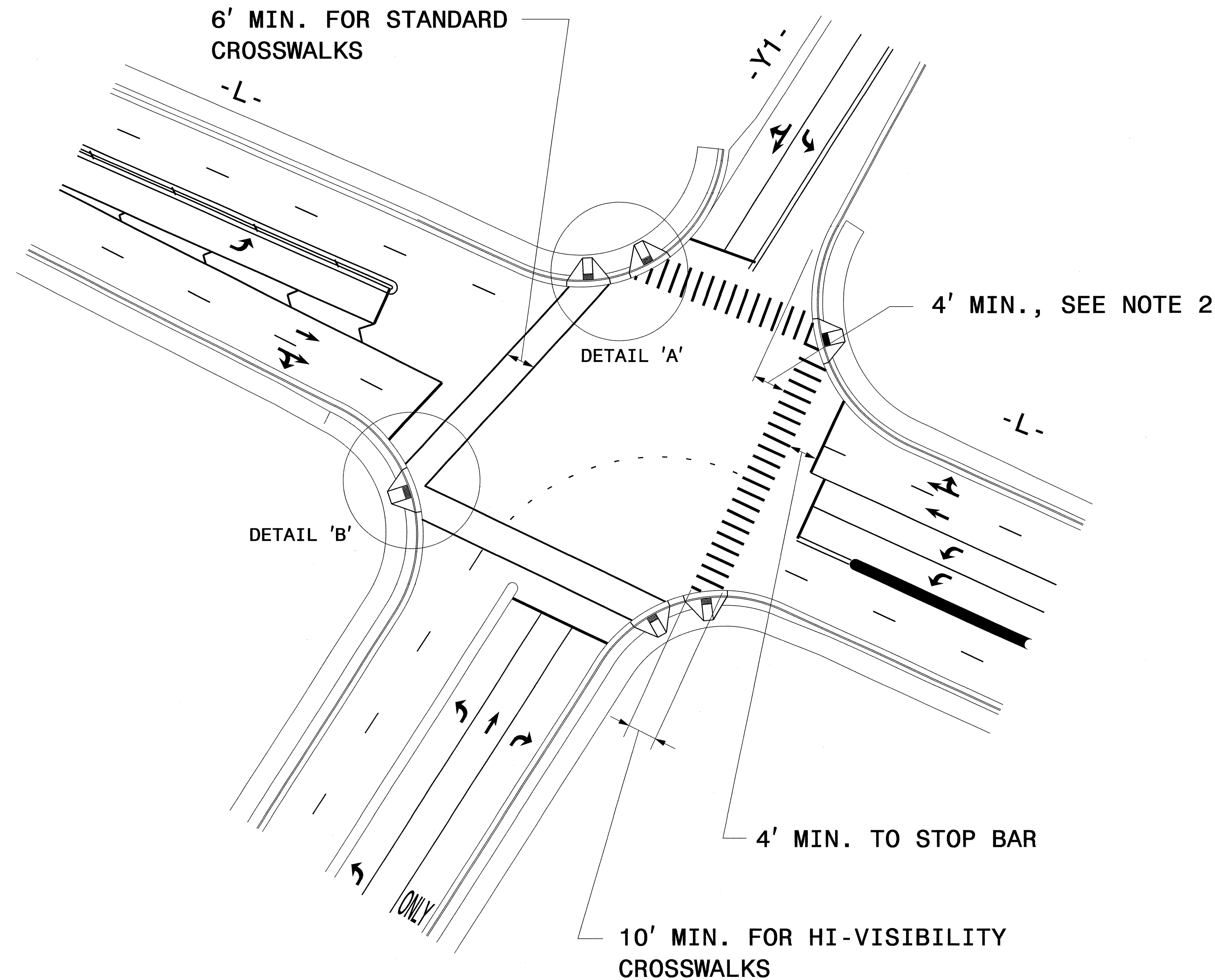

GUIDANCE DETAIL FOR STANDARD AND HI-VISIBILITY CROSSWALKS AT SIGNALIZED OR STOP SIGN CONTROLLED INTERSECTIONS

1. USE DETAILS ABOVE AND THE FOLLOWING NOTES FOR GUIDANCE IN PLACING CROSSWALKS AND STOP BARS NOT STATIONED ON THE DETAIL SHEETS OR WHEN FIELD ADJUSTMENTS REQUIRED MOVING STATIONED MARKINGS AS DIRECTED BY THE ENGINEER. REFER TO NCDOT ROADWAY STANDARD DRAWINGS, MUTCD AND ADA STANDARDS FOR ADDITIONAL GUIDANCE.
2. SET BACK DISTANCE FROM INSIDE CROSSWALK MARKING TO NEAREST EDGE OF TRAVEL IS 4' MIN.
3. BEYOND THE CURB FACE, A CLEAR SPACE OF 4' X 4' MINIMUM SHALL BE PROVIDED WITHIN THE WIDTH OF THE CROSSWALK.
4. SINGLE DIAGONAL CURB RAMPS WITH FLARED SIDES SHALL HAVE A SEGMENT OF CURB 2 FEET LONG MINIMUM LOCATED ON EACH SIDE OF THE CURB RAMP AND WITHIN THE MARKED CROSSING, SEE DETAIL 'B'.
5. CURB RAMPS SHALL BE CONSTRUCTED IN ACCORDANCE TO THE LATEST NCDOT ROADWAY STANDARD DRAWINGS.

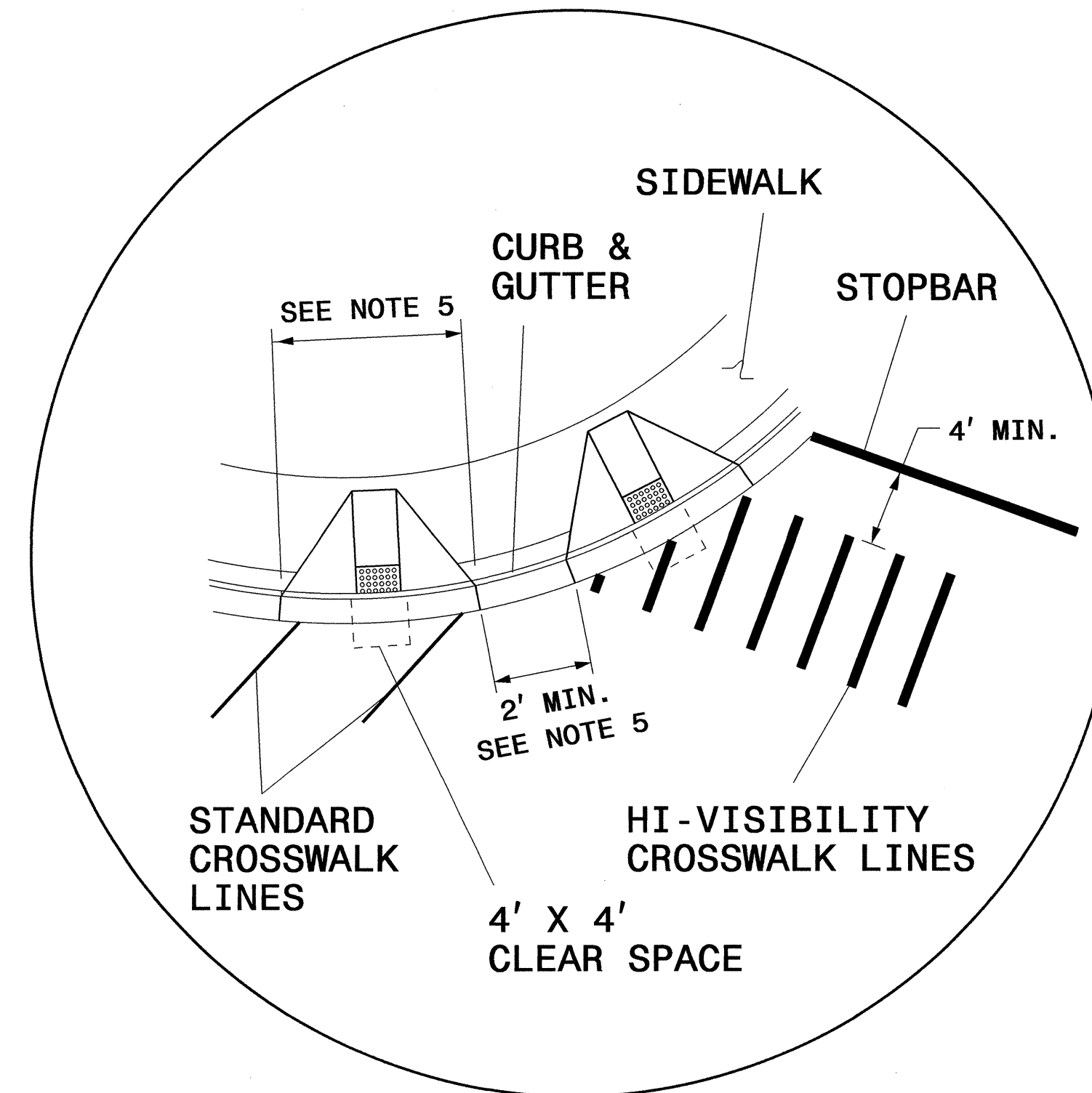

DETAIL 'A'- DUAL CURB RAMPS

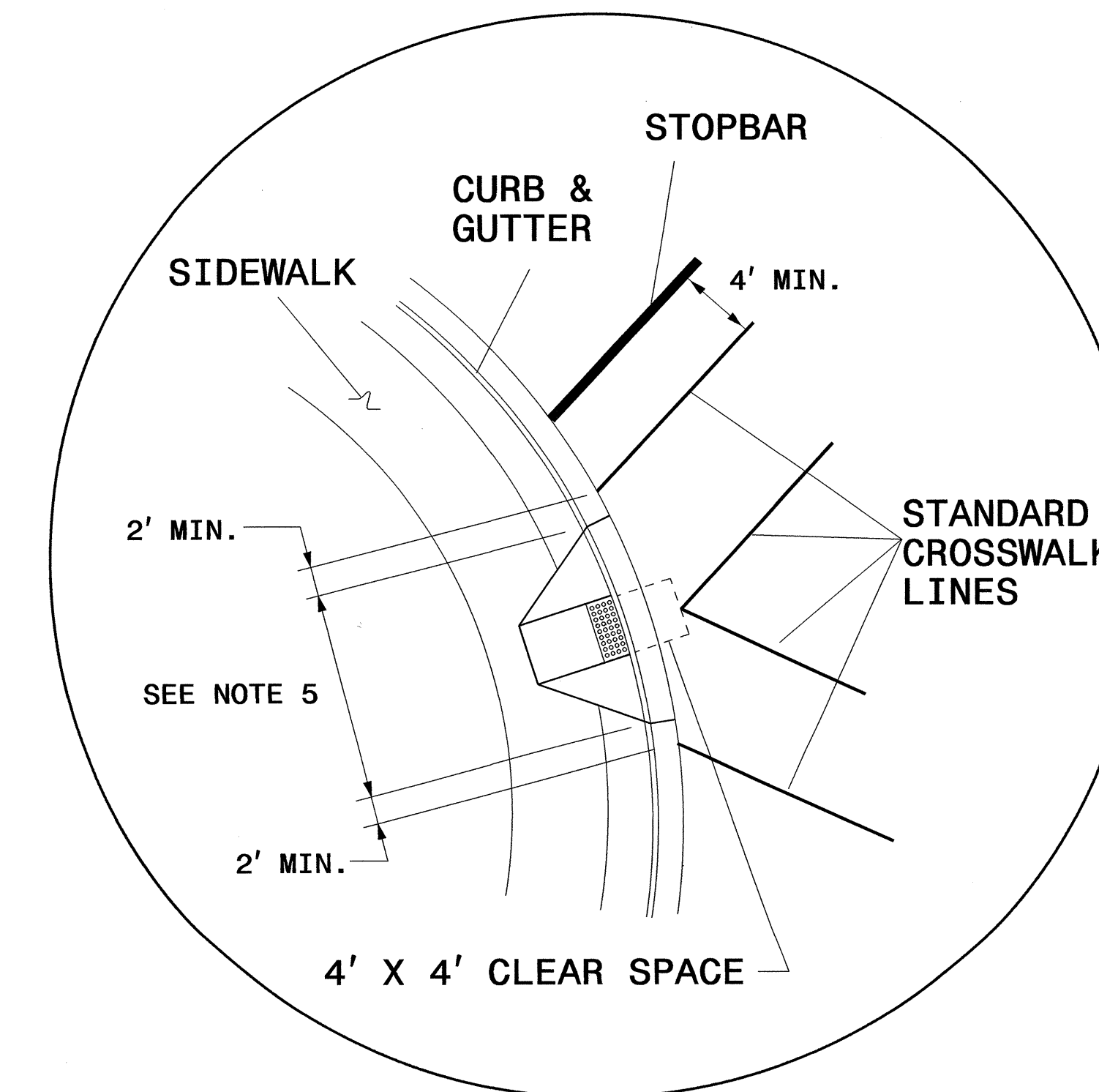

DETAIL 'B'- SINGLE DIAGONAL CURB RAMP

CROSSWALK AND STOP BAR PAVEMENT MARKING DETAIL

TIP NO. U-4412	SHEET NO. PMP-4
APPROVED: <i>[Signature]</i>	
DATE: 10/1/12	
SEAL	

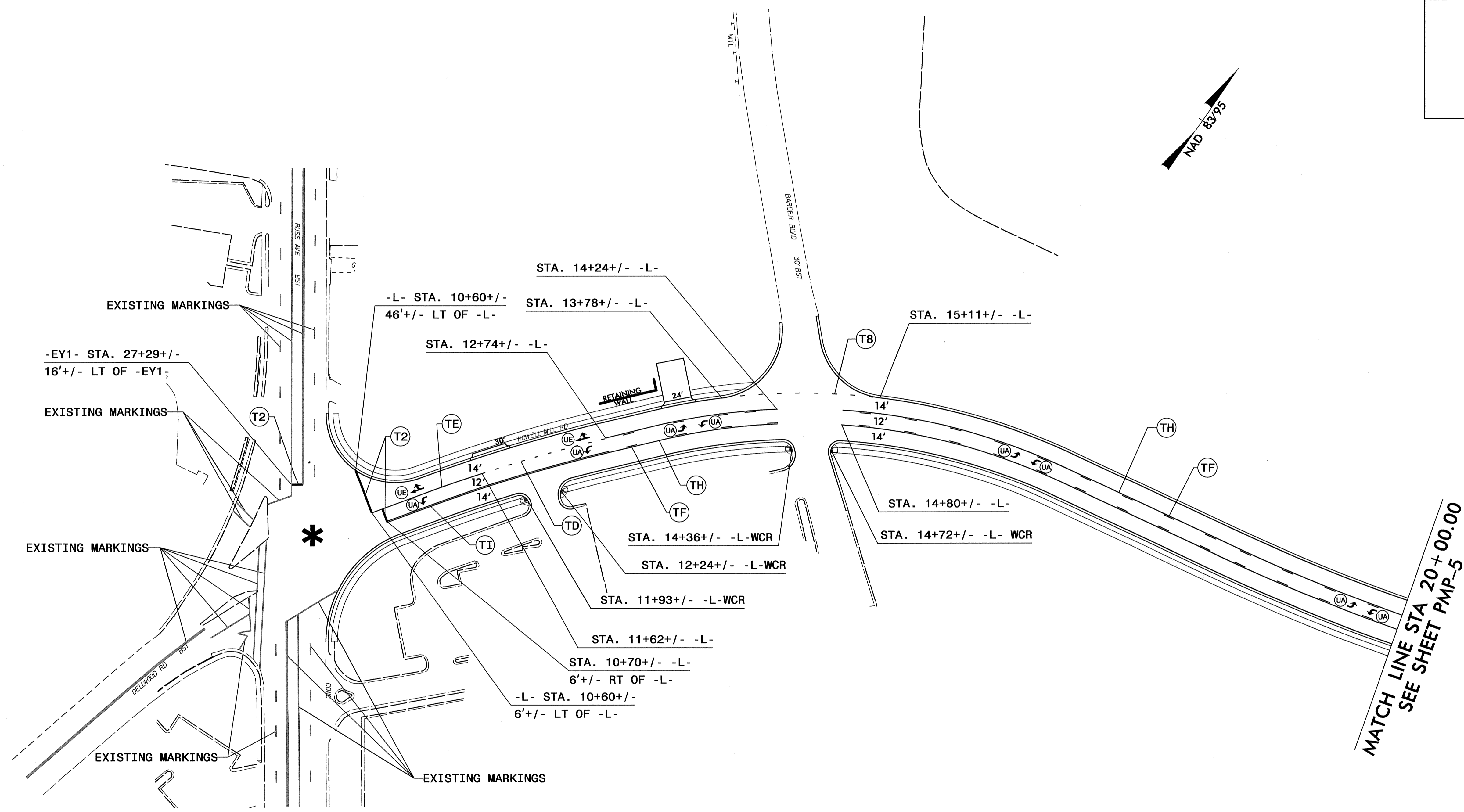

PROJECT NOTES

- T2 WHITE STOP BAR (24", 120 MIL)
- T8 2FT.-6FT./SP WHITE MINISKIP (4", 120 MIL)
- TD 3FT.-9FT./SP WHITE MINISKIP (4", 120 MIL)
- TE WHITE SOLID LANE LINE (4", 120 MIL)
- TF 10FT. YELLOW SKIP (4", 120 MIL)
- TH YELLOW SINGLE CENTER (4", 120 MIL)
- TI YELLOW DOUBLE CENTER (4", 120 MIL)
- UA LEFT TURN ARROW (90 MIL)
- UE COMBO RIGHT/STRAIGHT ARROW (90 MIL)

* SIGNALIZED

**HOWELL MILL RD
PAVEMENT MARKING DETAIL**

B:\00T-2012\14441\144412\Traffic\Signing\CADD\PMMP\U4412_Sgn_PMP_04.dgn
 10/1/12 10:56:51 AM

TIP NO. U-4412	SHEET NO. PMP-5
APPROVED: <i>RW</i>	DATE: 10/1/12
SEAL	

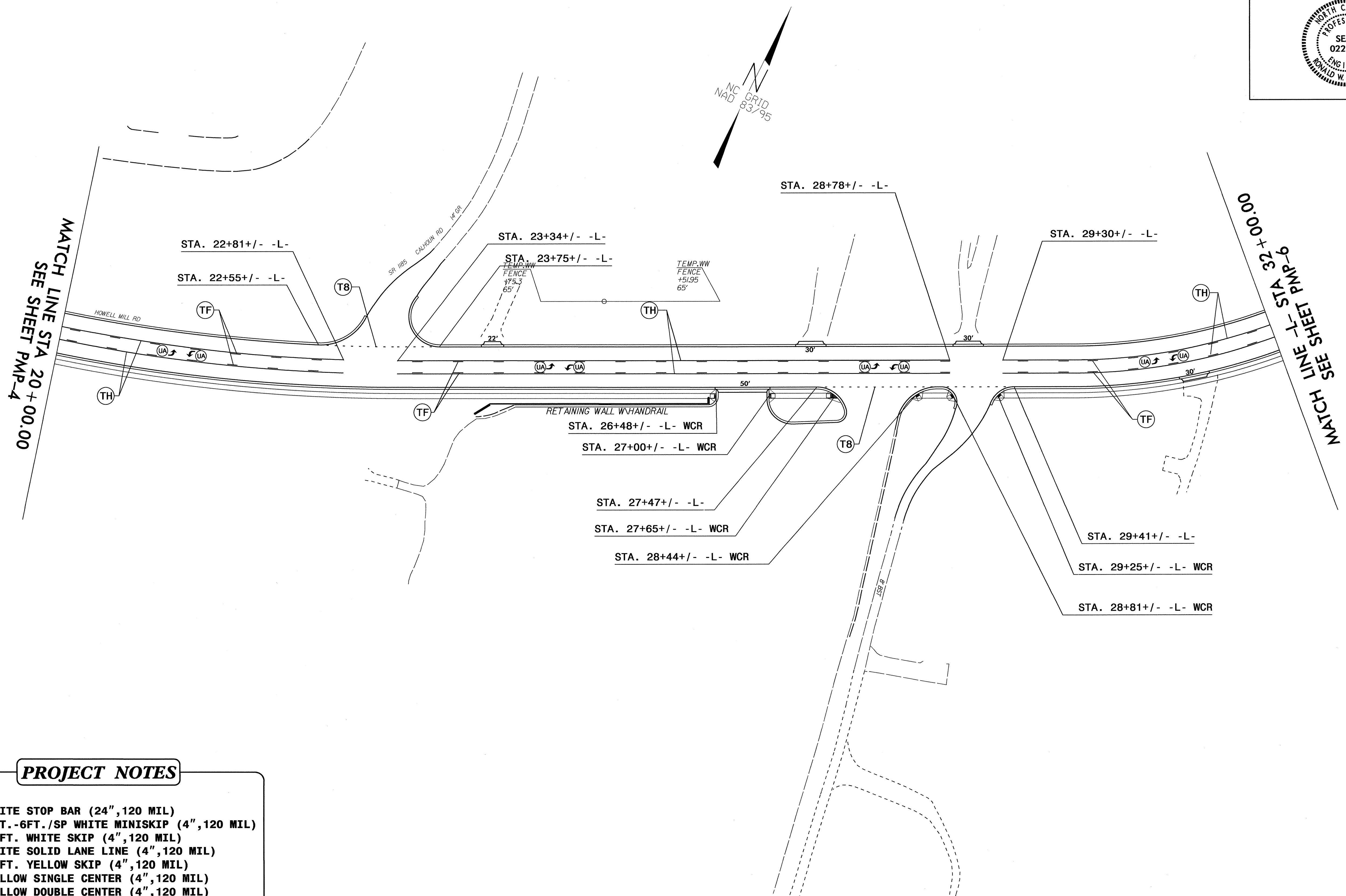

PROJECT NOTES

- T2 WHITE STOP BAR (24", 120 MIL)
- T8 2FT.-6FT./SP WHITE MINISKIP (4", 120 MIL)
- TC 10FT. WHITE SKIP (4", 120 MIL)
- TE WHITE SOLID LANE LINE (4", 120 MIL)
- TF 10FT. YELLOW SKIP (4", 120 MIL)
- TH YELLOW SINGLE CENTER (4", 120 MIL)
- TI YELLOW DOUBLE CENTER (4", 120 MIL)
- UA LEFT TURN ARROW (90 MIL)
- UE COMBO RIGHT/STRAIGHT ARROW (90 MIL)

**HOWELL MILL RD
PAVEMENT MARKING DETAIL**

01-OCT-2012 14:45
 P:\01\Projects\U4412\Traffic\Signing\CADD\PMU\U4412_Sgn_PMP_05.dgn
 jgmar-tinez AT 12/24/12

TIP NO. U-4412	SHEET NO. PMP-6
APPROVED: <i>R.W.K.</i>	
DATE: 10/1/12	
SEAL	

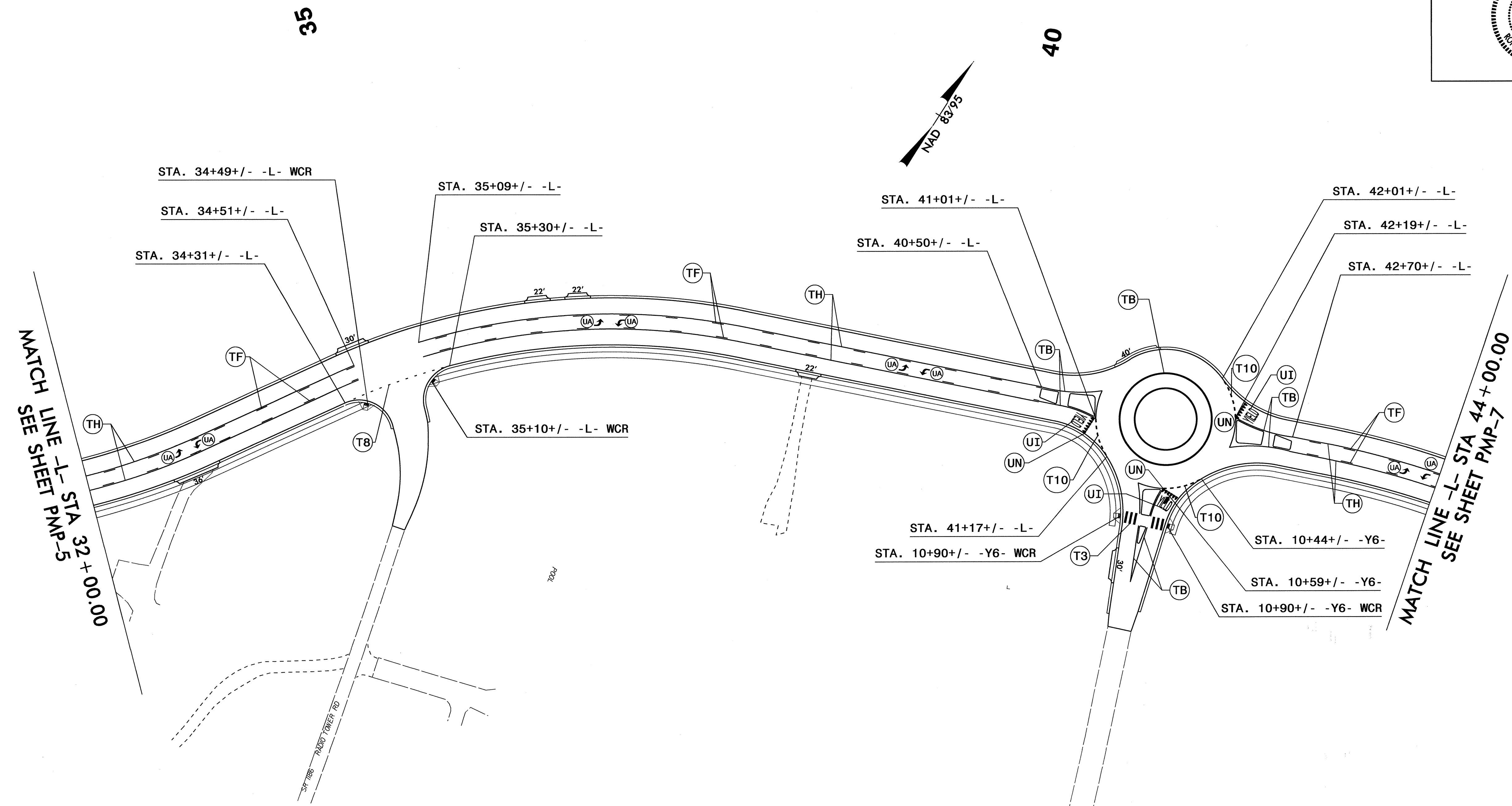

PROJECT NOTES

- T3 WHITE CROSSWALK LINE (24", 120 MIL)
- T8 2FT.-6FT./SP WHITE MINISKIP (4", 120 MIL)
- T10 3FT.-3FT./SP WHITE MINISKIP (12", 120 MIL)
- TB YELLOW EDGELINE (4", 90 MIL)
- TF 10FT. YELLOW SKIP (4", 120 MIL)
- TH YELLOW SINGLE CENTER (4", 120 MIL)
- UA LEFT TURN ARROW
- UI ALPHANUMERIC CHAR.
- UN 24" YIELD LINE TRIANGLE

**HOWELL MILL RD
PAVEMENT MARKING DETAIL**

C:\Users\jgmar-tinez\Documents\Projects\U4412\Traffic\Signing\CADD\VPMP\U4412_Sgn_PMP_06.dgn
 10/1/12 10:46 AM
 jgmar-tinez

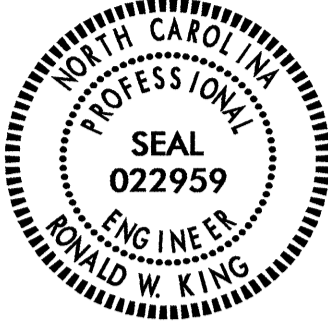
TIP NO. U-4412	SHEET NO. PMP-7
APPROVED: <i>[Signature]</i>	
DATE: 10/1/12	
SEAL	
	



MATCH LINE -L- STA 44+00.00
SEE SHEET PMP-6

MATCH LINE -L- STA 58+00.00
SEE SHEET PMP-8

PROJECT NOTES

- T8 2FT.-6FT./SP WHITE MINISKIP (4")
- TF 10FT. YELLOW SKIP (4")
- TH YELLOW SINGLE CENTER (4")
- UA LEFT TURN ARROW

**HOWELL MILL RD
PAVEMENT MARKING DETAIL**

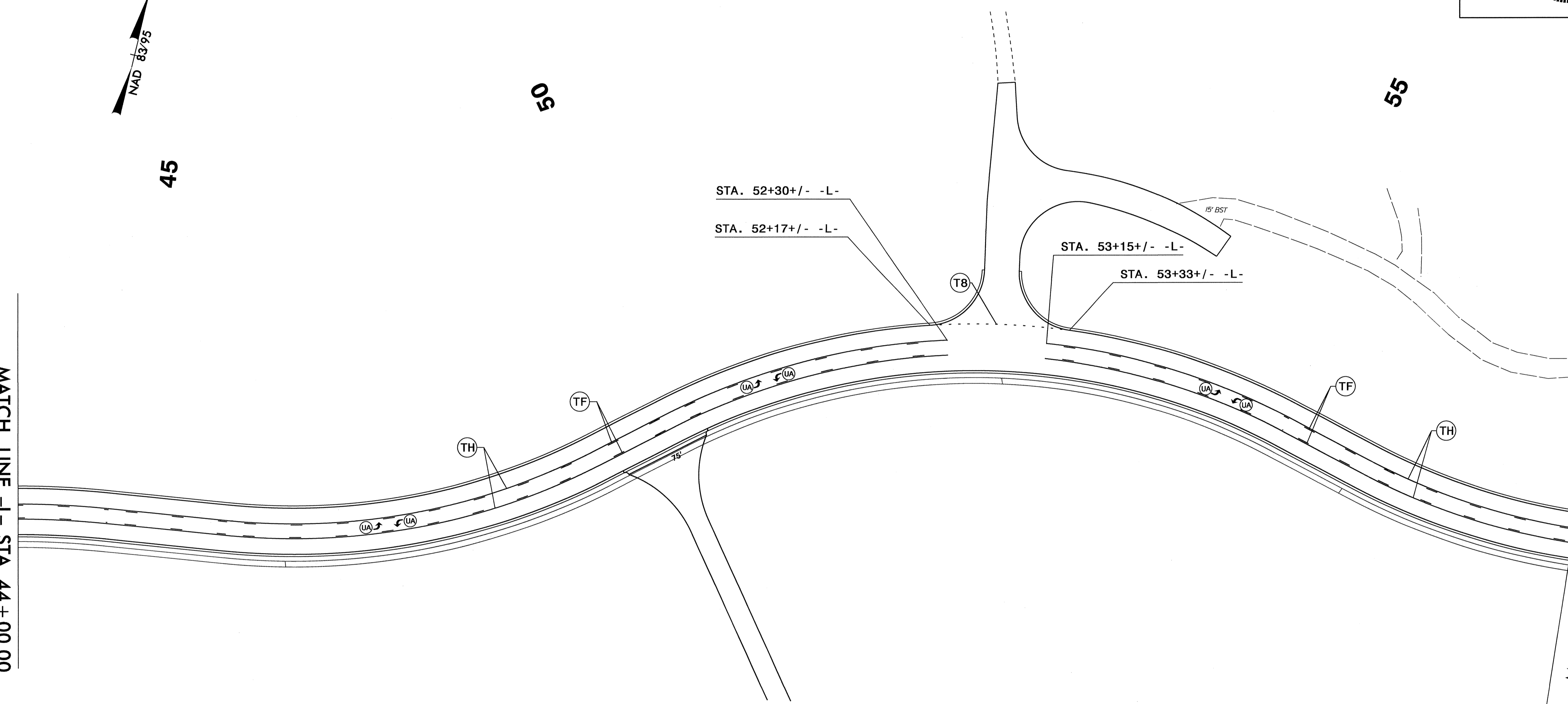

01-001-2012 14:47
L:\pmp\proj\4412\Taffre\Signing\CADD\PM\U4412_Sgn_PMP_07.dgn
L:\pmp\proj\4412\Taffre\Signing\CADD\PM\U4412_Sgn_PMP_07.dgn

TIP NO. U-4412	SHEET NO. PMP-8
APPROVED: <i>[Signature]</i>	
DATE: 6/6/13	
SEAL	

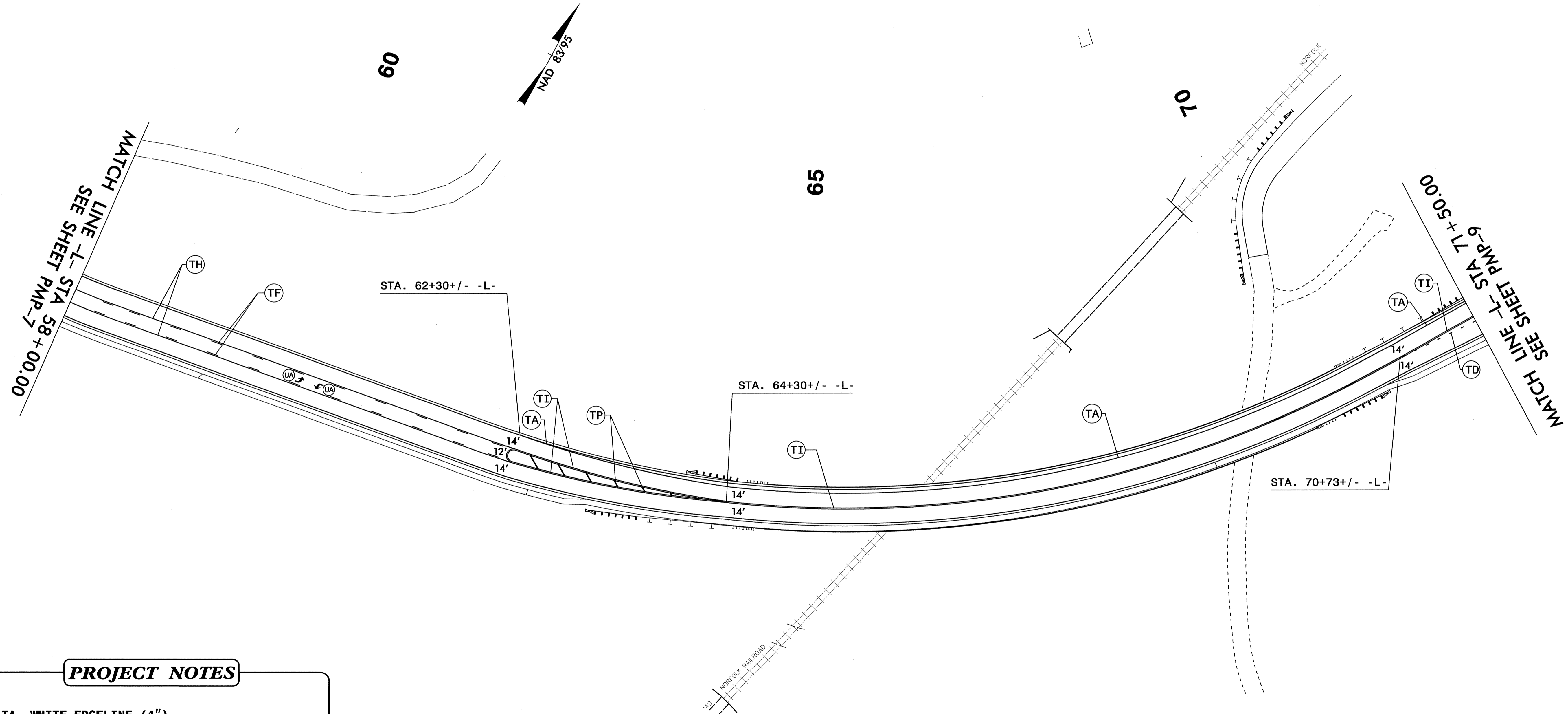

PROJECT NOTES

- TA WHITE EDGELINE (4")
- TF 10FT. YELLOW SKIP (4")
- TH YELLOW SINGLE CENTER (4")
- TI YELLOW DOUBLE CENTER (4")
- TP YELLOW DIAGONAL (8")
- UA LEFT TURN ARROW

**HOWELL MILL RD
PAVEMENT MARKING DETAIL**

05: JUN-2013 10:58
 P:\Projects\4412\Traffic\Signing\CADD\PMP\U4412_Sgn_PMP_08.dgn
 Jamar.tinez AT TE247796

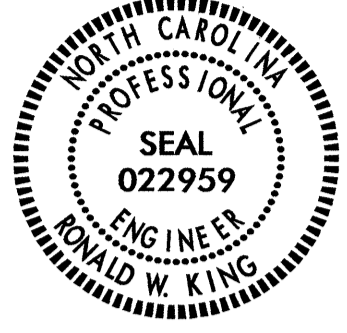
TIP NO. U-4412	SHEET NO. PMP-9
APPROVED: <i>[Signature]</i>	
DATE: 6/6/13	
SEAL	
	

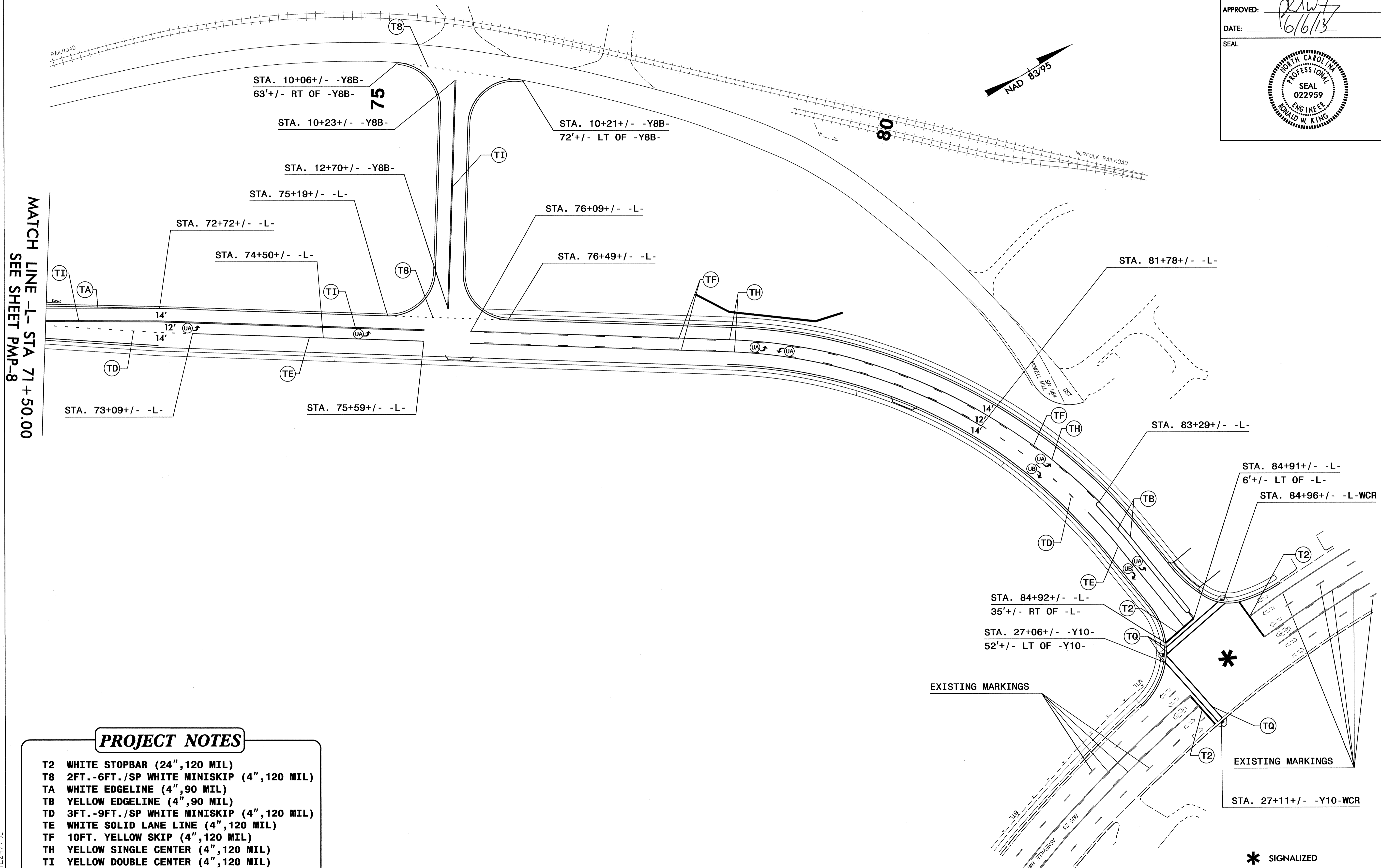

MATCH LINE -L- STA 71+50.00
SEE SHEET PMP-8

PROJECT NOTES

- T2 WHITE STOPBAR (24", 120 MIL)
- T8 2FT.-6FT./SP WHITE MINISKIP (4", 120 MIL)
- TA WHITE EDGELINE (4", 90 MIL)
- TB YELLOW EDGELINE (4", 90 MIL)
- TD 3FT.-9FT./SP WHITE MINISKIP (4", 120 MIL)
- TE WHITE SOLID LANE LINE (4", 120 MIL)
- TF 10FT. YELLOW SKIP (4", 120 MIL)
- TH YELLOW SINGLE CENTER (4", 120 MIL)
- TI YELLOW DOUBLE CENTER (4", 120 MIL)
- TP YELLOW DIAGONAL (8", 90 MIL)
- TQ WHITE CROSSWALK LINE (8", 120 MIL)
- UA LEFT TURN ARROW
- UB RIGHT TURN ARROW

**HOWELL MILL RD
PAVEMENT MARKING DETAIL**

6/6/13 10:57 AM U:\4412\Traffic\Signing\CADD\PM\U4412_Sgn_PMP_09.dgn
User: dking