

T.I.P.: I-4733

CONTRACT: C203203

STATE OF NORTH CAROLINA
DEPARTMENT OF TRANSPORTATION

PAVEMENT MARKING PLAN
MECKLENBURG COUNTY

LOCATION: CORNELIUS, MODIFY INTERCHANGE AT
I-77 AND SR 5544 (W CATAWBA AVE)

TIP NO. SHEET NO.
I-4733 PMP-1

APPROVED: [Signature]
DATE: 5/17/13



GENERAL NOTES

THE FOLLOWING GENERAL NOTES APPLY AT ALL TIMES FOR THE DURATION OF THE CONSTRUCTION PROJECT, EXCEPT WHEN OTHERWISE NOTED IN THE PLAN, OR DIRECTED BY THE ENGINEER.

A) INSTALL PAVEMENT MARKINGS AND PAVEMENT MARKERS ON THE FINAL SURFACE AS FOLLOWS:

Table with 3 columns: ROAD NAME, MARKING, MARKER. Rows include ALL ROADS, BRIDGE, THERMOPLASTIC, COLD APPLIED PLASTIC, RAISED, RAISED.

B) TYPE III COLD APPLIED PLASTIC MAY BE USED IN LIEU OF TYPE II COLD APPLIED PLASTIC. IF TYPE III COLD APPLIED PLASTIC IS USED, IT SHALL BE PAID FOR USING THE TYPE II COLD APPLIED PLASTIC PAY ITEM.

C) TIE PROPOSED PAVEMENT MARKING LINES TO EXISTING PAVEMENT MARKING LINES.

D) REMOVE/REPLACE ANY CONFLICTING/DAMAGED PAVEMENT MARKINGS AND MARKERS.

E) PASSING ZONES WILL BE DETERMINED IN THE FIELD AND MUST BE APPROVED BY THE ENGINEER.

F) STOP BAR LOCATION AT NON-SIGNALIZED INTERSECTIONS MAY BE ADJUSTED AS DIRECTED BY THE ENGINEER.

G) REMOVE ALL RESIDUE AND SURFACE LAITANCE BY ACCEPTABLE METHODS ON THE CONCRETE SURFACES PRIOR TO PLACING COLD APPLIED PLASTIC PAVEMENT MARKING MATERIAL.

H) ON ASPHALT SURFACES, USE HEATED-IN-PLACE THERMOPLASTIC OR EXTRUDED THERMOPLASTIC FOR STOP BARS, SYMBOLS, CHARACTERS AND DIAGONALS.

ROADWAY STANDARD DRAWINGS

THE FOLLOWING ROADWAY STANDARDS AS APPEAR IN "ROADWAY STANDARD DRAWINGS" - PROJECT SERVICES UNIT - N.C. DEPARTMENT OF TRANSPORTATION - RALEIGH, N.C., DATED JANUARY 2012 ARE APPLICABLE TO THIS PROJECT AND BY REFERENCE HEREBY ARE CONSIDERED A PART OF THESE PLANS:

Table with 2 columns: STD. NO., TITLE. Lists drawing standards such as 1205.01 PAVEMENT MARKINGS - LINE TYPES & OFFSETS, 1205.02 PAVEMENT MARKINGS - 2 LANE & MULTILANE ROADWAYS, etc.

FINAL PAVEMENT MARKING SCHEDULE

Table with 3 columns: SYMBOL, DESCRIPTION, PAY ITEM. Lists marking items like C13 3 FT-9 FT/SP WHITE MINISKIP (8"), CA WHITE EDGELINE (4"), CC 10 FT WHITE SKIP (4"), etc.

INDEX

Table with 2 columns: SHEET NO., DESCRIPTION. Lists sheet references like PMP-1 PAVEMENT MARKING PLAN TITLE AND SCHEDULE SHEET, PMP-1A CROSSWALK AND STOP BAR PAVEMENT MARKING DETAIL, etc.

PLAN REVIEWED BY: N.C.D.O.T. SIGNING AND DELINEATION UNIT

KELVIN JORDAN SIGNING & DELINEATION REGIONAL ENGINEER
WALTER JOHNSON SIGNING & DELINEATION DESIGN ENGINEER



PLAN PREPARED BY:

BETSY L. WATSON, P.E. TRAFFIC ENGINEER
ROSI R. HENNEIN TRANSPORTATION TECHNICIAN



Stantec Consulting Services Inc.
901 Jones Franklin Road
Suite 300
Raleigh, NC 27606
Tel. (919) 851-6886
Fax. (919) 851-7024
www.stantec.com
License No. F-0672

TIP NO. I-4733	SHEET NO. PMP-1A
APPROVED: <i>[Signature]</i>	DATE: 6/17/13
SEAL	
	
REVISIONS	

UNLESS OTHERWISE SPECIFIED,  
HI-VISIBILITY CROSSWALK  
MARKINGS SHALL BE USED AT  
MID-BLOCK CROSSINGS

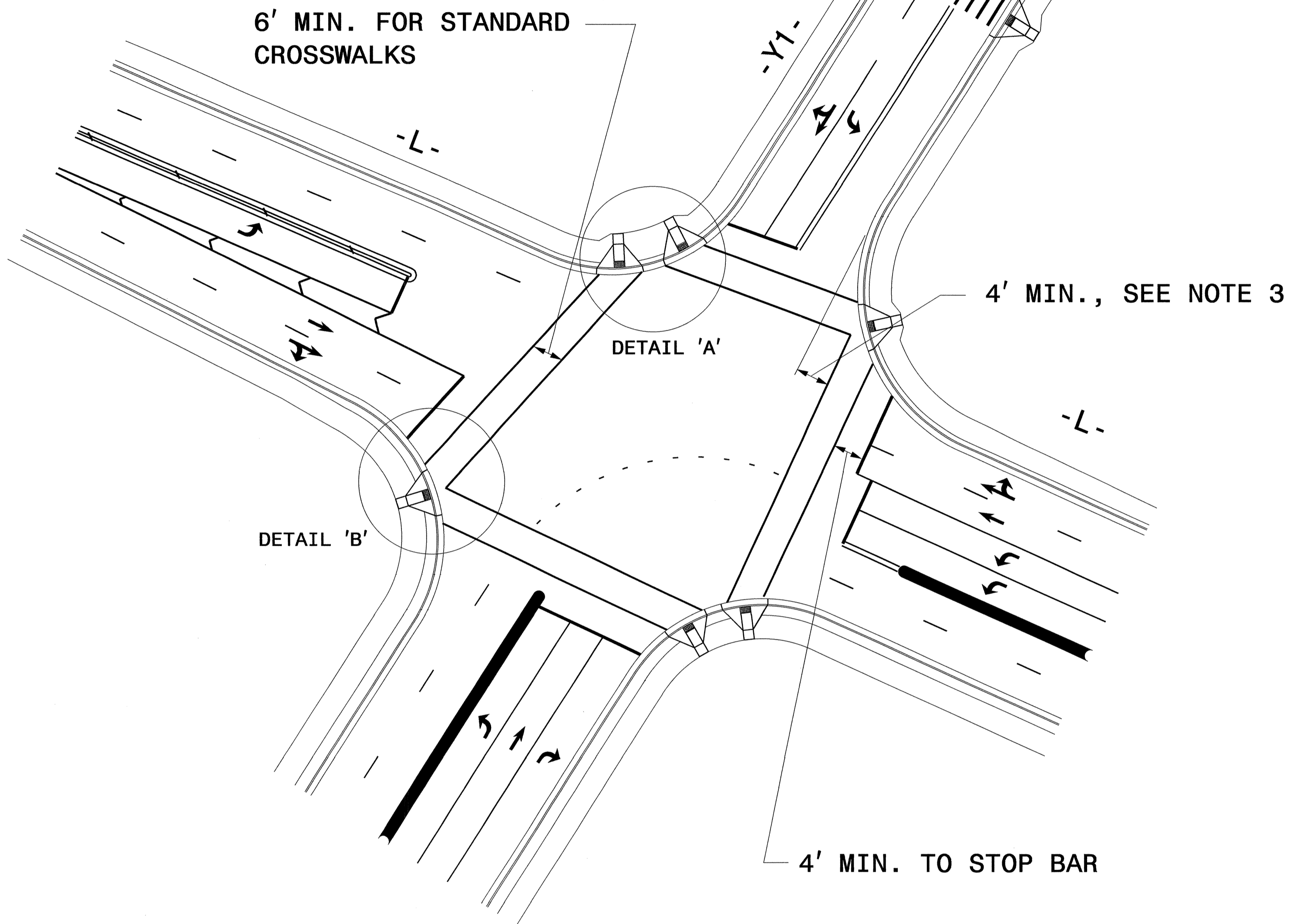

**GUIDANCE DETAIL FOR CROSSWALK MARKINGS**

**NOTES:**

1. USE THE DETAILS ABOVE AND THE FOLLOWING NOTES FOR GUIDANCE IN PLACING CROSSWALK MARKINGS NOT STATIONED ON THE DETAIL SHEETS OR WHEN FIELD ADJUSTMENTS REQUIRED MOVING STATIONED MARKINGS AS DIRECTED BY THE ENGINEER. REFER TO NCDOT ROADWAY STANDARD DRAWINGS, MUTCD AND ADA STANDARDS FOR ADDITIONAL GUIDANCE.
2. THE CROSSWALK MARKINGS SHOWN ON THE ABOVE DETAILS ARE FOR REFERENCE ONLY. ONLY INSTALL CROSSWALK MARKINGS WHERE SHOWN ON THE DETAIL SHEETS OR AS DIRECTED BY THE ENGINEER. THE CROSSWALK MARKING TYPE, STANDARD OR HI-VISIBILITY, SHALL BE INSTALL AS SPECIFIED ON THE DETAIL SHEETS OR AS DIRECTED BY THE ENGINEER.
3. SET BACK DISTANCE FROM INSIDE CROSSWALK MARKING TO NEAREST EDGE OF TRAVEL IS 4' MIN.
4. BEYOND THE BOTTOM GRADE BRAKE, A CLEAR SPACE OF 4' X 4' MINIMUM SHALL BE PROVIDED WITHIN THE MARKINGS.
5. SINGLE DIAGONAL CURB RAMPS WITH FLARED SIDES SHALL HAVE A SEGMENT OF CURB 2 FEET LONG MINIMUM LOCATED ON EACH SIDE OF THE CURB RAMP AND WITHIN THE MARKED CROSSING, SEE DETAIL 'B'.
6. CURB RAMPS SHALL BE CONSTRUCTED IN ACCORDANCE TO THE LATEST NCDOT ROADWAY STANDARD DRAWINGS.

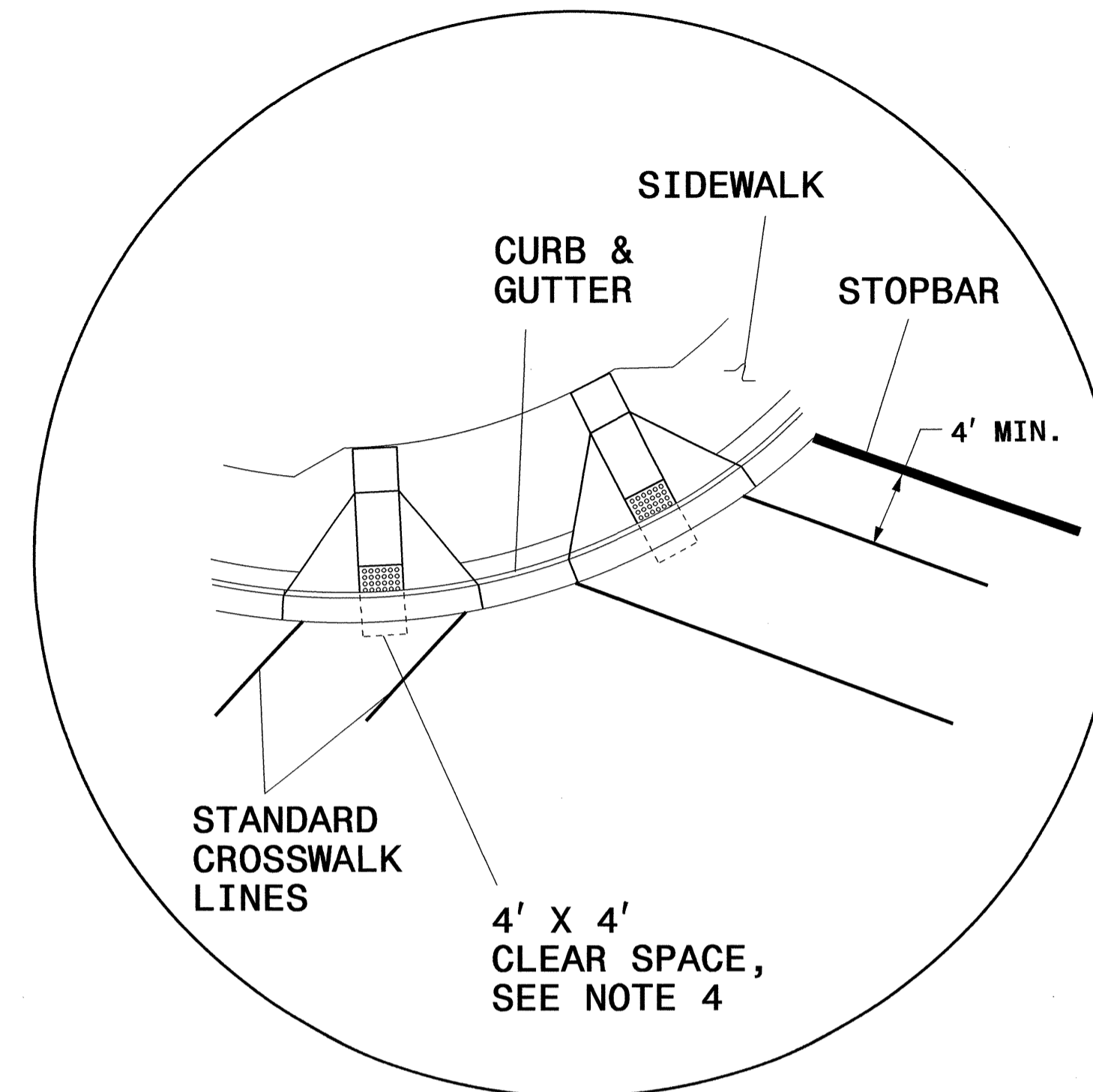

**DETAIL 'A'- DUAL CURB RAMPS**

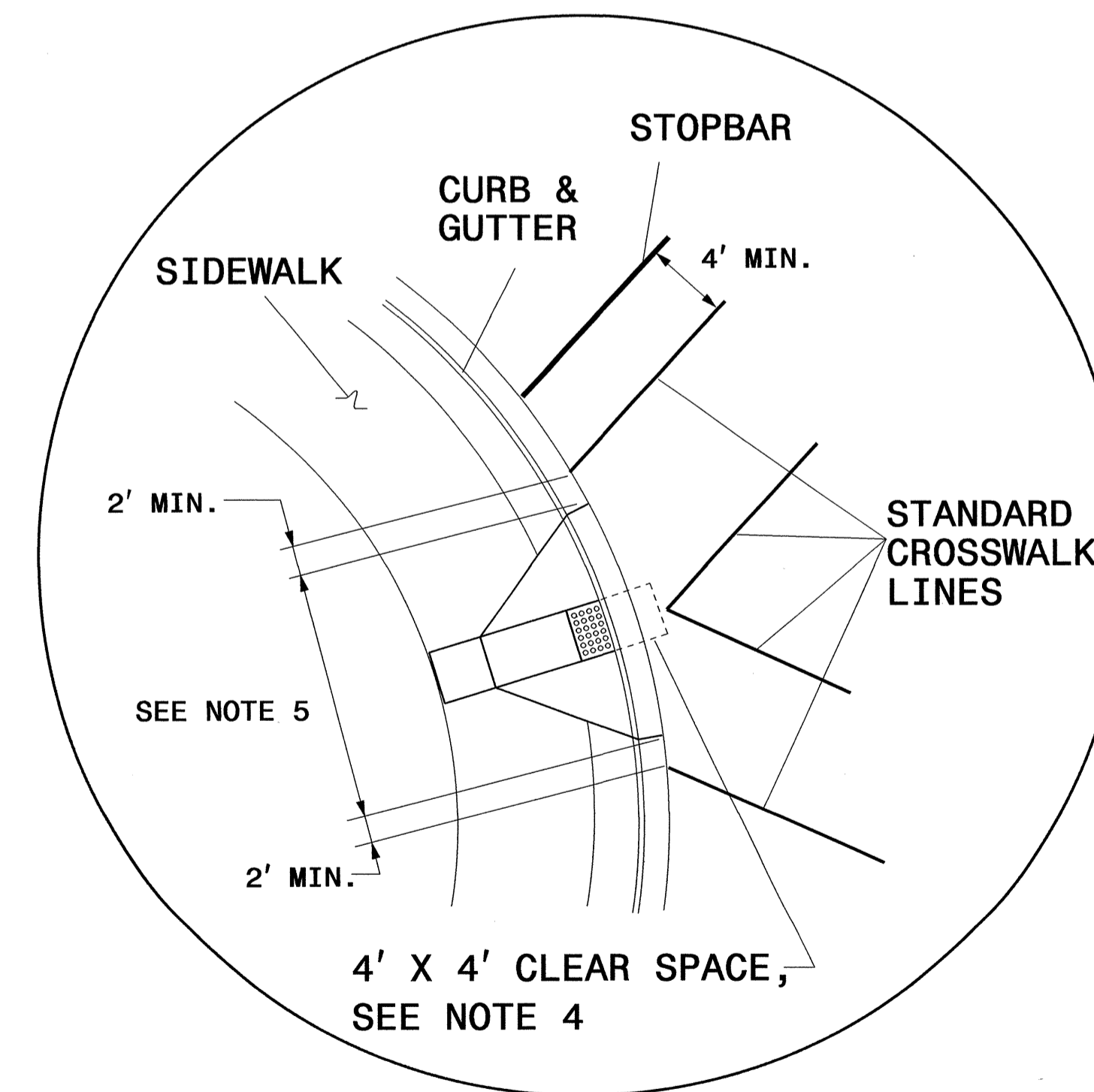

**DETAIL 'B'- SINGLE DIAGONAL CURB RAMP**

**CROSSWALK PAVEMENT MARKING  
GUIDANCE DETAIL**

TIP NO. I-4733	SHEET NO. PMP-1B
APPROVED: <i>RWT</i>	
DATE: 3/6/12	
SEAL	

STATE OF NORTH CAROLINA  
 DEPT. OF TRANSPORTATION  
 DIVISION OF HIGHWAYS  
 RALEIGH, N.C.

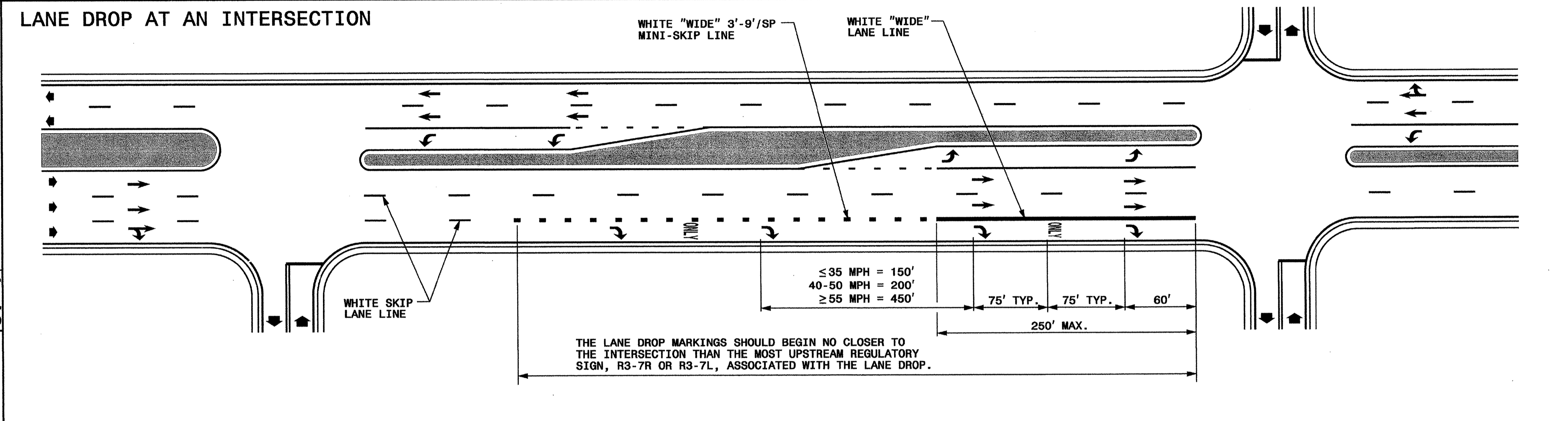

STATE OF NORTH CAROLINA  
 DEPT. OF TRANSPORTATION  
 DIVISION OF HIGHWAYS  
 RALEIGH, N.C.

ENGLISH DETAIL DRAWING FOR  
 PAVEMENT MARKINGS  
 LANE DROPS

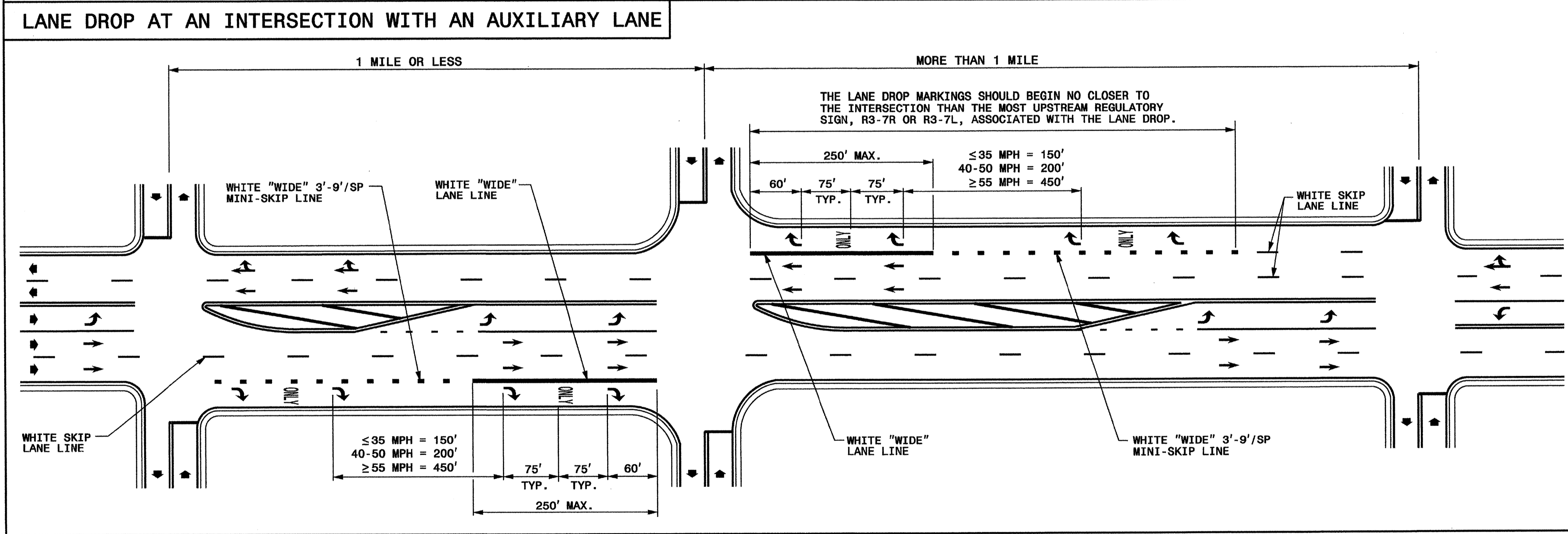

ENGLISH DETAIL DRAWING FOR  
 PAVEMENT MARKINGS  
 LANE DROPS

- GENERAL NOTES:**
- USE THE GUIDANCE SHOWN ON THE ABOVE DETAILS IN CONJUNCTION WITH INTERSECTION GUIDANCE SHOWN ON ROADWAY STANDARD DRAWING 1205.04.
  - LANE LINES INDICATED AS "WIDE" SHALL BE AT LEAST TWICE THE WIDTH OF THE NORMAL LINE.

LEGEND	
W = WIDTH OF TRAVEL LANE	ONLY PAVEMENT MARKING SYMBOLS & CHARACTERS
◆ DIRECTION OF TRAFFIC FLOW	

SHEET 1 OF 3  
**1205D06**

SHEET 1 OF 3  
**1205D06**

**REVISED PAVEMENT MARKING  
ROADWAY STANDARD DRAWING**

08-MAR-2012 11:09 S:\S&DU\Standards Group\PMP\2012 Standard Drawings\Standard Dwgs 8-17-11\Revised\12050601L Revised 9-14-11\Sealed.dgn AT 1224745

TIP NO. I - 4733	SHEET NO. PMP - 1C
APPROVED: <i>RWF</i>	
DATE: 7/8/12	
SEAL	
	

STATE OF NORTH CAROLINA  
DEPT. OF TRANSPORTATION  
DIVISION OF HIGHWAYS  
RALEIGH, N.C.

**MULTI-LANE WIDTH "SCHOOL"**

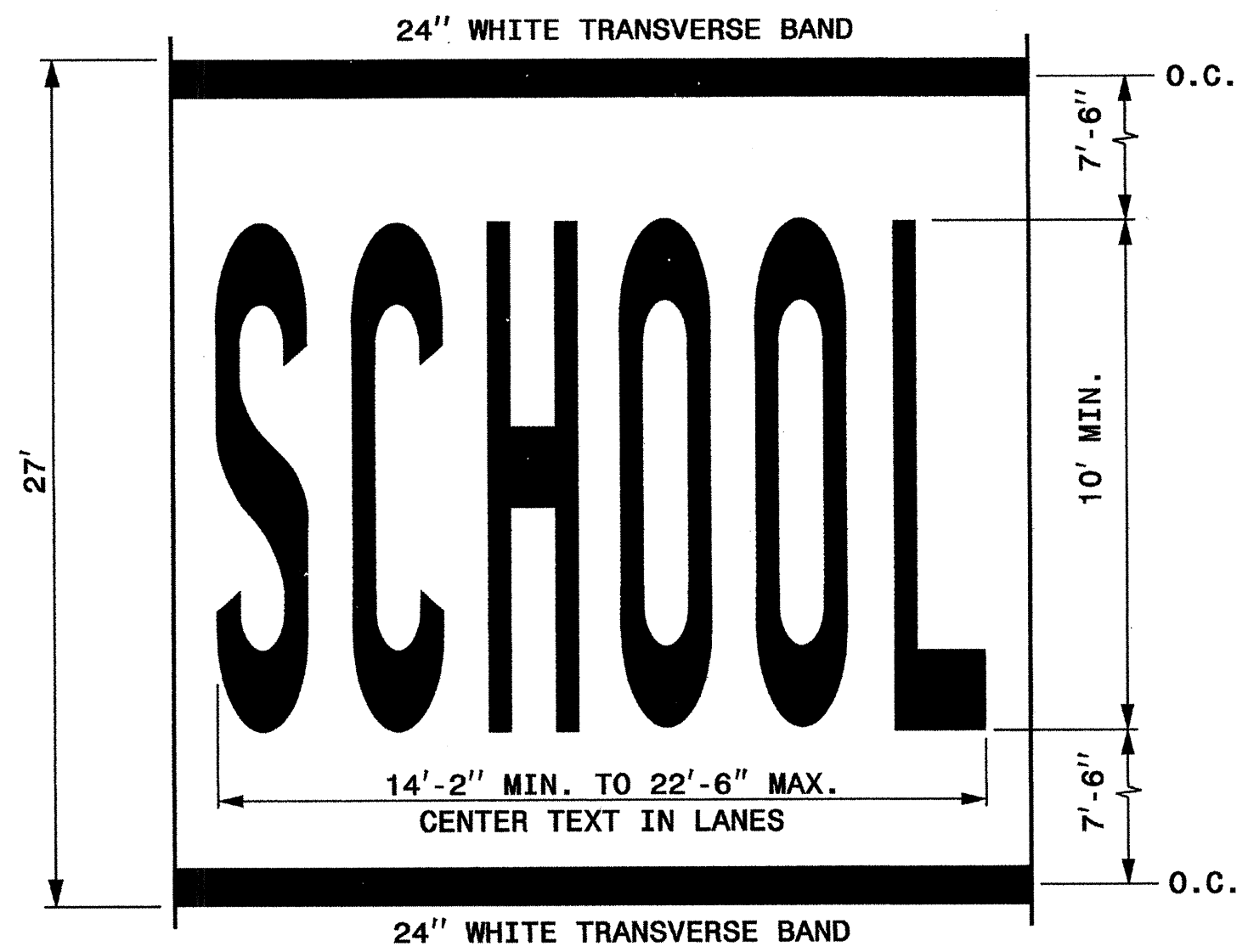

LETTER HEIGHT = 10' MIN.  
LETTER WIDTH = 20"  
SPACING = 10" MIN./30" MAX. (USE EQUAL SPACING BETWEEN LETTERS)  
NOTE: THE TWO-LANE PAVEMENT MARKING DIMENSIONS OF "SCHOOL" SHOWN IN PART 7 OF THE MUTCD MAY ALSO BE USED.

**SINGLE LANE WIDTH "SCHOOL"**

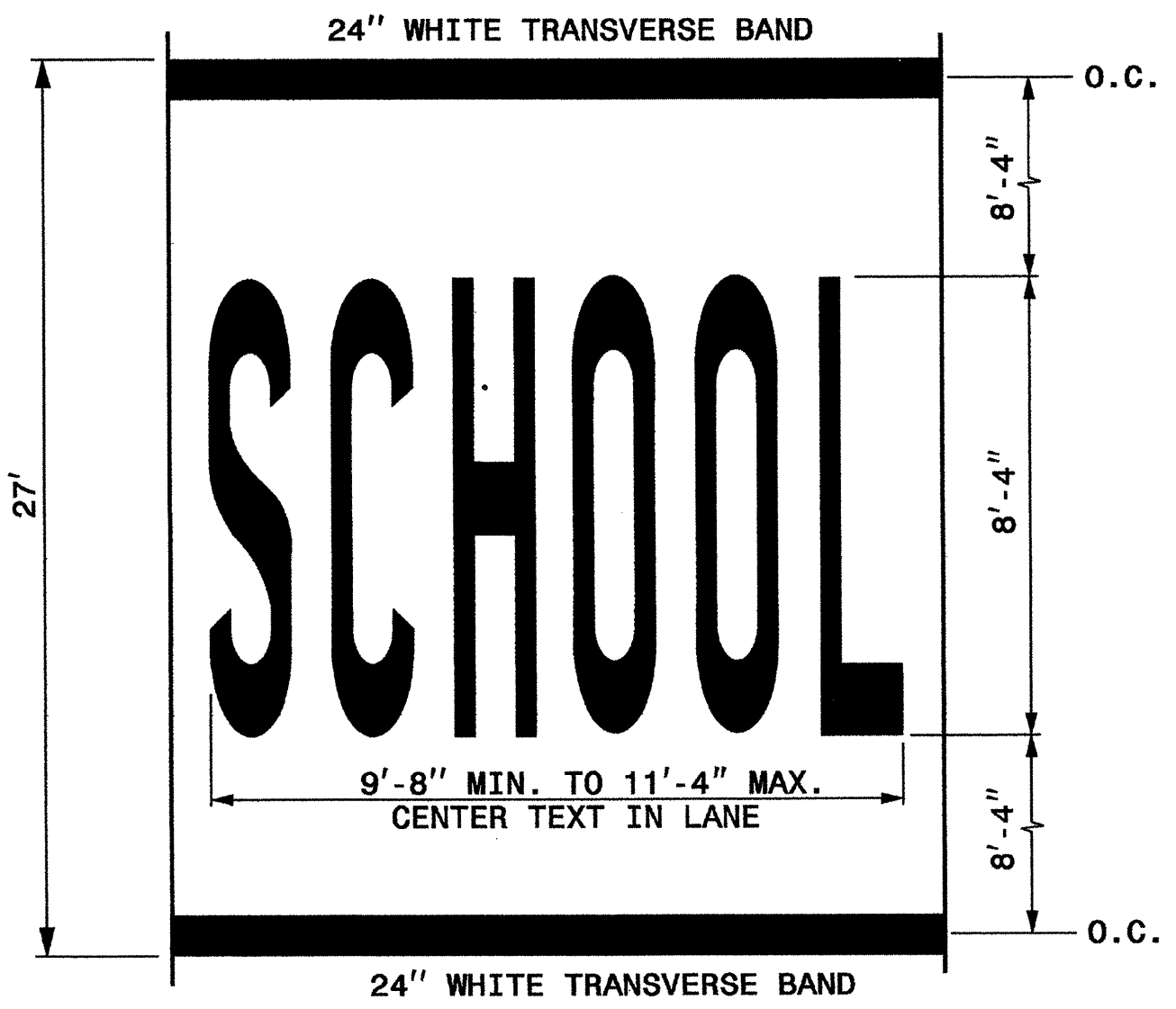

LETTER HEIGHT = 8'-4"  
LETTER WIDTH = 16"  
SPACING = 4" MIN./8" MAX. (USE EQUAL SPACING BETWEEN LETTERS)

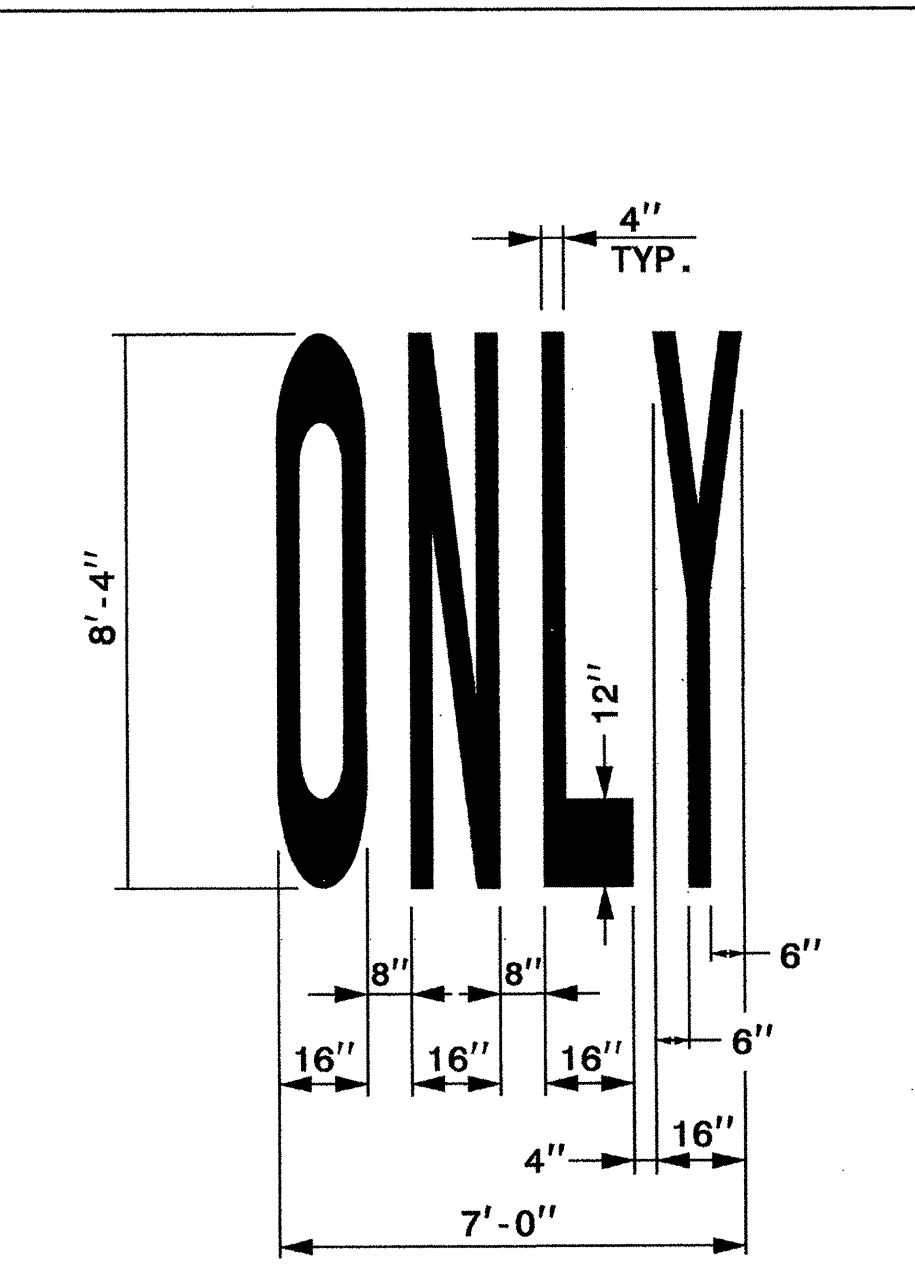

**RAILROAD RXR SYMBOL**

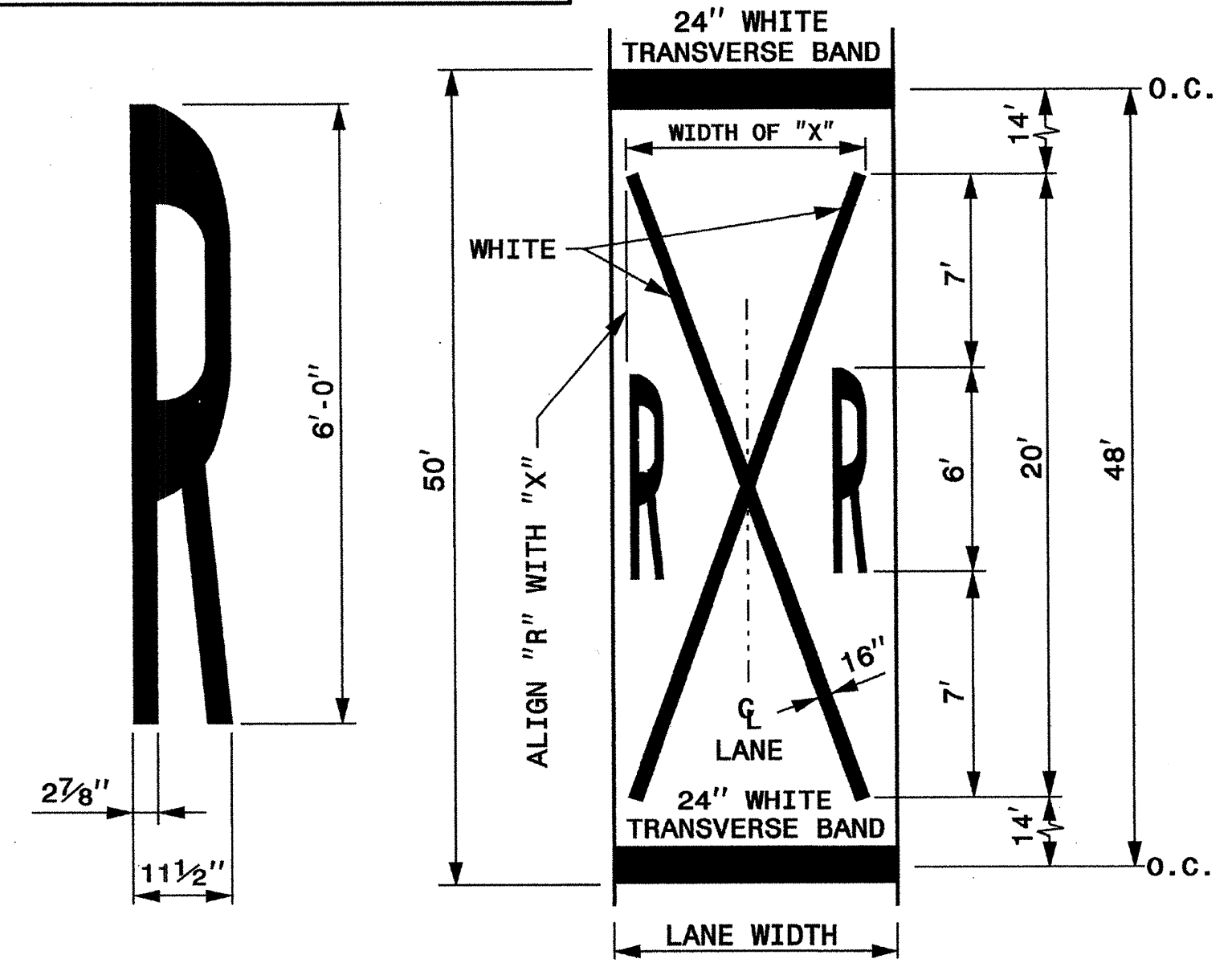

LANE WIDTH (FEET)	WIDTH OF "X" (FEET)
8' ≤ W ≤ 9'	7'
9' < W ≤ 12'	8'
W > 12'	10'

**GENERAL NOTES:**

- 1- THE SCHOOL PAVEMENT MARKING CONSISTS OF SIX (6) CHARACTERS. THE TWO (2) 24" TRANSVERSE BANDS WILL BE PAID FOR UNDER A SEPARATE PAY ITEM. REFER TO ROADWAY STANDARD DRAWING 1205.10 FOR ADDITIONAL PAVEMENT MARKING GUIDANCE.
- 2- PAVEMENT MARKING IN ADVANCE OF A HIGHWAY-RAIL CROSSING SHALL CONSIST OF TWO (2) CHARACTERS AND TWO (2) 16" LINES (FORMING AN X) WHICH ARE PAID FOR UNDER TWO SEPARATE PAY ITEMS. THE TWO (2) 24" TRANSVERSE BANDS WILL BE PAID FOR UNDER A SEPARATE PAY ITEM. REFER TO ROADWAY STANDARD DRAWING 1205.11 FOR ADDITIONAL PAVEMENT MARKING GUIDANCE.

SHEET 3 OF 8  
**1205D08**

STATE OF NORTH CAROLINA  
DEPT. OF TRANSPORTATION  
DIVISION OF HIGHWAYS  
RALEIGH, N.C.

ENGLISH DETAIL DRAWING FOR  
**PAVEMENT MARKINGS**  
SYMBOLS AND WORD MESSAGES

SHEET 3 OF 8  
**1205D08**

**REVISED PAVEMENT MARKING  
ROADWAY STANDARD DRAWING**

08-MAR-2012 12:18 St:\S&DU\Standard Drawings\Standard Drawings\8-17-11\Revised\1205D0803.Revised 9-14-11\_Scaled.dgn AT TE244745

TIP NO. I-4733	SHEET NO. PMP-2
APPROVED: <i>Betsy L. Watson</i>	
DATE: 5/8/13	
SEAL	
<small>Stantec Consulting Services Inc. 801 Jones Franklin Road Suite 300 Raleigh, NC 27606 Tel. (919) 851-8866 Fax. (919) 851-7024 www.stantec.com License No. F-0672</small>	

THERMOPLASTIC PAVEMENT MARKING LEGEND		
UA LEFT TURN ARROW	T6 WHITE EDGELINE (6")	TK 3 FT - 9 FT/SP WHITE MINISKIP (6")
UB RIGHT TURN ARROW	T7 YELLOW EDGELINE (6")	TL WHITE SOLID LANE LINE (6")
UC STRAIGHT ARROW	T8 2 FT - 6 FT/SP WHITE MINISKIP (4")	TN WHITE GORELINE (8")
UE COMBO STRAIGHT/RIGHT	T14 3 FT - 9 FT/SP WHITE MINISKIP (12")	TS WHITE GORELINE (12")
UI ONLY ALPHANUMERIC CHARACTERS	TA WHITE EDGELINE (4")	TT WHITE SOLID LANE LINE (12")
UI NORTH ALPHANUMERIC CHARACTERS	TB YELLOW EDGELINE (4")	TU WHITE DIAGONAL (12")
UI SOUTH ALPHANUMERIC CHARACTERS	TC 10 FT WHITE SKIP (4")	TV YELLOW DIAGONAL (12")
UP MERGE ARROW	TD 3 FT - 9 FT/SP WHITE MINISKIP (4")	
XX ROUTE SHIELD ON LIGHT PAVEMENT	TE WHITE SOLID LANE LINE (4")	
ZZ ROUTE SHIELD	TJ YELLOW DOUBLE CENTER (4")	
ZZ ROUTE SHIELD ON DARK PAVEMENT	TK 10 FT WHITE SKIP (6")	

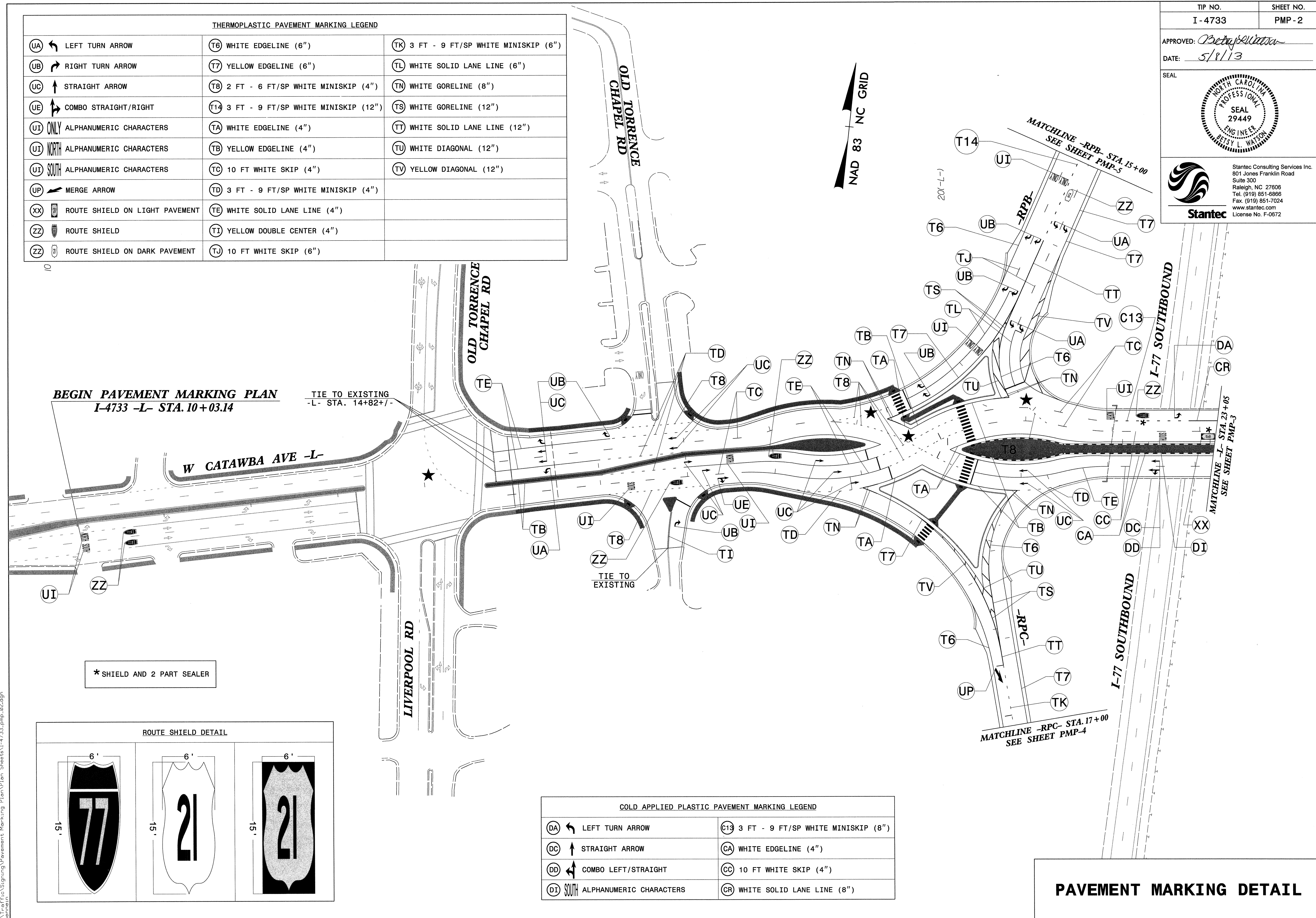

5/8/2013  
 U:\Projects\I-4733\Signing\Pavement Marking Plan\Plan Sheets\I-4733\_pmp-02.dgn  
 User: jmenzies

TIP NO. I - 4733	SHEET NO. PMP - 2A
APPROVED: <i>Betsy L. Watson</i>	
DATE: 4/22/13	
SEAL	
Stantec Consulting Services Inc. 801 Jones Franklin Road Suite 300 Raleigh, NC 27606 Tel. (919) 851-8866 Fax. (919) 851-7024 www.stantec.com License No. F-0672	

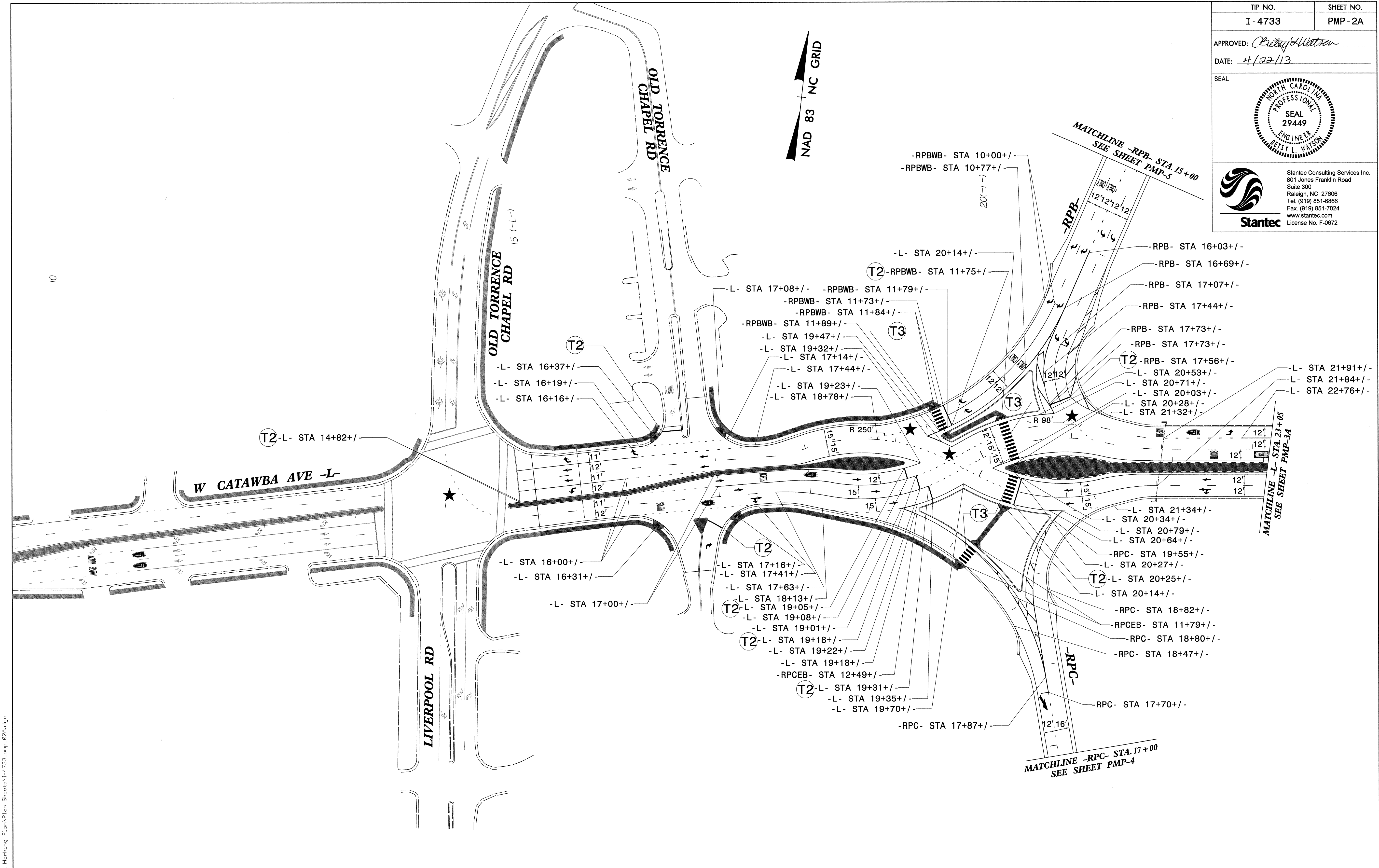

THERMOPLASTIC PAVEMENT MARKING LEGEND	
(T2)	WHITE STOPBAR (24")
(T3)	WHITE CROSSWALK LINE (24")

**PAVEMENT MARKING DETAIL**

U:\21203\c\Signing\Pavement Marking Plan\Plan Sheets\I-4733\_pmp\_02a.dgn  
 4/22/13  
 Betsy L. Watson

TIP NO. I-4733	SHEET NO. PMP-3
APPROVED: <i>Betsy L. Watson</i>	
DATE: 4/22/13	
SEAL	
Stantec Consulting Services Inc. 801 Jones Franklin Road Suite 300 Raleigh, NC 27606 Tel. (919) 851-6866 Fax. (919) 851-7024 www.stantec.com License No. F-0672	

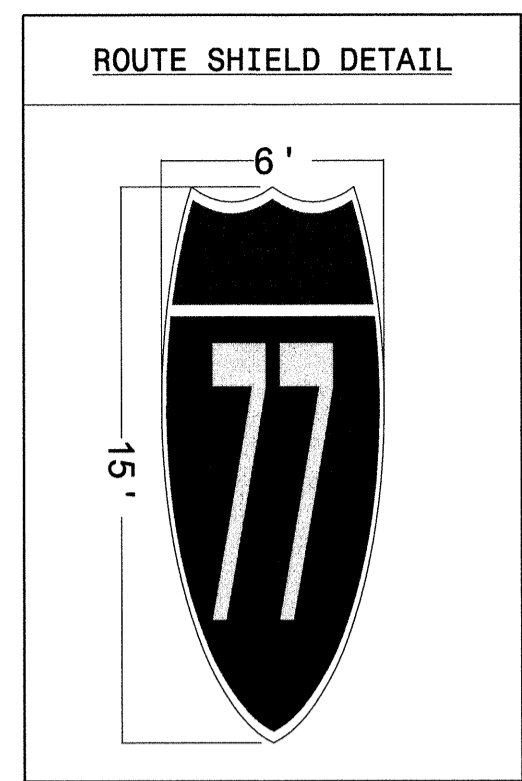

NAD 83 NC GRID

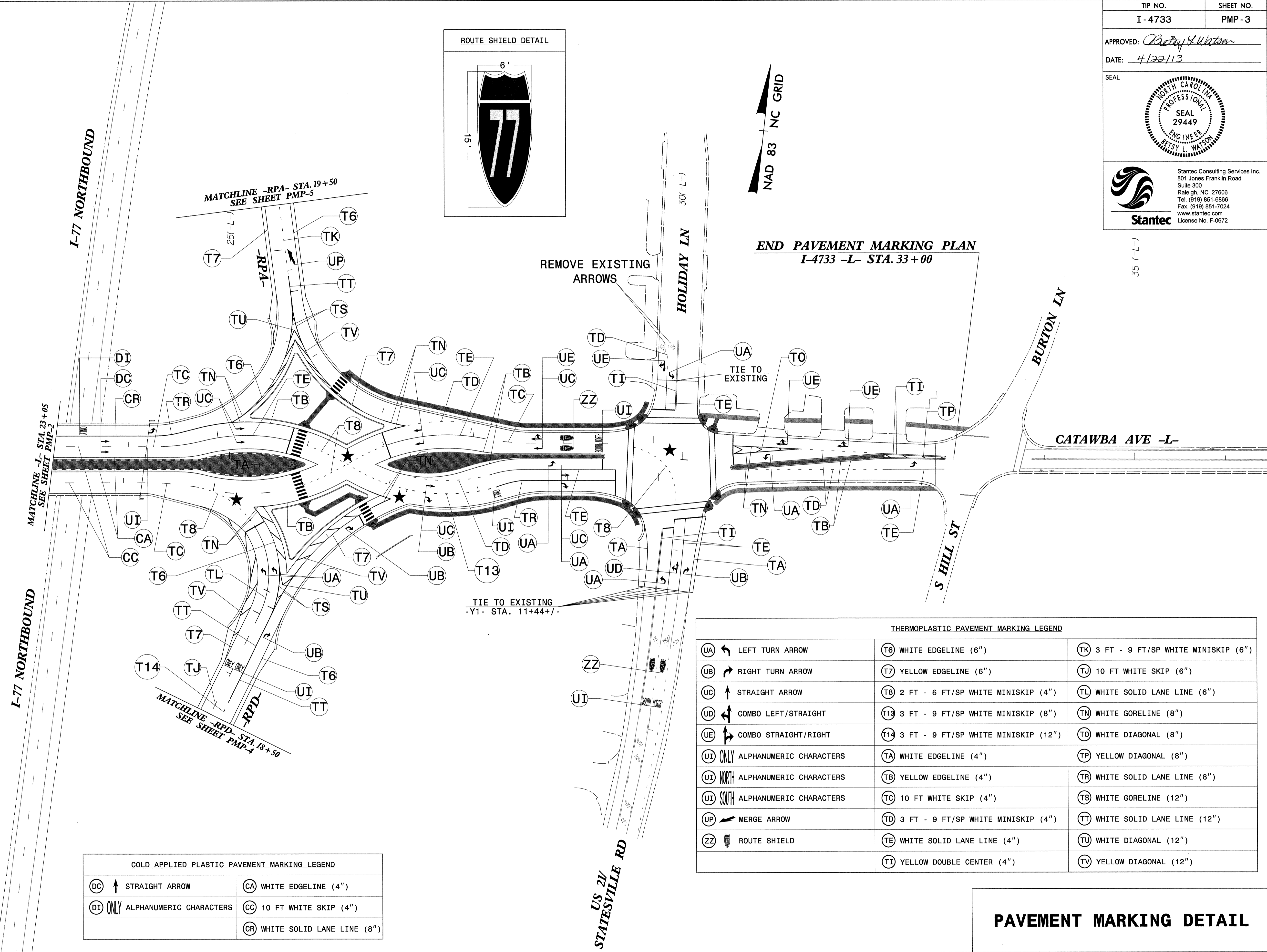

**END PAVEMENT MARKING PLAN**  
I-4733 -L- STA. 33+00

THERMOPLASTIC PAVEMENT MARKING LEGEND			
UA	LEFT TURN ARROW	TK	3 FT - 9 FT/SP WHITE MINISKIP (6")
UB	RIGHT TURN ARROW	TU	10 FT WHITE SKIP (6")
UC	STRAIGHT ARROW	TL	WHITE SOLID LANE LINE (6")
UD	COMBO LEFT/STRAIGHT	TN	WHITE GORELINE (8")
UE	COMBO STRAIGHT/RIGHT	TO	WHITE DIAGONAL (8")
UI ONLY	ALPHANUMERIC CHARACTERS	TP	YELLOW DIAGONAL (8")
UI NORTH	ALPHANUMERIC CHARACTERS	TR	WHITE SOLID LANE LINE (8")
UI SOUTH	ALPHANUMERIC CHARACTERS	TS	WHITE GORELINE (12")
UP	MERGE ARROW	TT	WHITE SOLID LANE LINE (12")
ZZ	ROUTE SHIELD	TU	WHITE DIAGONAL (12")
T6	WHITE EDGELINE (6")	TV	YELLOW DIAGONAL (12")
T7	YELLOW EDGELINE (6")		
T8	2 FT - 6 FT/SP WHITE MINISKIP (4")		
T13	3 FT - 9 FT/SP WHITE MINISKIP (8")		
T14	3 FT - 9 FT/SP WHITE MINISKIP (12")		
TA	WHITE EDGELINE (4")		
TB	YELLOW EDGELINE (4")		
TC	10 FT WHITE SKIP (4")		
TD	3 FT - 9 FT/SP WHITE MINISKIP (4")		
TE	WHITE SOLID LANE LINE (4")		
TI	YELLOW DOUBLE CENTER (4")		

COLD APPLIED PLASTIC PAVEMENT MARKING LEGEND	
DC	STRAIGHT ARROW
DI ONLY	ALPHANUMERIC CHARACTERS
CA	WHITE EDGELINE (4")
CC	10 FT WHITE SKIP (4")
CR	WHITE SOLID LANE LINE (8")

**PAVEMENT MARKING DETAIL**

4/22/2013 9:58:10 AM Signing Pavement Marking Plan\Plan\_Sheets\I-4733-pmp-03.dgn





APPROVED: *Betsy L. Watson*  
 DATE: 4/22/13

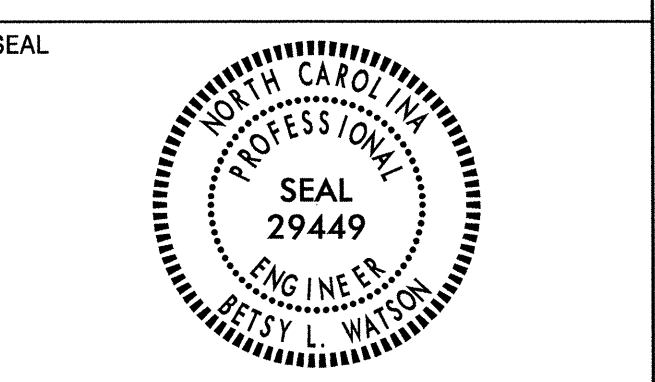

**Stantec**  
 Stantec Consulting Services Inc.  
 801 Jones Franklin Road  
 Suite 300  
 Raleigh, NC 27606  
 Tel. (919) 851-6866  
 Fax. (919) 851-7024  
 www.stantec.com  
 License No. F-0672

NAD 83 NC GRID

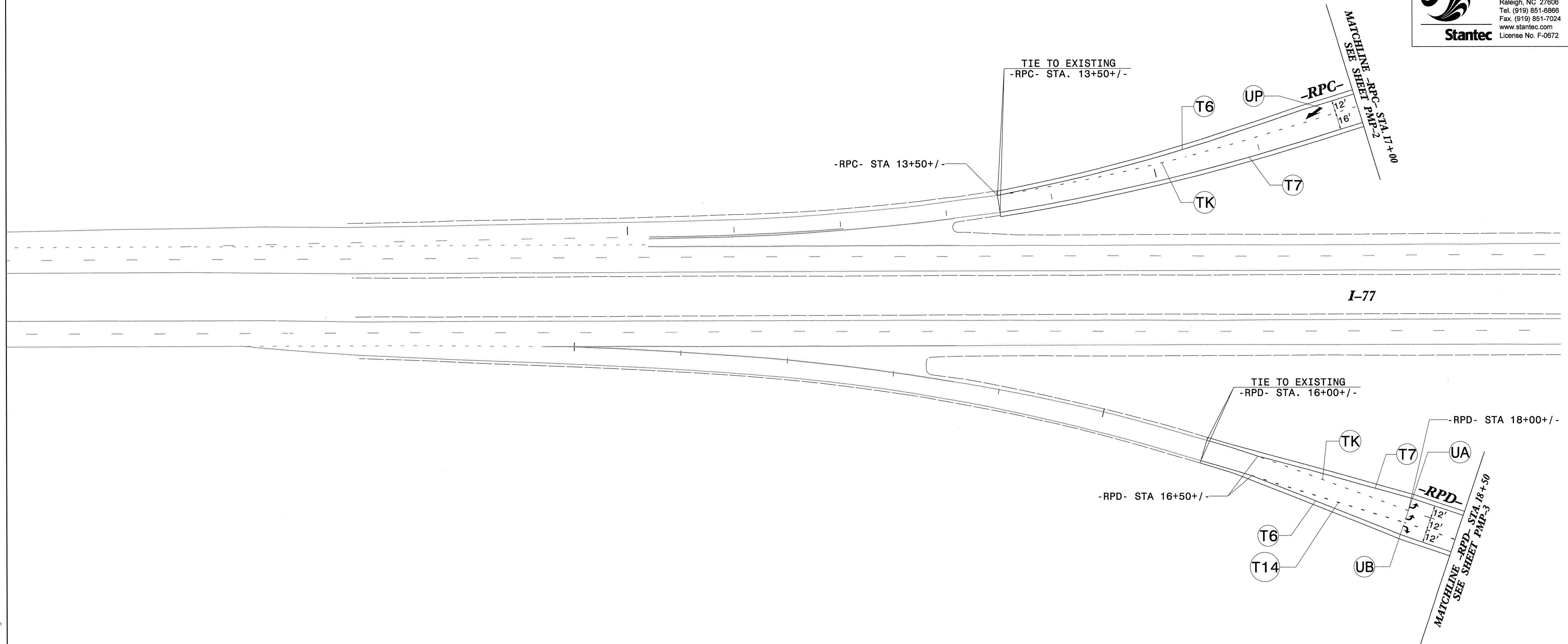

THERMOPLASTIC PAVEMENT MARKING LEGEND			
(UA)	← LEFT TURN ARROW	(T6)	WHITE EDGELINE (6")
(UB)	↪ RIGHT TURN ARROW	(T7)	YELLOW EDGELINE (6")
(UP)	↙ MERGE ARROW	(T14)	3 FT - 9 FT/SP WHITE MINISKIP (12")
		(TK)	3 FT - 9 FT/SP WHITE MINISKIP (6")

**PAVEMENT MARKING DETAIL**

4/22/2013 10:58am Signum Pavement Marking Plan\Plan Sheets\I-4733\_pmp\_04.dgn

TIP NO. I-4733	SHEET NO. PMP-5
APPROVED: <i>Betsy L. Watson</i>	
DATE: 4/22/13	
SEAL	
<small>Stantec Consulting Services Inc. 801 Jones Franklin Road Suite 300 Raleigh, NC 27606 Tel. (919) 851-6868 Fax. (919) 851-7024 www.stantec.com License No. F-0672</small>	

NAD 83 NC GRID

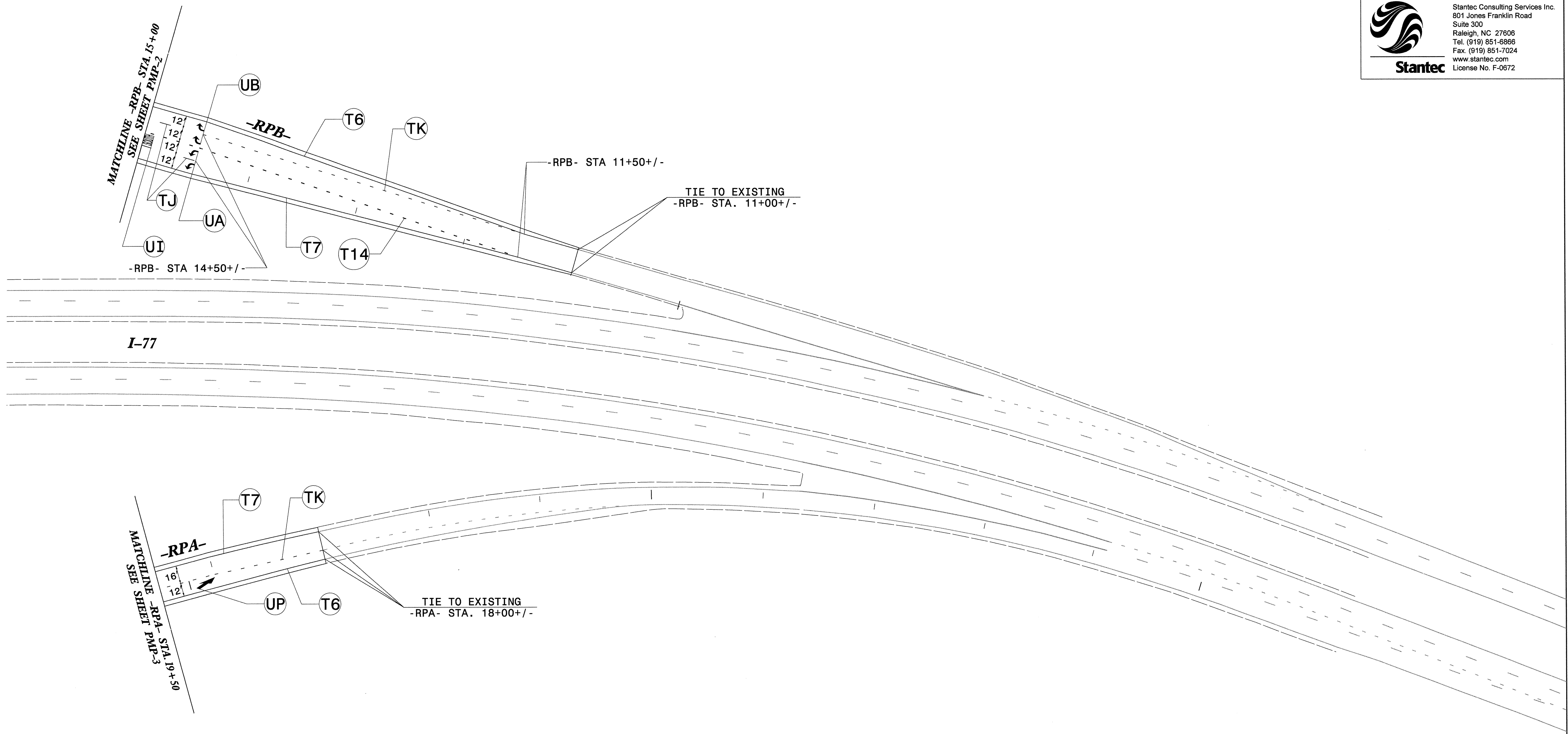

THERMOPLASTIC PAVEMENT MARKING LEGEND	
(UA) LEFT TURN ARROW	(T6) WHITE EDGELINE (6")
(UB) RIGHT TURN ARROW	(T7) YELLOW EDGELINE (6")
(UI) SOUTH ALPHANUMERIC CHARACTERS	(T14) 3 FT - 9 FT/SP WHITE MINISKIP (12")
(UP) MERGE ARROW	(TU) 10 FT WHITE SKIP (6")
	(TK) 3 FT - 9 FT/SP WHITE MINISKIP (6")

**PAVEMENT MARKING DETAIL**

4/22/13  
 User: bfw  
 Location: Signing/Pavement Marking/Plan/Plan Sheets/I-4733.pmp.05.dgn  
 Filename: