

T.I.P.: R-2707AA

CONTRACT:

**STATE OF NORTH CAROLINA
DEPARTMENT OF TRANSPORTATION**

**SIGNING PLAN
CLEVELAND COUNTY**

**LOCATION: US-74 (SHELBY BYPASS) FROM WEST OF SR 1162
(PEACHTREE RD) TO EAST OF SR 1318 (KIMBRELL RD)**

TIP NO. R-2707AA	SHEET NO. SIGN-1
APPROVED:	
DATE: 10-30-2012	
SEAL	

ROADWAY STANDARD DRAWING

THE FOLLOWING ROADWAY STANDARDS AS APPEAR IN "ROADWAY STANDARD DRAWINGS" - PROJECT SERVICES UNIT - N.C. DEPARTMENT OF TRANSPORTATION - RALEIGH, N.C., DATED JANUARY 2012 ARE APPLICABLE TO THIS PROJECT AND BY REFERENCE HEREBY ARE CONSIDERED A PART OF THESE PLANS:

STD. NO.	TITLE
901.10	TYPE 'A' SIGNS
901.20	TYPE 'B' SIGNS
901.50	ARROWS AND SHIELDS
901.70	SIGN STRINGERS AND SUPPORT SPACING
901.80	SIGN MOUNTING DETAILS - FOR TYPE A AND TYPE B SIGNS
903.10	GROUND MOUNTED SIGN SUPPORTS (EXCEPT 2 OF 3 WHICH IS REPLACED WITH SIGN-2A IN PLANS)
904.10	ORIENTATION OF GROUND MOUNTED SIGNS
904.20	SECONDARY SIGN MOUNTING
904.30	SUPPLEMENTAL SIGN MOUNTING
904.40	MILEPOST AND PLACEMENT
904.50	MOUNTING OF TYPE 'D', 'E' AND 'F' SIGNS ON 'U' CHANNEL POSTS
1264.01	OBJECT MARKERS
1264.02	PLACEMENT OF OBJECT MARKERS

GENERAL NOTES

- SIGNS FURNISHED BY STATE
- ALL EXISTING SIGNS/SIGN SYSTEMS WITHIN THE PROJECT LIMITS SHALL BE REMOVED AND DISPOSED OF UNLESS OTHERWISE NOTED ON PLANS. THE SIGNS TO BE DISPOSED ARE NOT SHOWN IN PLANS; HOWEVER THE PAY ITEM/QUANTITY IS INCLUDED IN THE CONTRACT.
- ALL TYPE 'D' SIGNS SHALL BE MOUNTED ON TWO U-CHANNEL POSTS UNLESS OTHERWISE INDICATED ON THE PLANS.
- IF REMOVAL OR RELOCATION OF SIGNS ON PRIVATE STREET (NON-STATE MAINTAINED) IS REQUIRED DUE TO CONSTRUCTION, THE CONTRACTOR SHALL INFORM THE ENGINEER. THE WORK WILL BE COMPLETED BY OTHERS.
- SIGNING PLANS DO NOT INCLUDE TEMPORARY CONSTRUCTION SIGNING, SEE TRAFFIC CONTROL PLANS. SEE PAVEMENT MARKING PLAN FOR PAVEMENT MARKING DESIGN.
- WHEN NOT STATIONED OR DIMENSIONED ON PLANS, ALL 'E' AND 'F' SIGNS SHALL BE FIELD LOCATED BY THE ENGINEER.
- WHEN EXISTING SIGNS ARE REMOVED AND INSTALLED ON NEW SUPPORTS, THE RE-ERECTION SHALL IMMEDIATELY FOLLOW THE REMOVAL.
- THE BACKGROUND FOR TYPE E, F & MILEMARKER SIGNS SHALL BE GRADE C REFLECTIVE SHEETING.
- DO NOT BEGIN FABRICATION FOR TYPES A & B SIGNS MOUNTED ON OVERHEAD STRUCTURES OR STEEL SUPPORTS UNTIL "S" DIMENSIONS HAVE BEEN FIELD VERIFIED.
- SEE ROADWAY PLANS FOR GUARD/GUIDE RAIL DETAILS.

SUMMARY OF QUANTITIES

ITEM NO.	ITEM DESCRIPTION	QUANTITY	UNIT
DESC. NO.	SECT. NO.		
4048000000	902	REINFORCED CONCRETE SIGN FOUNDATION	6 C.Y.
4054000000	902	PLAIN CONCRETE SIGN FOUNDATION	1 C.Y.
4057000000	SP	OVERHEAD FOOTING	84 C.Y.
4060000000	903	SUPPORTS, BREAKAWAY STEEL BEAM	5902 LB.
4072000000	903	SUPPORTS, 3 LB STEEL U-CHANNEL	1852 L.F.
4078000000	903	SUPPORTS, 2 LB STEEL U-CHANNEL	4 E.A.
4082100000	SP	SUPPORTS, OVERHEAD SIGN STRUCTURE AT STATION "24+67 -L-"	1 L.S.
4082100000	SP	SUPPORTS, OVERHEAD SIGN STRUCTURE AT STATION "43+20 -L-"	1 L.S.
4082100000	SP	SUPPORTS, OVERHEAD SIGN STRUCTURE AT STATION "44+50 -L-"	1 L.S.
4082100000	SP	SUPPORTS, OVERHEAD SIGN STRUCTURE AT STATION "74+50 -L-"	1 L.S.
4082100000	SP	SUPPORTS, OVERHEAD SIGN STRUCTURE AT STATION "78+00 -L-"	1 L.S.
4082100000	SP	SUPPORTS, OVERHEAD SIGN STRUCTURE AT STATION "62+00 -L-"	1 L.S.
4082100000	SP	SUPPORTS, OVERHEAD SIGN STRUCTURE AT STATION "40+00 -RAMPB-"	1 L.S.
4096000000	904	SIGN ERECTION, TYPE D	10 EA.
4102000000	904	SIGN ERECTION, TYPE E	93 EA.
4108000000	904	SIGN ERECTION, TYPE F	10 EA.
4110000000	904	SIGN ERECTION, TYPE A (GROUND MOUNTED)	6 EA.
4110000000	904	SIGN ERECTION, TYPE B (GROUND MOUNTED)	5 EA.
4114000000	904	SIGN ERECTION, MILEMARKERS	4 EA.
4155000000	907	DISPOSAL OF SIGN SYSTEM, U-CHANNEL	60 EA.

PAY ITEM NOTES

- 1 SIGN ERECTION, TYPE A (GROUND MOUNTED)
- 2 SIGN ERECTION, TYPE B (GROUND MOUNTED)
- 3 SIGN ERECTION, TYPE D, E, AND F
- 4 SIGN ERECTION, MILEMARKERS

INDEX

SHEET NO.	DESCRIPTION
SIGN-1	TITLE SHEET
SIGN-2-2A	SUPPORT INFORMATION AND GROUND MOUNT SHEETS
SIGN-3-3F	OVERHEAD STRUCTURE LINE DRAWINGS
SIGN-4-4G	SIGN DESIGNS, TYPE E & F SIGNS AND MILEMARKERS
SIGN-5-13	SIGN DETAIL SHEETS

CONTACTS: N.C.D.O.T. SIGNING AND DELINEATION UNIT

KELVIN JORDAN _____ SIGNING & DELINEATION REGIONAL ENGINEER
BOBBY NAVARRETE _____ SIGNING & DELINEATION PROJECT DESIGN ENGINEER

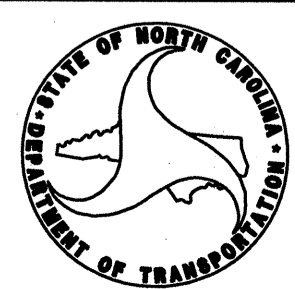

PLAN PREPARED BY :

HNTB HNTB NORTH CAROLINA, P.C.
343 E. Six Forks Road, Suite 200
Raleigh, North Carolina 27609
NC License No: C-1954

C.A. JOHNSON, III, PE SIGNING PROJECT ENGINEER
A.D. KLINKSIEK, E.I. SIGNING DESIGN ENGINEER
T.R. TERRELL SIGNING DESIGN TECHNICIAN

TYPE "A" AND "B" GROUND MOUNTED SIGNS

SIGN NO.	SIGN TYPE	SIZE (in.)			ROADWAY STATION	NO. OF SUP.	BEAM SECTION	SUPPORT TYPE BA or S	ATTACH METHOD	MOUNTING METHOD	HORIZ. CLR. (ft.)	SNS HT H	MTG HT C	EMBED-MENT	TOTAL LENGTH			TOTAL LENGTH			FOOTING DIAMETER (ft.)	FOOTING DEPTH (ft.)	SUPPORT WEIGHTS (lbs.)	SUPPORT WEIGHTS (lbs.)	REINF. FTGS. (c.y.)	PLAIN FTGS. (c.y.)	FIELD VERIFIED (mm/dd/yy)												
		w	x	h											S	L	TOTAL LENGTH	S	L	TOTAL LENGTH																			
101A	B	132	X	30	US-74 EB	3	W8x21	BA	1-R	N/A	25.00	8.50	14.40	6	-0.60	22.30	28.30	-4.00	18.90	24.90	-7.40	15.50	21.50	2	6.5	1847.13	0.00	2.27	0.00										
*101B	A	228	X	102																																			
102A	B	132	X	30	US-74 EB	3	W6x16	BA	1-R	N/A	30.00	8.50	8.70	5.5	-1.70	15.50	21.00	-1.70	15.50	21.00	-1.70	15.50	21.00	1.5	6	1206.57	0.00	1.18	0.00										
102B	A	228	X	102																																			
103	B	108	X	36	US-74 WB	2	S3x5.7	BA	N/A	N/A	30.00	3.00	7.50	3.5	2.75	13.25	16.75	0.00	0.00	0.00	-0.50	10.00	13.50	1	4	207.96	0.00	0.00	0.23										
104	A	174	X	90	8+90 -L- EB	2	W8x18	BA	N/A	N/A	30.00	7.50	7.00	5	5.02	19.52	24.52	0.00	0.00	0.00	6.64	21.14	26.14	2	5.5	1074.00	0.00	1.28	0.00										
105	A	174	X	90	52+50 -L-	2	W6x16	BA	N/A	N/A	30.00	7.50	7.27	5	3.07	17.84	22.84	0.00	0.00	0.00	-0.27	14.50	19.50	1.5	5.5	809.82	0.00	0.72	0.00										
106	B	120	X	36	13+00 -Y6-	2	S3x5.7	BA	N/A	N/A	30.00	3.00	7.00	3.5	3.13	13.13	16.63	0.00	0.00	0.00	1.53	11.53	15.03	1	4	215.99	0.00	0.00	0.23										
201	A	96	X	60	28+00 +/- -L-	2	S3x5.7	BA	N/A	N/A	△	5.00	7.00	3.5	0.10	12.10	15.60	0.00	0.00	0.00	0.10	12.10	15.60	1	4	213.37	0.00	0.00	0.23										
202A	A	96	X	60	39+75 +/- -L-	2	S4x7.7	BA	N/A	2	△	7.00	7.00	4.5	0.10	14.10	18.60	0.00	0.00	0.00	0.10	14.10	18.60	1	5	327.05	0.00	0.00	0.29										
202B	B	96	X	24																																			
																						TOTAL	5901.90	TOTAL	0.00	TOTAL	5.45	TOTAL	0.99										
																						USE:	5902	0	6	1													

*Support spacing is 7.60'.

NOTES

DIMENSION "S" REPRESENTS AN INCREASE (+), OR A DECREASE (-) IN POLE LENGTH, RELATIVE TO THE ELEVATION OF THE EDGE OF PAVEMENT.

FIELD VERIFICATIONS SHALL BE REQUIRED FOR ALL SUPPORTS, SEE (*) ARTICLE 903-3. FABRICATORS SHALL BE AISC CERTIFIED IN CATEGORY 1, SEE (*) ARTICLE 1072-1. (*) = N.C.D.O.T. STANDARD SPECIFICATIONS FOR ROADS AND STRUCTURES

PLAN LOCATIONS FOR EXISTING UTILITIES ARE BASED ON THE BEST AVAILABLE INFORMATION AND, THEREFORE MAY NOT BE PRECISELY ACCURATE. THEREFORE, IT IS INCUMBENT UPON THE CONTRACTOR TO DETERMINE THE EXACT LOCATION OF UTILITIES BEFORE BEGINNING WORK IN A LOCATION.

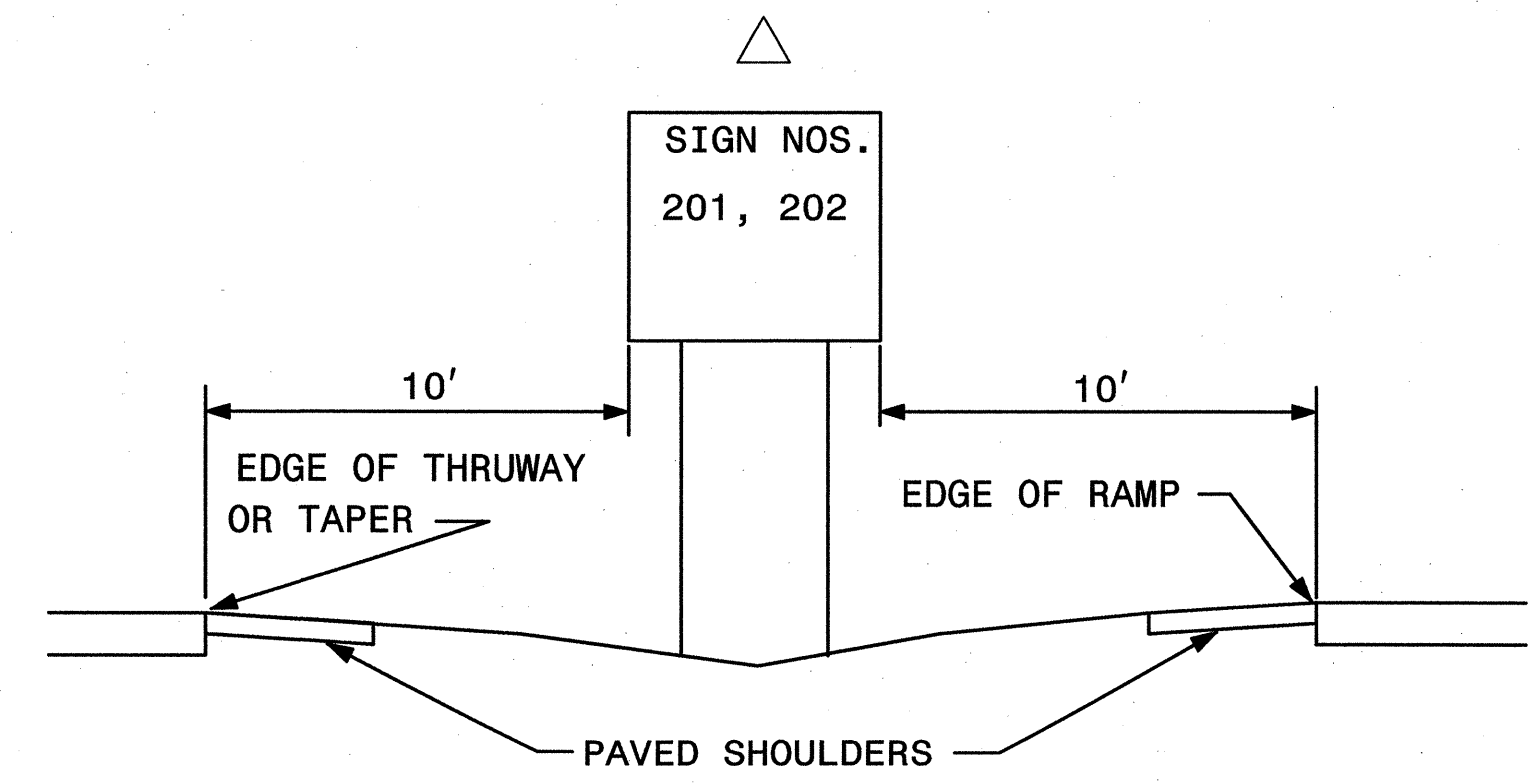
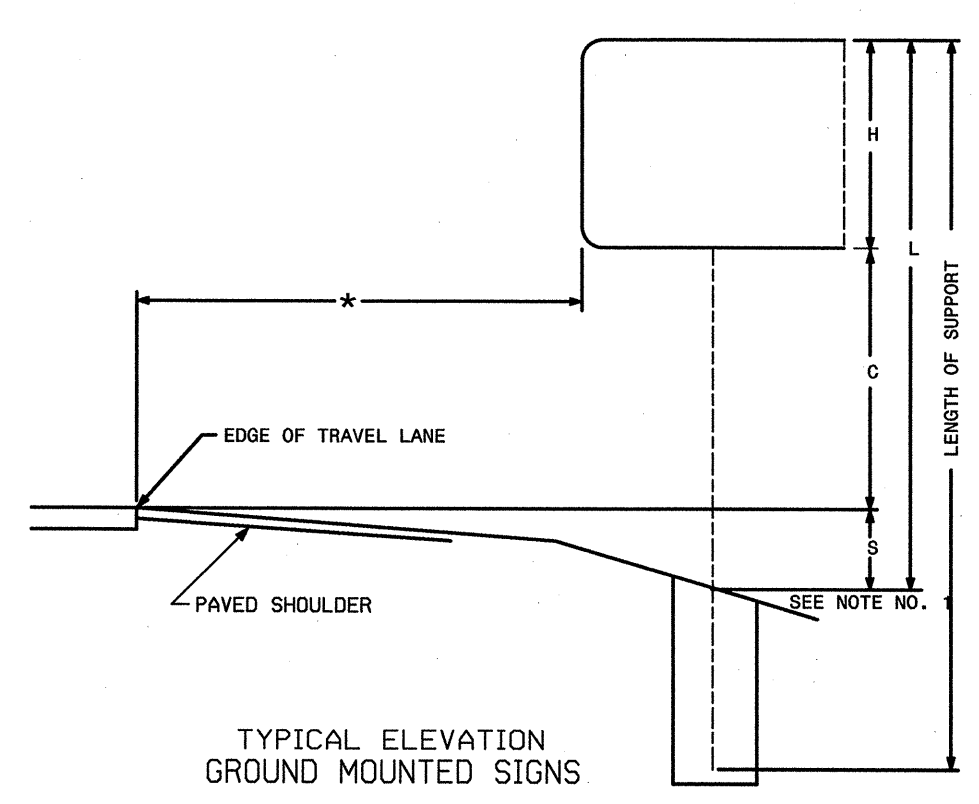

TIP NO. R-2707AA	SHEET NO. SIGN-2A
APPROVED: <i>RWF</i>	
DATE: 3/8/12	
SEAL	
	

STATE OF NORTH CAROLINA
 DEPT. OF TRANSPORTATION
 DIVISION OF HIGHWAYS
 RALEIGH, N.C.

ENGLISH DETAIL DRAWING FOR
GROUND MOUNTED SIGN SUPPORTS

SHEET 2 OF 3
903D10

BEAM SHAPE	SLIP BASE PLATE DATA								KEEPER PLATE DATA								HINGE CONNECTION DATA								BREAK AWAY SUPPORT WEIGHT CONSTANT LBS.	
	BOLT SIZE	A ₁	B ₁	C ₁	D ₁	E ₁	T ₁	R ₁	A ₂	B ₂	C ₂	D ₂	E ₂	R ₂	T ₂	BOLT SIZE	F	G	H	I	J	K	L	R ₃		T ₃
S3X5.7	1/2"DIA. X 3"	7"	4"	1"	3/4"	2 1/2"	1"	3/32"	7"	4"	1"	3/4"	2 1/2"	3/32"	28 GAUGE	1/2"DIA. X 1 1/4"	2 1/4"	3 1/2"	4"	1 1/2"	1"	1 1/2"	2"	3/32"	3/8"	18
S4X7.7	1/2"DIA. X 3"	8"	4"	1"	3/4"	2 1/2"	1"	3/32"	8"	4"	1"	3/4"	2 1/2"	3/32"	28 GAUGE	1/2"DIA. X 1 1/4"	2 5/8"	3 1/2"	4"	1 1/2"	1"	1 1/2"	2"	3/32"	3/8"	20
W6X9	1/2"DIA. X 3"	10"	5"	1"	3/4"	3 1/2"	1"	3/32"	10"	5"	1"	3/4"	3 1/2"	3/32"	28 GAUGE	1/2"DIA. X 1 1/4"	4"	3 1/2"	4"	3/4"	1"	1 1/2"	2"	3/32"	3/8"	32
W6X12	5/8"DIA. X 3 3/4"	11"	5"	1 1/4"	7/8"	3 1/4"	1 1/4"	1 1/32"	11"	5"	1 1/4"	7/8"	3 1/4"	1 1/32"	28 GAUGE	5/8"DIA. X 2 1/4"	4"	4"	4 1/2"	3/4"	1 1/8"	5/8"	2 1/4"	1 1/32"	3/8"	39
W6X16	5/8"DIA. X 3 3/4"	12"	6"	1 1/4"	7/8"	4 1/4"	1 1/2"	1 1/32"	12"	6"	1 1/4"	7/8"	4 1/4"	1 1/32"	28 GAUGE	5/8"DIA. X 2 1/2"	4"	4"	4 1/2"	3/4"	1 1/8"	5/8"	2 1/4"	1 1/32"	1 1/2"	47
W8X18	5/8"DIA. X 4 1/4"	13 1/2"	6 1/2"	1 1/4"	7/8"	4 3/4"	1 1/2"	1 1/32"	13 1/2"	6 1/2"	1 1/4"	7/8"	4 3/4"	1 1/32"	28 GAUGE	5/8"DIA. X 2 1/2"	5 1/4"	4"	4 1/2"	1"	1 1/8"	5/8"	2 1/4"	1 1/32"	1 1/2"	70
W8X21	3/4"DIA. X 4 1/4"	14"	7"	1 1/2"	1"	5"	1 1/2"	1 3/32"	14"	7"	1 1/2"	1"	5"	1 3/32"	28 GAUGE	3/4"DIA. X 2 3/4"	5 1/4"	6"	7"	1"	1 3/4"	3/4"	3 1/2"	1 3/32"	1 1/2"	73
W10X22	3/4"DIA. X 4 1/4"	16"	8"	1 1/2"	1"	6"	1 1/2"	1 3/32"	16"	8"	1 1/2"	1"	6"	1 3/32"	28 GAUGE	3/4"DIA. X 2 3/4"	5 3/4"	6"	7"	1"	1 3/4"	3/4"	3 1/2"	1 3/32"	1 1/2"	119
W10X26	3/4"DIA. X 4 3/4"	16 1/2"	8"	1 1/2"	1"	6"	1 3/4"	1 3/32"	16 1/2"	8"	1 1/2"	1"	6"	1 3/32"	28 GAUGE	3/4"DIA. X 2 3/4"	5 3/4"	6"	7"	1"	1 3/4"	3/4"	3 1/2"	1 3/32"	5/8"	140
W12X26	3/4"DIA. X 4 3/4"	18 1/2"	9"	1 1/2"	1"	7"	1 3/4"	1 3/32"	18 1/2"	9"	1 1/2"	1"	7"	1 3/32"	28 GAUGE	3/4"DIA. X 2 3/4"	6 1/2"	6"	7"	1"	1 3/4"	3/4"	3 1/2"	1 3/32"	5/8"	176
W14X30	1"DIA. X 5"	22"	9"	2"	1 1/2"	6"	2"	1 7/32"	22"	9"	2"	1 1/2"	6"	1 7/32"	28 GAUGE	1"DIA. X 3"	6 3/4"	7"	8"	1 1/4"	2"	1"	4"	1 7/32"	5/8"	205
W16X31	1"DIA. X 5"	24"	9"	2"	1 1/2"	6"	2"	1 7/32"	24"	9"	2"	1 1/2"	6"	1 7/32"	28 GAUGE	1"DIA. X 3 1/4"	5 1/2"	7"	8"	1 1/4"	2"	1"	4"	1 7/32"	3/4"	223
W18X35	1"DIA. X 5"	25"	9"	2"	1 1/2"	6"	2"	1 7/32"	25"	9"	2"	1 1/2"	6"	1 7/32"	28 GAUGE	1"DIA. X 3 1/4"	6"	7"	8"	1 1/4"	2"	1"	4"	1 7/32"	3/4"	243
W18X40	1"DIA. X 5 1/2"	26"	9"	2"	1 1/2"	6"	2 1/4"	1 7/32"	26"	9"	2"	1 1/2"	6"	1 7/32"	28 GAUGE	1"DIA. X 3 3/4"	6"	7"	8"	1 1/4"	2"	1"	4"	1 7/32"	7/8"	278
W21X44	1"DIA. X 5 1/2"	29"	9"	2"	1 1/2"	6"	2 1/2"	1 7/32"	29"	9"	2"	1 1/2"	6"	1 7/32"	28 GAUGE	1"DIA. X 3 3/4"	6 1/2"	7"	8"	1 1/4"	2"	1"	4"	1 7/32"	7/8"	310

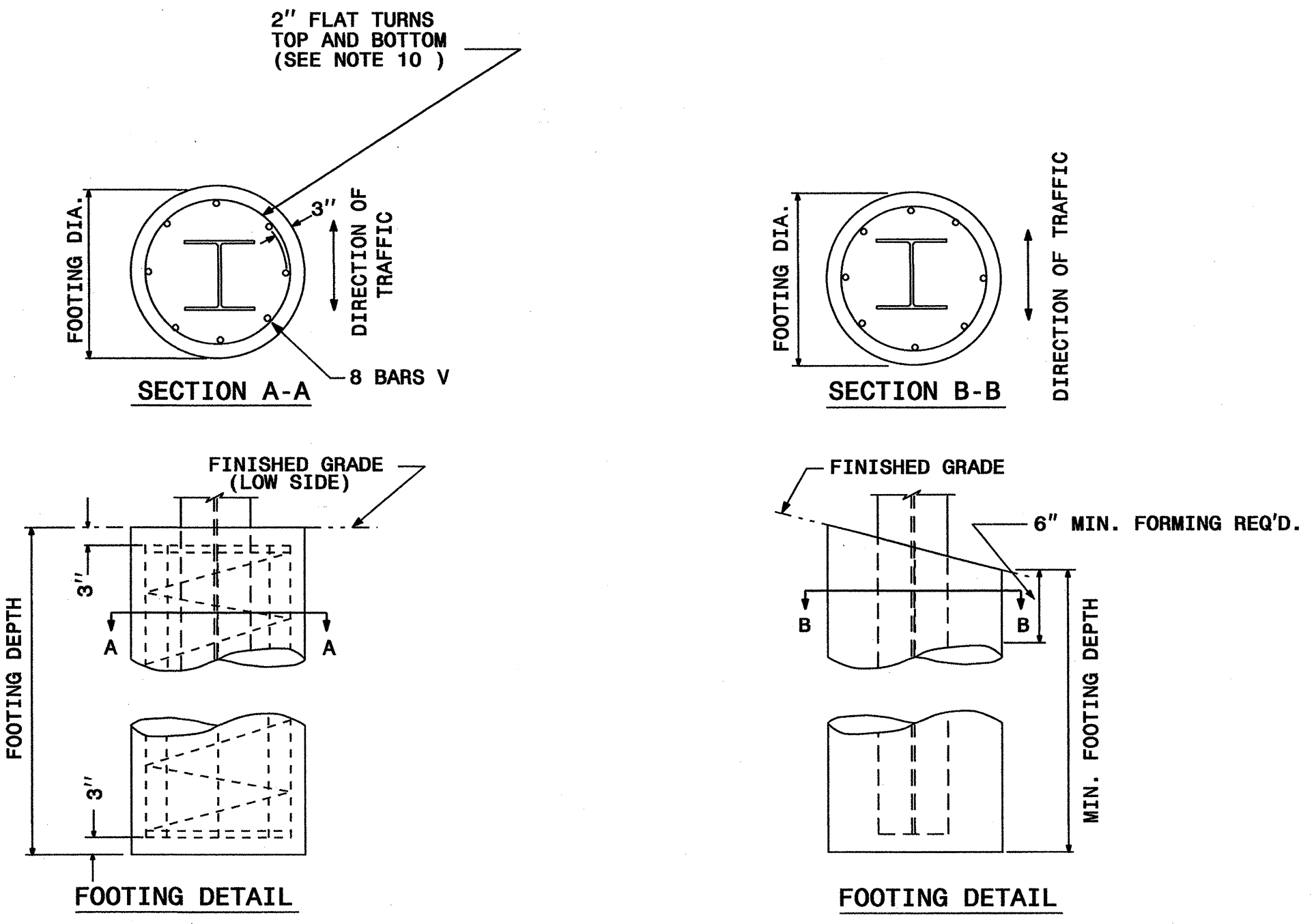

FOUNDATION DATA *		
FOOTING DIAMETER	REINFORCEMENT	SPIRAL BAR
1' 6"	8 # 6 BARS	#3 BAR, 6" PITCH
2'	8 # 7 BARS	#3 BAR, 6" PITCH
2' 6"	8 # 9 BARS	#3 BAR, 6" PITCH
3'	8 # 11 BARS	#3 BAR, 6" PITCH
3' 6"	8 # 12 BARS	#3 BAR, 6" PITCH
4'	8 # 14 BARS	#3 BAR, 6" PITCH

* FOUNDATION DIMENSIONS ARE SHOWN IN PLANS

STATE OF NORTH CAROLINA
 DEPT. OF TRANSPORTATION
 DIVISION OF HIGHWAYS
 RALEIGH, N.C.

ENGLISH DETAIL DRAWING FOR
GROUND MOUNTED SIGN SUPPORTS

SHEET 2 OF 3
903D10

**REVISED SIGNING
ROADWAY STANDARD DRAWING**

08-MAR-2012 10:05 AM S:\S&D\Standards_Group\NMP\2012 Standard Drawings\Standard Dwg 8-17-11\Revised\903D10_sgn_sht02.dwg support1_Revise.dwg

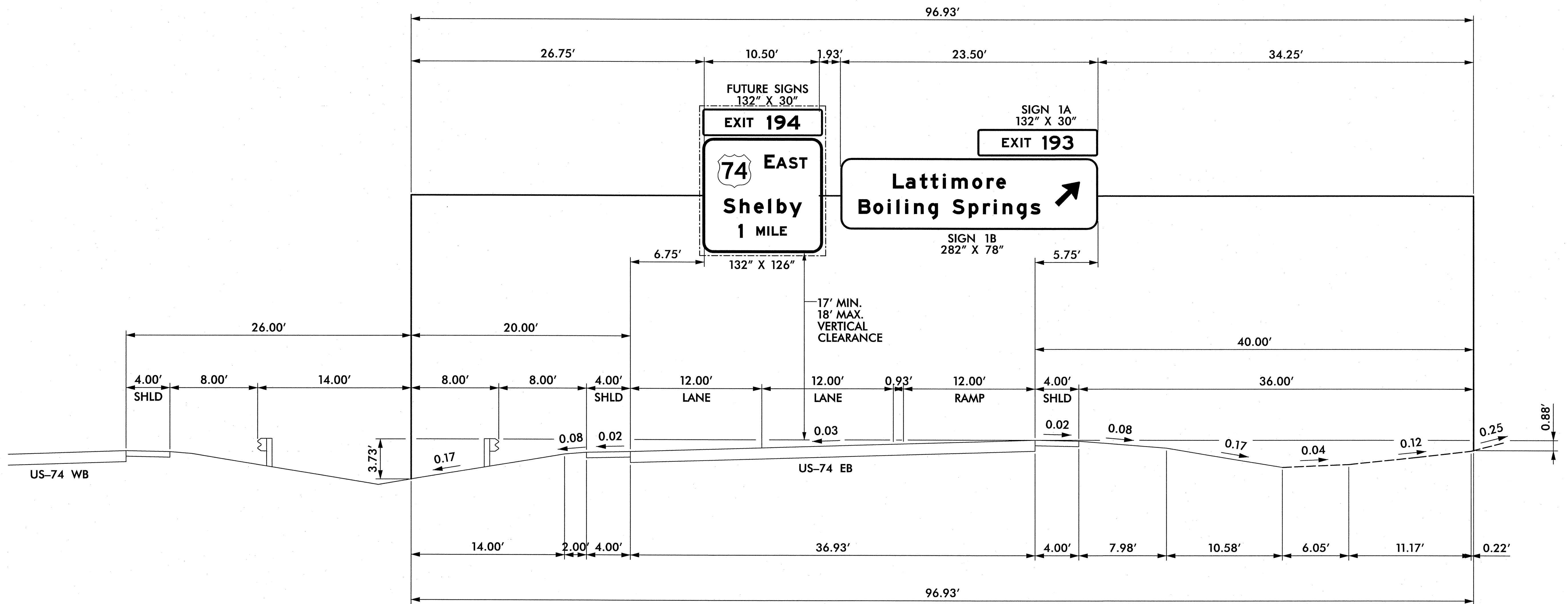

NOTES:

- IF THE CONTRACTOR BIDS ALUMINUM SIGN STRUCTURE, EACH SHALL BE PROVIDED WITH AN APPROVED HIGHWAY TRUSS DAMPER DEVICE IN ACCORDANCE WITH AASHTO SPECIFICATIONS.
- MOUNT SIGNS VERTICALLY CENTERED ON HORIZONTAL MEMBER OF STRUCTURE.
- FIELD VERIFICATION SHALL BE REQUIRED FOR ALL FOOTING ELEVATIONS, PER THE LATEST NCDOT STANDARD SPECIFICATIONS FOR ROADS AND STRUCTURES. PROVIDE FIELD VERIFICATION TO THE SIGNING SECTION.
- THE TOP OF THE FOOTING SHALL EXTEND AT LEAST 6 INCHES AND NOT MORE THAN 24 INCHES ABOVE THE HIGHEST POINT OF THE GROUND SURFACE AT THE FOOTING.
- SIGN HANGERS AND ATTACHMENT HARDWARE SHALL BE PROVIDED AND INSTALLED ON THE ASSEMBLY TO ACCOMMODATE ALL SIGNS SHOWN IN THIS PLAN SHEET.
- DESIGN AND CONSTRUCTION REQUIREMENTS FOR SIGN STRUCTURES SHALL ACCOMMODATE WIND VELOCITY OF 90 M.P.H.

OVERHEAD ASSEMBLY 'A'
STA. 24+67 -L-

APPROVED: *[Signature]*
DATE: 8-28-2012

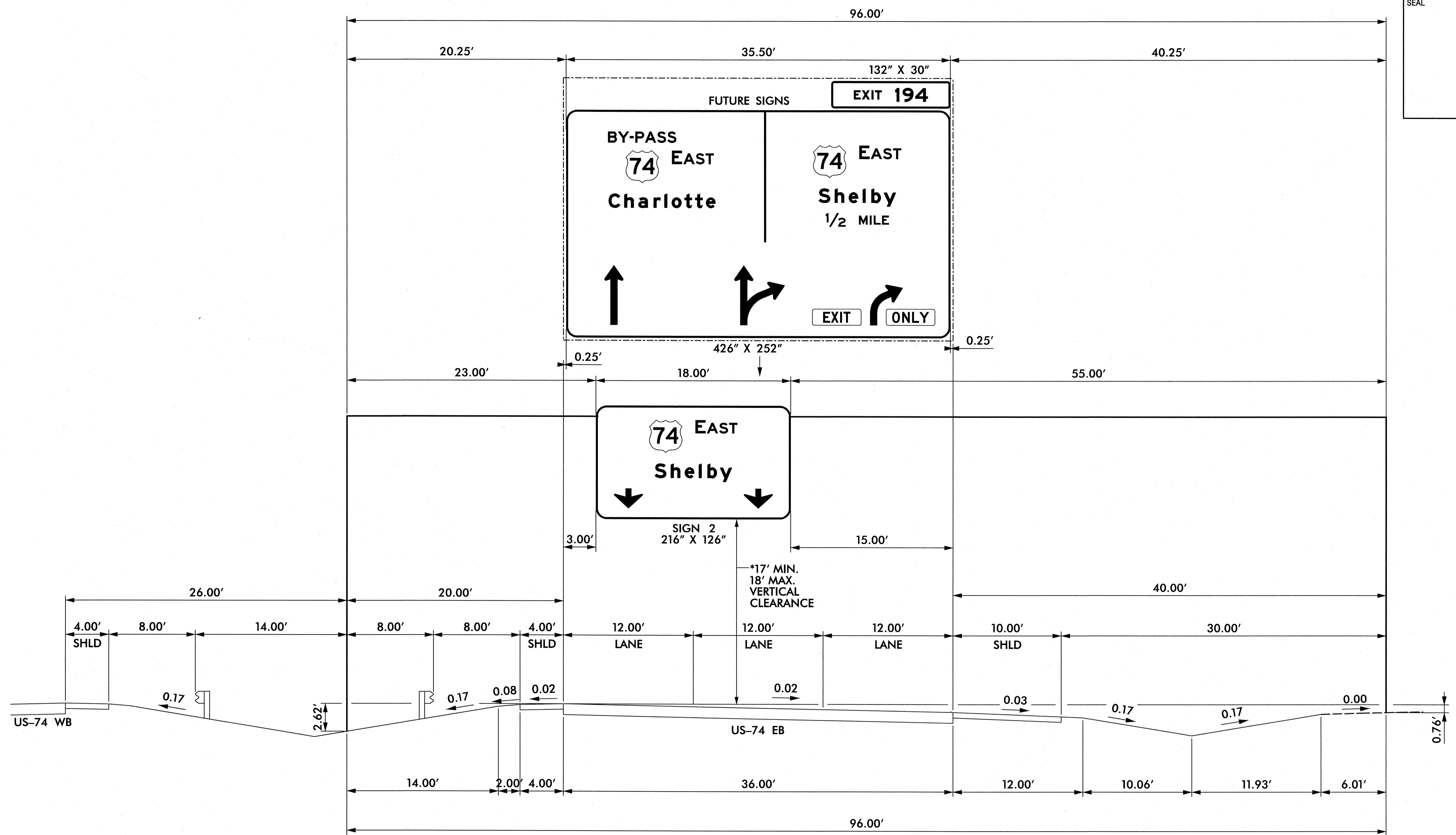

NOTES:

- IF THE CONTRACTOR BIDS ALUMINUM SIGN STRUCTURE, EACH SHALL BE PROVIDED WITH AN APPROVED HIGHWAY TRUSS DAMPER DEVICE IN ACCORDANCE WITH AASHTO SPECIFICATIONS.
- MOUNT SIGNS VERTICALLY CENTERED ON HORIZONTAL MEMBER OF STRUCTURE.
- FIELD VERIFICATION SHALL BE REQUIRED FOR ALL FOOTING ELEVATIONS, PER THE LATEST NCDOT STANDARD SPECIFICATIONS FOR ROADS AND STRUCTURES. PROVIDE FIELD VERIFICATION TO THE SIGNING SECTION.
- THE TOP OF THE FOOTING SHALL EXTEND AT LEAST 6 INCHES AND NOT MORE THAN 24 INCHES ABOVE THE HIGHEST POINT OF THE GROUND SURFACE AT THE FOOTING.
- SIGN HANGERS AND ATTACHMENT HARDWARE SHALL BE PROVIDED AND INSTALLED ON THE ASSEMBLY TO ACCOMMODATE ALL SIGNS SHOWN IN THIS PLAN SHEET.
- DESIGN AND CONSTRUCTION REQUIREMENTS FOR SIGN STRUCTURES SHALL ACCOMMODATE WIND VELOCITY OF 90 M.P.H.

*VERTICAL CLEARANCE TO SIGN 2 AND FUTURE SIGNS SHALL BE 17' MIN AND 18' MAX.

OVERHEAD ASSEMBLY 'B'
STA. 43+20 -L-

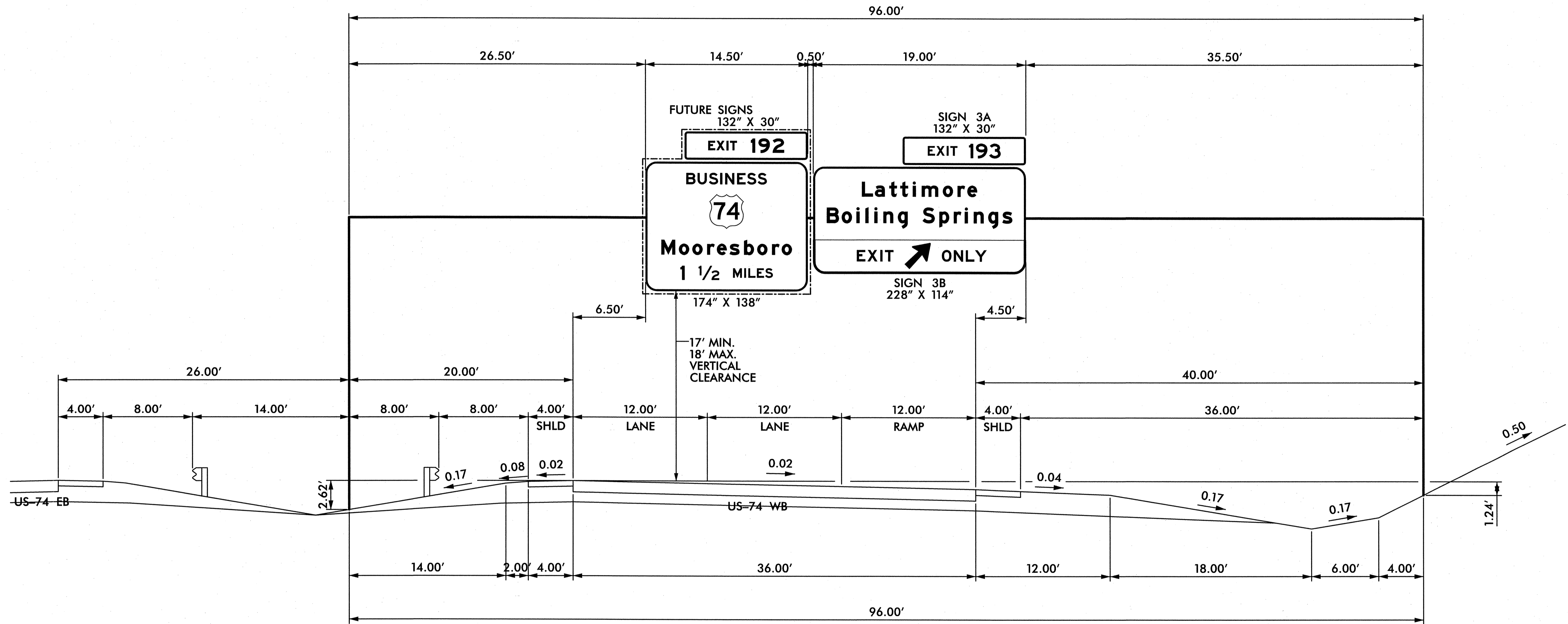

NOTES:

- IF THE CONTRACTOR BIDS ALUMINUM SIGN STRUCTURE, EACH SHALL BE PROVIDED WITH AN APPROVED HIGHWAY TRUSS DAMPER DEVICE IN ACCORDANCE WITH AASHTO SPECIFICATIONS.
- MOUNT SIGNS VERTICALLY CENTERED ON HORIZONTAL MEMBER OF STRUCTURE.
- FIELD VERIFICATION SHALL BE REQUIRED FOR ALL FOOTING ELEVATIONS, PER THE LATEST NCDOT STANDARD SPECIFICATIONS FOR ROADS AND STRUCTURES. PROVIDE FIELD VERIFICATION TO THE SIGNING SECTION.
- THE TOP OF THE FOOTING SHALL EXTEND AT LEAST 6 INCHES AND NOT MORE THAN 24 INCHES ABOVE THE HIGHEST POINT OF THE GROUND SURFACE AT THE FOOTING.
- SIGN HANGERS AND ATTACHMENT HARDWARE SHALL BE PROVIDED AND INSTALLED ON THE ASSEMBLY TO ACCOMMODATE ALL SIGNS SHOWN IN THIS PLAN SHEET.
- DESIGN AND CONSTRUCTION REQUIREMENTS FOR SIGN STRUCTURES SHALL ACCOMMODATE WIND VELOCITY OF 90 M.P.H.

OVERHEAD ASSEMBLY 'C'
STA. 44+50 -L-

APPROVED: *[Signature]*
 DATE: 10-30-2012

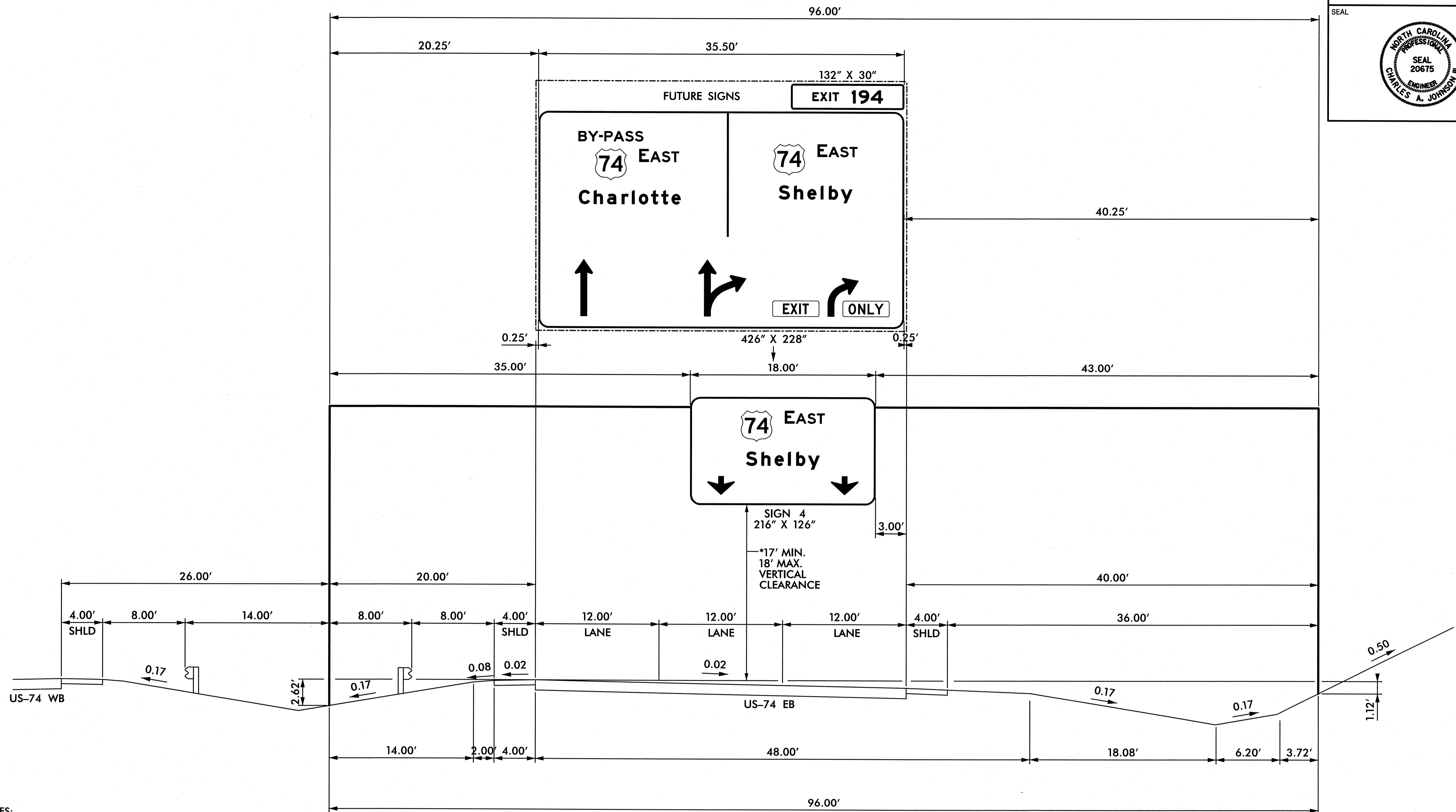
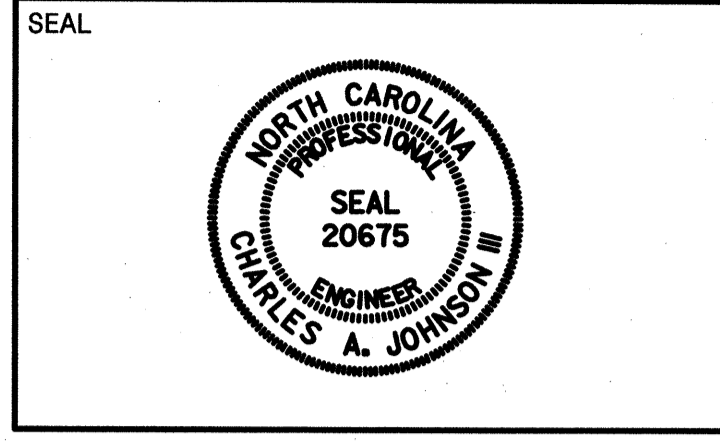

NOTES:

- IF THE CONTRACTOR BIDS ALUMINUM SIGN STRUCTURE, EACH SHALL BE PROVIDED WITH AN APPROVED HIGHWAY TRUSS DAMPER DEVICE IN ACCORDANCE WITH AASHTO SPECIFICATIONS.
- MOUNT SIGNS VERTICALLY CENTERED ON HORIZONTAL MEMBER OF STRUCTURE.
- FIELD VERIFICATION SHALL BE REQUIRED FOR ALL FOOTING ELEVATIONS, PER THE LATEST NCDOT STANDARD SPECIFICATIONS FOR ROADS AND STRUCTURES. PROVIDE FIELD VERIFICATION TO THE SIGNING SECTION.
- THE TOP OF THE FOOTING SHALL EXTEND AT LEAST 6 INCHES AND NOT MORE THAN 24 INCHES ABOVE THE HIGHEST POINT OF THE GROUND SURFACE AT THE FOOTING.
- SIGN HANGERS AND ATTACHMENT HARDWARE SHALL BE PROVIDED AND INSTALLED ON THE ASSEMBLY TO ACCOMMODATE ALL SIGNS SHOWN IN THIS PLAN SHEET.
- DESIGN AND CONSTRUCTION REQUIREMENTS FOR SIGN STRUCTURES SHALL ACCOMMODATE WIND VELOCITY OF 90 M.P.H.

*VERTICAL CLEARANCE TO SIGN 5 AND FUTURE SIGNS SHALL BE 17' MIN AND 18' MAX.

OVERHEAD ASSEMBLY 'D'
STA. 74+50 -L-

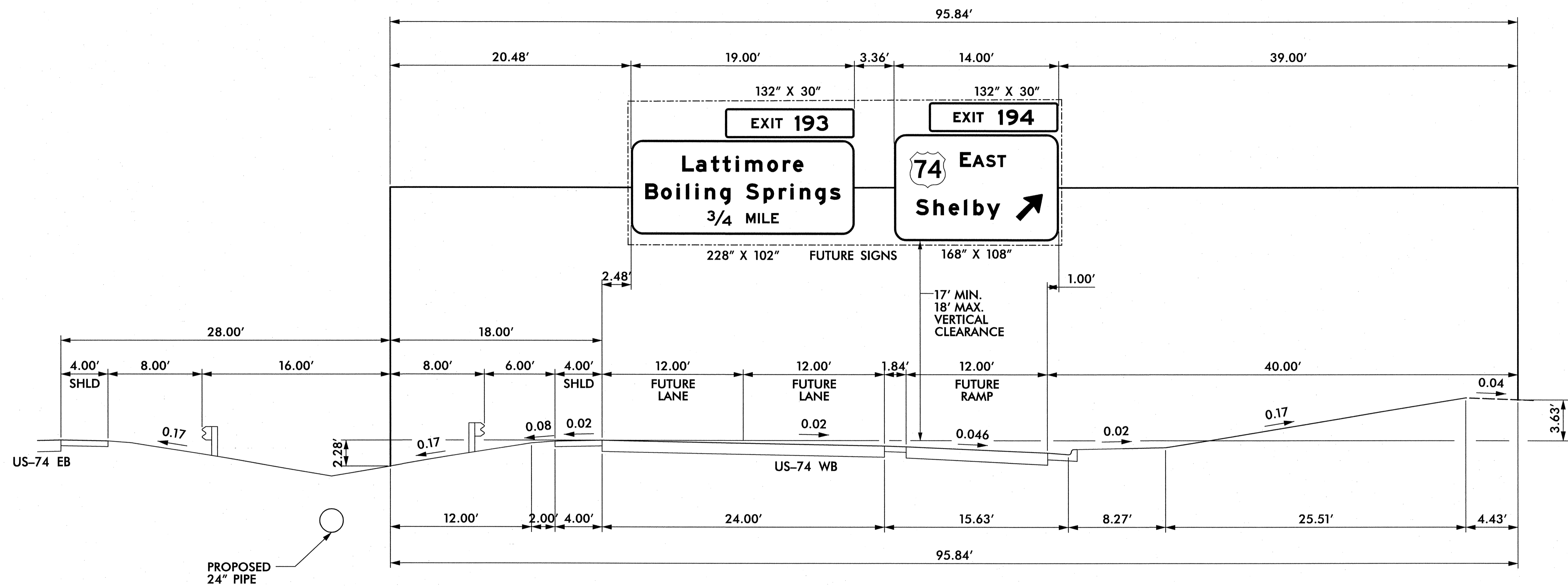

NOTES:

1. IF THE CONTRACTOR BIDS ALUMINUM SIGN STRUCTURE, EACH SHALL BE PROVIDED WITH AN APPROVED HIGHWAY TRUSS DAMPER DEVICE IN ACCORDANCE WITH AASHTO SPECIFICATIONS.
2. MOUNT SIGNS VERTICALLY CENTERED ON HORIZONTAL MEMBER OF STRUCTURE.
3. FIELD VERIFICATION SHALL BE REQUIRED FOR ALL FOOTING ELEVATIONS, PER THE LATEST NCDOT STANDARD SPECIFICATIONS FOR ROADS AND STRUCTURES. PROVIDE FIELD VERIFICATION TO THE SIGNING SECTION.
4. THE TOP OF THE FOOTING SHALL EXTEND AT LEAST 6 INCHES AND NOT MORE THAN 24 INCHES ABOVE THE HIGHEST POINT OF THE GROUND SURFACE AT THE FOOTING.
5. SIGN HANGERS AND ATTACHMENT HARDWARE SHALL BE PROVIDED AND INSTALLED ON THE ASSEMBLY TO ACCOMMODATE ALL SIGNS SHOWN IN THIS PLAN SHEET.
6. DESIGN AND CONSTRUCTION REQUIREMENTS FOR SIGN STRUCTURES SHALL ACCOMMODATE WIND VELOCITY OF 90 M.P.H.

OVERHEAD ASSEMBLY 'E'
STA. 78+00 -L-

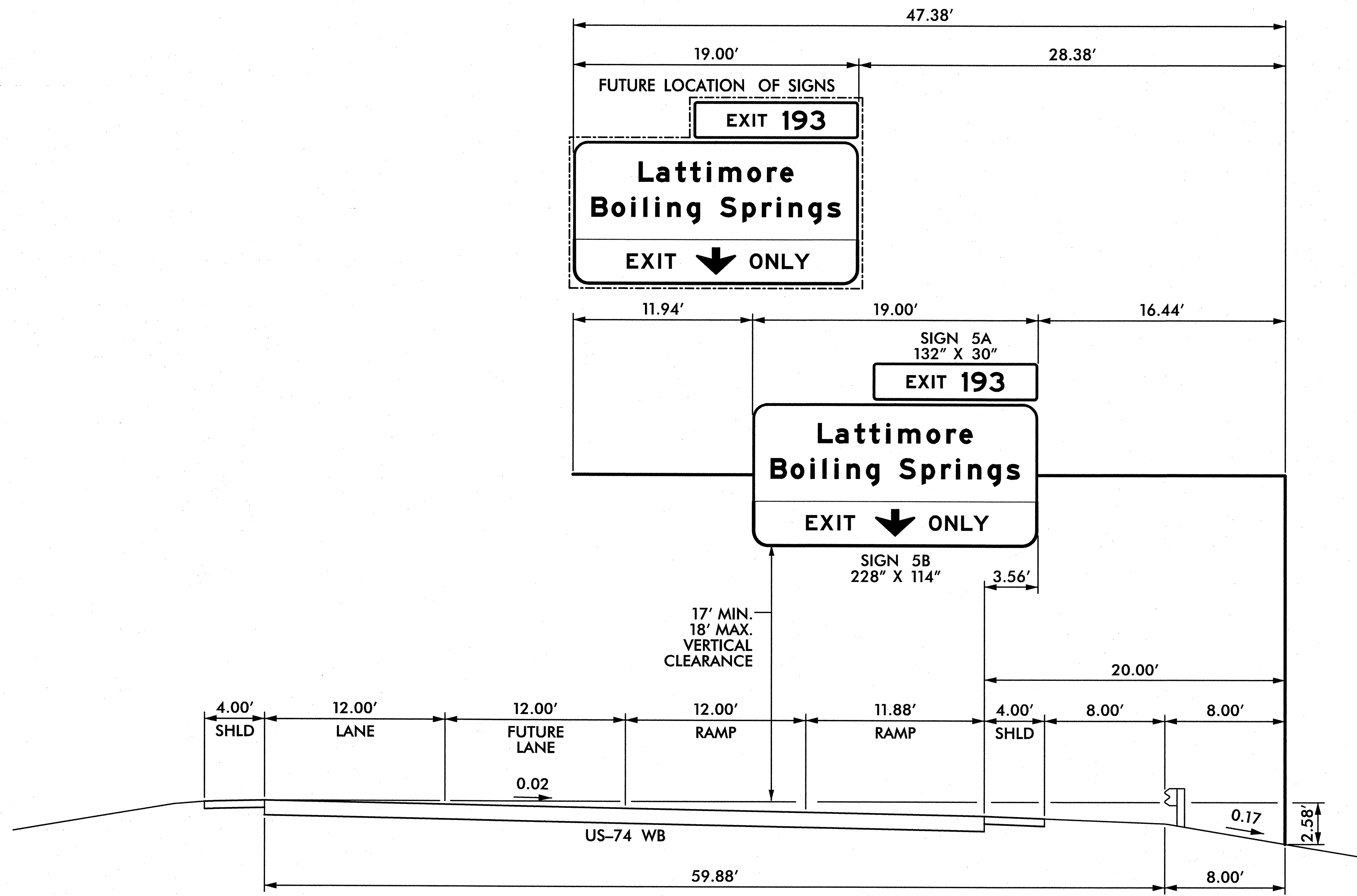

NOTES:

1. IF THE CONTRACTOR BIDS ALUMINUM SIGN STRUCTURE, EACH SHALL BE PROVIDED WITH AN APPROVED HIGHWAY TRUSS DAMPER DEVICE IN ACCORDANCE WITH AASHTO SPECIFICATIONS.
2. MOUNT SIGNS VERTICALLY CENTERED ON HORIZONTAL MEMBER OF STRUCTURE.
3. FIELD VERIFICATION SHALL BE REQUIRED FOR ALL FOOTING ELEVATIONS, PER THE LATEST NCDOT STANDARD SPECIFICATIONS FOR ROADS AND STRUCTURES. PROVIDE FIELD VERIFICATION TO THE SIGNING SECTION.
4. THE TOP OF THE FOOTING SHALL EXTEND AT LEAST 6 INCHES AND NOT MORE THAN 24 INCHES ABOVE THE HIGHEST POINT OF THE GROUND SURFACE AT THE FOOTING.
5. SIGN HANGERS AND ATTACHMENT HARDWARE SHALL BE PROVIDED AND INSTALLED ON THE ASSEMBLY TO ACCOMMODATE ALL SIGNS SHOWN IN THIS PLAN SHEET.
6. DESIGN AND CONSTRUCTION REQUIREMENTS FOR SIGN STRUCTURES SHALL ACCOMMODATE WIND VELOCITY OF 90 M.P.H.

OVERHEAD ASSEMBLY 'F'
STA. 62+00 -L-

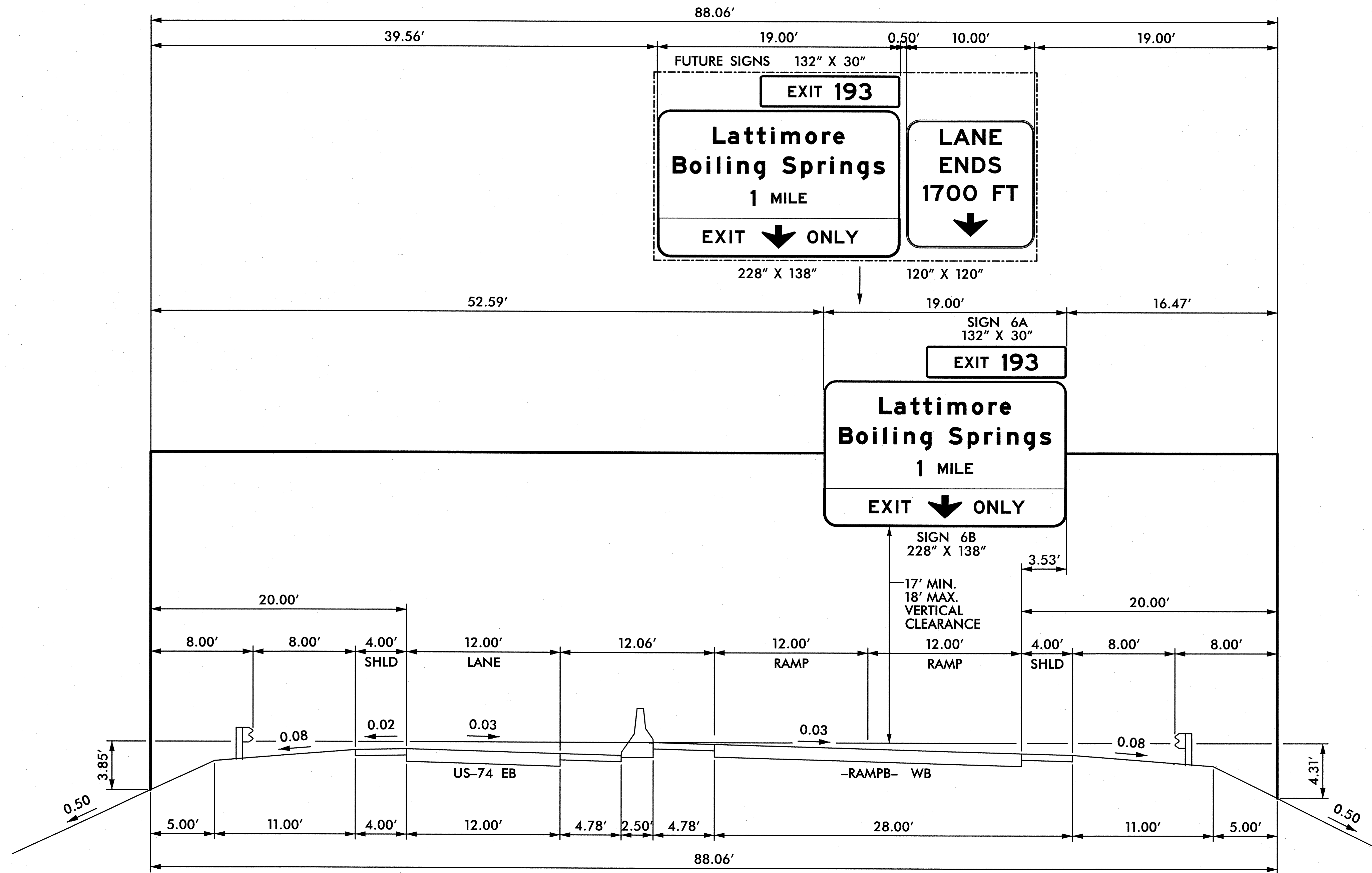

NOTES:

1. IF THE CONTRACTOR BIDS ALUMINUM SIGN STRUCTURE, EACH SHALL BE PROVIDED WITH AN APPROVED HIGHWAY TRUSS DAMPER DEVICE IN ACCORDANCE WITH AASHTO SPECIFICATIONS.
2. MOUNT SIGNS VERTICALLY CENTERED ON HORIZONTAL MEMBER OF STRUCTURE.
3. FIELD VERIFICATION SHALL BE REQUIRED FOR ALL FOOTING ELEVATIONS, PER THE LATEST NCDOT STANDARD SPECIFICATIONS FOR ROADS AND STRUCTURES. PROVIDE FIELD VERIFICATION TO THE SIGNING SECTION.
4. THE TOP OF THE FOOTING SHALL EXTEND AT LEAST 6 INCHES AND NOT MORE THAN 24 INCHES ABOVE THE HIGHEST POINT OF THE GROUND SURFACE AT THE FOOTING.
5. SIGN HANGERS AND ATTACHMENT HARDWARE SHALL BE PROVIDED AND INSTALLED ON THE ASSEMBLY TO ACCOMMODATE ALL SIGNS SHOWN IN THIS PLAN SHEET.
6. DESIGN AND CONSTRUCTION REQUIREMENTS FOR SIGN STRUCTURES SHALL ACCOMMODATE WIND VELOCITY OF 90 M.P.H.

**OVERHEAD ASSEMBLY 'G'
STA. 40+00 - RAMPB-**

SIGN NUMBER: 1A,3A,5A,6A BACKG COLOR: Green
 TYPE: B (OVHD) COPY COLOR: White
 QUANTITY: 4
 SIGN WIDTH: 11'-0"
 HEIGHT: 2'-6"
 TOTAL AREA: 27.5 Sq.Ft.
 BORDER TYPE: FLUSH
 RECESS: 0"
 WIDTH: 2"
 RADII: 3"
 NO. Z BARS: 2
 LENGTH: 124.0
 MAT'L: 0.125" ALUMINUM

DESIGN BY: TRT CHECKED BY: ADK/CAJ
 PROJECT ID: R-2707AA DIV: 12 DATE: August 2012

NOTES:
 1. Legend and border shall be direct applied Grade A reflective sheeting.
 2. Background shall be Grade C reflective sheeting.

LETTER POSITIONS

Letter spacings are to start of next letter

	E	X	I	T	Series/Size		
	27	9.2	11.1	3.8	7.5	73.4	E 2000
							31.6
							E 2000
							33.9

SIGN NUMBER: 1B BACKG COLOR: Green
 TYPE: A (OVHD) COPY COLOR: White
 QUANTITY: 1
 SIGN WIDTH: 23'-6"
 HEIGHT: 6'-6"
 TOTAL AREA: 152.8 Sq.Ft.
 BORDER TYPE: FLUSH
 RECESS: 0"
 WIDTH: 2"
 RADII: 12"
 NO. Z BARS: 2
 LENGTH: 274.0
 MAT'L: 0.125" ALUMINUM

DESIGN BY: TRT CHECKED BY: ADK/CAJ
 PROJECT ID: R-2707AA DIV: 12 DATE: August 2012

NOTES:
 1. Legend and border shall be direct applied Grade A reflective sheeting.
 2. Background shall be Grade C reflective sheeting.
 3. Center arrow(s) vertically on sign.

LETTER POSITIONS

Letter spacings are to start of next letter

	L	a	t	t	i	m	o	r	e	Series/Size		
	57.5	13.9	15.4	11.8	13.4	9.6	22.6	15.8	10.4	10.6	101	EM 2000
												123.5
												EM 2000
												198.9

SIGN NUMBER: 2,4 BACKG COLOR: Green
 TYPE: A (OVHD) COPY COLOR: White
 QUANTITY: 2
 SIGN WIDTH: 18'-0"
 HEIGHT: 10'-6"
 TOTAL AREA: 189.0 Sq.Ft.
 BORDER TYPE: FLUSH
 RECESS: 0"
 WIDTH: 2"
 RADII: 12"
 NO. Z BARS: 3
 LENGTH: 208.0
 MAT'L: 0.125" ALUMINUM

DESIGN BY: TRT CHECKED BY: ADK/CAJ
 PROJECT ID: R-2707AA DIV: 12 DATE: August 2012

NOTES:
 1. Legend and border shall be direct applied Grade A reflective sheeting.
 2. Shields shall be Grade C reflective sheeting on 0.032" aluminum and demountable.
 3. Background shall be Grade C reflective sheeting.

LETTER POSITIONS

Letter spacings are to start of next letter

	E	A	S	T	Series/Size			
	110.3	11.2	1.5	13.6	11	9	59.3	E 2000
								46.4
								EM 2000
								85.9

SIGN NUMBER: 3B BACKG COLOR: Green/Yellow
 TYPE: A (OVHD) COPY COLOR: White/Black
 QUANTITY: 1
 SIGN WIDTH: 19'-0"
 HEIGHT: 9'-6"
 TOTAL AREA: 180.5 Sq.Ft.
 BORDER TYPE: FLUSH
 RECESS: 0"
 WIDTH: 2"
 RADII: 12"
 NO. Z BARS: 3
 LENGTH: 220.0
 MAT'L: 0.125" ALUMINUM

DESIGN BY: TRT CHECKED BY: ADK/CAJ
 PROJECT ID: R-2707AA DIV: 12 DATE: August 2012

NOTES:
 1. Legend and border shall be direct applied Grade A reflective sheeting.
 2. Background shall be Grade C reflective sheeting.
 3. Bottom panel shall be yellow Grade C sheeting. Legend and border shall be direct applied black non-reflective sheeting.

LETTER POSITIONS

Letter spacings are to start of next letter

	L	a	t	t	i	m	o	r	e	Series/Size		
	52.2	13.9	15.4	11.8	13.4	9.6	22.6	15.8	10.4	10.6	52.2	EM 2000
												123.5
												EM 2000
												198.9
												E 2000
												39.2
												E 2000
												47.9

SIGN NUMBER: 5B BACKG COLOR: Green/Yellow
 TYPE: A (OHVD) COPY COLOR: White/Black
 QUANTITY: 1
 SIGN WIDTH: 19'-0" HEIGHT: 9'-6"
 TOTAL AREA: 180.5 Sq.Ft.
 BORDER TYPE: FLUSH
 RECESS: 0"
 WIDTH: 2"
 RADII: 12"
 NO. Z BARS: 3
 LENGTH: 220.0
 MAT'L: 0.125" ALUMINUM

DESIGN BY: TRT CHECKED BY: ADK/CAJ
 PROJECT ID: R-2707AA DIV: 12 DATE: August 2012

NOTES:
 1. Legend and border shall be direct applied Grade A reflective sheeting.
 2. Background shall be Grade C reflective sheeting.
 3. Bottom panel shall be yellow Grade C sheeting. Legend and border shall be direct applied black non-reflective sheeting.

BORDER R=12" TH=2" YELLOW PANEL BORDER R=12" TH=1.5" IN=0.5" Spacing Factor is 1 unless specified otherwise Saping Factor of "EXIT" is 1.4.

LETTER POSITIONS

Letter spacings are to start of next letter

Series/Size	Text Length
EM 2000	123.5
EM 2000	198.9
E 2000	39.2
E 2000	47.9

SIGN NUMBER: 6B BACKG COLOR: Green/Yellow
 TYPE: A
 QUANTITY: 1
 SIGN WIDTH: 19'-0" HEIGHT: 11'-6"
 TOTAL AREA: 218.5 Sq.Ft.
 BORDER TYPE: FLUSH
 RECESS: 0"
 WIDTH: 2"
 RADII: 12"
 NO. Z BARS: 3
 LENGTH: 220.0
 MAT'L: 0.125" ALUMINUM

DESIGN BY: TRT CHECKED BY: ADK/CAJ
 PROJECT ID: R-2707AA DIV: 12 DATE: August 2012

NOTES:
 1. Legend and border shall be direct applied Grade A reflective sheeting.
 2. Background shall be Grade C reflective sheeting.
 3. Bottom panel shall be yellow Grade C sheeting. Legend and border shall be direct applied black non-reflective sheeting.

BORDER R=12" TH=2" YELLOW PANEL BORDER R=12" TH=1.5" IN=0.5" Spacing Factor is 1 unless specified otherwise Saping Factor of "EXIT" is 1.4.

LETTER POSITIONS

Letter spacings are to start of next letter

Series/Size	Text Length
EM 2000	123.5
EM 2000	198.9
E 2000	52.6
E 2000	39.2
E 2000	47.9

SIGN NUMBER: 101A,102A BACKG COLOR: Green
 TYPE: B COPY COLOR: White
 QUANTITY: 2
 SIGN WIDTH: 11'-0" HEIGHT: 2'-6"
 TOTAL AREA: 27.5 Sq.Ft.
 BORDER TYPE: FLUSH
 RECESS: 0"
 WIDTH: 2"
 RADII: 3"
 NO. Z BARS: 2
 LENGTH: 124.0
 MAT'L: 0.125" ALUMINUM

DESIGN BY: TRT CHECKED BY: ADK/CAJ
 PROJECT ID: R-2707AA DIV: 12 DATE: August 2012

NOTES:
 1. Legend and border shall be direct applied Grade C reflective sheeting.
 2. Background shall be Grade C reflective sheeting.

BORDER R=3" TH=2" Spacing Factor is 1 unless specified otherwise

LETTER POSITIONS

Letter spacings are to start of next letter

Series/Size	Text Length
E 2000	31.6
E 2000	33.9

SIGN NUMBER: 101B BACKG COLOR: Green
 TYPE: A COPY COLOR: White
 QUANTITY: 1
 SIGN WIDTH: 19'-0" HEIGHT: 8'-6"
 TOTAL AREA: 161.5 Sq.Ft.
 BORDER TYPE: FLUSH
 RECESS: 0"
 WIDTH: 2"
 RADII: 12"
 NO. Z BARS: 3
 LENGTH: 220.0
 MAT'L: 0.125" ALUMINUM

DESIGN BY: TRT CHECKED BY: ADK/CAJ
 PROJECT ID: R-2707AA DIV: 12 DATE: August 2012

NOTES:
 1. Legend and border shall be direct applied Grade C reflective sheeting.
 2. Background shall be Grade C reflective sheeting.
 3. Support spacing is 7.60' and 7.60'.

BORDER R=12" TH=2" Spacing Factor is 1 unless specified otherwise

LETTER POSITIONS

Letter spacings are to start of next letter

Series/Size	Text Length
EM 2000	123.5
EM 2000	198.9
E 2000	52.6

APPROVED: *[Signature]*

DATE: 10-30-2012

SEAL

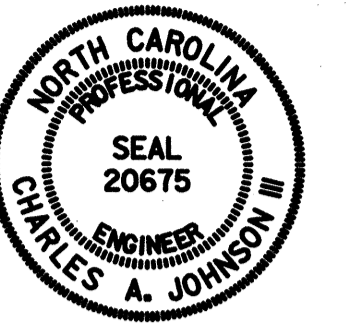

SIGN NUMBER: 102B TYPE: A QUANTITY: 1 SIGN WIDTH: 19'-0" HEIGHT: 8'-6" TOTAL AREA: 161.5 Sq.Ft. BORDER TYPE: FLUSH RECESS: 0" WIDTH: 2" RADIUS: 12" NO. Z BARS: 3 LENGTH: 220.0	BACKG COLOR: Green COPY COLOR: White SYMBOL X Y WID HT MAT'L: 0.125" ALUMINUM	DESIGN BY: TRT PROJECT ID: R-2707AA CHECKED BY: ADK/CAJ DIV: 12 DATE: August 2012
------------------------------------------------------------------------------------------------------------------------------------------------------------------------------------------------------------------	----------------------------------------------------------------------------------------	-----------------------------------------------------------------------------------------------

Spacing Factor is 1 unless specified otherwise

LETTER POSITIONS

Letter spacings are to start of next letter		Series/Size
L a t t i m o r e	EM 2000	123.5
B o i l i n g s	EM 2000	198.9
1/2 M I L E	E 2000	70.1

SIGN NUMBER: 103 TYPE: B QUANTITY: 1 SIGN WIDTH: 9'-0" HEIGHT: 3'-0" TOTAL AREA: 27.0 Sq.Ft. BORDER TYPE: FLUSH RECESS: 0" WIDTH: 1" RADIUS: 3" NO. Z BARS: 2 LENGTH: 100.0	BACKG COLOR: Green COPY COLOR: White SYMBOL X Y WID HT MAT'L: 0.125" ALUMINUM	DESIGN BY: ADK PROJECT ID: R-2707AA CHECKED BY: EAH/CAJ DIV: 12 DATE: Sept 2012
--------------------------------------------------------------------------------------------------------------------------------------------------------------------------------------------------------------	----------------------------------------------------------------------------------------	---------------------------------------------------------------------------------------------

Spacing Factor is 1 unless specified otherwise

LETTER POSITIONS

Letter spacings are to start of next letter		Series/Size
R u t h e r f o r d t o n	D 2000	65.2
A s h e v i l l e	D 2000	9.2
19	D 2000	43
71	D 2000	8.8

SIGN NUMBER: 104,105 TYPE: A QUANTITY: 2 SIGN WIDTH: 14'-6" HEIGHT: 7'-6" TOTAL AREA: 108.8 Sq.Ft. BORDER TYPE: FLUSH RECESS: 0" WIDTH: 2" RADIUS: 12" NO. Z BARS: 3 LENGTH: 166.0	BACKG COLOR: Green COPY COLOR: White SYMBOL X Y WID HT MAT'L: 0.125" ALUMINUM	DESIGN BY: TRT PROJECT ID: R-2707AA CHECKED BY: ADK/CAJ DIV: 12 DATE: August 2012
---------------------------------------------------------------------------------------------------------------------------------------------------------------------------------------------------------------------	----------------------------------------------------------------------------------------	-----------------------------------------------------------------------------------------------

Spacing Factor is 1 unless specified otherwise

LETTER POSITIONS

Letter spacings are to start of next letter		Series/Size
G a r d n e r	EM 2000	148.2
U n i v e r s i t y	EM 2000	110.7
E X I T	E 2000	79.5

SIGN NUMBER: 106 TYPE: B QUANTITY: 1 SIGN WIDTH: 10'-0" HEIGHT: 3'-0" TOTAL AREA: 30.0 Sq.Ft. BORDER TYPE: FLUSH RECESS: 0" WIDTH: 1" RADIUS: 3" NO. Z BARS: 2 LENGTH: 112.0	BACKG COLOR: Green COPY COLOR: White SYMBOL X Y WID HT MAT'L: 0.125" ALUMINUM	DESIGN BY: TRT PROJECT ID: R-2707AA CHECKED BY: ADK/CAJ DIV: 12 DATE: August 2012
---------------------------------------------------------------------------------------------------------------------------------------------------------------------------------------------------------------	----------------------------------------------------------------------------------------	-----------------------------------------------------------------------------------------------

Spacing Factor is 1 unless specified otherwise

LETTER POSITIONS

Letter spacings are to start of next letter		Series/Size
S h e l b y	D 2000	32.7
K i n g s M o u n t a i n	D 2000	76.2
6	D 2000	5.4
20	D 2000	12.7

APPROVED: [Signature] DATE: 10-30-2012

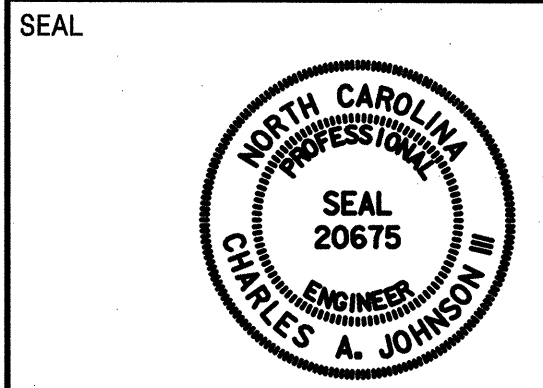

SIGN NUMBER: 201,202A BACKG COLOR: Green
 TYPE: A COPY COLOR: White
 QUANTITY: 2
 SIGN WIDTH: 8'-0" HEIGHT: 5'-0"
 TOTAL AREA: 40.0 Sq.Ft.
 BORDER TYPE: FLUSH RECESS: 0"
 WIDTH: 1.5" RADII: 8"
 NO. Z BARS: 2 LENGTH: 88.0
 MAT'L: 0.125" ALUMINUM

DESIGN BY: ADK CHECKED BY: ADK/CAJ
 PROJECT ID: R-2707AA DIV: 12 DATE: August 2012

BORDER R=6" TH=1.5"

Spacing Factor for "EXIT" is 2.25
 Spacing Factor is 1 unless specified otherwise

LETTER POSITIONS

Letter spacings are to start of next letter

Series/Size	Text Length
E 2000	44.4
E 2000	40.7

SIGN NUMBER: 202B BACKG COLOR: Yellow
 TYPE: B COPY COLOR: Black
 QUANTITY: 1
 SIGN WIDTH: 8'-0" HEIGHT: 2'-0"
 TOTAL AREA: 16.0 Sq.Ft.
 BORDER TYPE: FLUSH RECESS: 0.88"
 WIDTH: 0.38" RADII: 1.5"
 NO. Z BARS: 2 LENGTH: 88.0
 MAT'L: 0.125" ALUMINUM

DESIGN BY: TRT CHECKED BY: ADK/CAJ
 PROJECT ID: R-2707AA DIV: 12 DATE: August 2012

BORDER R=1.5" TH=0.38" IN=0.88"

Spacing Factor is 1 unless specified otherwise

LETTER POSITIONS

Letter spacings are to start of next letter

Series/Size	Text Length
E 2000	58.7

SIGN NUMBER: 301,302 BACKG COLOR: Green
 TYPE: D COPY COLOR: White
 QUANTITY: 2
 SIGN WIDTH: 5'-0" HEIGHT: 2'-6"
 TOTAL AREA: 12.5 Sq.Ft.
 BORDER TYPE: FLUSH RECESS: 0"
 WIDTH: 0.88" RADII: 2.25"
 NO. Z BARS: 2 LENGTH: 88.0
 MAT'L: 0.125" ALUMINUM

DESIGN BY: ADK CHECKED BY: TRT/CAJ
 PROJECT ID: R-2707AA DIV: 12 DATE: August 2012

BORDER R=2.25" TH=0.88"

Spacing Factor is 1 unless specified otherwise

LETTER POSITIONS

Letter spacings are to start of next letter

Series/Size	Text Length
D 2000	41.7
D 2000	20.4

SIGN NUMBER: 303,308 BACKG COLOR: Green
 TYPE: D COPY COLOR: White
 QUANTITY: 2
 SIGN WIDTH: 7'-0" HEIGHT: 2'-6"
 TOTAL AREA: 17.5 Sq.Ft.
 BORDER TYPE: FLUSH RECESS: 0"
 WIDTH: 0.75" RADII: 2.25"
 NO. Z BARS: 2 LENGTH: 88.0
 MAT'L: 0.125" ALUMINUM

DESIGN BY: TRT CHECKED BY: ADK/CAJ
 PROJECT ID: R-2707AA DIV: 12 DATE: August 2012

BORDER R=2.25" TH=0.75"

Spacing Factor is 1 unless specified otherwise

LETTER POSITIONS

Letter spacings are to start of next letter

Series/Size	Text Length
D 2000	53.7
D 2000	35.8

APPROVED: *[Signature]*
DATE: 10-30-2012

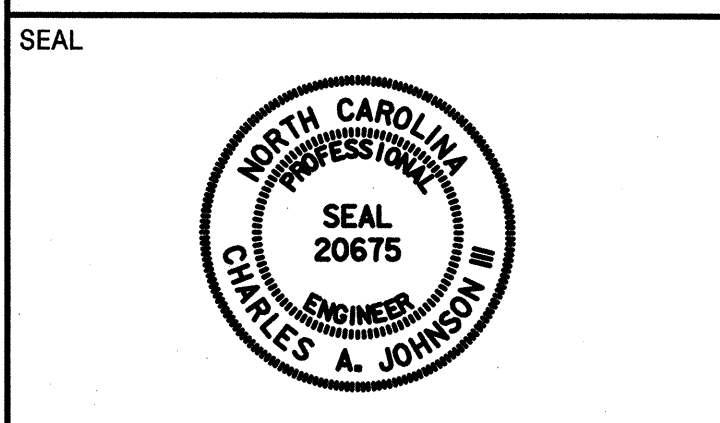

SIGN NUMBER: 304,309 BACKG COLOR: Green
TYPE: D COPY COLOR: White
QUANTITY: 2

SYMBOL	X	Y	WID	HT
Arrow Left	17.6	19.3	6	9
Arrow Right	68.6	4.7	6	9

SIGN WIDTH: 7'-0"
HEIGHT: 2'-6"
TOTAL AREA: 17.5 Sq.Ft.

BORDER TYPE: FLUSH
RECESS: 0"
WIDTH: 0.75"
RADI: 2.25"

NO. Z BARS:
LENGTH:

DESIGN BY: ADK CHECKED BY: TRT/CAJ
PROJECT ID: R-2707AA DIV: 12 DATE: August 2012

BORDER R=2.25" TH=0.75"

Spacing Factor is 1 unless specified otherwise

LETTER POSITIONS

Letter spacings are to start of next letter

Letter	Series/Size	Text Length
L a t t i m o r e	D 2000	33.7
B o i l i n g s p r i n g s	D 2000	56.3

SIGN NUMBER: 305 BACKG COLOR: Green
TYPE: D COPY COLOR: White
QUANTITY: 1

SYMBOL	X	Y	WID	HT
Arrow Straight	7.9	17.8	6	9
Arrow Left	10.2	4.8	6	9

SIGN WIDTH: 5'-0"
HEIGHT: 2'-6"
TOTAL AREA: 12.5 Sq.Ft.

BORDER TYPE: FLUSH
RECESS: 0"
WIDTH: 0.75"
RADI: 2.25"

NO. Z BARS:
LENGTH:

DESIGN BY: ADK CHECKED BY: EAH/CAJ
PROJECT ID: R-2707AA DIV: 12 DATE: Sept 2012

BORDER R=2.25" TH=0.75"

Spacing Factor is 1 unless specified otherwise

LETTER POSITIONS

Letter spacings are to start of next letter

Letter	Series/Size	Text Length
A s h e v i l l e	D 2000	32.2
S h e l b y	D 2000	24.5

SIGN NUMBER: 306 BACKG COLOR: Green
TYPE: D COPY COLOR: White
QUANTITY: 1

SYMBOL	X	Y	WID	HT
Arrow Left	6.4	6	6	9

SIGN WIDTH: 5'-0"
HEIGHT: 1'-6"
TOTAL AREA: 7.5 Sq.Ft.

BORDER TYPE: FLUSH
RECESS: 0"
WIDTH: 0.75"
RADI: 2.25"

NO. Z BARS:
LENGTH:

DESIGN BY: ADK CHECKED BY: EAH/CAJ
PROJECT ID: R-2707AA DIV: 12 DATE: Sept 2012

BORDER R=2.25" TH=0.75"

Spacing Factor is 1 unless specified otherwise

LETTER POSITIONS

Letter spacings are to start of next letter

Letter	Series/Size	Text Length
A s h e v i l l e	D 2000	32.2

SIGN NUMBER: 307 BACKG COLOR: Green
TYPE: D COPY COLOR: White
QUANTITY: 1

SYMBOL	X	Y	WID	HT
Arrow Straight	11.7	17.7	6	9
Arrow Right	44.6	4.7	6	9

SIGN WIDTH: 5'-0"
HEIGHT: 2'-6"
TOTAL AREA: 12.5 Sq.Ft.

BORDER TYPE: FLUSH
RECESS: 0"
WIDTH: 0.75"
RADI: 2.25"

NO. Z BARS:
LENGTH:

DESIGN BY: ADK CHECKED BY: EAH/CAJ
PROJECT ID: R-2707AA DIV: 12 DATE: Sept 2012

BORDER R=2.25" TH=0.75"

Spacing Factor is 1 unless specified otherwise

LETTER POSITIONS

Letter spacings are to start of next letter

Letter	Series/Size	Text Length
S h e l b y	D 2000	24.5
A s h e v i l l e	D 2000	32.2



SIGN NUMBER: 310 BACKG COLOR: Green
 TYPE: D COPY COLOR: White
 QUANTITY: 1
 SIGN WIDTH: 4'-6" HEIGHT: 1'-6"
 TOTAL AREA: 6.8 Sq.Ft.
 BORDER TYPE: FLUSH RECESS: 0"
 WIDTH: 0.75" RADII: 2.25"
 NO. Z BARS: LENGTH:

SYMBOL	X	Y	WID	HT
Arrow Right	37.8	6	6	9

MAT'L: 0.125" ALUMINUM

DESIGN BY: TRT CHECKED BY: ADK/CAJ
 PROJECT ID: R-2707AA DIV: 12 DATE: August 2012

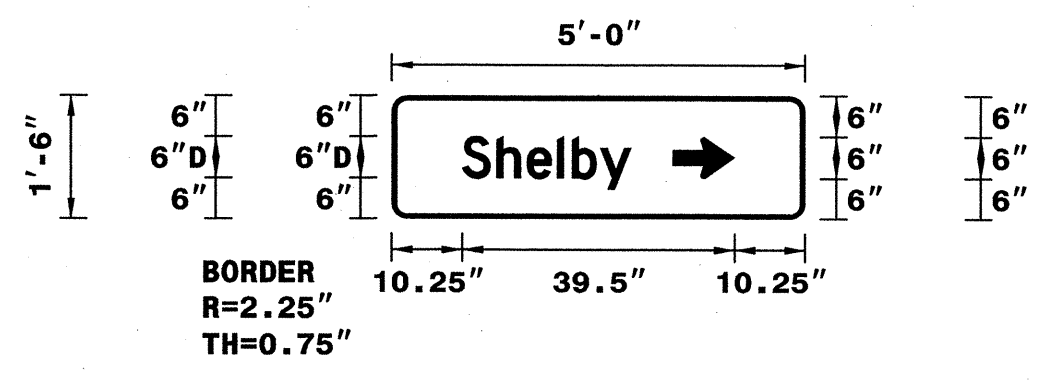

Spacing Factor is 1 unless specified otherwise

- NOTES:
- 1. Legend and border shall be direct applied Grade C reflective sheeting.
 - 2. Background shall be Grade C reflective sheeting.

LETTER POSITIONS										
Letter spacings are to start of next letter										
Series/Size	Text Length									
D 2000	24.5									
	s	h	e	l	b	y				
	7.2	5	4.4	4.4	2.2	4.1	4.5	22.2		

SIGN DESIGNS

TIP NO. R-2707AA	SHEET NO. SIGN-4F
APPROVED: <i>[Signature]</i>	
DATE: 10-30-2012	
SEAL	
	

401 QUANTITY REQ'D 1

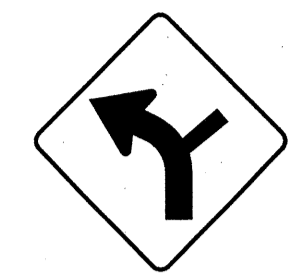

36" X 36"
W1-10 (L)

ONE "U" POST PER SIGN

406 QUANTITY REQ'D 17

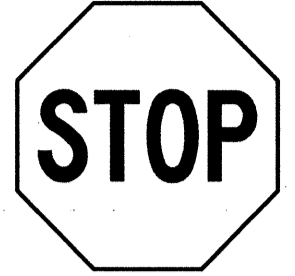

36" X 36"
R1-1

ONE "U" POST PER SIGN
MOUNT BACK-TO-BACK WITH SIGN 407
IN 3 INSTALLATIONS

411 QUANTITY REQ'D 6

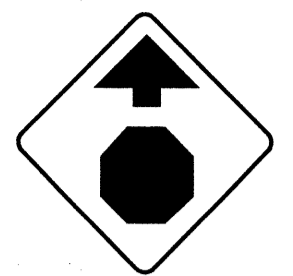

36" X 36"
W3-1

ONE "U" POST PER SIGN

416 QUANTITY REQ'D 1

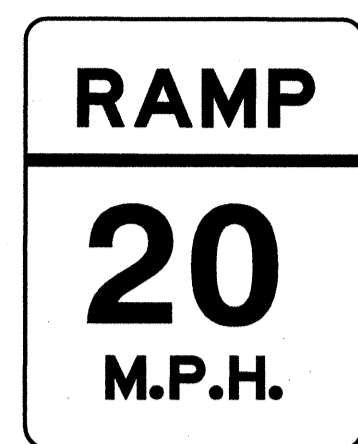

36" X 48"
W13-3

TWO "U" POSTS PER SIGN

421 QUANTITY REQ'D 2

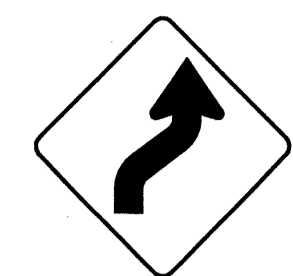

36" X 36"
W1-4R

ONE "U" POST PER SIGN

425 QUANTITY REQ'D 2

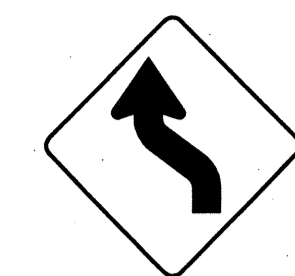

36" X 36"
W1-4L

ONE "U" POST PER SIGN

402 QUANTITY REQ'D 2



36" X 48"
R2-1

TWO "U" POSTS PER SIGN

407 QUANTITY REQ'D 13



24" X 30"
R4-7

ONE "U" POST PER SIGN

412 QUANTITY REQ'D 1



48" X 48"
W19-3

TWO "U" POSTS PER SIGN

417 QUANTITY REQ'D 1

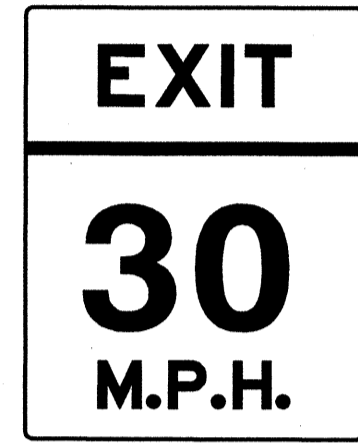

36" X 48"
W13-2

TWO "U" POSTS PER SIGN

422 QUANTITY REQ'D 2



18" X 18"
W13-1P

MOUNT BELOW SIGN 421 IN 2 INSTALLATIONS

426 QUANTITY REQ'D 2



18" X 18"
W13-1P

MOUNT BELOW SIGN 425 IN 2 INSTALLATIONS

403 QUANTITY REQ'D 1

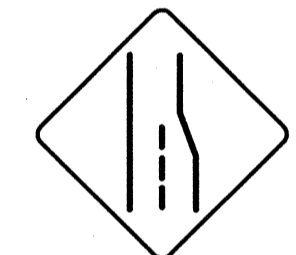

48" X 48"
W4-2L

TWO "U" POSTS PER SIGN

408 QUANTITY REQ'D 13

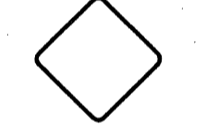

18" X 18"
OM1-3

MOUNT BELOW SIGN 407 IN 13 INSTALLATIONS

413 QUANTITY REQ'D 2

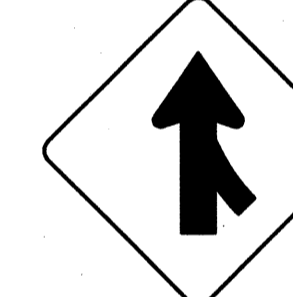

48" X 48"
W4-1 (R)

TWO "U" POSTS PER SIGN

418 QUANTITY REQ'D 1

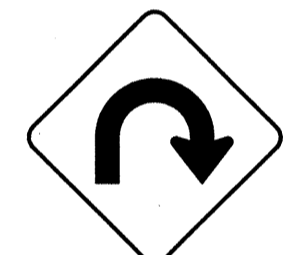

48" X 48"
W1-11R

TWO "U" POSTS PER SIGN

423 QUANTITY REQ'D 1

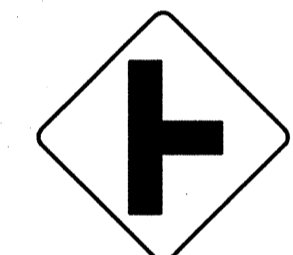

30" X 30"
W2-2 (R)

ONE "U" POST PER SIGN

404 QUANTITY REQ'D 2



18" X 18"
W13-1P

MOUNT BELOW SIGN 401 IN 1 INSTALLATION
MOUNT BELOW SIGN 414 IN 1 INSTALLATION

409 QUANTITY REQ'D 2



54" X 18"
R6-1 (R)

TWO "U" POSTS PER SIGN

414 QUANTITY REQ'D 1

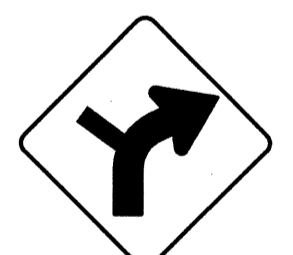

36" X 36"
W1-10 (R)

ONE "U" POST PER SIGN

419 QUANTITY REQ'D 1



30" X 30"
W13-1P

MOUNT BELOW SIGN 418 IN 1 INSTALLATION

424 QUANTITY REQ'D 4



24" X 30"
W1-8 (R)

ONE "U" POST PER SIGN

405 QUANTITY REQ'D 4



36" X 24"
R5-1a

ONE "U" POST PER SIGN

410 QUANTITY REQ'D 3



36" X 36"
R5-1

MOUNT ON BACK OF SIGN 406 IN 3 INSTALLATIONS

415 QUANTITY REQ'D 6



36" X 36"
W14-2







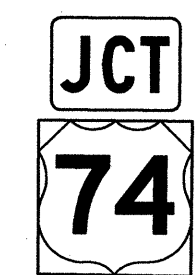
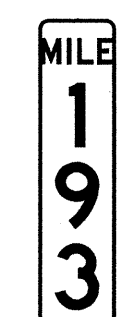

ONE "U" POST PER SIGN

420 QUANTITY REQ'D 2

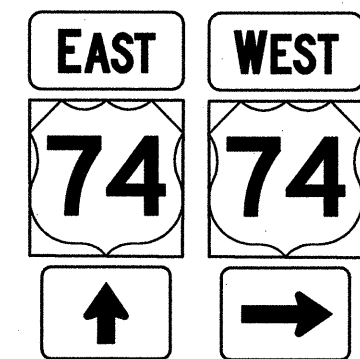

30" X 36"
R2-1

ONE "U" POST PER SIGN

<p>(501) (506)</p>  <p>1 - 36" X 18" 1 - 36" X 36"</p> <p>TWO "U" POSTS PER SIGN</p>	<p>(507) (508)</p>  <p>1 - 21" X 15" 1 - 24" X 24"</p> <p>ONE "U" POST PER SIGN</p>			 <p>12" X 48"</p> <p>ONE "U" POST PER SIGN</p>	
<p>(502)</p>  <p>2 - 24" X 12" 2 - 24" X 24" 2 - 21" X 15"</p> <p>TWO "U" POSTS PER SIGN</p>	<p>(509)</p>  <p>1 - 36" X 18" 1 - 36" X 36"</p> <p>TWO "U" POSTS PER SIGN</p>			 <p>12" X 48"</p> <p>ONE "U" POST PER SIGN</p>	
<p>(503)</p>  <p>1 - 24" X 12" 1 - 24" X 24" 1 - 21" X 15"</p> <p>MOUNTED BELOW SIGN 306</p>	<p>(510)</p>  <p>1 - 36" X 18" 1 - 36" X 36"</p> <p>TWO "U" POSTS PER SIGN</p>				
<p>(504)</p>  <p>2 - 24" X 12" 2 - 24" X 24" 2 - 21" X 15"</p> <p>TWO "U" POSTS PER SIGN</p>					
<p>(505)</p>  <p>1 - 24" X 12" 1 - 24" X 24" 1 - 21" X 15"</p> <p>MOUNTED BELOW SIGN 310</p>					

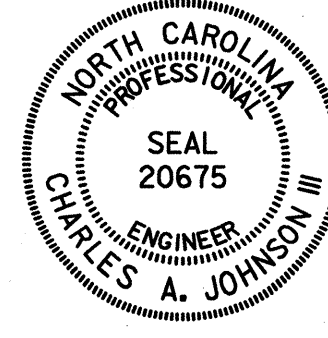
TIP NO. R-2707AA	SHEET NO. SIGN-4G
APPROVED: <i>[Signature]</i>	
DATE: 8-29-2012	
SEAL	
	

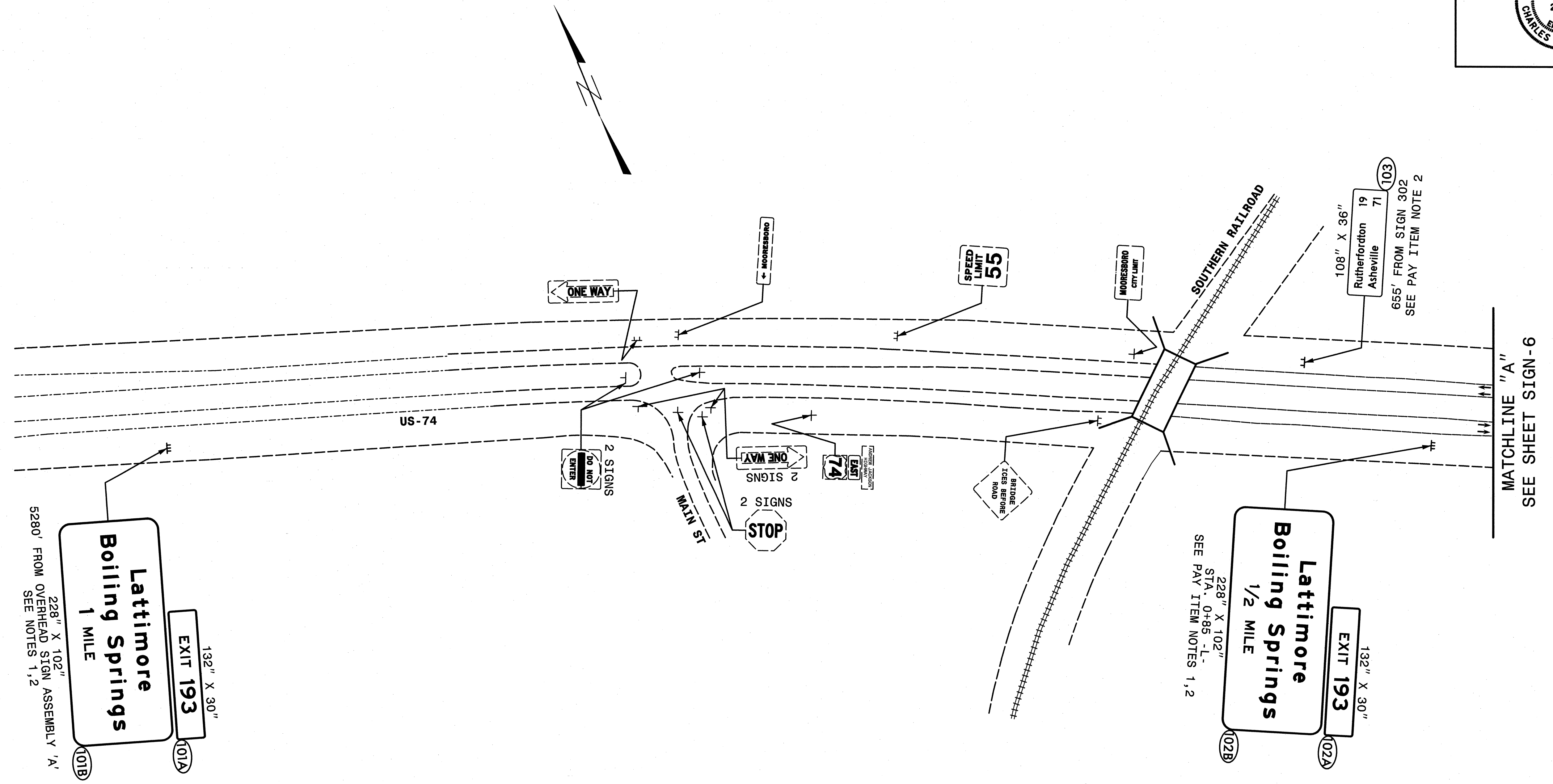

NOTES:
 REMOVE AND DISPOSE OF EXISTING SIGNS WITHIN PROJECT LIMITS UNLESS OTHERWISE NOTED.
 ALL PROPOSED SIGNS SEE NOTE 3 UNLESS OTHERWISE NOTED.

HNTB HNTB NORTH CAROLINA, P.C.
 343 E. Six Forks Road, Suite 200
 Raleigh, North Carolina 27609
 NC License No: C-1554

PROPOSED SIGNS
5280' AHEAD OF PROJECT

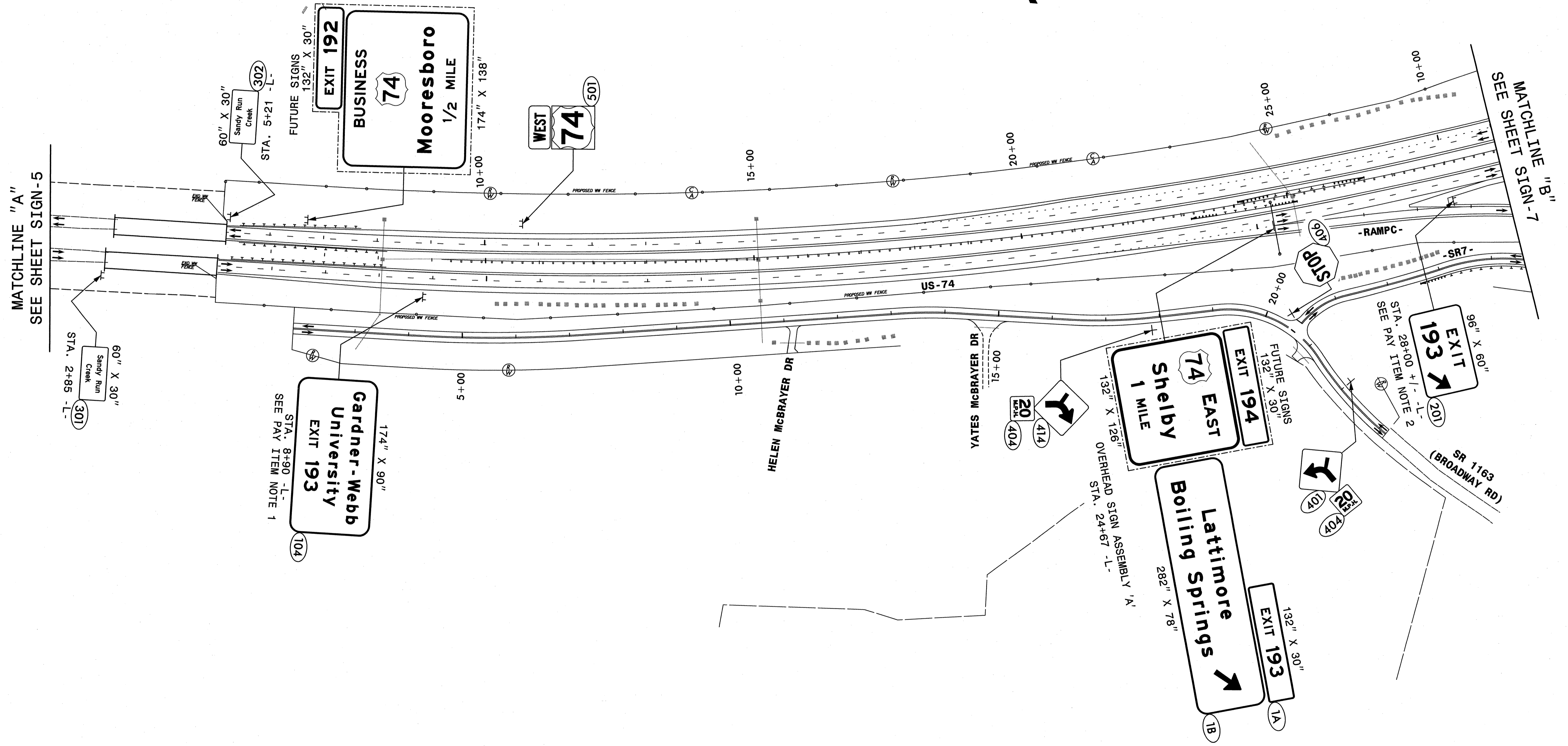

NOTES:
 REMOVE AND DISPOSE OF EXISTING SIGNS WITHIN PROJECT LIMITS UNLESS OTHERWISE NOTED.
 ALL PROPOSED SIGNS SEE NOTE 3 UNLESS OTHERWISE NOTED.

HNTB HNTB NORTH CAROLINA, P.C.
 343 E. Six Forks Road, Suite 200
 Raleigh, North Carolina 27609
 NC License No: C-1554

PROPOSED SIGNS
 300' FROM STA. 5+00 TO 29+00

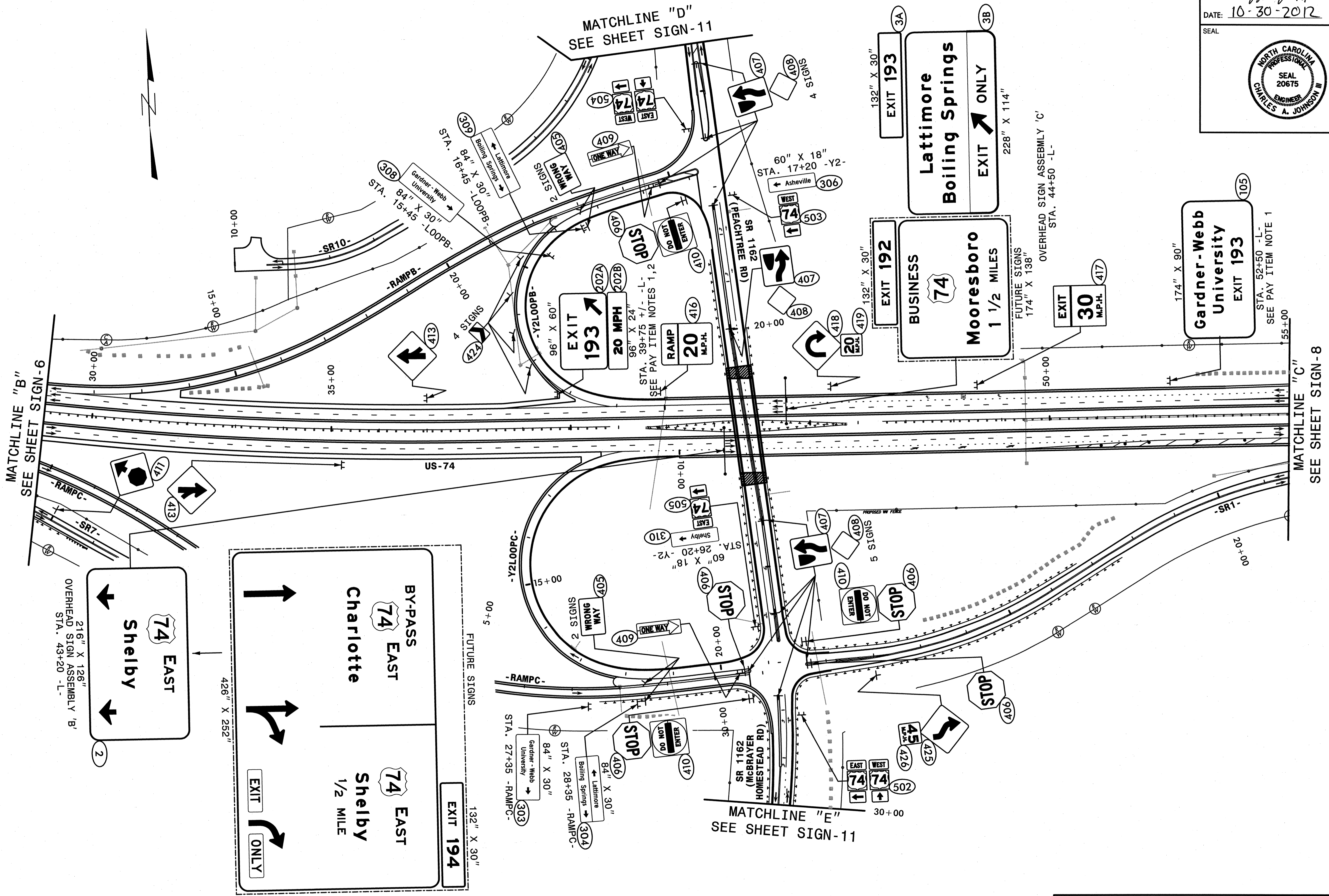

NOTES:
 REMOVE AND DISPOSE OF EXISTING SIGNS WITHIN PROJECT LIMITS UNLESS OTHERWISE NOTED.
 ALL PROPOSED SIGNS SEE NOTE 3 UNLESS OTHERWISE NOTED.

HNTB HNTB NORTH CAROLINA, P.C.
 343 E. Six Forks Road, Suite 200
 Raleigh, North Carolina 27609
 NC License No: C-1554

PROPOSED SIGNS
STA. 29+00 TO 55+00

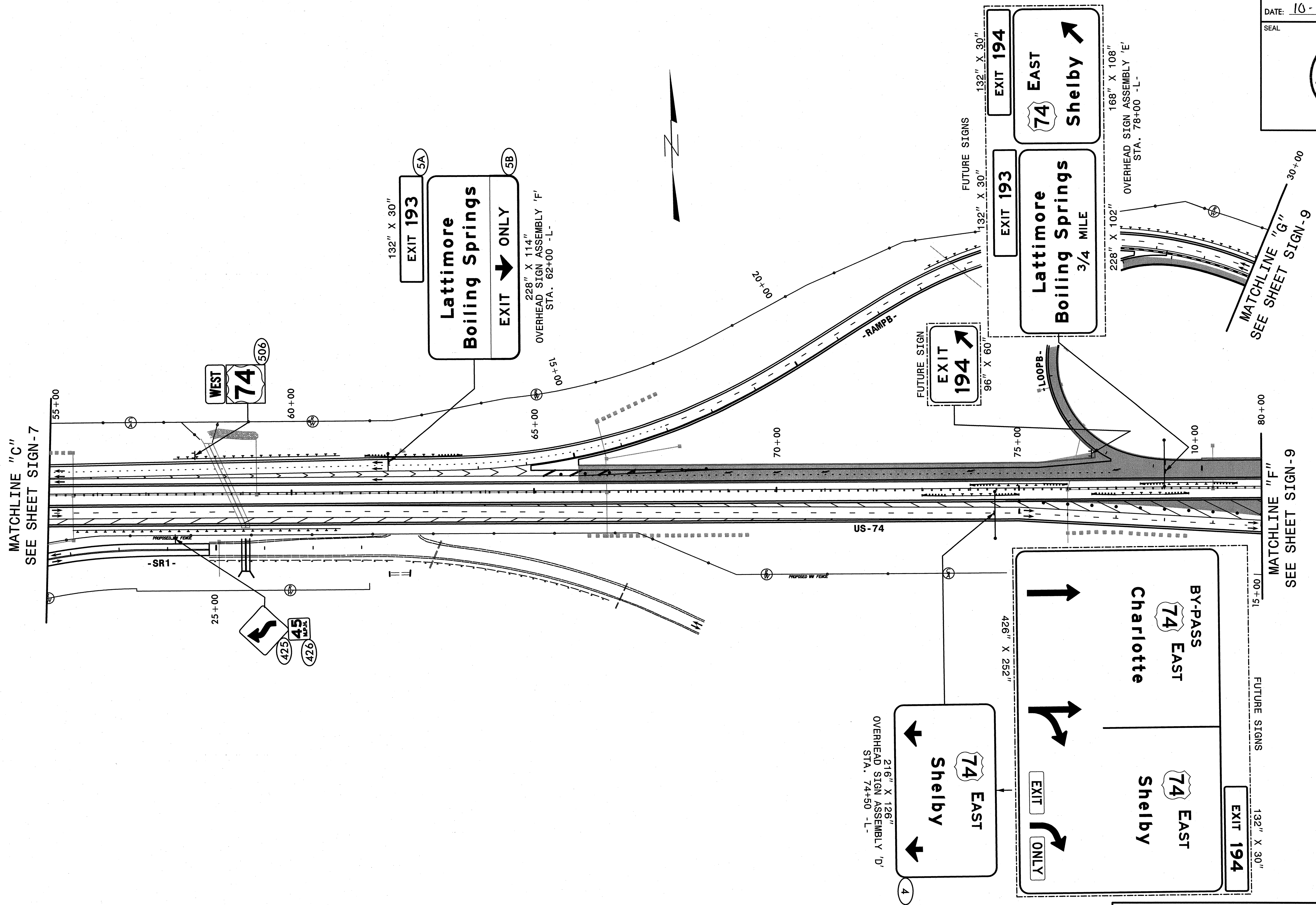

NOTES:
 REMOVE AND DISPOSE OF EXISTING SIGNS WITHIN PROJECT LIMITS UNLESS OTHERWISE NOTED.
 ALL PROPOSED SIGNS SEE NOTE 3 UNLESS OTHERWISE NOTED.

PROPOSED SIGNS
STA. 55+00 TO 80+00 -L-

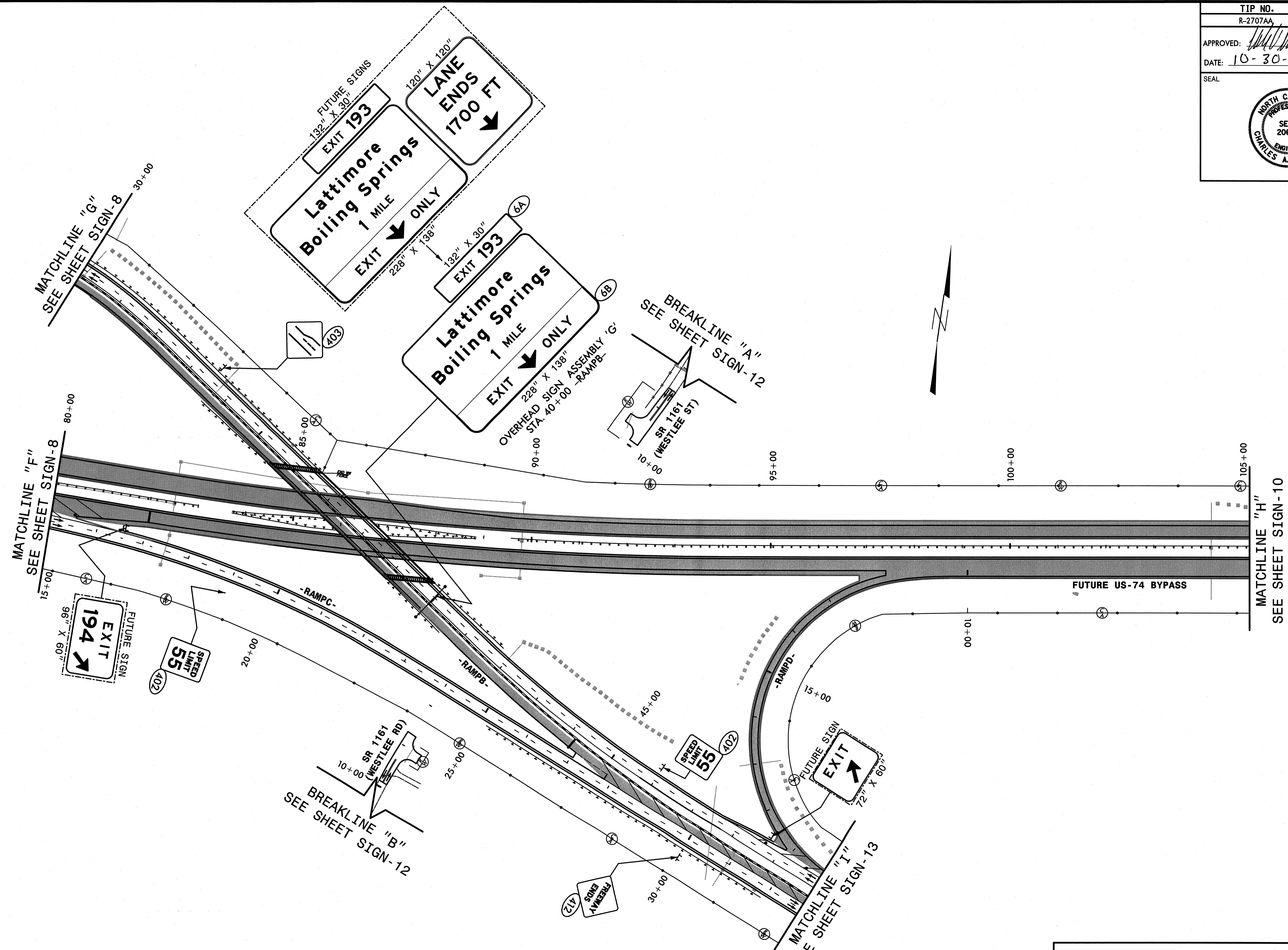

NOTES:
 REMOVE AND DISPOSE OF EXISTING SIGNS WITHIN PROJECT LIMITS UNLESS OTHERWISE NOTED.
 ALL PROPOSED SIGNS SEE NOTE 3 UNLESS OTHERWISE NOTED.

HNTB HNTB NORTH CAROLINA, P.C.
 343 E. Six Forks Road, Suite 200
 Raleigh, North Carolina 27609
 NC License No: C-1554

PROPOSED SIGNS
STA. 80+00 TO 105+00 -L-

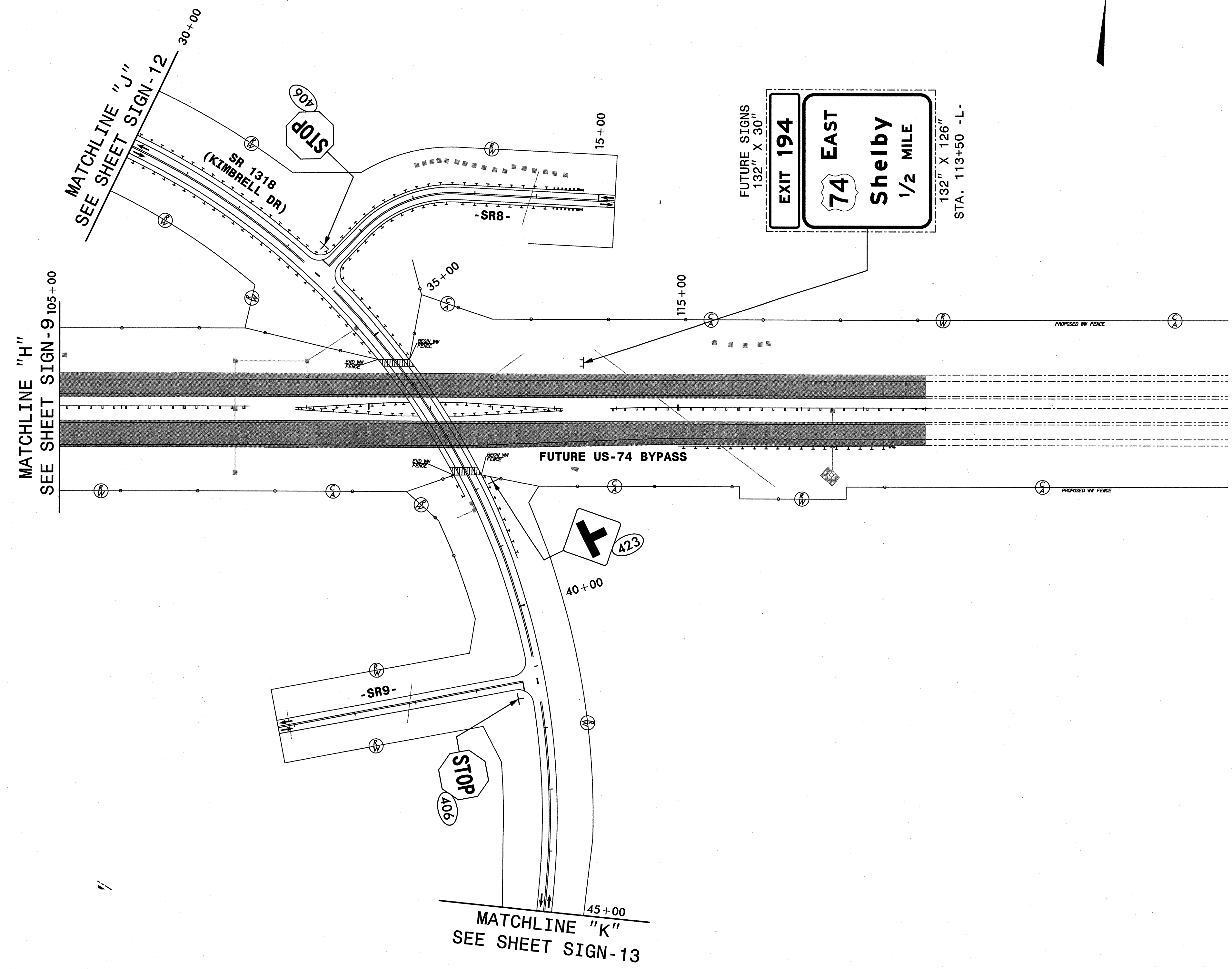
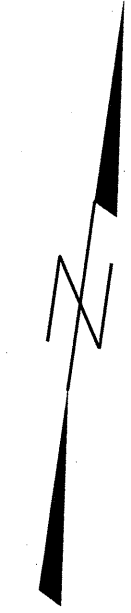

NOTES:
 REMOVE AND DISPOSE OF EXISTING SIGNS WITHIN PROJECT LIMITS UNLESS OTHERWISE NOTED.
 ALL PROPOSED SIGNS SEE NOTE 3 UNLESS OTHERWISE NOTED.

HNTB HNTB NORTH CAROLINA, P.C.
 343 E. Six Forks Road, Suite 200
 Raleigh, North Carolina 27609
 NC License No: C-1554

PROPOSED SIGNS
STA. 105+00 TO 119+00 -L-

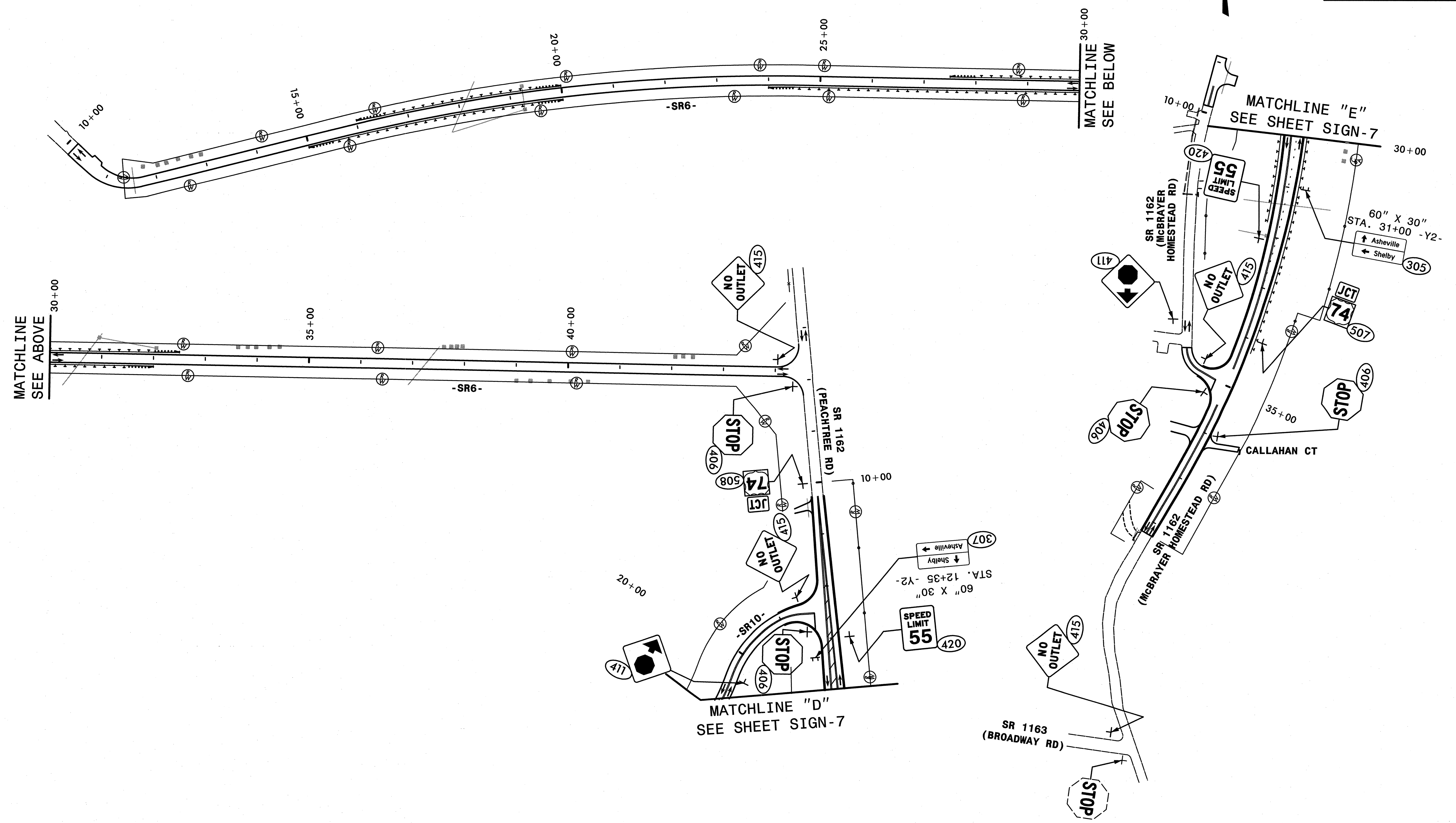

NOTES:
 REMOVE AND DISPOSE OF EXISTING SIGNS WITHIN PROJECT LIMITS UNLESS OTHERWISE NOTED.
 ALL PROPOSED SIGNS SEE NOTE 3 UNLESS OTHERWISE NOTED.

HNTB HNTB NORTH CAROLINA, P.C.
 343 E. Six Forks Road, Suite 200
 Raleigh, North Carolina 27609
 NC License No: C-1554

PROPOSED SIGNS
 STA. 10+00 TO 44+00 -SR6-
 STA. 7+00 TO 14+00 AND
 30+00 TO 38+00 -Y2-

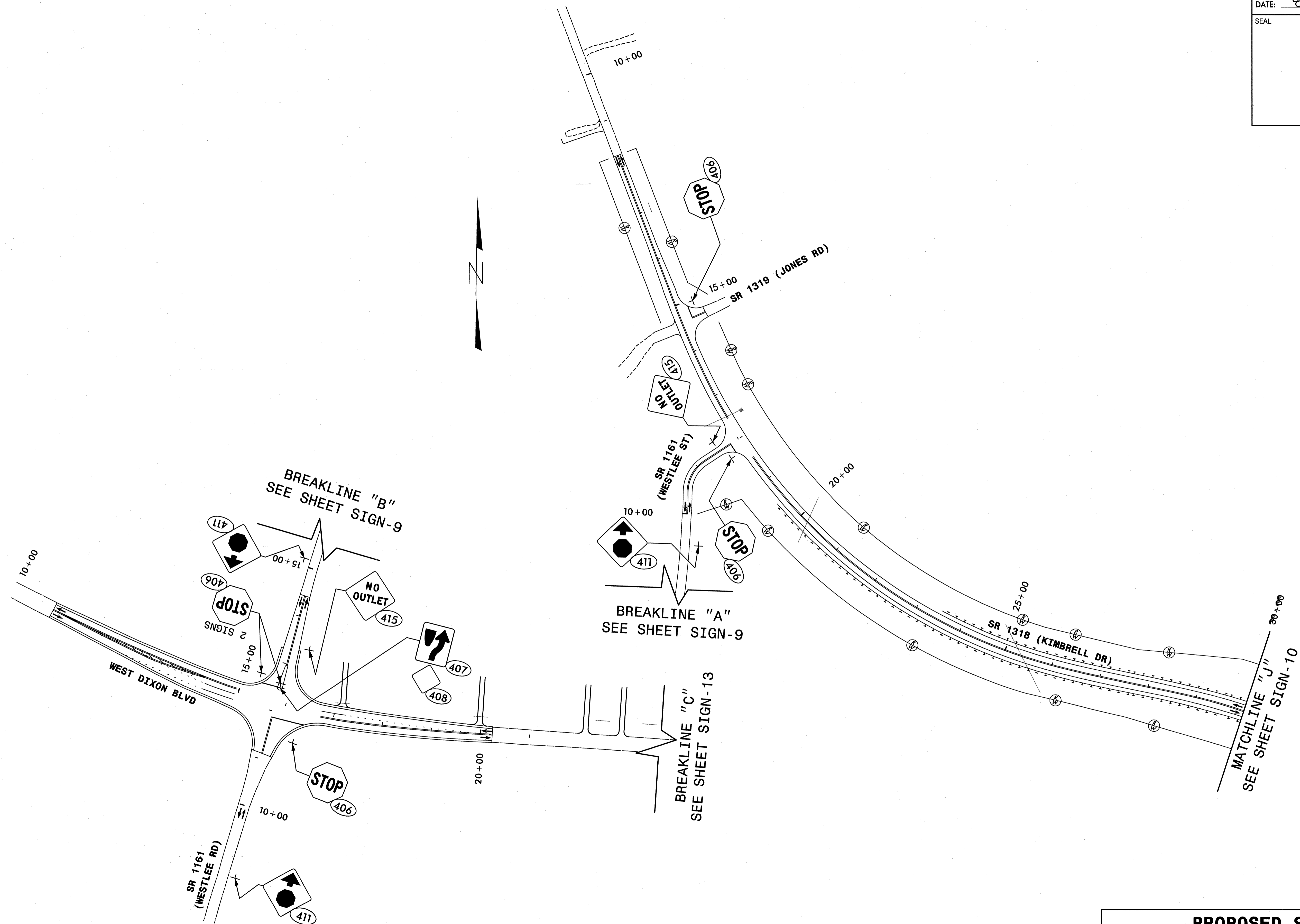

NOTES:
 REMOVE AND DISPOSE OF EXISTING SIGNS WITHIN PROJECT LIMITS UNLESS OTHERWISE NOTED.
 ALL PROPOSED SIGNS SEE NOTE 3 UNLESS OTHERWISE NOTED.

HNTB HNTB NORTH CAROLINA, P.C.
 343 E. Six Forks Road, Suite 200
 Raleigh, North Carolina 27609
 NC License No: C-1554

PROPOSED SIGNS
 -Y4- SR 1318 (KIMBRELL RD)
 -Y7- SR 1161 (WEST LEE ST)

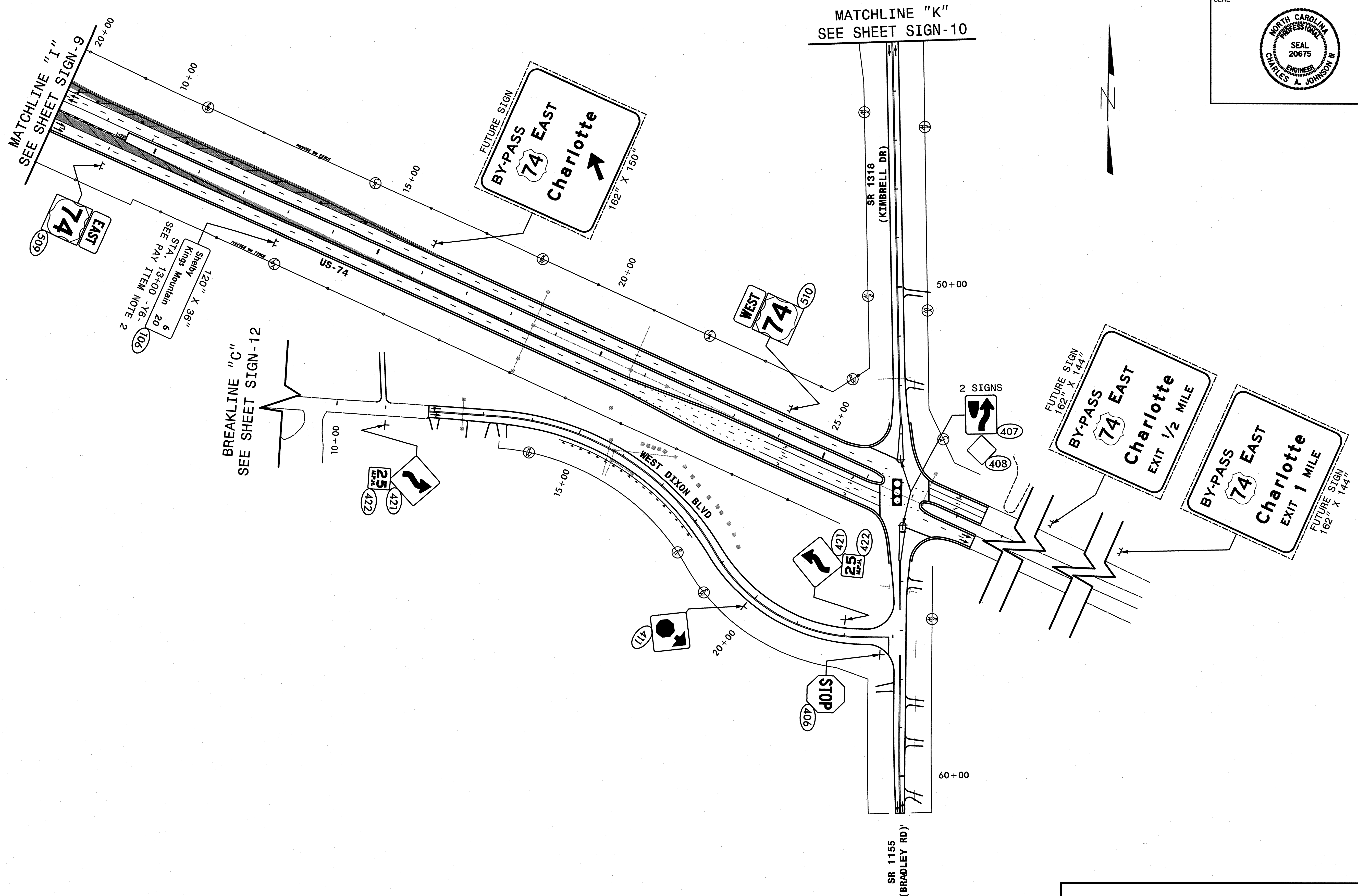

NOTES:
 REMOVE AND DISPOSE OF EXISTING SIGNS WITHIN PROJECT LIMITS UNLESS OTHERWISE NOTED.
 ALL PROPOSED SIGNS SEE NOTE 3 UNLESS OTHERWISE NOTED.

HNTB HNTB NORTH CAROLINA, P.C.
 343 E. Six Forks Road, Suite 200
 Raleigh, North Carolina 27609
 NC License No: C-1554

PROPOSED SIGNS
STA. 8+00 TO 29+00 -Y6-