

STATE OF NORTH CAROLINA
DIVISION OF HIGHWAYS

PERSON COUNTY

LOCATION: US 501 FROM NC 49 IN ROXBORO
TO SOUTH OF SR 1602

TYPE OF WORK: SIGNALS

Project: R-2241A

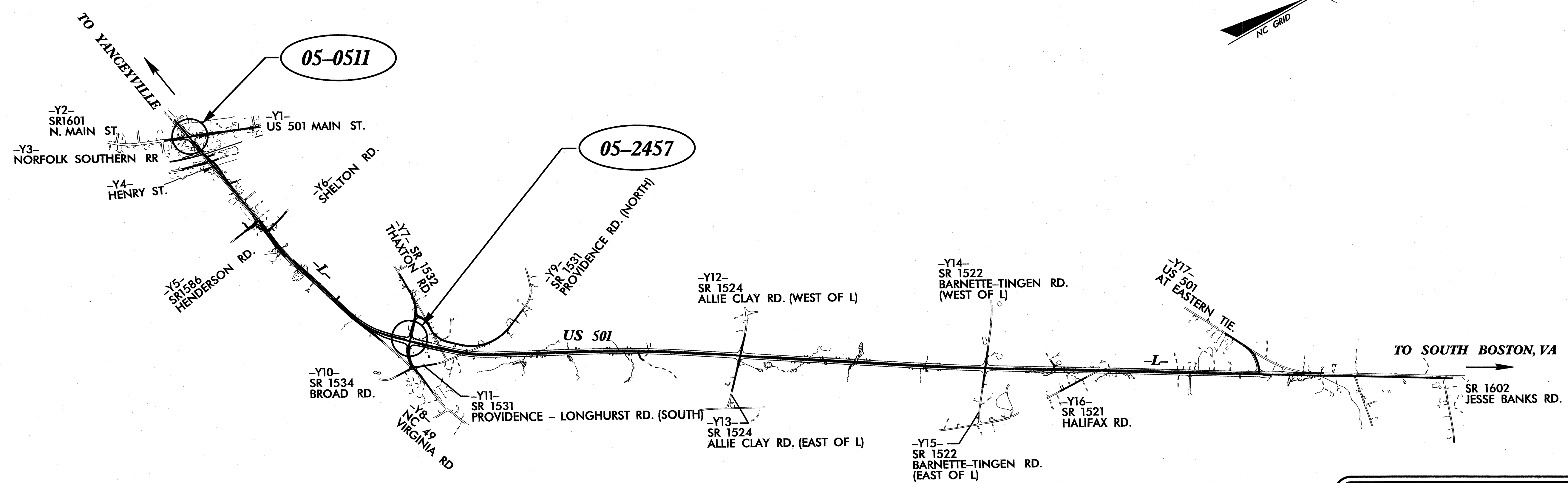
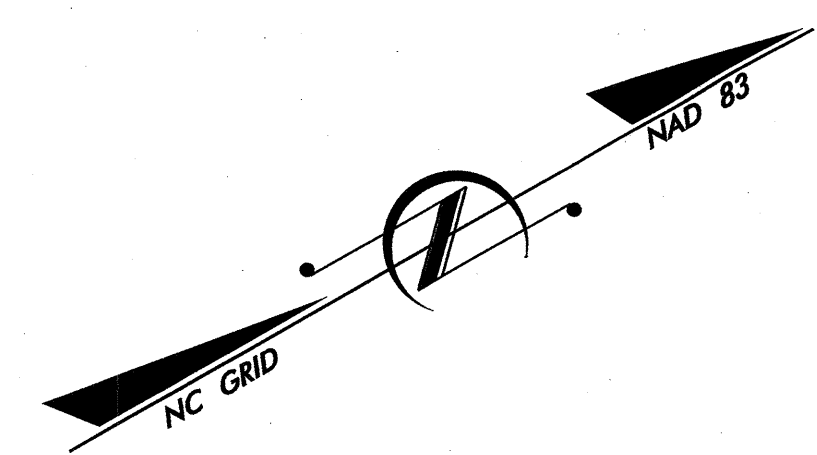
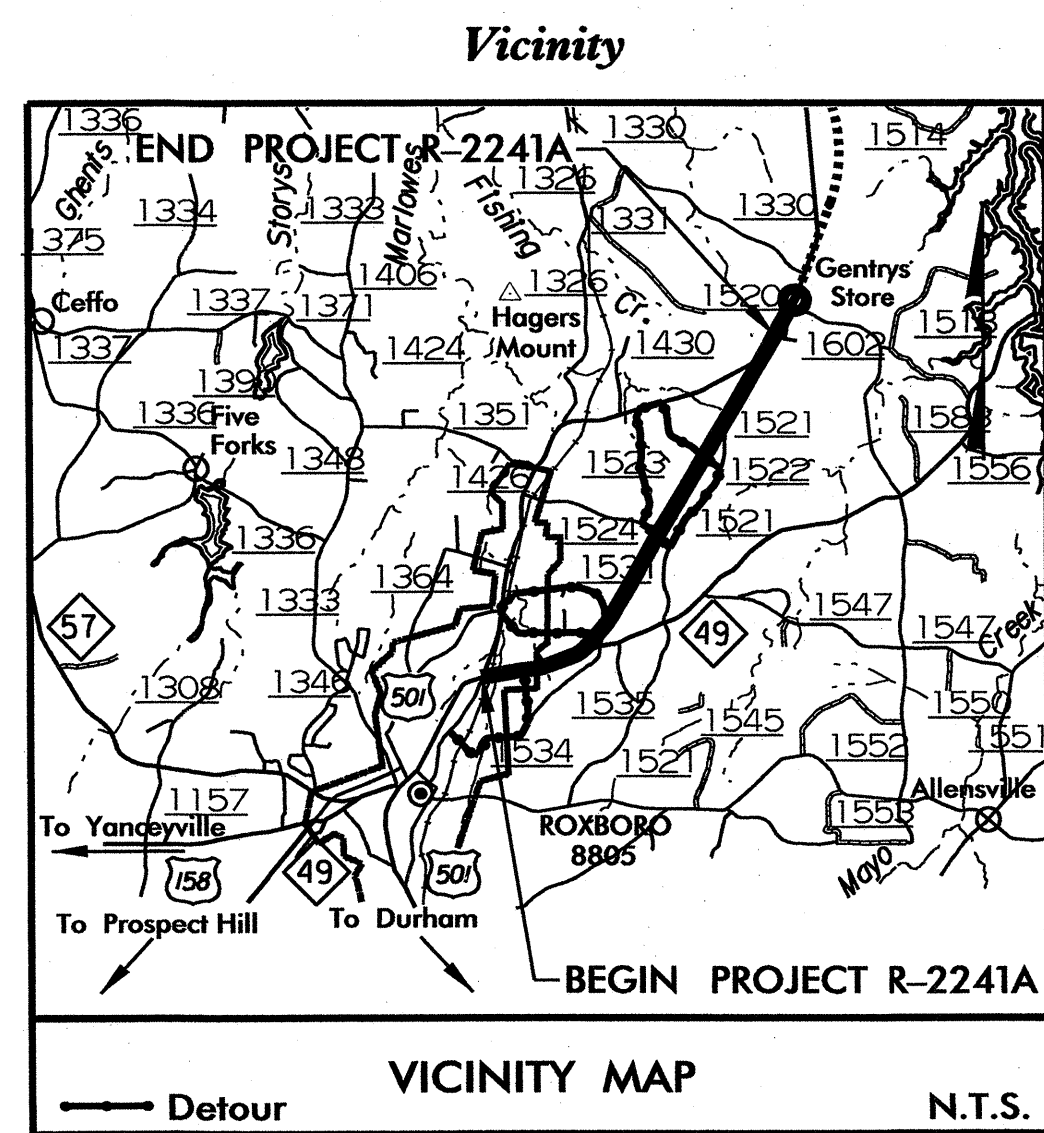

CONTRACT: C202960

29-NOV-2012 16:06 P:\TTP\Projects\R2241A\Traffic\Signals\Design\TitleSheet\R2241A.s.dgn

Refer to "Roadway Standard Drawings NCDOT" dated Jul, 2006 and "Standard Specifications for Roads and Structures" dated Jul, 2006.

Index of Plans		Location/Description
Sheet #	Reference #	
Sig. 1		Title Sheet
Sig. 2-10	05-0511	US 501/NC 49 (N. Madison Blvd./Virgilina Rd.) at US 501/SR 1601 (N. Main St.)
Sig. 11-21	05-2457	US 501 at NC 49 Virgilina Rd./SR 1532 (Thaxton Rd.)
Sig. 22-24	N/A	Inductive Detection Loop Details
Sig. 25-30	N/A	Standard Metal Pole Drawings

INTELLIGENT TRANSPORTATION AND SIGNALS UNIT

Contacts:

Robert J. Ziemba, PE - Central Region Signals Project Engineer
John T. Rowe, Jr., PE - Signal Equipment Design Engineer

Prepared In the Office of:
DIVISION OF HIGHWAYS
TRANSPORTATION MOBILITY AND SAFETY DIVISION

750 N. Greenfield Parkway, Garner, NC 27529

PHASING DIAGRAM

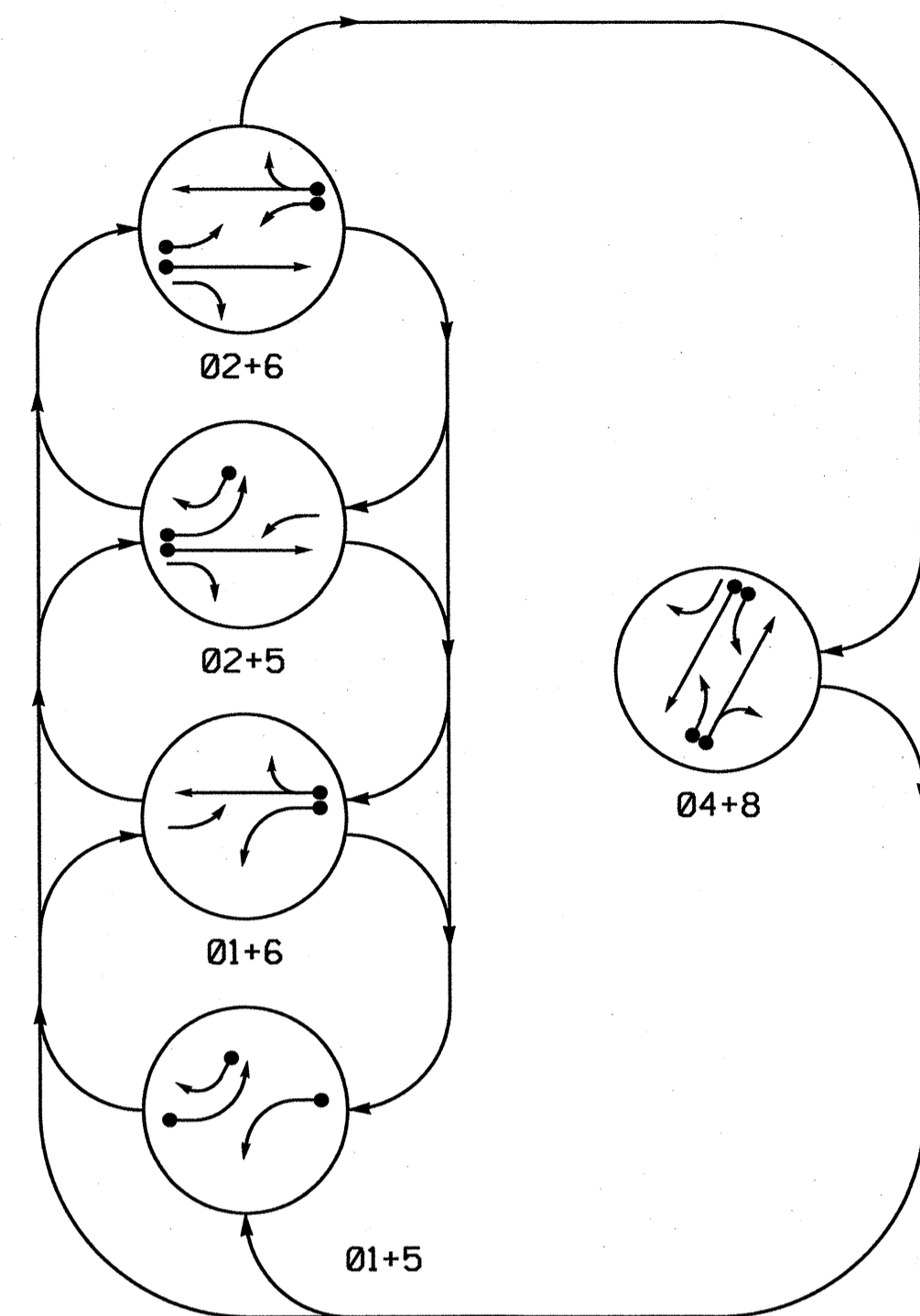

PHASING DIAGRAM DETECTION LEGEND

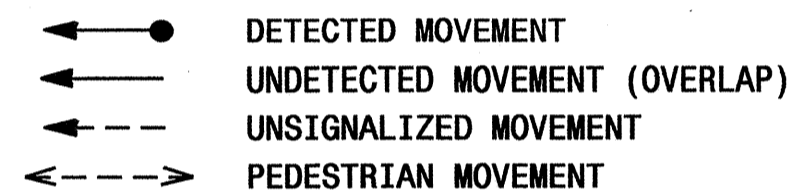

TABLE OF OPERATION

SIGNAL FACE	PHASE				
	01+5	01+6	02+5	02+6	FLASH
11	←	←	←	←	←
21, 22	R	R	G	G	R
41	R	R	R	R	R
42	R	R	R	R	G
43	R	R	R	R	G
51	←	←	←	←	←
61, 62	R	G	R	G	R
81	R	R	R	R	R
82, 83	R	R	R	R	G

F = Flashing Yellow Arrow

SIGNAL FACE I.D.

All Heads L.E.D.

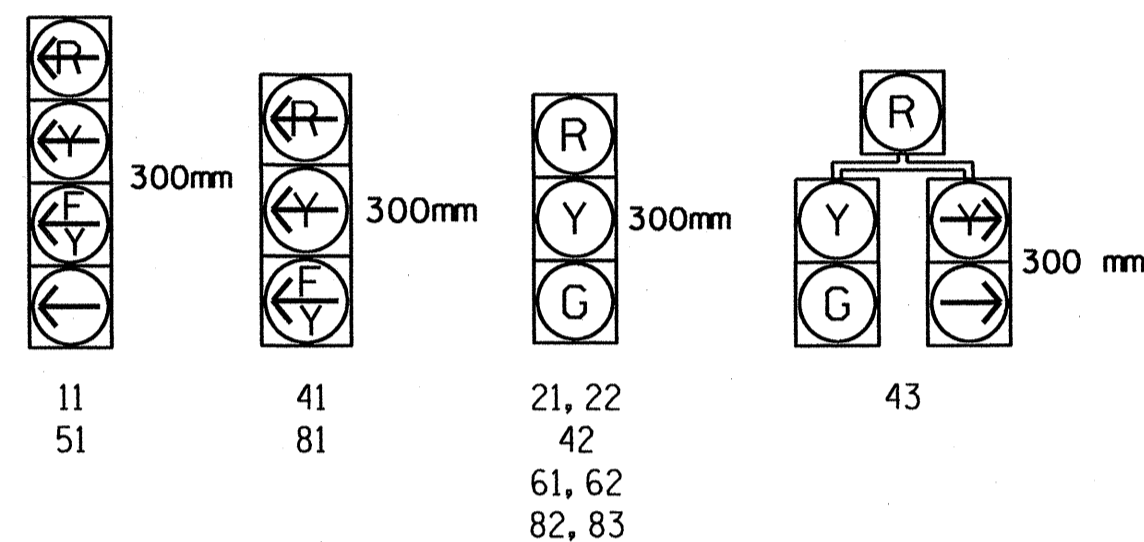

STANDARD SIGNAL FACE CLEARANCES FOR FLASHING LEFT TURN SIGNAL

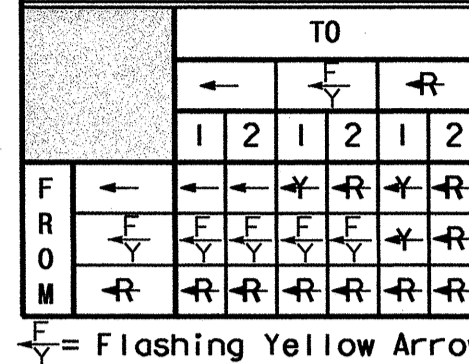

OASIS 2070L LOOP & DETECTOR INSTALLATION

LOOP	SIZE (M)	TURNS	DISTANCE FROM STOPBAR (M)	NEW LOOP	DETECTOR PROGRAMMING						
					PHASE	CALLING	EXTENSION	FULL TIME DELAY	SYSTEM LOOP	STRETCH TIME	DELAY TIME
1A	1.8X12	2-4-2	0	Y	1	Y	Y	-	-	15	Y
2A	1.8X1.8	4	21	Y	2	Y	Y	-	-	-	Y
4A	1.8X12	2-4-2	0	Y	4	Y	Y	-	-	3	Y
4B	1.8X12	2-4-2	0	Y	4	Y	Y	-	-	-	Y
5A	1.8X12	2-4-2	0	Y	5	Y	Y	-	-	15	Y
5B	1.8X12	2-4-2	0	Y	2	Y	Y	-	-	-	Y
6A	1.8X1.8	4	21	Y	6	Y	Y	-	-	-	Y
8A	1.8X12	2-4-2	0	Y	8	Y	Y	-	-	3	Y
8B	1.8X12	2-4-2	0	Y	8	Y	Y	-	-	10	Y

5 Phase Fully Actuated (Isolated)

NOTES

- Refer to "Roadway Standard Drawings NCDOT" dated July 2006 and "Standard Specifications for Roads and Structures" dated July 2006.
- Do not program signal for late night flashing operation unless otherwise directed by the Engineer.
- Phase 1 and/or phase 5 may be lagged.
- Set all detector units to presence mode.
- Locate new cabinet so as not to obstruct sight distance of vehicles turning right on red.
- Pavement markings are existing.

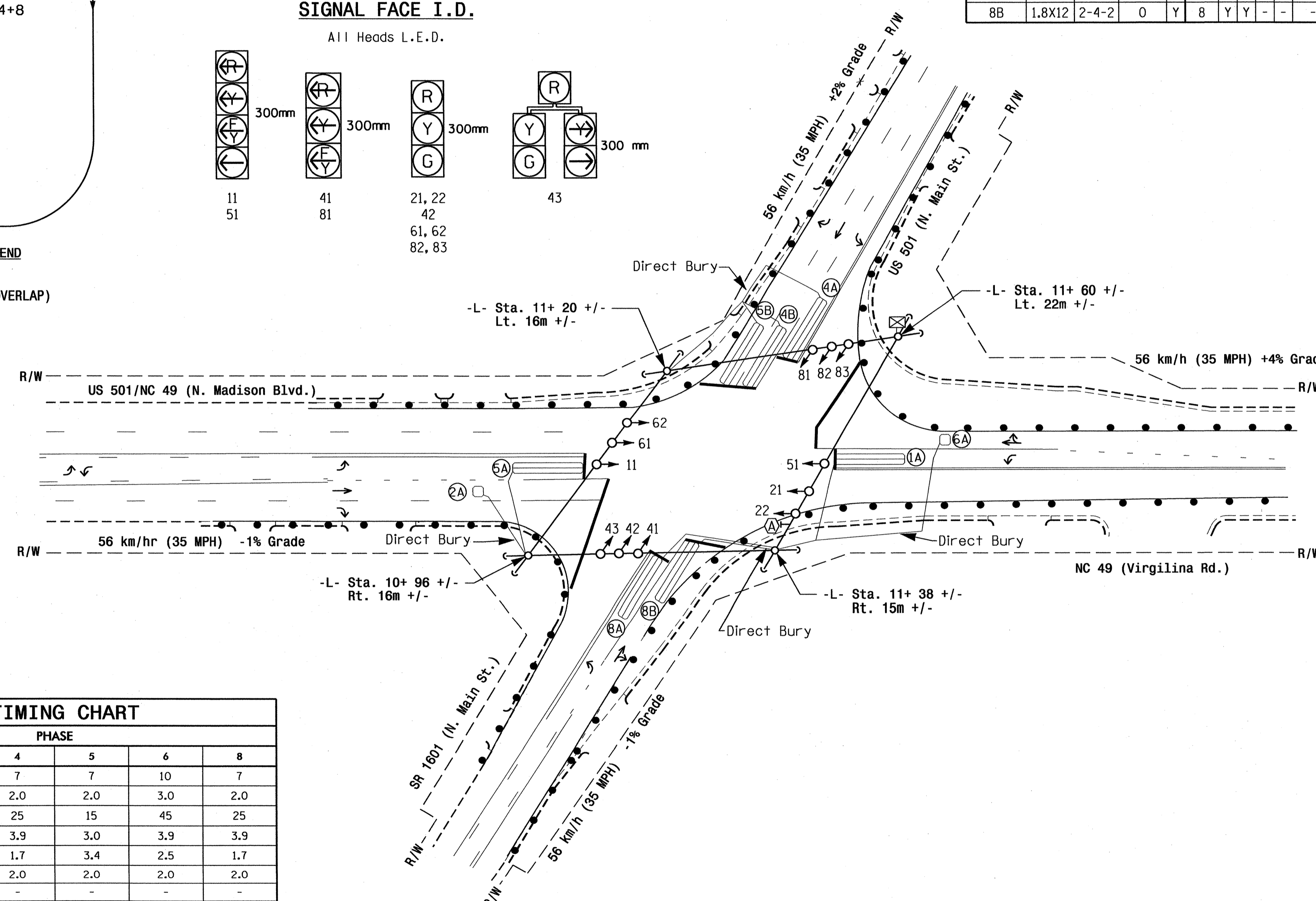

OASIS 2070L TIMING CHART

FEATURE	PHASE					
	1	2	4	5	6	8
Min Green 1*	7	10	7	7	10	7
Extension 1*	2.0	3.0	2.0	2.0	3.0	2.0
Max Green 1*	15	45	25	15	45	25
Yellow Clearance	3.0	3.9	3.9	3.0	3.9	3.9
Red Clearance	3.3	2.5	1.7	3.4	2.5	1.7
Red Revert	2.0	2.0	2.0	2.0	2.0	2.0
Walk 1*	-	-	-	-	-	-
Don't Walk 1	-	-	-	-	-	-
Seconds Per Actuation*	-	-	-	-	-	-
Max Variable Initial*	-	-	-	-	-	-
Time Before Reduction*	-	-	-	-	-	-
Time To Reduce*	-	-	-	-	-	-
Minimum Gap	-	-	-	-	-	-
Recall Mode	-	MIN RECALL	-	-	MIN RECALL	-
Vehicle Call Memory	-	YELLOW	-	-	YELLOW	-
Dual Entry	-	-	ON	-	-	ON
Simultaneous Gap	ON	ON	ON	ON	ON	ON

* These values may be field adjusted. Do not adjust Min Green and Extension times for phases 2 and 6 lower than what is shown. Min Green for all other phases should not be lower than 4 seconds.

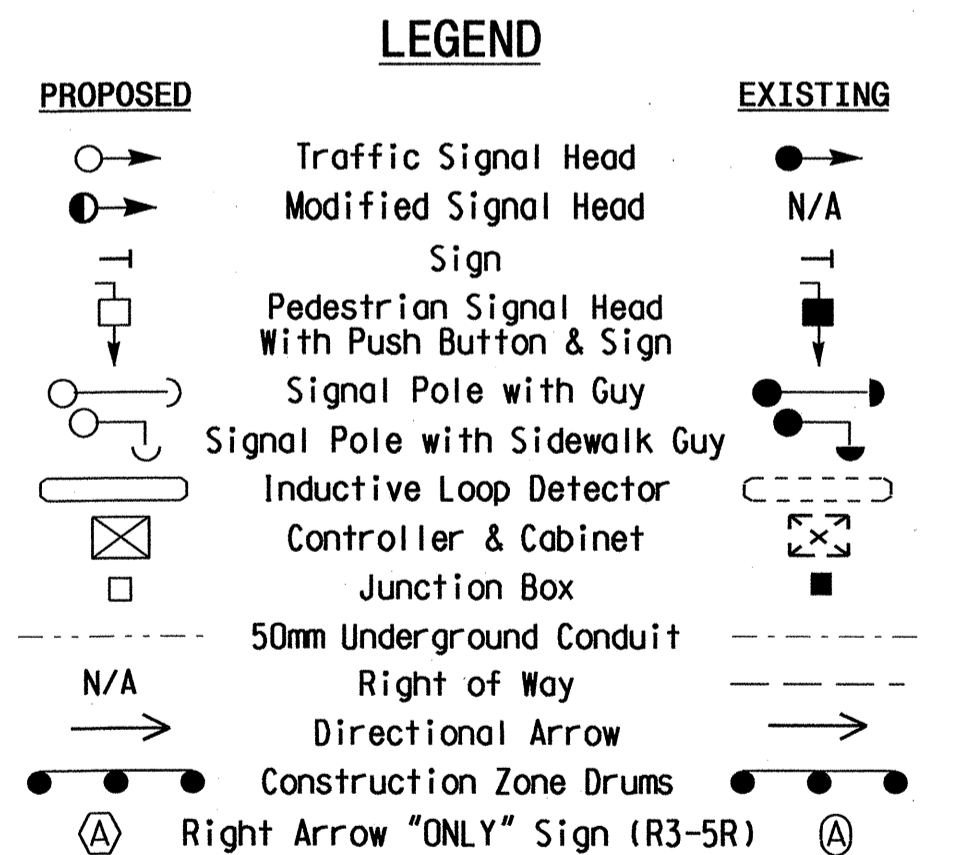

Signal Upgrade - Temporary Design 1 (TMP Phase I)

Prepared in the Offices of:
 Transportation Mobility and Safety Division
 NORTH CAROLINA DEPARTMENT OF TRANSPORTATION
 Signal Design Section
 750 N. Greenfield Pkwy, Garner, NC 27529

US 501/NC 49 (N. Madison Blvd./Virgilina Rd.) at SR 1601 (N. Main St.)
 Division 5 Person County Roxboro
 PREPARED BY: R. Hough REVIEWED BY:
 SCALE: 1:500

SEAL
 ROBERT J. ZIEGLER
 ENGINEER
 2/3/12
 SIGNATURE DATE
 SIG. INVENTORY NO. 05-0511T1

11/11/2012 16:14:45
 P:\11\TTP\050511T1\050511T1_01.dgn, 2012/03/11, dgn
 P:\11\TTP\050511T1\050511T1_01.dgn, 2012/03/11, dgn
 P:\11\TTP\050511T1\050511T1_01.dgn, 2012/03/11, dgn

EDI MODEL 2018ECL-NC CONFLICT MONITOR

PROGRAMMING DETAIL

(remove jumpers and set switches as shown)

REMOVE DIODE JUMPERS 1-5, 1-6, 1-9, 1-11, 2-5, 2-6, 2-9, 2-11, 4-8, 4-10, 4-12, 5-9, 5-11, 6-9, 6-11, 8-10, 8-12, 9-11, and 10-12.

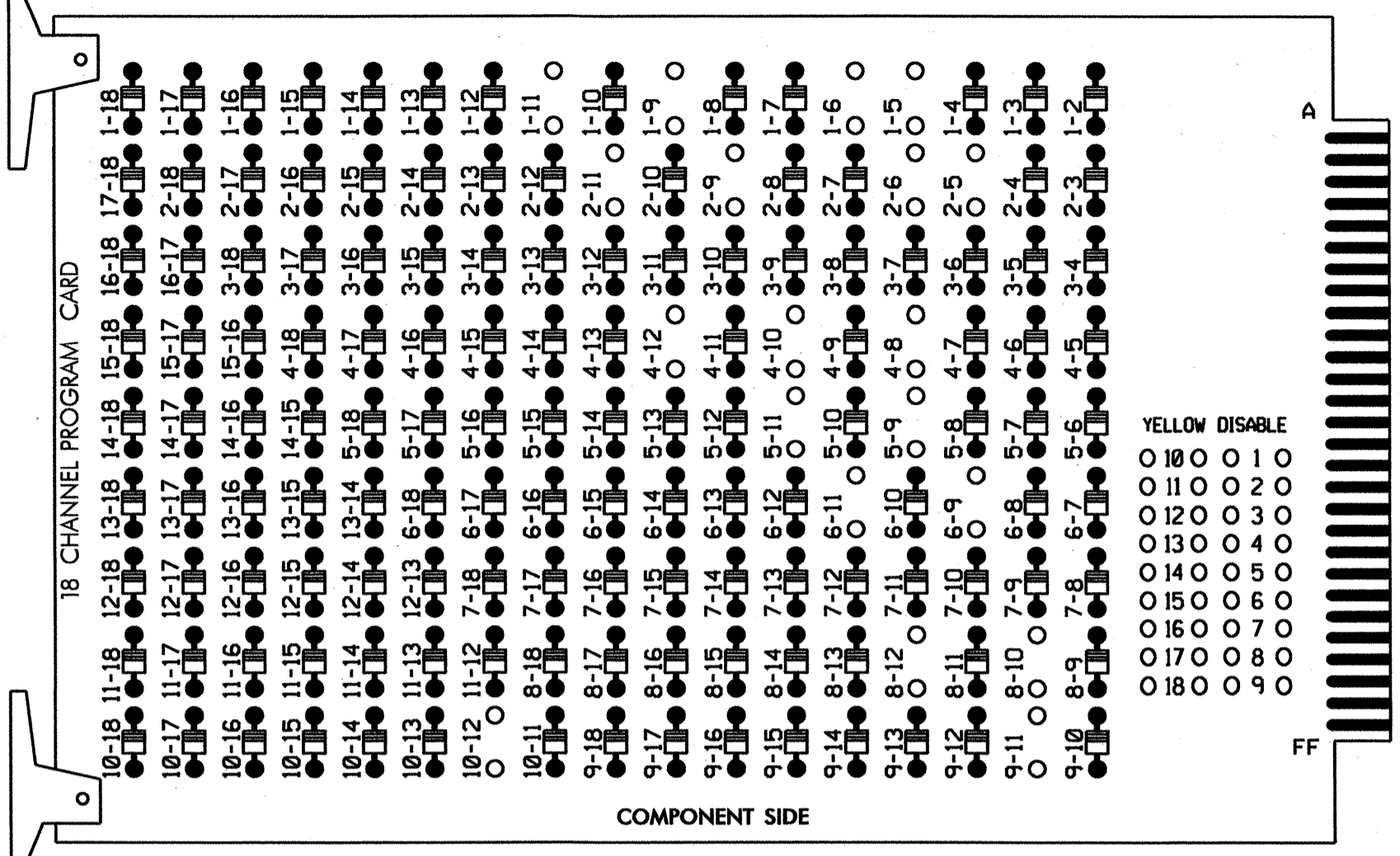

REMOVE JUMPERS AS SHOWN

NOTES:

- Card is provided with all diode jumpers in place. Removal of any jumper allows its channels to run concurrently.
- Ensure jumpers SEL2-SEL5 and SEL9 are present on the monitor board.
- Ensure that Red Enable is active at all times during normal operation.
- Connect serial cable from conflict monitor to comm. port 1 of 2070 controller. Ensure conflict monitor communicates with 2070.

NOTES

- To prevent "flash-conflict" problems, insert red flash program blocks for all unused vehicle load switches in the output file. The installer shall verify that signal heads flash in accordance with the Signal Plans.
- Program phases 4 and 8 for Dual Entry.
- Enable Simultaneous Gap-Out for all phases.
- Program phases 2 and 6 for Start Up In Green.
- Program phases 2 and 6 for Yellow Flash, and overlaps 1 and 2 as Wag Overlaps.

EQUIPMENT INFORMATION

CONTROLLER.....2070L
 CABINET.....332 W/ AUX
 SOFTWARE.....ECONOLITE OASIS
 CABINET MOUNT.....BASE
 OUTPUT FILE POSITIONS...18 WITH AUX. OUTPUT FILE
 LOAD SWITCHES USED.....S1,S2,S5,S7,S8,S11,AUX S1,
 AUX S2,AUX S4,AUX S5
 PHASES USED.....1,2,4,5,6,8
 OVERLAP "A".....1+2
 OVERLAP "B".....8
 OVERLAP "C".....5+6
 OVERLAP "D".....4

SIGNAL HEAD HOOK-UP CHART

LOAD SWITCH NO.	S1	S2	S3	S4	S5	S6	S7	S8	S9	S10	S11	S12	AUX S1	AUX S2	AUX S3	AUX S4	AUX S5	AUX S6
CMU CHANNEL NO.	1	2	13	3	4	14	5	6	15	7	8	16	9	10	17	11	12	18
PHASE	1	2	2 PED	3	4	4 PED	5	6	6 PED	7	8	8 PED	OLA	OLB	SPARE	OLC	OLD	SPARE
SIGNAL HEAD NO.	11	21,22	NU	NU	42,43	NU	43	51	61,62	NU	NU	82,83	NU	81	NU	51	41	NU
RED		128			101		*		134			107						
YELLOW	*	129			102				135			108						
GREEN		130			103				136			109						
RED ARROW													A121	A124		A114	A101	
YELLOW ARROW							132						A122	A125		A115	A102	
FLASHING YELLOW ARROW													A123	A126		A116	A103	
GREEN ARROW	127						133	133										

NU = Not Used

* Denotes install load resistor. See load resistor installation detail this sheet.

* See pictorial of head wiring in detail below.

INPUT FILE POSITION LAYOUT

(front view)

FILE	1	2	3	4	5	6	7	8	9	10	11	12	13	14
U	∅ 1	NOT USED	∅ 3	∅ 4	∅ 5	∅ 6	∅ 7	∅ 8	∅ 9	∅ 10	∅ 11	∅ 12	∅ 13	∅ 14
L	1A	2A	3A	4A	5A	6A	7A	8A	9A	10A	11A	12A	13A	14A
U	∅ 5	∅ 6	∅ 7	∅ 8	∅ 9	∅ 10	∅ 11	∅ 12	∅ 13	∅ 14	∅ 15	∅ 16	∅ 17	∅ 18
L	5A	6A	7A	8A	9A	10A	11A	12A	13A	14A	15A	16A	17A	18A

EX.: 1A, 2A, ETC. = LOOP NO.'S
 FS = FLASH SENSE
 ST = STOP TIME
 * Wired Input - Do not populate slot with detector card

INPUT FILE CONNECTION & PROGRAMMING CHART

LOOP NO.	LOOP TERMINAL	INPUT FILE POS.	PIN NO.	INPUT ASSIGNMENT NO.	DETECTOR NO.	NEMA PHASE	CALL	EXTEND	FULL TIME DELAY	STRETCH TIME	DELAY TIME
1A ¹	TB2-1,2	J1U	56	18	1	1	Y	Y			15
2A	TB2-7,8	J2L	43	5	12	2	Y	Y			
4A	TB4-9,10	J6U	41	3	4	4	Y	Y			3
4B	TB4-11,12	J6L	45	7	14	4	Y	Y			
5A ²	TB3-1,2	J1U	55	17	5	5	Y	Y			15
5B	TB3-5,6	J2U	40	2	6	5	Y	Y			
6A	TB3-7,8	J2L	44	6	16	6	Y	Y			
8A	TB5-9,10	J6U	42	4	8	8	Y	Y			3
8B	TB5-11,12	J6L	46	8	18	8	Y	Y			10

- Add jumper from J1-W to J4-W, on rear of input file.
- Add jumper from J1-W to J4-W, on rear of input file.

INPUT FILE POSITION LEGEND: J2L

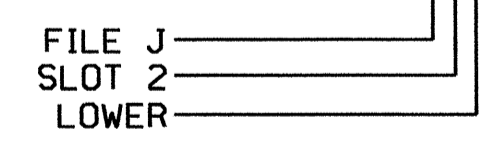

FYA SIGNAL WIRING DETAIL

(wire signal heads as shown)

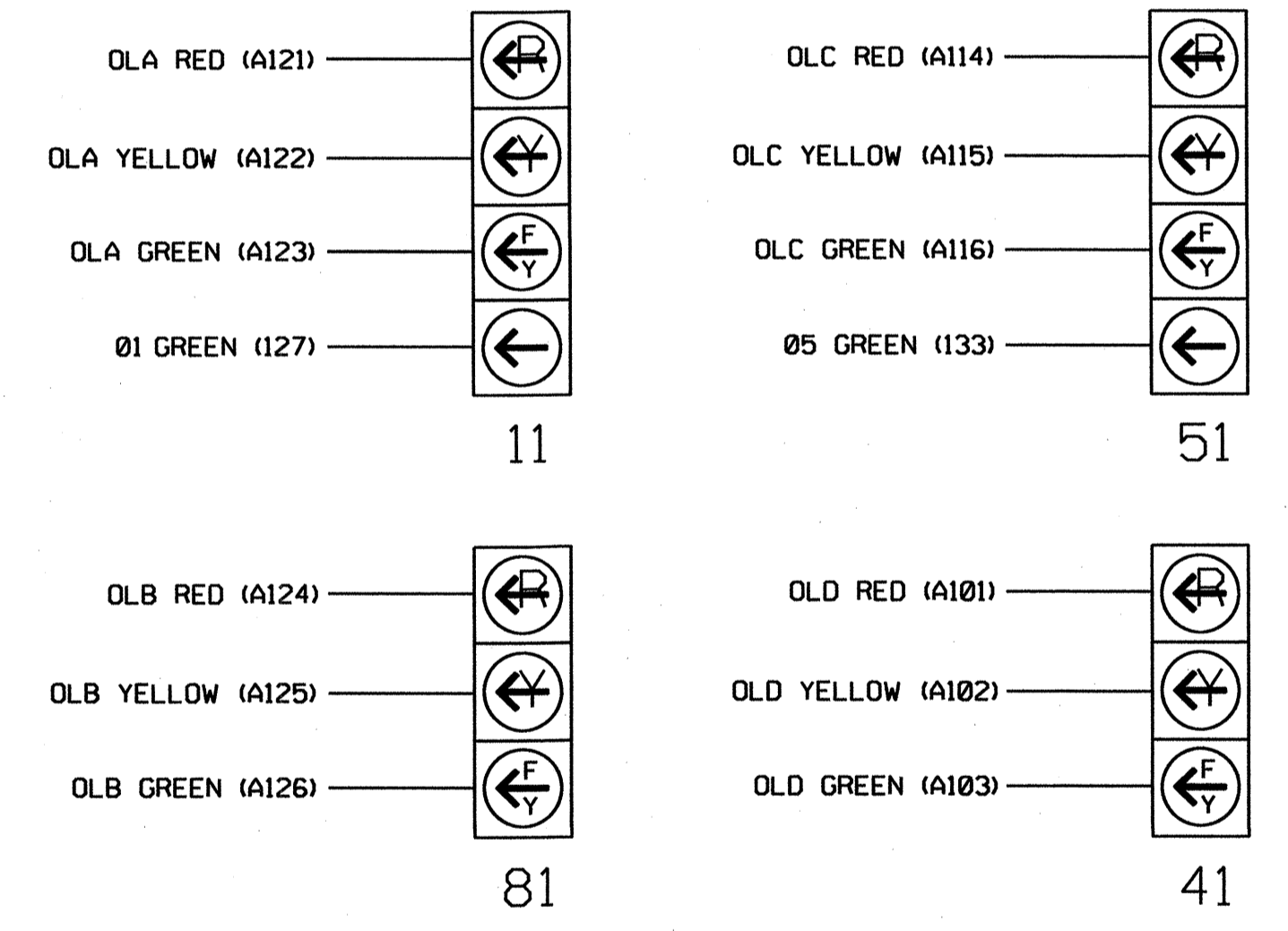

NOTE

The sequence display for signal heads 11 and 51 requires special logic programming. See sheet 2 for programming instructions.

LOAD RESISTOR INSTALLATION DETAIL

(install resistors as shown below)

VALUE (ohms)	WATTAGE
1.5K - 1.9K	25W (min)
2.0K - 3.0K	10W (min)

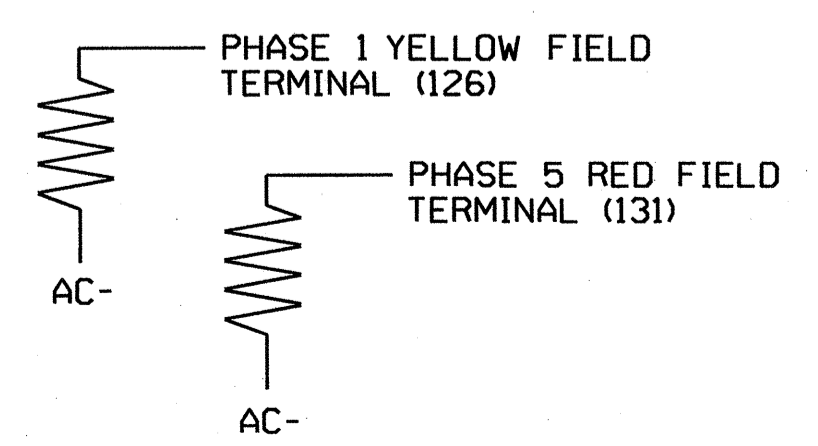

THIS ELECTRICAL DETAIL IS FOR THE SIGNAL DESIGN: 05-0511T1
 DESIGNED: June 2012
 SEALED: 7/31/12
 REVISED: N/A

Signal Upgrade - Temporary Design 1 (TMP Phase I) - Sheet 1 of 2

ELECTRICAL AND PROGRAMMING DETAILS FOR:

US 501/NC 49
 (N. Madison Blvd./Virgilinea Rd.)
 at
 US 501/SR 1601 (N. Main St.)

Division 5 Person County Roxboro

PLAN DATE: July 2012 REVIEWED BY: JTR

PREPARED BY: S. Armstrong REVIEWED BY:

REVISIONS: _____ INIT. DATE

750 N. Greenfield Pkwy, Garner, NC 27529

SEAL: NORTH CAROLINA PROFESSIONAL ENGINEER SEAL 008453 JOHN T. ROWE, JR.

SIGNATURE: _____ DATE: 8-7-12

SIG. INVENTORY NO. 05-0511T1

LOGICAL I/O PROCESSOR PROGRAMMING DETAIL TO PRODUCE SPECIAL FYA-PPLT SIGNAL SEQUENCE

(program controller as shown below)

- FROM MAIN MENU PRESS '2' (PHASE CONTROL), THEN '1' (PHASE CONTROL FUNCTIONS). SCROLL TO THE BOTTOM OF THE MENU AND ENABLE ACT LOGIC COMMANDS 1, 2, 3, 4, 5 AND 6.
- FROM MAIN MENU PRESS '6' (OUTPUTS), THEN '3' (LOGICAL I/O PROCESSOR).

LOGICAL I/O COMMAND #1 (+/-COMMAND#)
IF ACTIVE PHASE #1 IS ON
AND RED CLEAR ON PHASE #1 IS ON

NOTE: LOGIC FOR PHASE 1 RED CLEAR WHEN TRANSITIONING FROM PHASE 1 TO PHASE 2 (HEAD 11).

SCROLL DOWN

THEN:
SET OUTPUT ASSIGNMENT #50 ON
SET OUTPUT ASSIGNMENT #51 OFF

PRESS '+'

LOGICAL I/O COMMAND #2 (+/-COMMAND#)
IF ACTIVE PHASE #1 IS ON

NOTE: LOGIC FOR SWITCHING FLASHING YELLOW ARROW "OFF" DURING PHASE 1 (HEAD 11).

SCROLL DOWN

THEN:
SET OUTPUT ASSIGNMENT #52 OFF

PRESS '+'

LOGICAL I/O COMMAND #3 (+/-COMMAND#)
IF YELLOW ON PHASE #1 IS ON

NOTE: LOGIC FOR YELLOW ARROW CLEARANCE FROM PHASE 1 (HEAD 11).

SCROLL DOWN

THEN:
SET OUTPUT ASSIGNMENT #51 ON

PRESS '+'

LOGICAL I/O COMMAND #4 (+/-COMMAND#)
IF ACTIVE PHASE #5 IS ON
AND RED CLEAR ON PHASE #5 IS ON

NOTE: LOGIC FOR PHASE 5 RED CLEAR WHEN TRANSITIONING FROM PHASE 5 TO PHASE 6 (HEAD 51).

SCROLL DOWN

THEN:
SET OUTPUT ASSIGNMENT #42 ON
SET OUTPUT ASSIGNMENT #43 OFF

PRESS '+'

LOGICAL I/O COMMAND #5 (+/-COMMAND#)
IF ACTIVE PHASE #5 IS ON

NOTE: LOGIC FOR SWITCHING FLASHING YELLOW ARROW "OFF" DURING PHASE 5 (HEAD 51).

SCROLL DOWN

THEN:
SET OUTPUT ASSIGNMENT #44 OFF

PRESS '+'

LOGICAL I/O COMMAND #6 (+/-COMMAND#)
IF YELLOW ON PHASE #5 IS ON

NOTE: LOGIC FOR YELLOW ARROW CLEARANCE FROM PHASE 5 (HEAD 51).

SCROLL DOWN

THEN:
SET OUTPUT ASSIGNMENT #43 ON

PRESS '+'

LOGIC I/O PROCESSOR PROGRAMMING COMPLETE

OUTPUT REFERENCE SCHEDULE

OUTPUT 42 = Overlap C Red
OUTPUT 43 = Overlap C Yellow
OUTPUT 44 = Overlap C Green
OUTPUT 50 = Overlap A Red
OUTPUT 51 = Overlap A Yellow
OUTPUT 52 = Overlap A Green

OVERLAP PROGRAMMING DETAIL

(program controller as shown below)

FROM MAIN MENU PRESS '8' (OVERLAPS), THEN '1' (VEHICLE OVERLAP SETTINGS).

PAGE 1: VEHICLE OVERLAP 'A' SETTINGS
PHASE: 12345678910111213141516
VEH OVL PARENTS: XX
VEH OVL NOT VEH:
VEH OVL NOT PED:
VEH OVL GRN EXT:
STARTUP COLOR: - RED - YELLOW - GREEN
FLASH COLORS: - RED - YELLOW X GREEN
SELECT VEHICLE OVERLAP OPTIONS: (Y/N)
FLASH YELLOW IN CONTROLLER FLASH?...Y
GREEN EXTENSION (0-255 SEC)...0
YELLOW CLEAR (0=PARENT.3-25.5 SEC)...0.0
RED CLEAR (0=PARENT.0.1-25.5 SEC)...0.0
OUTPUT AS PHASE # (0=NONE, 1-16)...0

← NOTICE GREEN FLASH

PRESS '+'

PAGE 1: VEHICLE OVERLAP 'B' SETTINGS
PHASE: 12345678910111213141516
VEH OVL PARENTS: X
VEH OVL NOT VEH:
VEH OVL NOT PED:
VEH OVL GRN EXT:
STARTUP COLOR: - RED - YELLOW - GREEN
FLASH COLORS: - RED - YELLOW X GREEN
SELECT VEHICLE OVERLAP OPTIONS: (Y/N)
FLASH YELLOW IN CONTROLLER FLASH?...N
GREEN EXTENSION (0-255 SEC)...0
YELLOW CLEAR (0=PARENT.3-25.5 SEC)...0.0
RED CLEAR (0=PARENT.0.1-25.5 SEC)...0.0
OUTPUT AS PHASE # (0=NONE, 1-16)...0

← NOTICE GREEN FLASH

PRESS '+'

PAGE 1: VEHICLE OVERLAP 'C' SETTINGS
PHASE: 12345678910111213141516
VEH OVL PARENTS: XX
VEH OVL NOT VEH:
VEH OVL NOT PED:
VEH OVL GRN EXT:
STARTUP COLOR: - RED - YELLOW - GREEN
FLASH COLORS: - RED - YELLOW X GREEN
SELECT VEHICLE OVERLAP OPTIONS: (Y/N)
FLASH YELLOW IN CONTROLLER FLASH?...Y
GREEN EXTENSION (0-255 SEC)...0
YELLOW CLEAR (0=PARENT.3-25.5 SEC)...0.0
RED CLEAR (0=PARENT.0.1-25.5 SEC)...0.0
OUTPUT AS PHASE # (0=NONE, 1-16)...0

← NOTICE GREEN FLASH

PRESS '+'

PAGE 1: VEHICLE OVERLAP 'D' SETTINGS
PHASE: 12345678910111213141516
VEH OVL PARENTS: X
VEH OVL NOT VEH:
VEH OVL NOT PED:
VEH OVL GRN EXT:
STARTUP COLOR: - RED - YELLOW - GREEN
FLASH COLORS: - RED - YELLOW X GREEN
SELECT VEHICLE OVERLAP OPTIONS: (Y/N)
FLASH YELLOW IN CONTROLLER FLASH?...N
GREEN EXTENSION (0-255 SEC)...0
YELLOW CLEAR (0=PARENT.3-25.5 SEC)...0.0
RED CLEAR (0=PARENT.0.1-25.5 SEC)...0.0
OUTPUT AS PHASE # (0=NONE, 1-16)...0

← NOTICE GREEN FLASH

PRESS '+'

OVERLAP PROGRAMMING COMPLETE

FLASHER CIRCUIT MODIFICATION DETAIL

IN ORDER TO INSURE THAT SIGNALS FLASH CONCURRENTLY ON THE SAME APPROACH, MAKE THE FOLLOWING FLASHER CIRCUIT CHANGES:

- ON REAR OF PDA - REMOVE WIRE FROM TERM. T2-4 AND TERMINATE ON T2-2.
- ON REAR OF PDA - REMOVE WIRE FROM TERM. T2-5 AND TERMINATE ON T2-3.
- REMOVE FLASHER UNIT 2.

THE CHANGES LISTED ABOVE TIES ALL PHASES AND OVERLAPS TO FLASHER UNIT 1.

THIS ELECTRICAL DETAIL IS FOR THE SIGNAL DESIGN: 05-0511T1
DESIGNED: June 2012
SEALED: 7/31/12
REVISED: N/A

Signal Upgrade - Temporary Design 1 (TMP Phase I) - Sheet 2 of 2

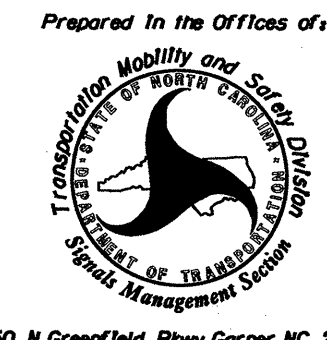
ELECTRICAL AND PROGRAMMING DETAILS FOR: Prepared in the Offices of:  750 N. Greenfield Pkwy, Garner, NC 27529	US 501/NC 49 (N. Madison Blvd./Virgilina Rd.) at US 501/SR 1601 (N. Main St.)		SEAL NORTH CAROLINA PROFESSIONAL ENGINEER SEAL 008453 JOHN T. ROWE, JR. SIGNATURE DATE 8-3-12
	Division 5 PLAN DATE: July 2012 PREPARED BY: S. Armstrong	Person County REVIEWED BY: JTR REVIEWED BY:	

EDI MODEL 2018ECL-NC CONFLICT MONITOR PROGRAMMING DETAIL

(remove jumpers and set switches as shown)

REMOVE DIODE JUMPERS 1-5, 1-6, 1-9, 1-11, 2-5, 2-6, 2-9, 2-11, 4-8, 4-10, 4-12, 5-9, 5-11, 6-9, 6-11, 8-10, 8-12, 9-11, and 10-12.

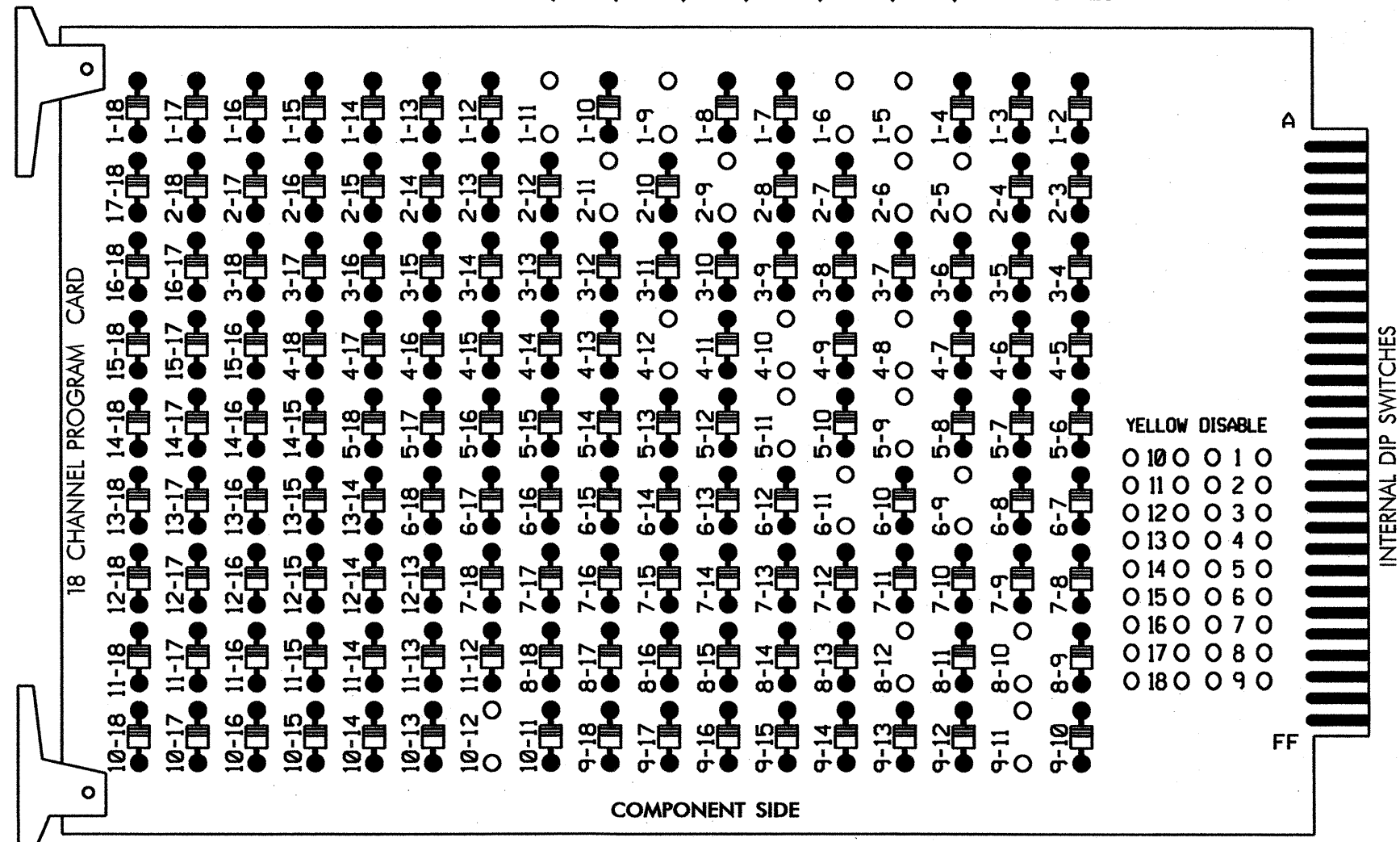

REMOVE JUMPERS AS SHOWN

NOTES:

- Card is provided with all diode jumpers in place. Removal of any jumper allows its channels to run concurrently.
- Ensure jumpers SEL2-SEL5 and SEL9 are present on the monitor board.
- Ensure that Red Enable is active at all times during normal operation.
- Connect serial cable from conflict monitor to comm. port 1 of 2070 controller. Ensure conflict monitor communicates with 2070.

NOTES

- To prevent "flash-conflict" problems, insert red flash program blocks for all unused vehicle load switches in the output file. The installer shall verify that signal heads flash in accordance with the Signal Plans.
- Program phases 4 and 8 for Dual Entry.
- Enable Simultaneous Gap-Out for all phases.
- Program phases 2 and 6 for Start Up In Green.
- Program phases 2 and 6 for Yellow Flash, and overlaps 1 and 2 as Wag Overlaps.

EQUIPMENT INFORMATION

CONTROLLER.....2070L
 CABINET.....332 W/ AUX
 SOFTWARE.....ECONOLITE OASIS
 CABINET MOUNT.....BASE
 OUTPUT FILE POSITIONS...18 WITH AUX. OUTPUT FILE
 LOAD SWITCHES USED.....S1,S2,S5,S7,S8,S11,AUX S1, AUX S2,AUX S4,AUX S5
 PHASES USED.....1,2,4,5,6,8
 OVERLAP "A".....1+2
 OVERLAP "B".....8
 OVERLAP "C".....5+6
 OVERLAP "D".....4

SIGNAL HEAD HOOK-UP CHART

LOAD SWITCH NO.	S1	S2	S3	S4	S5	S6	S7	S8	S9	S10	S11	S12	AUX S1	AUX S2	AUX S3	AUX S4	AUX S5	AUX S6	
CMU CHANNEL NO.	1	2	13	3	4	14	5	6	15	7	8	16	9	10	17	11	12	18	
PHASE	1	2	2 PED	3	4	4 PED	5	6	6 PED	7	8	8 PED	OLA	OLB	SPARE	OLC	OLD	SPARE	
SIGNAL HEAD NO.	11	83	21,22	NU	NU	42,43	NU	43	51	61,62	NU	NU	82,83	NU	11	81	NU	51	41
RED	*	128				101	*		134			107							
YELLOW		129				102			135			108							
GREEN		130				103			136			109							
RED ARROW													A121	A124		A114	A101		
YELLOW ARROW		126						132					A122	A125		A115	A102		
FLASHING YELLOW ARROW													A123	A126		A116	A103		
GREEN ARROW	127	127					133	133											

NU = Not Used
 * Denotes install load resistor. See load resistor installation detail this sheet.
 * See pictorial of head wiring in detail below.

INPUT FILE POSITION LAYOUT

(from view)

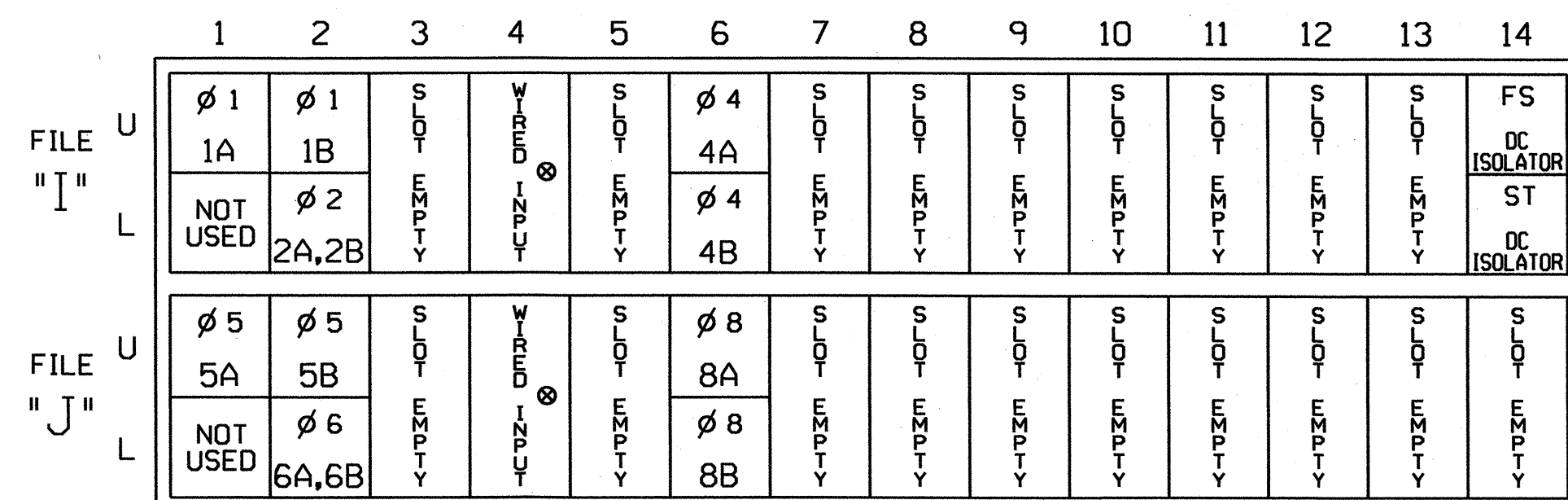

INPUT FILE CONNECTION & PROGRAMMING CHART

LOOP NO.	LOOP TERMINAL	INPUT FILE POS.	PIN NO.	INPUT ASSIGNMENT NO.	DETECTOR NO.	NEMA PHASE	CALL	EXTEND	FULL TIME DELAY	STRETCH TIME	DELAY TIME
1A ¹	TB2-1,2	J1U	56	18	1	1	Y	Y			15
1B	TB2-5,6	J4U	48	10	26	6	Y	Y			15
2A,2B	TB2-7,8	J2L	43	5	12	2	Y	Y			
4A	TB4-9,10	J6U	41	3	4	4	Y	Y			3
4B	TB4-11,12	J6L	45	7	14	4	Y	Y			
5A ²	TB3-1,2	J1U	55	17	5	5	Y	Y			15
5B	TB3-5,6	J2U	40	2	6	5	Y	Y			15
6A,6B	TB3-7,8	J2L	44	6	16	6	Y	Y			
8A	TB5-9,10	J6U	42	4	8	8	Y	Y			3
8B	TB5-11,12	J6L	46	8	18	8	Y	Y			

- Add jumper from I1-W to J4-W, on rear of input file.
- Add jumper from J1-W to I4-W, on rear of input file.

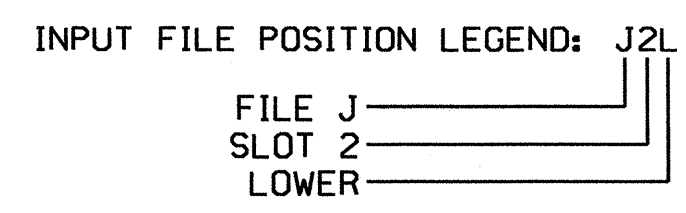

FYA SIGNAL WIRING DETAIL

(wire signal heads as shown)

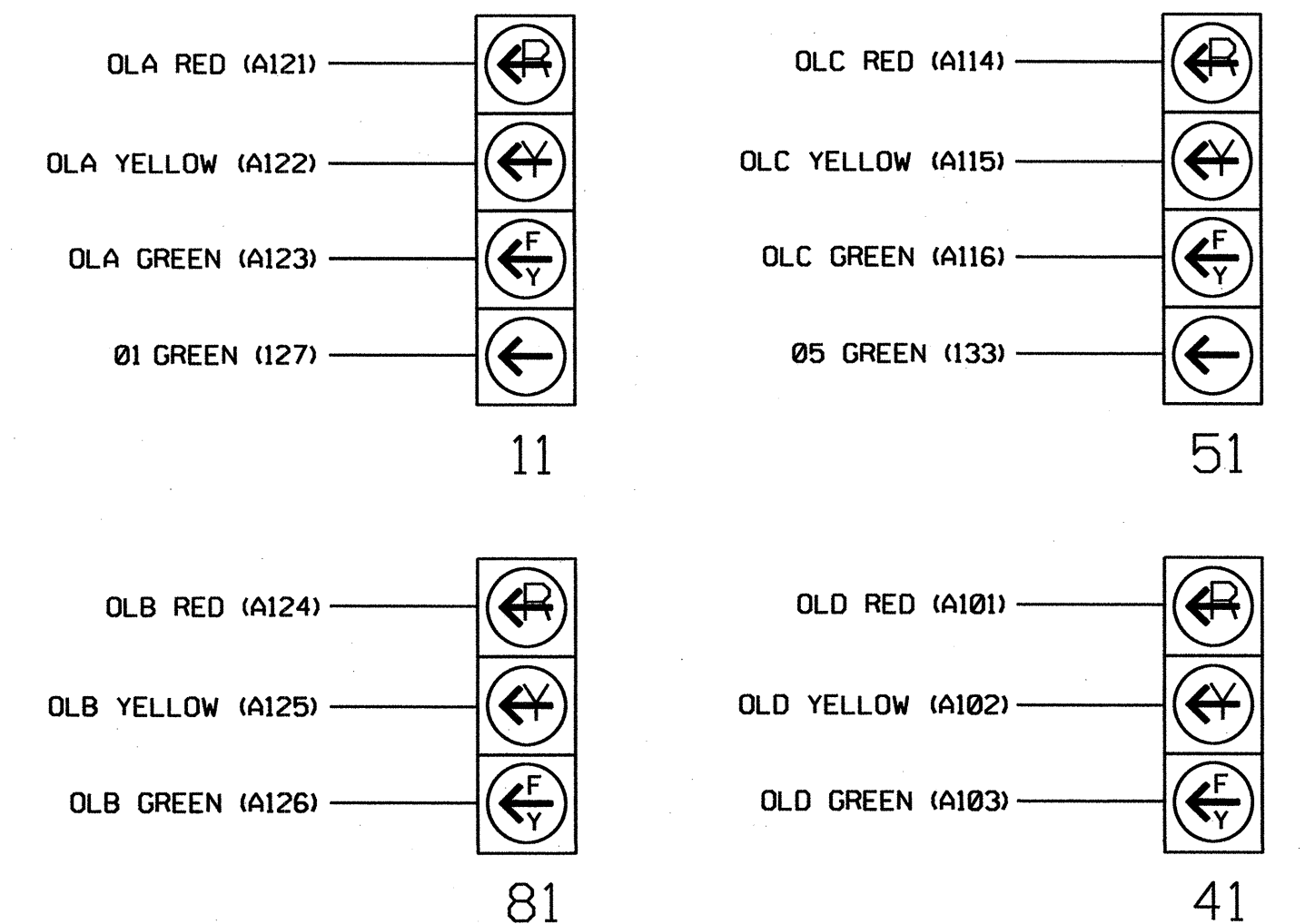

NOTE
 The sequence display for signal heads 11 and 51 requires special logic programming. See sheet 2 for programming instructions.

LOAD RESISTOR INSTALLATION DETAIL

(install resistors as shown below)

VALUE (ohms)	WATTAGE
1.5K - 1.9K	25W (min)
2.0K - 3.0K	10W (min)

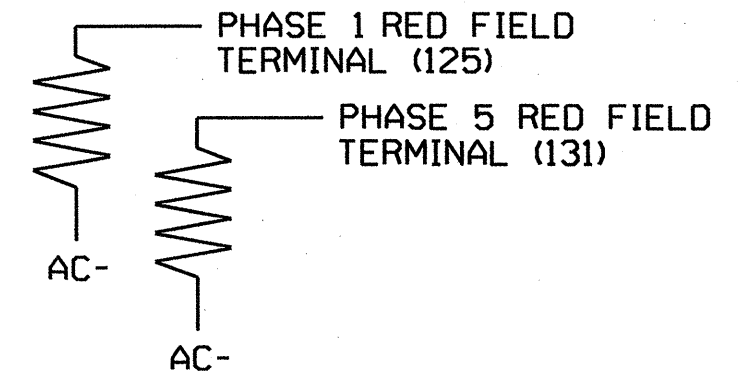

IMPORTANT! Remove resistor shown at left, if present.

THIS ELECTRICAL DETAIL IS FOR THE SIGNAL DESIGN: 05-0511T2
 DESIGNED: June 2012
 SEALED: 7/31/12
 REVISED: N/A

Signal Upgrade - Temporary Design 2 (TMP Phase II and III) - Sheet 1 of 2

ELECTRICAL AND PROGRAMMING DETAILS FOR:

US 501/NC 49
 (N. Madison Blvd./Virgilina Rd.)
 at
 US 501/SR 1601 (N. Main St.)

Division 5 Person County Roxboro

PREPARED BY: S. Armstrong REVIEWED BY: JTR

750 N. Greenfield Pkwy, Garner, NC 27529

SEAL
 NORTH CAROLINA PROFESSIONAL ENGINEER
 SEAL 008453
 JOHN T. ROWE JR.
 SIGNATURE DATE 5/3/12

REVISIONS: INIT. DATE

SIG. INVENTORY NO. 05-0511T2

01-AUG-2012 07:19 301113500115 Signalis\workgroups\sig Mork\mstr\proj\050511_sml_ele.xxx.dgn

LOGICAL I/O PROCESSOR PROGRAMMING DETAIL TO PRODUCE SPECIAL FYA-PPLT SIGNAL SEQUENCE

(program controller as shown below)

- FROM MAIN MENU PRESS '2' (PHASE CONTROL), THEN '1' (PHASE CONTROL FUNCTIONS). SCROLL TO THE BOTTOM OF THE MENU AND ENABLE ACT LOGIC COMMANDS 1, 2, 3, 4, 5 AND 6.
- FROM MAIN MENU PRESS '6' (OUTPUTS), THEN '3' (LOGICAL I/O PROCESSOR).

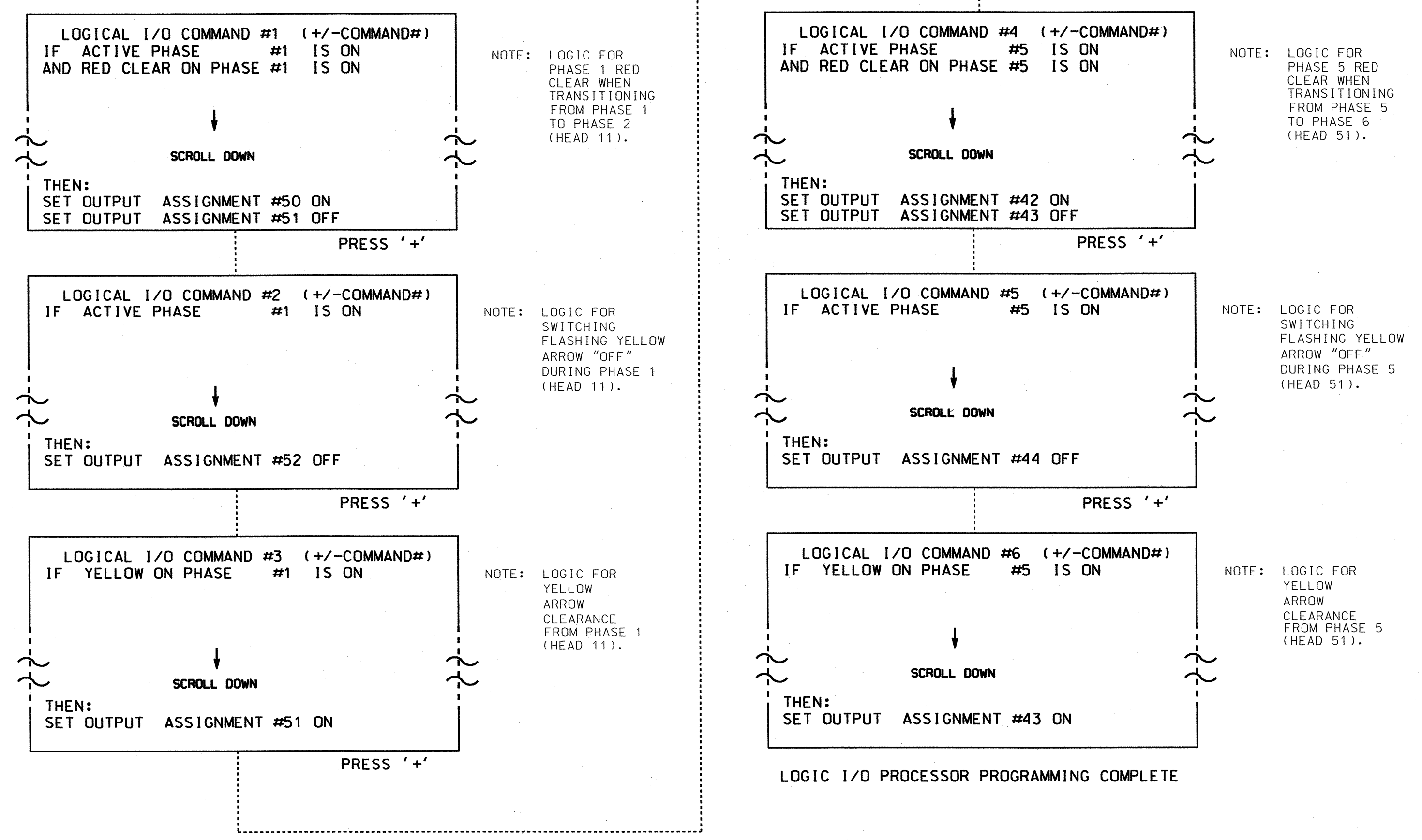

OUTPUT REFERENCE SCHEDULE

OUTPUT 42 = Overlap C Red
OUTPUT 43 = Overlap C Yellow
OUTPUT 44 = Overlap C Green
OUTPUT 50 = Overlap A Red
OUTPUT 51 = Overlap A Yellow
OUTPUT 52 = Overlap A Green

OVERLAP PROGRAMMING DETAIL

(program controller as shown below)

FROM MAIN MENU PRESS '8' (OVERLAPS), THEN '1' (VEHICLE OVERLAP SETTINGS).

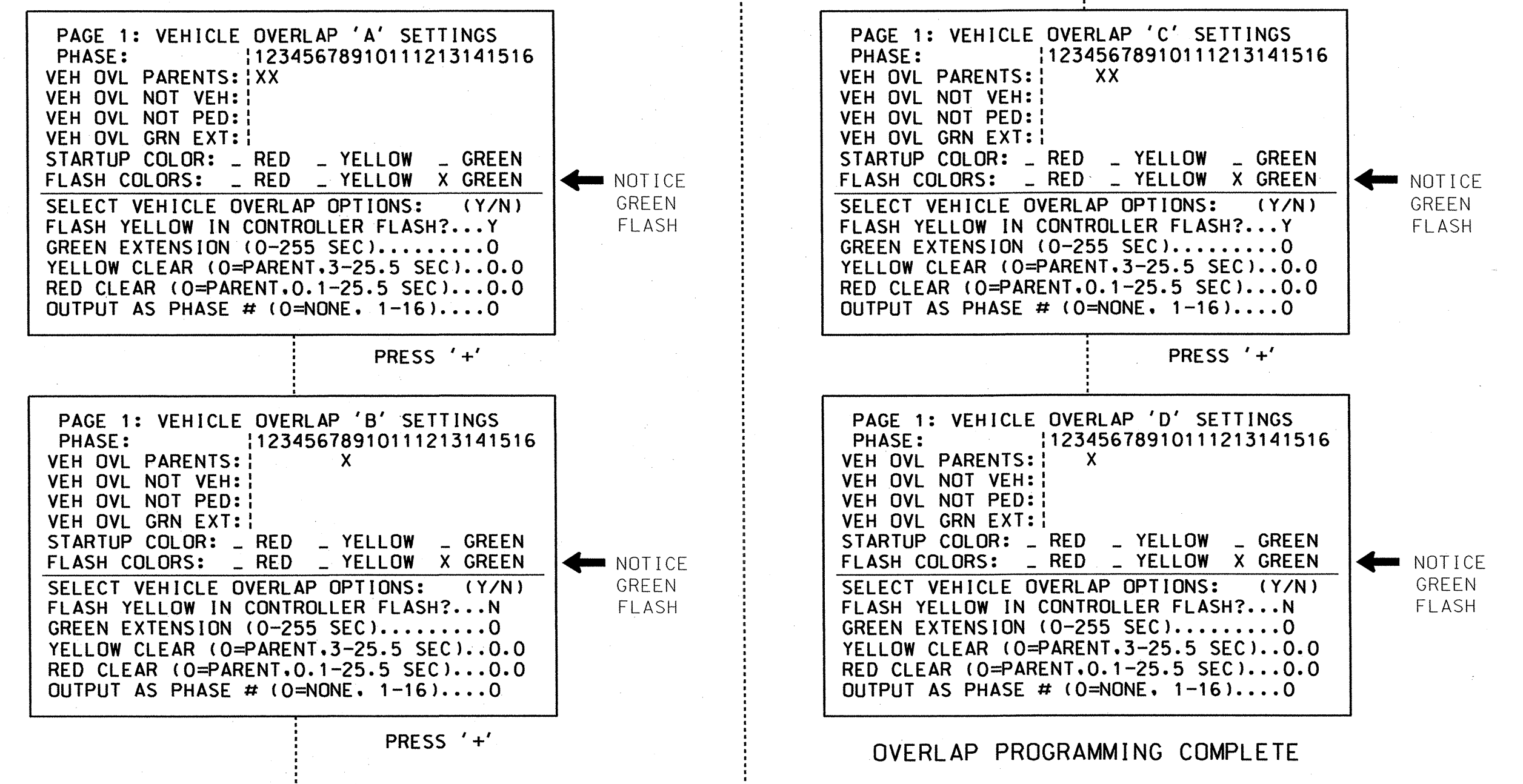

FLASHER CIRCUIT MODIFICATION DETAIL

IN ORDER TO INSURE THAT SIGNALS FLASH CONCURRENTLY ON THE SAME APPROACH, MAKE THE FOLLOWING FLASHER CIRCUIT CHANGES:

- ON REAR OF PDA - REMOVE WIRE FROM TERM. T2-4 AND TERMINATE ON T2-2.
- ON REAR OF PDA - REMOVE WIRE FROM TERM. T2-5 AND TERMINATE ON T2-3.
- REMOVE FLASHER UNIT 2.

THE CHANGES LISTED ABOVE TIES ALL PHASES AND OVERLAPS TO FLASHER UNIT 1.

THIS ELECTRICAL DETAIL IS FOR THE SIGNAL DESIGN: 05-0511T2
DESIGNED: June 2012
SEALED: 7/31/12
REVISED: N/A

Signal Upgrade - Temporary Design 2 (TMP Phase II and III) - Sheet 2 of 2

	ELECTRICAL AND PROGRAMMING DETAILS FOR:		SEAL	
	(N. Madison Blvd./Virgilina Rd.) at US 501/SR 1601 (N. Main St.)		NORTH CAROLINA PROFESSIONAL ENGINEER SEAL 008453 JOHN T. ROWE, JR.	
Division 5 Person County Roxboro	PLAN DATE: July 2012	REVIEWED BY: JTR	PREPARED BY: S. Armstrong	
REVISIONS	INIT.	DATE	SIGNATURE: <i>[Signature]</i> DATE: 8-3-12	
750 N. Greenfield Pkwy, Garner, NC 27529			SIG. INVENTORY NO. 05-0511T2	

EDI MODEL 2018ECL-NC CONFLICT MONITOR PROGRAMMING DETAIL

(remove jumpers and set switches as shown)

REMOVE DIODE JUMPERS 1-5, 1-6, 1-9, 1-11, 2-5, 2-6, 2-9, 2-11, 4-8, 4-10, 4-12, 5-9, 5-11, 6-9, 6-11, 8-10, 8-12, 9-11, and 10-12.

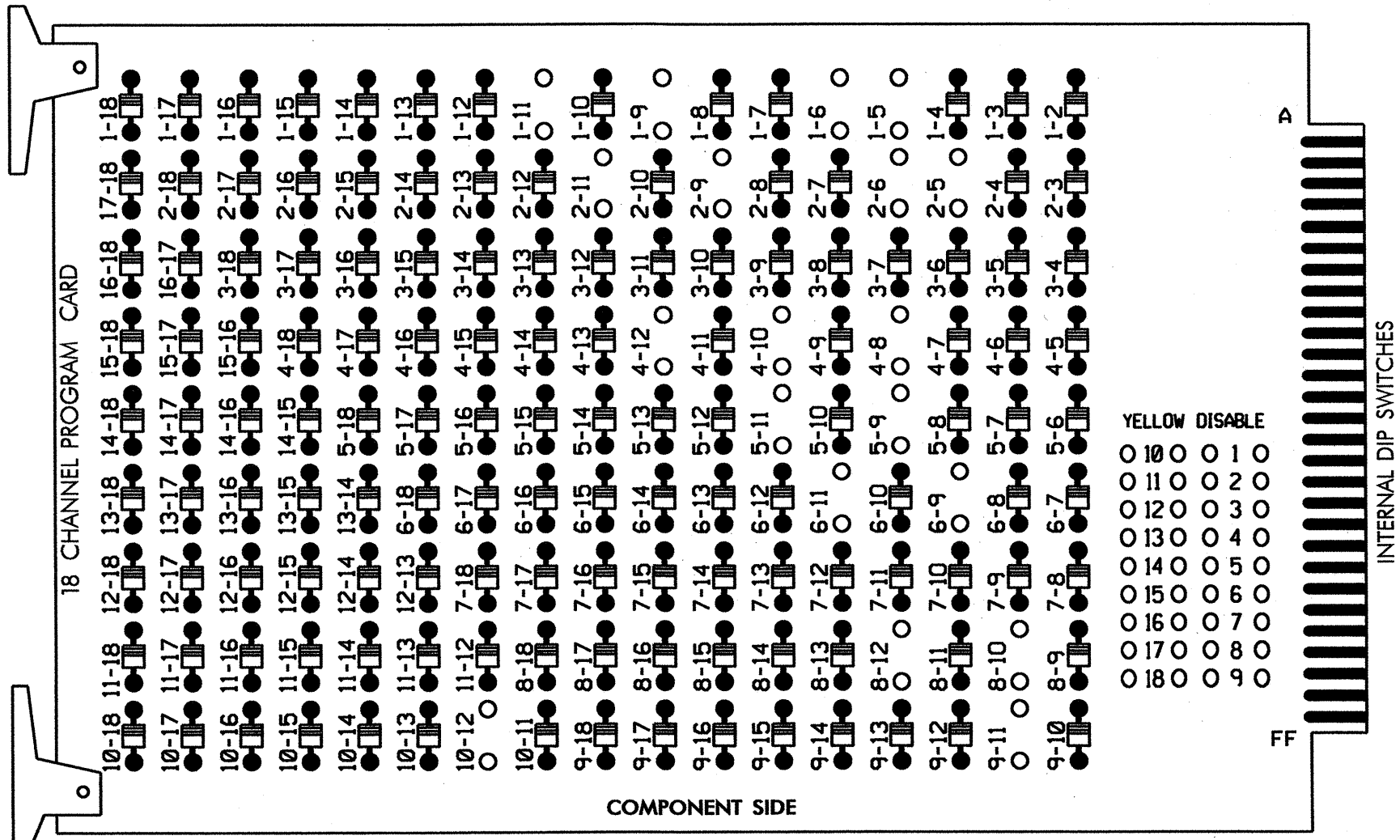

REMOVE JUMPERS AS SHOWN

NOTES:

- Card is provided with all diode jumpers in place. Removal of any jumper allows its channels to run concurrently.
- Ensure jumpers SEL2-SEL5 and SEL9 are present on the monitor board.
- Ensure that Red Enable is active at all times during normal operation.
- Connect serial cable from conflict monitor to comm. port 1 of 2070 controller. Ensure conflict monitor communicates with 2070.

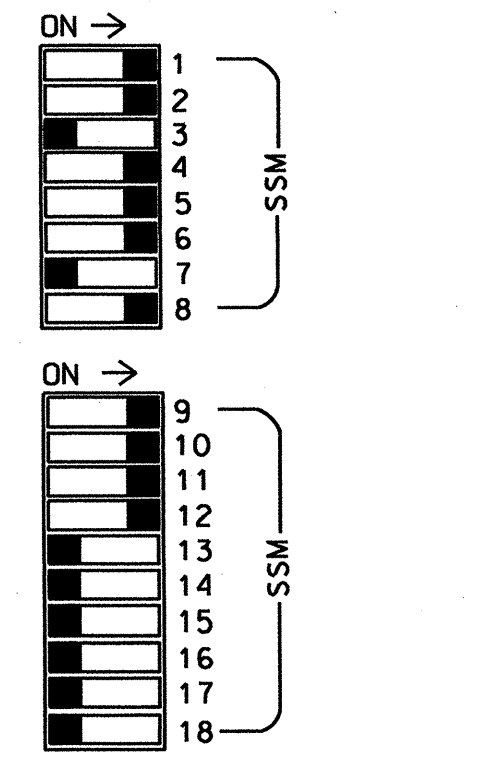
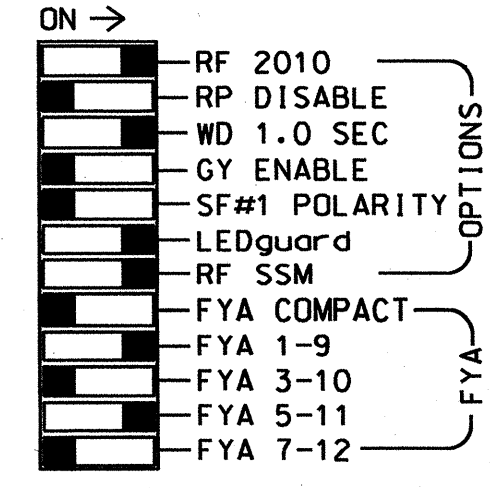
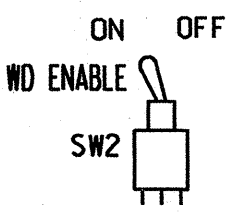

■ = DENOTES POSITION OF SWITCH

NOTES

- To prevent "flash-conflict" problems, insert red flash program blocks for all unused vehicle load switches in the output file. The installer shall verify that signal heads flash in accordance with the Signal Plans.
- Program phases 4 and 8 for Dual Entry.
- Enable Simultaneous Gap-Out for all phases.
- Program phases 2 and 6 for Start Up In Green.
- Program phases 2 and 6 for Yellow Flash, and overlaps 1 and 2 as Wag Overlaps.

EQUIPMENT INFORMATION

CONTROLLER.....2070L
 CABINET.....332 W/ AUX
 SOFTWARE.....ECONOLITE OASIS
 CABINET MOUNT.....BASE
 OUTPUT FILE POSITIONS...18 WITH AUX. OUTPUT FILE
 LOAD SWITCHES USED.....S1,S2,S5,S7,S8,S11,AUX S1,
 AUX S2,AUX S4,AUX S5
 PHASES USED.....1,2,4,5,6,8
 OVERLAP "A".....1+2
 OVERLAP "B".....8
 OVERLAP "C".....5+6
 OVERLAP "D".....4

SIGNAL HEAD HOOK-UP CHART

LOAD SWITCH NO.	S1	S2	S3	S4	S5	S6	S7	S8	S9	S10	S11	S12	AUX S1	AUX S2	AUX S3	AUX S4	AUX S5	AUX S6	
CMU CHANNEL NO.	1	2	13	3	4	14	5	6	15	7	8	16	9	10	17	11	12	18	
PHASE	1	2	2 PED	3	4	4 PED	5	6	6 PED	7	8	8 PED	OLA	OLB	SPARE	OLC	OLD	SPARE	
SIGNAL HEAD NO.	11	83	21,22	NU	NU	42,43	NU	43	51	61,62	NU	NU	82,83	NU	81	NU	51	41	NU
RED	*	128				101	*			134			107						
YELLOW			129			102				135			108						
GREEN			130			103				136			109						
RED ARROW													A121	A124		A114	A101		
YELLOW ARROW	126							132					A122	A125		A115	A102		
FLASHING YELLOW ARROW													A123	A126		A116	A103		
GREEN ARROW	127	127					133	133											

NU = Not Used

* Denotes install load resistor. See load resistor installation detail this sheet.

★ See pictorial of head wiring in detail below.

FYA SIGNAL WIRING DETAIL

(wire signal heads as shown)

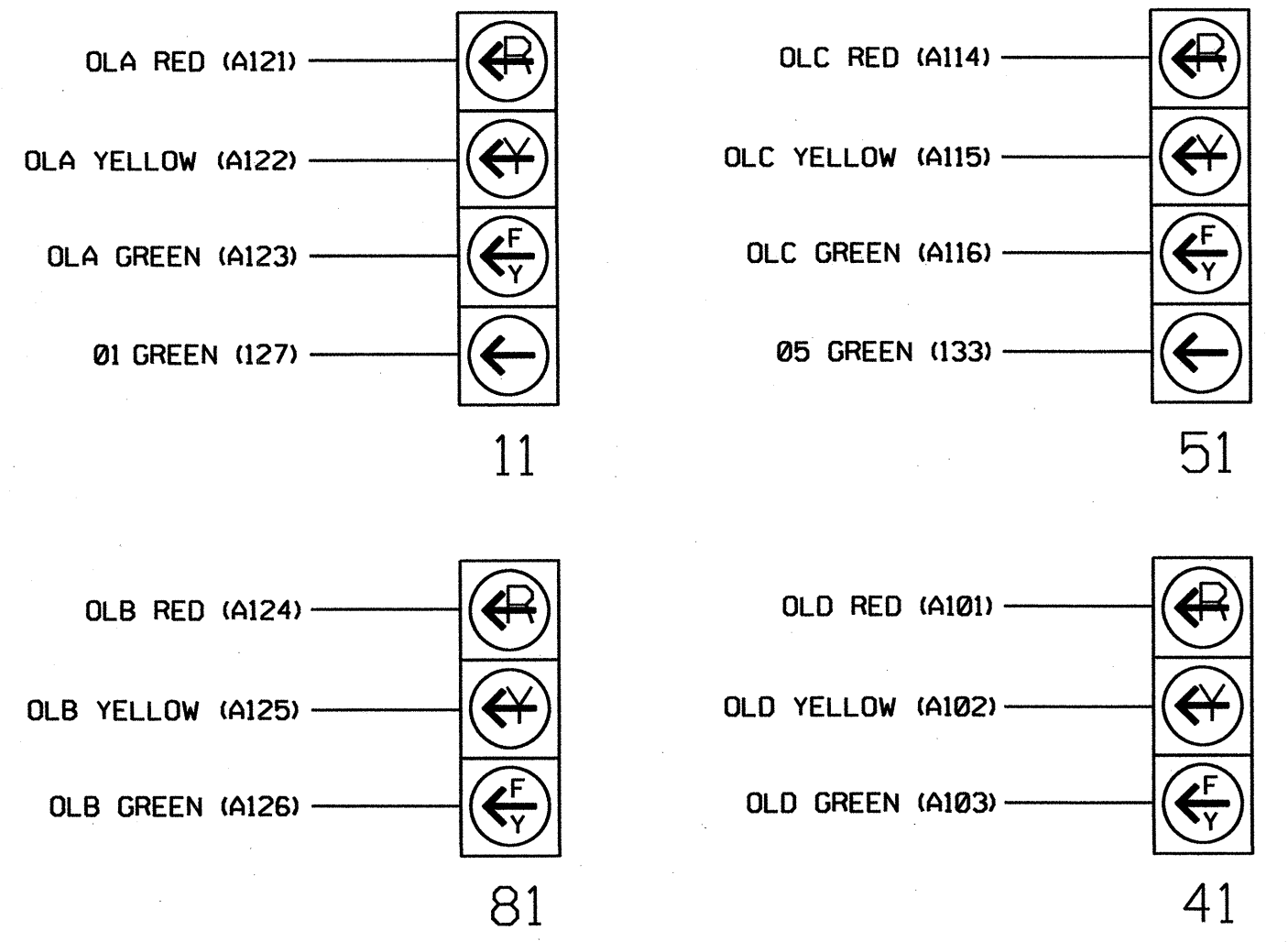

NOTE

The sequence display for signal heads 11 and 51 requires special logic programming. See sheet 2 for programming instructions.

INPUT FILE POSITION LAYOUT

(front view)

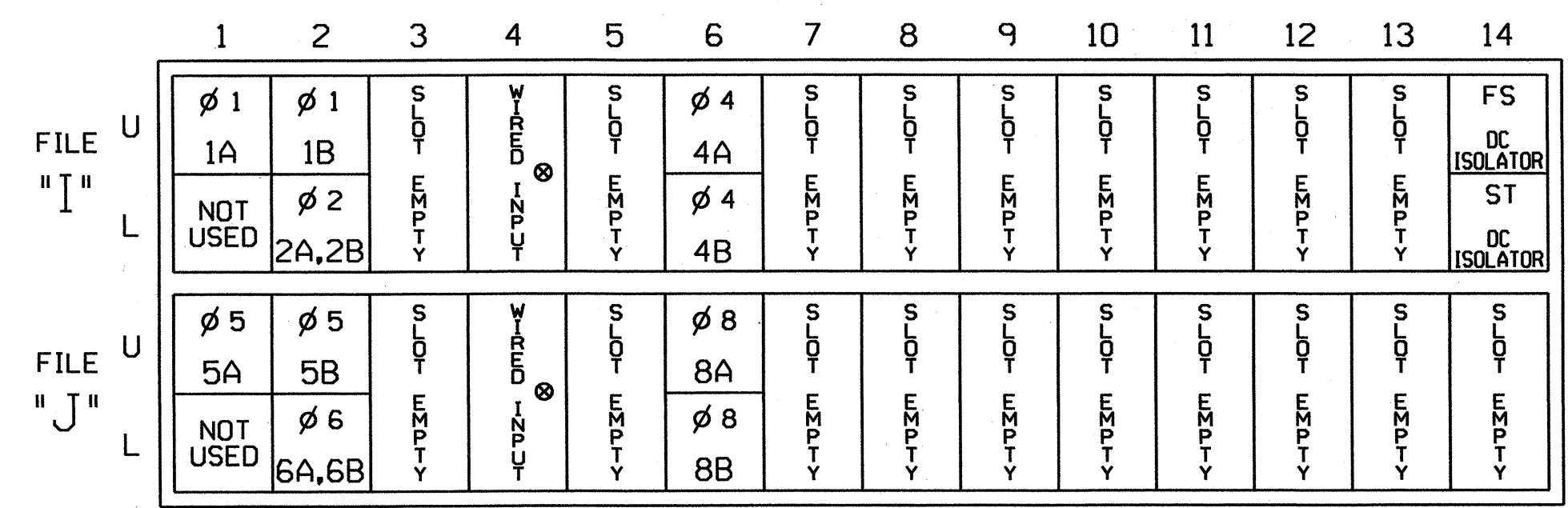

EX.: 1A, 2A, ETC. = LOOP NO.'S

FS = FLASH SENSE
 ST = STOP TIME

⊗ Wired Input - Do not populate slot with detector card

INPUT FILE CONNECTION & PROGRAMMING CHART

LOOP NO.	LOOP TERMINAL	INPUT FILE POS.	PIN NO.	INPUT ASSIGNMENT NO.	DETECTOR NO.	NEMA PHASE	CALL	EXTEND	FULL TIME DELAY	STRETCH TIME	DELAY TIME
1A ¹	TB2-1,2	I1U	56	18	1	1	Y	Y			15
	-	J4U	48	10	26	6	Y	Y			
1B	TB2-5,6	I2U	39	1	2	1	Y	Y			15
	2A,2B	TB2-7,8	I2L	43	5	12	2	Y	Y		
4A	TB4-9,10	I6U	41	3	4	4	Y	Y			3
	4B	TB4-11,12	I6L	45	7	14	4	Y	Y		
5A ²	TB3-1,2	J1U	55	17	5	5	Y	Y			15
	-	I4U	47	9	22	2	Y	Y			
5B	TB3-5,6	J2U	40	2	6	5	Y	Y			15
	6A,6B	TB3-7,8	J2L	44	6	16	6	Y	Y		
8A	TB5-9,10	J6U	42	4	8	8	Y	Y			3
	8B	TB5-11,12	J6L	46	8	18	8	Y	Y		

¹Add jumper from I1-W to J4-W, on rear of input file.

²Add jumper from J1-W to I4-W, on rear of input file.

INPUT FILE POSITION LEGEND: J2L

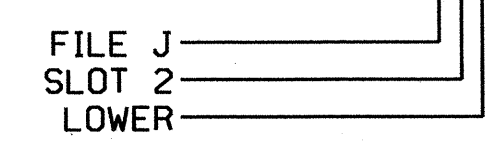

LOAD RESISTOR INSTALLATION DETAIL

(install resistors as shown below)

VALUE (ohms)	WATTAGE
1.5K - 1.9K	25W (min)
2.0K - 3.0K	10W (min)

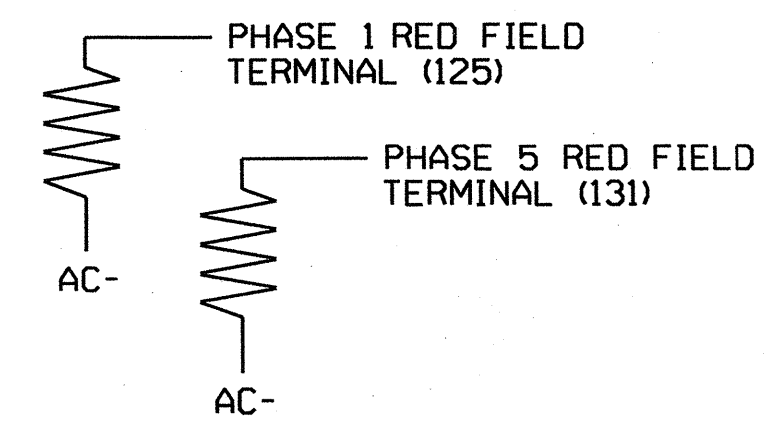

Signal Upgrade - Final Design - Sheet 1 of 2

ELECTRICAL AND PROGRAMMING DETAILS FOR:

Prepared In the Offices of:

750 N. Greenfield Pkwy, Garner, NC 27529

US 501/NC 49
 (N. Madison Blvd./Virgilina Rd.)
 at
 US 501/SR 1601 (N. Main St.)

Division 5 Person County Roxboro

PLAN DATE: July 2012 REVIEWED BY: JTK

PREPARED BY: S. Armstrong REVIEWED BY:

REVISIONS: INIT. DATE

SEAL: 008453

SEAL: 008453

Signature: [Handwritten Signature] DATE: 8-3-12

SIG. INVENTORY NO. 05-0511

LOGICAL I/O PROCESSOR PROGRAMMING DETAIL TO PRODUCE SPECIAL FYA-PPLT SIGNAL SEQUENCE

(program controller as shown below)

- FROM MAIN MENU PRESS '2' (PHASE CONTROL), THEN '1' (PHASE CONTROL FUNCTIONS). SCROLL TO THE BOTTOM OF THE MENU AND ENABLE ACT LOGIC COMMANDS 1, 2, 3, 4, 5 AND 6.
- FROM MAIN MENU PRESS '6' (OUTPUTS), THEN '3' (LOGICAL I/O PROCESSOR).

LOGICAL I/O COMMAND #1 (+/-COMMAND#)
IF ACTIVE PHASE #1 IS ON
AND RED CLEAR ON PHASE #1 IS ON

NOTE: LOGIC FOR PHASE 1 RED CLEAR WHEN TRANSITIONING FROM PHASE 1 TO PHASE 2 (HEAD 11).

SCROLL DOWN

THEN:
SET OUTPUT ASSIGNMENT #50 ON
SET OUTPUT ASSIGNMENT #51 OFF

PRESS '+'

LOGICAL I/O COMMAND #2 (+/-COMMAND#)
IF ACTIVE PHASE #1 IS ON

NOTE: LOGIC FOR SWITCHING FLASHING YELLOW ARROW "OFF" DURING PHASE 1 (HEAD 11).

SCROLL DOWN

THEN:
SET OUTPUT ASSIGNMENT #52 OFF

PRESS '+'

LOGICAL I/O COMMAND #3 (+/-COMMAND#)
IF YELLOW ON PHASE #1 IS ON

NOTE: LOGIC FOR YELLOW ARROW CLEARANCE FROM PHASE 1 (HEAD 11).

SCROLL DOWN

THEN:
SET OUTPUT ASSIGNMENT #51 ON

PRESS '+'

LOGICAL I/O COMMAND #4 (+/-COMMAND#)
IF ACTIVE PHASE #5 IS ON
AND RED CLEAR ON PHASE #5 IS ON

NOTE: LOGIC FOR PHASE 5 RED CLEAR WHEN TRANSITIONING FROM PHASE 5 TO PHASE 6 (HEAD 51).

SCROLL DOWN

THEN:
SET OUTPUT ASSIGNMENT #42 ON
SET OUTPUT ASSIGNMENT #43 OFF

PRESS '+'

LOGICAL I/O COMMAND #5 (+/-COMMAND#)
IF ACTIVE PHASE #5 IS ON

NOTE: LOGIC FOR SWITCHING FLASHING YELLOW ARROW "OFF" DURING PHASE 5 (HEAD 51).

SCROLL DOWN

THEN:
SET OUTPUT ASSIGNMENT #44 OFF

PRESS '+'

LOGICAL I/O COMMAND #6 (+/-COMMAND#)
IF YELLOW ON PHASE #5 IS ON

NOTE: LOGIC FOR YELLOW ARROW CLEARANCE FROM PHASE 5 (HEAD 51).

SCROLL DOWN

THEN:
SET OUTPUT ASSIGNMENT #43 ON

PRESS '+'

LOGIC I/O PROCESSOR PROGRAMMING COMPLETE

OUTPUT REFERENCE SCHEDULE

OUTPUT 42 = Overlap C Red
OUTPUT 43 = Overlap C Yellow
OUTPUT 44 = Overlap C Green
OUTPUT 50 = Overlap A Red
OUTPUT 51 = Overlap A Yellow
OUTPUT 52 = Overlap A Green

OVERLAP PROGRAMMING DETAIL

(program controller as shown below)

FROM MAIN MENU PRESS '8' (OVERLAPS), THEN '1' (VEHICLE OVERLAP SETTINGS).

PAGE 1: VEHICLE OVERLAP 'A' SETTINGS
PHASE: 12345678910111213141516
VEH OVL PARENTS: XX
VEH OVL NOT VEH:
VEH OVL NOT PED:
VEH OVL GRN EXT:
STARTUP COLOR: - RED - YELLOW - GREEN
FLASH COLORS: - RED - YELLOW X GREEN

SELECT VEHICLE OVERLAP OPTIONS: (Y/N)
FLASH YELLOW IN CONTROLLER FLASH?...Y
GREEN EXTENSION (0-255 SEC)...0.0
YELLOW CLEAR (0=PARENT,3-25.5 SEC)...0.0
RED CLEAR (0=PARENT,0.1-25.5 SEC)...0.0
OUTPUT AS PHASE # (0=NONE, 1-16)...0

NOTICE GREEN FLASH

PRESS '+'

PAGE 1: VEHICLE OVERLAP 'B' SETTINGS
PHASE: 12345678910111213141516
VEH OVL PARENTS: X
VEH OVL NOT VEH:
VEH OVL NOT PED:
VEH OVL GRN EXT:
STARTUP COLOR: - RED - YELLOW - GREEN
FLASH COLORS: - RED - YELLOW X GREEN

SELECT VEHICLE OVERLAP OPTIONS: (Y/N)
FLASH YELLOW IN CONTROLLER FLASH?...N
GREEN EXTENSION (0-255 SEC)...0.0
YELLOW CLEAR (0=PARENT,3-25.5 SEC)...0.0
RED CLEAR (0=PARENT,0.1-25.5 SEC)...0.0
OUTPUT AS PHASE # (0=NONE, 1-16)...0

NOTICE GREEN FLASH

PRESS '+'

PAGE 1: VEHICLE OVERLAP 'C' SETTINGS
PHASE: 12345678910111213141516
VEH OVL PARENTS: XX
VEH OVL NOT VEH:
VEH OVL NOT PED:
VEH OVL GRN EXT:
STARTUP COLOR: - RED - YELLOW - GREEN
FLASH COLORS: - RED - YELLOW X GREEN

SELECT VEHICLE OVERLAP OPTIONS: (Y/N)
FLASH YELLOW IN CONTROLLER FLASH?...Y
GREEN EXTENSION (0-255 SEC)...0.0
YELLOW CLEAR (0=PARENT,3-25.5 SEC)...0.0
RED CLEAR (0=PARENT,0.1-25.5 SEC)...0.0
OUTPUT AS PHASE # (0=NONE, 1-16)...0

NOTICE GREEN FLASH

PRESS '+'

PAGE 1: VEHICLE OVERLAP 'D' SETTINGS
PHASE: 12345678910111213141516
VEH OVL PARENTS: X
VEH OVL NOT VEH:
VEH OVL NOT PED:
VEH OVL GRN EXT:
STARTUP COLOR: - RED - YELLOW - GREEN
FLASH COLORS: - RED - YELLOW X GREEN

SELECT VEHICLE OVERLAP OPTIONS: (Y/N)
FLASH YELLOW IN CONTROLLER FLASH?...N
GREEN EXTENSION (0-255 SEC)...0.0
YELLOW CLEAR (0=PARENT,3-25.5 SEC)...0.0
RED CLEAR (0=PARENT,0.1-25.5 SEC)...0.0
OUTPUT AS PHASE # (0=NONE, 1-16)...0

NOTICE GREEN FLASH

PRESS '+'

OVERLAP PROGRAMMING COMPLETE

FLASHER CIRCUIT MODIFICATION DETAIL

IN ORDER TO INSURE THAT SIGNALS FLASH CONCURRENTLY ON THE SAME APPROACH, MAKE THE FOLLOWING FLASHER CIRCUIT CHANGES:

- ON REAR OF PDA - REMOVE WIRE FROM TERM. T2-4 AND TERMINATE ON T2-2.
- ON REAR OF PDA - REMOVE WIRE FROM TERM. T2-5 AND TERMINATE ON T2-3.
- REMOVE FLASHER UNIT 2.

THE CHANGES LISTED ABOVE TIES ALL PHASES AND OVERLAPS TO FLASHER UNIT 1.

THIS ELECTRICAL DETAIL IS FOR THE SIGNAL DESIGN: 05-0511
DESIGNED: June 2012
SEALED: 7/31/12
REVISED: N/A

Signal Upgrade - Final Design - Sheet 2 of 2

ELECTRICAL AND PROGRAMMING DETAILS FOR:

US 501/NC 49
(N. Madison Blvd./Virgilina Rd.)
at
US 501/SR 1601 (N. Main St.)

Division 5 Person County Roxboro

PLAN DATE: July 2012 REVIEWED BY: JTR

PREPARED BY: S. Armstrong REVIEWED BY:

REVISIONS INIT. DATE

750 N. Greenfield Hwy, Garner, NC 27529

SEAL
NORTH CAROLINA PROFESSIONAL ENGINEER
SEAL 008453
JOHN T. ROWE, III
ENGINEER
DATE 8-3-12
SIGNATURE

SIG. INVENTORY NO. 05-0511

EDI MODEL 2018ECL-NC CONFLICT MONITOR

PROGRAMMING DETAIL

(remove jumpers and set switches as shown)

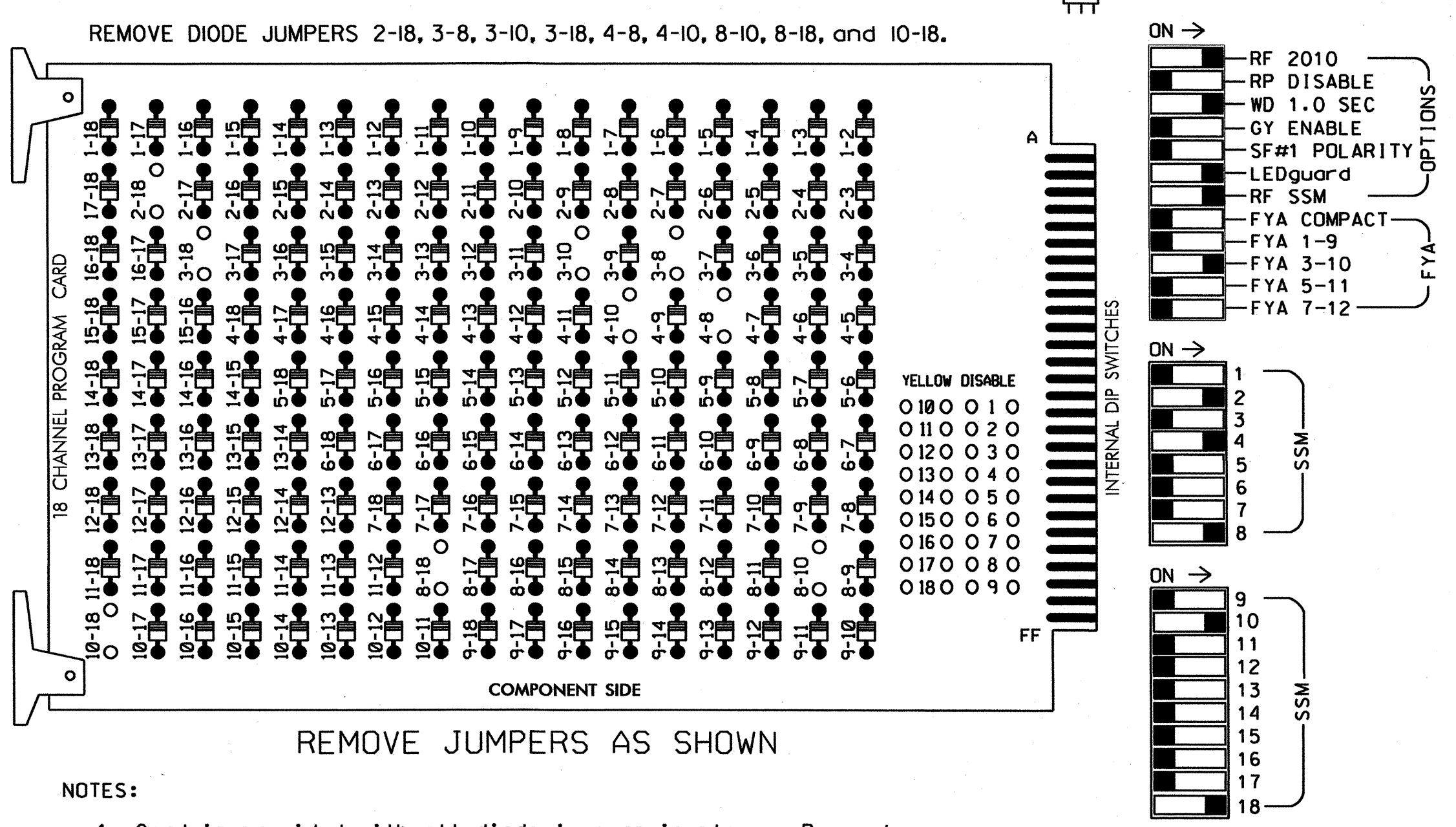

- NOTES:
- Card is provided with all diode jumpers in place. Removal of any jumper allows its channels to run concurrently.
 - Ensure jumpers SEL2-SEL5 and SEL9 are present on the monitor board.
 - Ensure that Red Enable is active at all times during normal operation.
 - Connect serial cable from conflict monitor to comm. port 1 of 2070 controller. Ensure conflict monitor communicates with 2070.

NOTES

- To prevent "flash-conflict" problems, insert red flash program blocks for all unused vehicle load switches in the output file. The installer shall verify that signal heads flash in accordance with the Signal Plans.
- Program phase 4 for Dual Entry.
- Enable Simultaneous Gap-Out for all phases.
- Program phases 4 and 8 for Start Up In Green.
- Program phases 4 and 8 for Yellow Flash, and overlap 2 as Wag Overlaps.

EQUIPMENT INFORMATION

CONTROLLER.....2070L
 CABINET.....332 W/ AUX
 SOFTWARE.....ECONOLITE OASIS
 CABINET MOUNT.....BASE
 OUTPUT FILE POSITIONS...18 WITH AUX. OUTPUT FILE
 LOAD SWITCHES USED.....S2,S4,S5,S11,AUX S2,AUX S6
 PHASES USED.....2,3,4,8
 OVERLAP "A".....NOT USED
 OVERLAP "B".....3+4
 OVERLAP "C".....NOT USED
 OVERLAP "D".....NOT USED
 OVERLAP "E".....NOT USED
 OVERLAP "F".....2+3

SIGNAL HEAD HOOK-UP CHART

LOAD SWITCH NO.	S1	S2	S3	S4	S5	S6	S7	S8	S9	S10	S11	S12	AUX S1	AUX S2	AUX S3	AUX S4	AUX S5	AUX S6
CMU CHANNEL NO.	1	2	13	3	4	14	5	6	15	7	8	16	9	10	17	11	12	18
PHASE	1	2	2 PED	3	4	4 PED	5	6	6 PED	7	8	8 PED	OLA	OLB	SPARE	OLC	OLD	OLF
SIGNAL HEAD NO.	NU	21	NU	31	42,43 44	NU	NU	NU	NU	NU	81,82	NU	NU	31	NU	NU	NU	32,33
RED					101						107							A104
YELLOW				*	102						108							
GREEN					103						109							
RED ARROW		128													A124			
YELLOW ARROW		129													A125			A105
FLASHING YELLOW ARROW															A126			
GREEN ARROW		130		118														A106

NU = Not Used
 * Denotes install load resistor. See load resistor installation detail this sheet.
 * See pictorial of head wiring in detail below.
 NOTE: Outputs for loadswitch AUX S6 must be remapped. See sheet 3.

INPUT FILE POSITION LAYOUT

(from view)

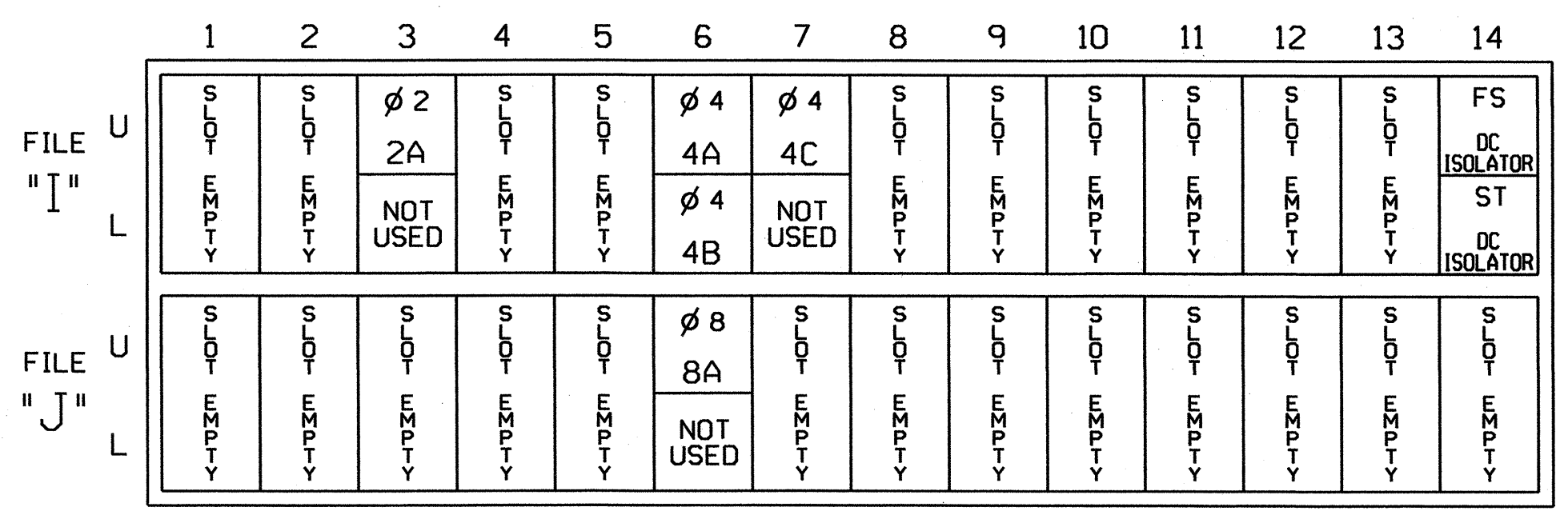

INPUT FILE CONNECTION & PROGRAMMING CHART

LOOP NO.	LOOP TERMINAL	INPUT FILE POS.	PIN NO.	INPUT ASSIGNMENT NO.	DETECTOR NO.	NEMA PHASE	CALL	EXTEND	FULL TIME DELAY	STRETCH TIME	DELAY TIME
2A	TB2-9,10	I3U	63	25	32	2	Y	Y			3
4A	TB4-9,10	I6U	41	3	4	4		Y		2.5	
4B	TB4-11,12	I6L	45	7	14	4	Y	Y			10
4C	TB6-1,2	I7U	65	27	34	4	Y	Y			15
8A	TB5-9,10	J6U	42	4	8	8	Y	Y			

INPUT FILE POSITION LEGEND: J2L

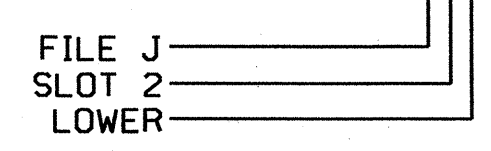

FYA SIGNAL WIRING DETAIL

(wire signal head as shown)

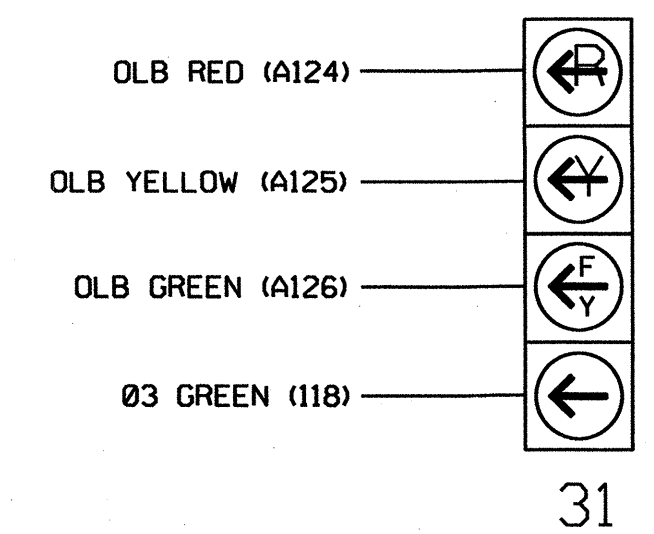

NOTE
 The sequence display for signal head 31 requires special logic programming. See sheet 2 for programming instructions.

LOAD RESISTOR INSTALLATION DETAIL

(install resistor as shown below)

ACCEPTABLE VALUES

VALUE (ohms)	WATTAGE
1.5K - 1.9K	25W (min)
2.0K - 3.0K	10W (min)

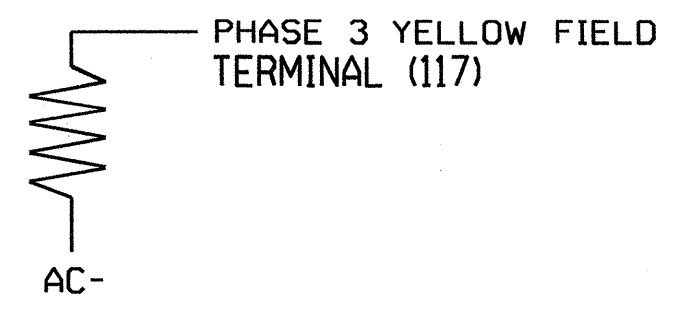

New Installation - Temporary Design 1 (TMP Phase II) - Sheet 1 of 3

ELECTRICAL AND PROGRAMMING DETAILS FOR:

Prepared In the Office of:

 750 N. Grandfield Pkwy, Garner, NC 27529

NC 49 (Virgilina Road) at SR 1532 (Thaxton Road)

Division 5 Person County Roxboro

PLAN DATE: November 2012 REVIEWED BY: JTR

PREPARED BY: S. Armstrong REVIEWED BY:

REVISIONS INIT. DATE

SEAL
 NORTH CAROLINA PROFESSIONAL ENGINEER
 SEAL 008453
 JOHN T. ROWE, III
 SIGNATURE DATE 11-29-12
 SIG. INVENTORY NO. 05-2457T1

29-NOV-2012 06:41 S:\ITS\SI\ITS Signal\working\cupes\sig Mon\mstron\052457-sm_ele_12.dgn samstron

LOGICAL I/O PROCESSOR PROGRAMMING DETAIL TO PRODUCE SPECIAL FYA-PPLT SIGNAL SEQUENCE

(program controller as shown below)

- FROM MAIN MENU PRESS '2' (PHASE CONTROL). THEN '1' (PHASE CONTROL FUNCTIONS). SCROLL TO THE BOTTOM OF THE MENU AND ENABLE ACT LOGIC COMMANDS 1, 2, AND 3.
- FROM MAIN MENU PRESS '6' (OUTPUTS). THEN '3' (LOGICAL I/O PROCESSOR).

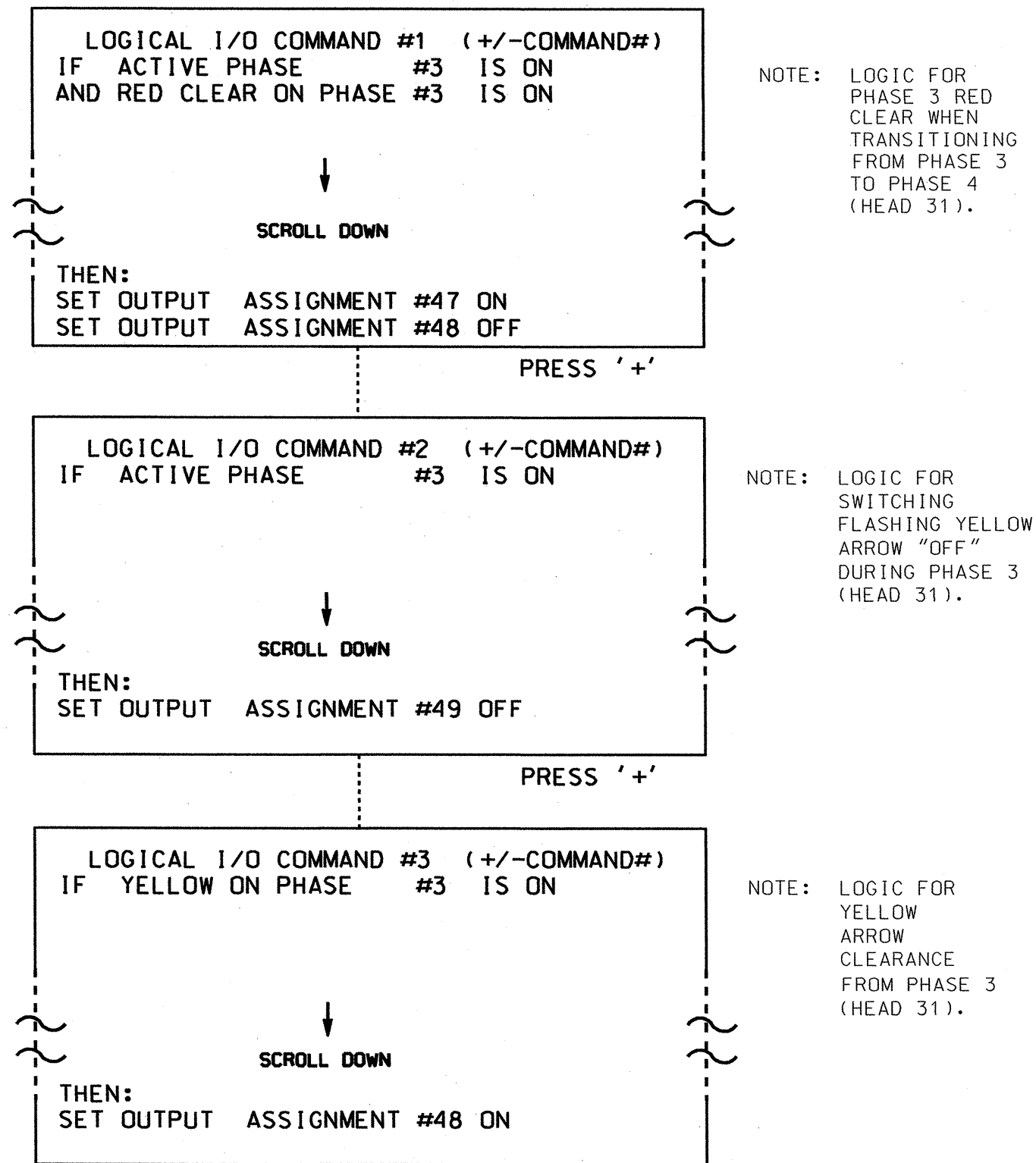

LOGIC I/O PROCESSOR PROGRAMMING COMPLETE

OUTPUT REFERENCE SCHEDULE

OUTPUT 47 = Overlap B Red
OUTPUT 48 = Overlap B Yellow
OUTPUT 49 = Overlap B Green

THIS ELECTRICAL DETAIL IS FOR
THE SIGNAL DESIGN: 05-2457T1
DESIGNED: October 2012
SEALED: 11/26/12
REVISED: N/A

OVERLAP PROGRAMMING DETAIL

(program controller as shown below)

FROM MAIN MENU PRESS '8' (OVERLAPS). THEN '1' (VEHICLE OVERLAP SETTINGS).

PRESS '+' ONCE

```

PAGE 1: VEHICLE OVERLAP 'B' SETTINGS
PHASE: |12345678910111213141516
VEH OVL PARENTS: | XX
VEH OVL NOT VEH: |
VEH OVL NOT PED: |
VEH OVL GRN EXT: |
STARTUP COLOR: - RED - YELLOW - GREEN
FLASH COLORS: - RED - YELLOW X GREEN
SELECT VEHICLE OVERLAP OPTIONS: (Y/N)
FLASH YELLOW IN CONTROLLER FLASH?...Y
GREEN EXTENSION (0-255 SEC)...0.0
YELLOW CLEAR (0=PARENT,3-25.5 SEC)...0.0
RED CLEAR (0=PARENT,0.1-25.5 SEC)...0.0
OUTPUT AS PHASE # (0=NONE, 1-16)...0
    
```

← NOTICE GREEN FLASH

PRESS '+' 4 TIMES

```

PAGE 1: VEHICLE OVERLAP 'F' SETTINGS
PHASE: |12345678910111213141516
VEH OVL PARENTS: | XX
VEH OVL NOT VEH: |
VEH OVL NOT PED: |
VEH OVL GRN EXT: |
STARTUP COLOR: - RED - YELLOW - GREEN
FLASH COLORS: - RED - YELLOW - GREEN
SELECT VEHICLE OVERLAP OPTIONS: (Y/N)
FLASH YELLOW IN CONTROLLER FLASH?...N
GREEN EXTENSION (0-255 SEC)...0.0
YELLOW CLEAR (0=PARENT,3-25.5 SEC)...0.0
RED CLEAR (0=PARENT,0.1-25.5 SEC)...0.0
OUTPUT AS PHASE # (0=NONE, 1-16)...0
    
```

OVERLAP PROGRAMMING COMPLETE

FLASHER CIRCUIT MODIFICATION DETAIL

IN ORDER TO INSURE THAT SIGNALS FLASH CONCURRENTLY ON THE SAME APPROACH, MAKE THE FOLLOWING FLASHER CIRCUIT CHANGES:

- ON REAR OF PDA - REMOVE WIRE FROM TERM. T2-4 AND TERMINATE ON T2-2.
- ON REAR OF PDA - REMOVE WIRE FROM TERM. T2-5 AND TERMINATE ON T2-3.
- REMOVE FLASHER UNIT 2.

THE CHANGES LISTED ABOVE TIES ALL PHASES AND OVERLAPS TO FLASHER UNIT 1.

New Installation - Temporary Design 1 (TMP Phase II) - Sheet 2 of 3

	ELECTRICAL AND PROGRAMMING DETAILS FOR:		NC 49 (Virgilina Road) at SR 1532 (Thaxton Road)		SEAL NORTH CAROLINA PROFESSIONAL ENGINEER SEAL 008453 JOHN T. ROWE, JR.
	Prepared In the Offices of:		Division 5 Person County Roxboro		
DESIGNED: October 2012 SEALED: 11/26/12 REVISED: N/A		PLAN DATE: November 2012	REVIEWED BY: JTR	PREPARED BY: S. Armstrong	REVIEWED BY:
750 N. Greenfield Pkwy, Garner, NC 27529		REVISIONS	INIT.	DATE	SIGNATURE DATE 11-29-12
				SIG. INVENTORY NO. 05-2457T1	

**OUTPUT REMAPPING ASSIGNMENT PROGRAMMING DETAIL
TO ASSIGN LOADSWITCH AUX S6 TO OVERLAP 'F'
(FOR SIGNAL HEADS 32 & 33)**

(program controller as shown below)

FROM MAIN MENU PRESS '6' (OUTPUTS), THEN
'1' (OUTPUT ASSIGNMENTS).
WITH CURSOR IN "OUTPUT ASSIGNMENT#" POSITION, ENTER "37"

DISPLAY WILL NOW SHOW THE SPECIFIED OUTPUT
ASSIGNED AS 'VEHICLE OVERLAP' AS SHOWN BELOW.

STEP 1

```

PAGE:1 C1 PIN:83 NOT ENABLED
OUTPUT ASSIGNMENT #.....37
FREQUENCY (0=DEFAULT) (0-25.5 HZ)...0.0
DUTY CYCLE (0=DEFAULT) (0 - 100%)...0
MODE (0=SOLID,1=FLASH)...0
SELECT ASSIGNMENT:
NOT ENABLED.....Y
VEHICLE PHASE.....
PEDESTRIAN PHASE.....
VEHICLE OVERLAP.....Y
PEDESTRIAN OVERLAP.....
WATCHDOG.....
DETECTOR RESET.....
ADVANCE BEACON.....
OUT OF PHASE FLASHER.....
CONTROLLER FLASH.....
RUN FREE.....
RESERVED.....
PREEMPT.....
SOFT PREEMPT.....
ANY PREEMPT.....
COORDINATION PLAN.....
OFFSET.....
PHASE CHECK.....
PHASE ON.....
PHASE NEXT.....
    
```

OVERLAP 'F' RED

THE OUTPUT IS SET AS NOT ENABLED BY DEFAULT. THIS
"Y" WILL REMAIN UNTIL THE OUTPUT IS CHANGED.
ENTER A "Y" FOR VEHICLE OVERLAP.

```

PAGE:1 C1 PIN:83 NOT ENABLED
SELECT VEHICLE OVERLAP (A=1,P=16)...6
SELECT COLOR(0=RED,1=YEL,2=GRN)...0
    
```

WHEN A 'Y' IS ENTERED FOR 'VEHICLE OVERLAP'
THE SCREEN SHOWN ABOVE WILL APPEAR.
ENTER DATA AS SHOWN.
PRESS THE 'ENT' KEY AFTER INPUTTING DATA,
THEN 'ESC'.

```

PAGE:1 C1 PIN:83 VEHICLE OVERLAP
OUTPUT ASSIGNMENT #.....37
FREQUENCY (0=DEFAULT) (0-25.5 HZ)...0.0
DUTY CYCLE (0=DEFAULT) (0 - 100%)...0
MODE (0=SOLID,1=FLASH)...0
SELECT ASSIGNMENT:
NOT ENABLED.....Y
VEHICLE PHASE.....
PEDESTRIAN PHASE.....
VEHICLE OVERLAP.....Y
PEDESTRIAN OVERLAP.....
WATCHDOG.....
DETECTOR RESET.....
ADVANCE BEACON.....
OUT OF PHASE FLASHER.....
CONTROLLER FLASH.....
RUN FREE.....
RESERVED.....
PREEMPT.....
SOFT PREEMPT.....
ANY PREEMPT.....
COORDINATION PLAN.....
OFFSET.....
PHASE CHECK.....
PHASE ON.....
PHASE NEXT.....
    
```

PRESS "+" KEY FOR OUTPUT 38

DISPLAY WILL NOW SHOW THE SPECIFIED OUTPUT
ASSIGNED AS 'VEHICLE OVERLAP' AS SHOWN BELOW.

STEP 2

```

PAGE:1 C1 PIN:84 NOT ENABLED
OUTPUT ASSIGNMENT #.....38
FREQUENCY (0=DEFAULT) (0-25.5 HZ)...0.0
DUTY CYCLE (0=DEFAULT) (0 - 100%)...0
MODE (0=SOLID,1=FLASH)...0
SELECT ASSIGNMENT:
NOT ENABLED.....Y
VEHICLE PHASE.....
PEDESTRIAN PHASE.....
VEHICLE OVERLAP.....Y
PEDESTRIAN OVERLAP.....
WATCHDOG.....
DETECTOR RESET.....
ADVANCE BEACON.....
OUT OF PHASE FLASHER.....
CONTROLLER FLASH.....
RUN FREE.....
RESERVED.....
PREEMPT.....
SOFT PREEMPT.....
ANY PREEMPT.....
COORDINATION PLAN.....
OFFSET.....
PHASE CHECK.....
PHASE ON.....
PHASE NEXT.....
    
```

OVERLAP 'F' GREEN

THE OUTPUT IS SET AS NOT ENABLED BY DEFAULT. THIS
"Y" WILL REMAIN UNTIL THE OUTPUT IS CHANGED.
ENTER A "Y" FOR VEHICLE OVERLAP.

```

PAGE:1 C1 PIN:84 NOT ENABLED
SELECT VEHICLE OVERLAP (A=1,P=16)...6
SELECT COLOR(0=RED,1=YEL,2=GRN)...2
    
```

WHEN A 'Y' IS ENTERED FOR 'VEHICLE OVERLAP'
THE SCREEN SHOWN ABOVE WILL APPEAR.
ENTER DATA AS SHOWN.
PRESS THE 'ENT' KEY AFTER INPUTTING DATA,
THEN 'ESC'.

```

PAGE:1 C1 PIN:84 VEHICLE OVERLAP
OUTPUT ASSIGNMENT #.....38
FREQUENCY (0=DEFAULT) (0-25.5 HZ)...0.0
DUTY CYCLE (0=DEFAULT) (0 - 100%)...0
MODE (0=SOLID,1=FLASH)...0
SELECT ASSIGNMENT:
NOT ENABLED.....Y
VEHICLE PHASE.....
PEDESTRIAN PHASE.....
VEHICLE OVERLAP.....Y
PEDESTRIAN OVERLAP.....
WATCHDOG.....
DETECTOR RESET.....
ADVANCE BEACON.....
OUT OF PHASE FLASHER.....
CONTROLLER FLASH.....
RUN FREE.....
RESERVED.....
PREEMPT.....
SOFT PREEMPT.....
ANY PREEMPT.....
COORDINATION PLAN.....
OFFSET.....
PHASE CHECK.....
PHASE ON.....
PHASE NEXT.....
    
```

PRESS "+" KEY TO ADVANCE TO OUTPUT 53

DISPLAY WILL NOW SHOW THE SPECIFIED OUTPUT
ASSIGNED AS 'VEHICLE OVERLAP' AS SHOWN BELOW.

STEP 3

```

PAGE:1 C1 PIN:100 NOT ENABLED
OUTPUT ASSIGNMENT #.....53
FREQUENCY (0=DEFAULT) (0-25.5 HZ)...0.0
DUTY CYCLE (0=DEFAULT) (0 - 100%)...0
MODE (0=SOLID,1=FLASH)...0
SELECT ASSIGNMENT:
NOT ENABLED.....Y
VEHICLE PHASE.....
PEDESTRIAN PHASE.....
VEHICLE OVERLAP.....Y
PEDESTRIAN OVERLAP.....
WATCHDOG.....
DETECTOR RESET.....
ADVANCE BEACON.....
OUT OF PHASE FLASHER.....
CONTROLLER FLASH.....
RUN FREE.....
RESERVED.....
PREEMPT.....
SOFT PREEMPT.....
ANY PREEMPT.....
COORDINATION PLAN.....
OFFSET.....
PHASE CHECK.....
PHASE ON.....
PHASE NEXT.....
    
```

OVERLAP 'F' YELLOW

THE OUTPUT IS SET AS NOT ENABLED BY DEFAULT. THIS
"Y" WILL REMAIN UNTIL THE OUTPUT IS CHANGED.
ENTER A "Y" FOR VEHICLE OVERLAP.

```

PAGE:1 C1 PIN:100 CONTROLLER FLASH
SELECT VEHICLE OVERLAP (A=1,P=16)...6
SELECT COLOR(0=RED,1=YEL,2=GRN)...1
    
```

WHEN A 'Y' IS ENTERED FOR 'VEHICLE OVERLAP'
THE SCREEN SHOWN ABOVE WILL APPEAR.
ENTER DATA AS SHOWN.
PRESS THE 'ENT' KEY AFTER INPUTTING DATA,
THEN 'ESC'.

```

PAGE:1 C1 PIN:100 VEHICLE OVERLAP
OUTPUT ASSIGNMENT #.....53
FREQUENCY (0=DEFAULT) (0-25.5 HZ)...0.0
DUTY CYCLE (0=DEFAULT) (0 - 100%)...0
MODE (0=SOLID,1=FLASH)...0
SELECT ASSIGNMENT:
NOT ENABLED.....Y
VEHICLE PHASE.....
PEDESTRIAN PHASE.....
VEHICLE OVERLAP.....Y
PEDESTRIAN OVERLAP.....
WATCHDOG.....
DETECTOR RESET.....
ADVANCE BEACON.....
OUT OF PHASE FLASHER.....
CONTROLLER FLASH.....
RUN FREE.....
RESERVED.....
PREEMPT.....
SOFT PREEMPT.....
ANY PREEMPT.....
COORDINATION PLAN.....
OFFSET.....
PHASE CHECK.....
PHASE ON.....
PHASE NEXT.....
    
```

OUTPUT PROGRAMMING COMPLETE

THIS ELECTRICAL DETAIL IS FOR
THE SIGNAL DESIGN: 05-2457T1
DESIGNED: October 2012
SEALED: 11/26/12
REVISED: N/A

New Installation - Temporary Design 1 (TMP Phase II) - Sheet 3 of 3

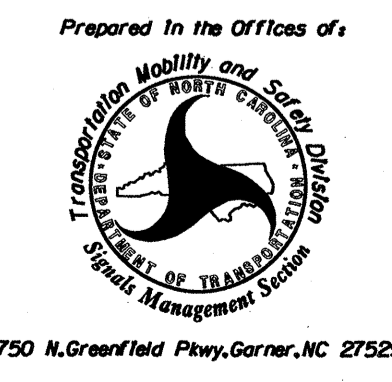
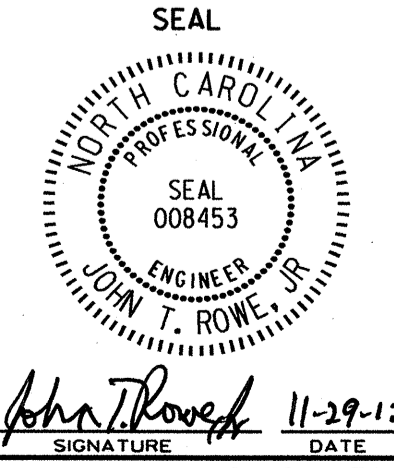
 <p>750 N. Greenfield Pkwy, Garner, NC 27529</p>	ELECTRICAL AND PROGRAMMING DETAILS FOR:		NC 49 (Virgilina Road) at SR 1532 (Thaxton Road)		
	Division 5	Person County	Roxboro	PREPARED BY: S. Armstrong	
PREPARED BY: S. Armstrong		REVIEWED BY: JTR		SIGNATURE: <i>John T. Rowe</i> DATE: 11-29-12	
REVISIONS		INIT.	DATE	SIG. INVENTORY NO. 05-2457T1	

29-NOV-2012 06:43
 S:\ITSASU\ITS Signal\Workgroups\510\Main\Armstrong\052457_sml.e.le.xxx.dgn
 sarmstrong

EDI MODEL 2018ECL-NC CONFLICT MONITOR

PROGRAMMING DETAIL

(remove jumpers and set switches as shown)

REMOVE DIODE JUMPERS 2-18, 3-8, 3-10, 3-18, 4-8, 4-10, 8-10, 8-18, and 10-18.

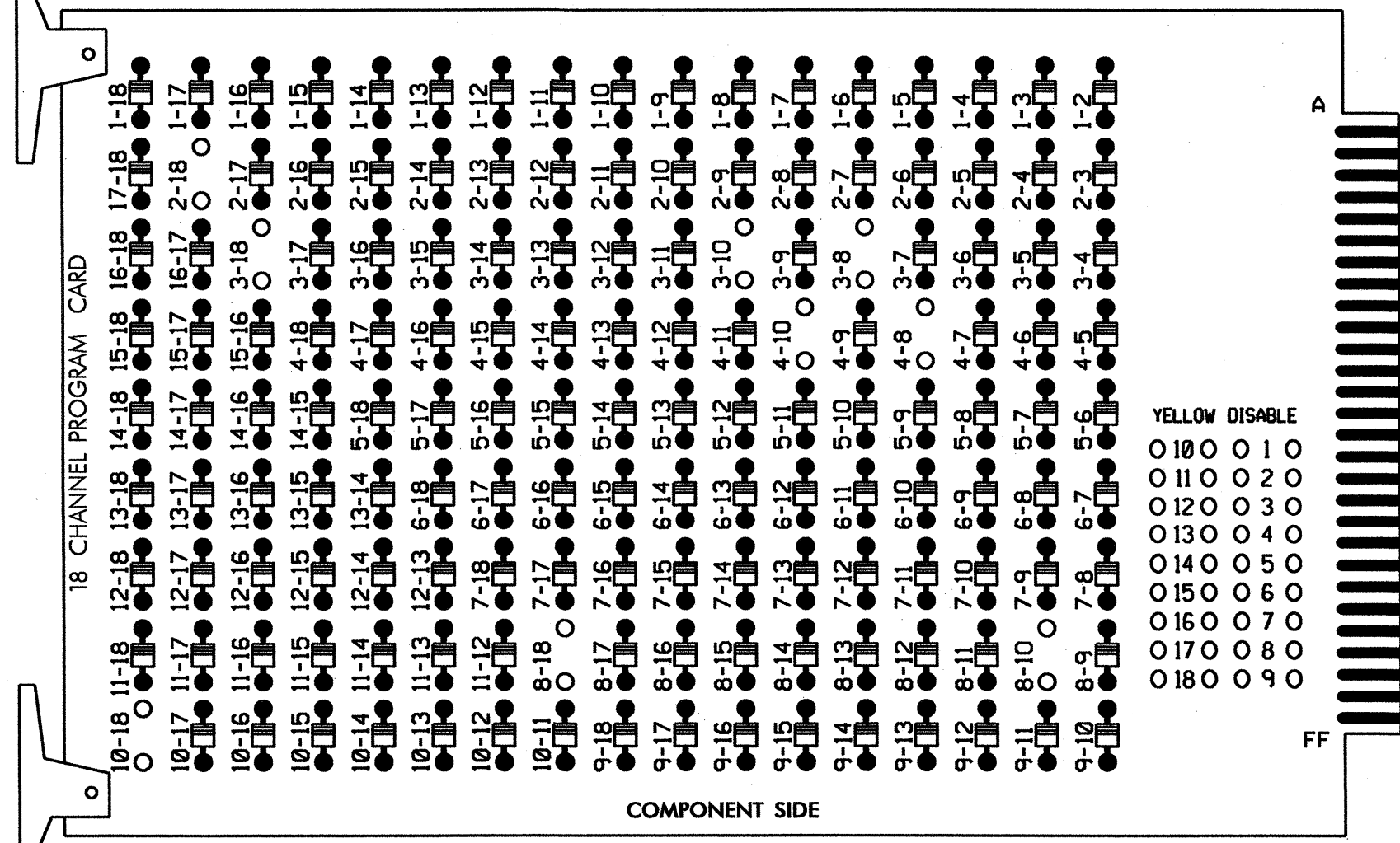

REMOVE JUMPERS AS SHOWN

NOTES:

1. Card is provided with all diode jumpers in place. Removal of any jumper allows its channels to run concurrently.
2. Ensure jumpers SEL2-SEL5 and SEL9 are present on the monitor board.
3. Ensure that Red Enable is active at all times during normal operation.
4. Connect serial cable from conflict monitor to comm. port 1 of 2070 controller. Ensure conflict monitor communicates with 2070.

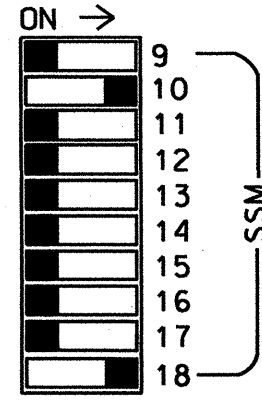
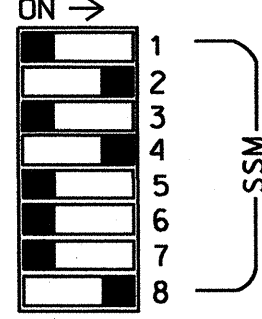
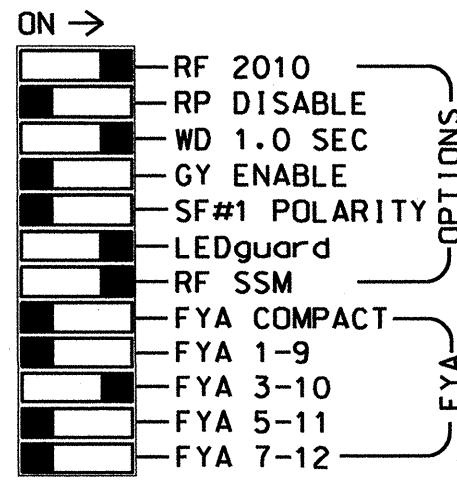
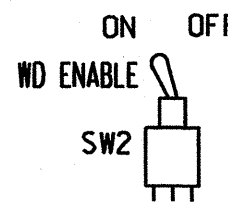

■ = DENOTES POSITION OF SWITCH

NOTES

1. To prevent "flash-conflict" problems, insert red flash program blocks for all unused vehicle load switches in the output file. The installer shall verify that signal heads flash in accordance with the Signal Plans.
2. Program phase 4 for Dual Entry.
3. Enable Simultaneous Gap-Out for all phases.
4. Program phases 4 and 8 for Start Up In Green.
5. Program phases 4 and 8 for Yellow Flash, and overlap 2 as Wag Overlaps.

EQUIPMENT INFORMATION

CONTROLLER.....2070L
 CABINET.....332 W/ AUX
 SOFTWARE.....ECONOLITE OASIS
 CABINET MOUNT.....BASE
 OUTPUT FILE POSITIONS...18 WITH AUX. OUTPUT FILE
 LOAD SWITCHES USED.....S2,S4,S5,S11,AUX S2,AUX S6
 PHASES USED.....2,3,4,8
 OVERLAP "A".....NOT USED
 OVERLAP "B".....3+4
 OVERLAP "C".....NOT USED
 OVERLAP "D".....NOT USED
 OVERLAP "E".....NOT USED
 OVERLAP "F".....2+3

SIGNAL HEAD HOOK-UP CHART

LOAD SWITCH NO.	S1	S2	S3	S4	S5	S6	S7	S8	S9	S10	S11	S12	AUX S1	AUX S2	AUX S3	AUX S4	AUX S5	AUX S6
CMU CHANNEL NO.	1	2	13	3	4	14	5	6	15	7	8	16	9	10	17	11	12	18
PHASE	1	2	2 PED	3	4	4 PED	5	6	6 PED	7	8	8 PED	OLA	OLB	SPARE	OLC	OLD	OLF
SIGNAL HEAD NO.	NU	21	NU	31	42,43,44	NU	NU	NU	NU	NU	81,82,83	NU	NU	31	NU	NU	NU	32,33
RED					101						107							A104
YELLOW				*	102						108							
GREEN					103						109							
RED ARROW		128												A124				
YELLOW ARROW		129												A125				A105
FLASHING YELLOW ARROW														A126				
GREEN ARROW	130				118													A106

NU = Not Used
 * Denotes install load resistor. See load resistor installation detail this sheet.
 * See pictorial of head wiring in detail below.
 NOTE: Outputs for loadswitch AUX S6 must be remapped. See sheet 3.

INPUT FILE POSITION LAYOUT

(front view)

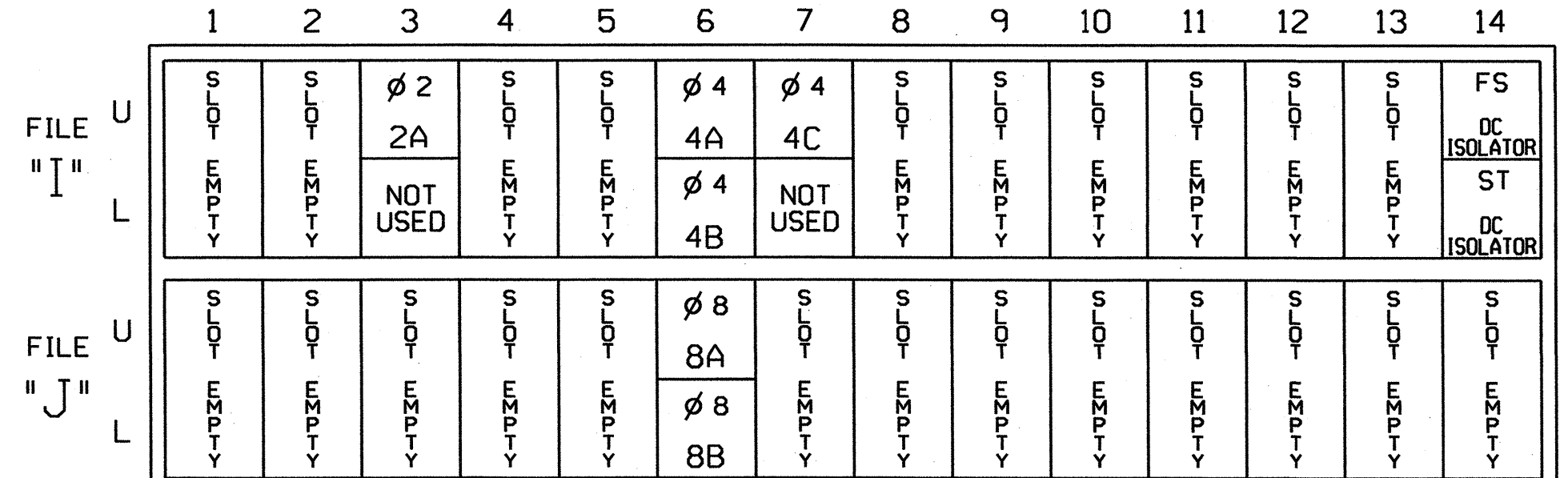

EX.: 1A, 2A, ETC. = LOOP NO.'S

FS = FLASH SENSE
 ST = STOP TIME

INPUT FILE CONNECTION & PROGRAMMING CHART

LOOP NO.	LOOP TERMINAL	INPUT FILE POS.	PIN NO.	INPUT ASSIGNMENT NO.	DETECTOR NO.	NEMA PHASE	CALL	EXTEND	FULL TIME DELAY	STRETCH TIME	DELAY TIME
2A	TB2-9,10	I3U	63	25	32	2	Y	Y			
4A	TB4-9,10	I6U	41	3	4	4		Y		2.5	
4B	TB4-11,12	I6L	45	7	14	4	Y	Y			10
4C	TB6-1,2	I7U	65	27	34	4	Y	Y			15
8A	TB5-9,10	J6U	42	4	8	8		Y		2.5	
8B	TB5-11,12	J6L	46	8	18	8	Y	Y			

INPUT FILE POSITION LEGEND: J2L

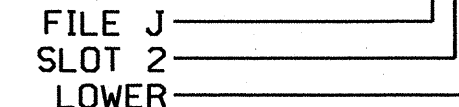

FYA SIGNAL WIRING DETAIL

(wire signal head as shown)

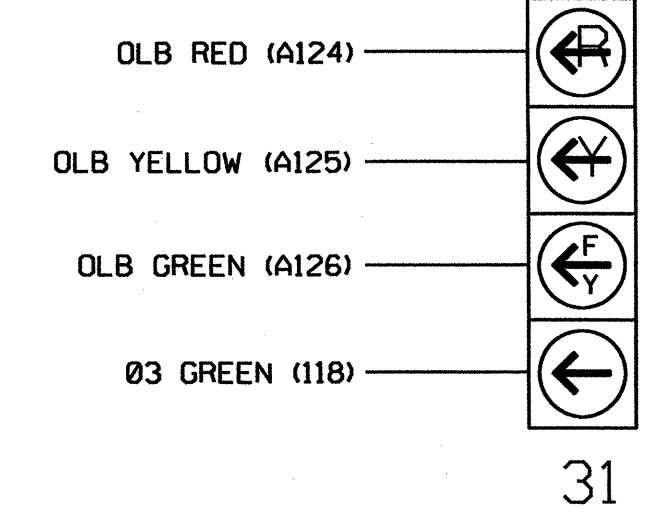

NOTE
 The sequence display for signal head 31 requires special logic programming. See sheet 2 for programming instructions.

LOAD RESISTOR INSTALLATION DETAIL

(install resistor as shown below)

VALUE (ohms)	WATTAGE
1.5K - 1.9K	25W (min)
2.0K - 3.0K	10W (min)

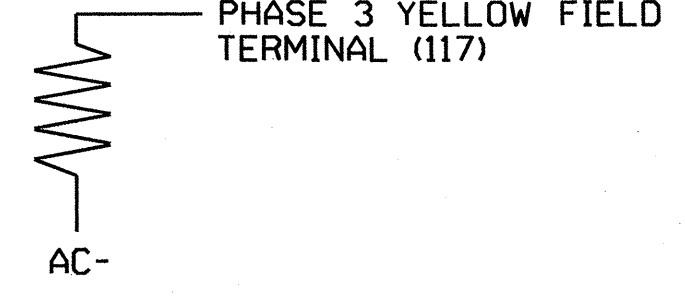

New Installation - Temporary Design 2 (TMP Phase IV) - Sheet 1 of 3

ELECTRICAL AND PROGRAMMING DETAILS FOR: 	NC 49 (Virgilina Road) at SR 1532 (Thaxton Road)		SEAL
	Division 5 PLAN DATE: November 2012 PREPARED BY: S. Armstrong	Person County REVIEWED BY: JTR REVIEWED BY:	
REVISIONS		INIT.	DATE
SIGNATURE: <i>John T. Rowe</i>		DATE: 11-29-12	SEAL:
750 N. Greenfield Pkwy, Garner, NC 27529		SIG. INVENTORY NO. 05-2457T2	

29-NOV-2012 06:48 S:\TSS\SM\TSS\SIGNAL\WORK\KOR\cuppe\sig_Man\Armstrong\052457T2_sml_e-xxx.dgn sarminstron

LOGICAL I/O PROCESSOR PROGRAMMING DETAIL TO PRODUCE SPECIAL FYA-PPLT SIGNAL SEQUENCE

(program controller as shown below)

1. FROM MAIN MENU PRESS '2' (PHASE CONTROL), THEN '1' (PHASE CONTROL FUNCTIONS), SCROLL TO THE BOTTOM OF THE MENU AND ENABLE ACT LOGIC COMMANDS 1, 2, AND 3.
2. FROM MAIN MENU PRESS '6' (OUTPUTS), THEN '3' (LOGICAL I/O PROCESSOR).

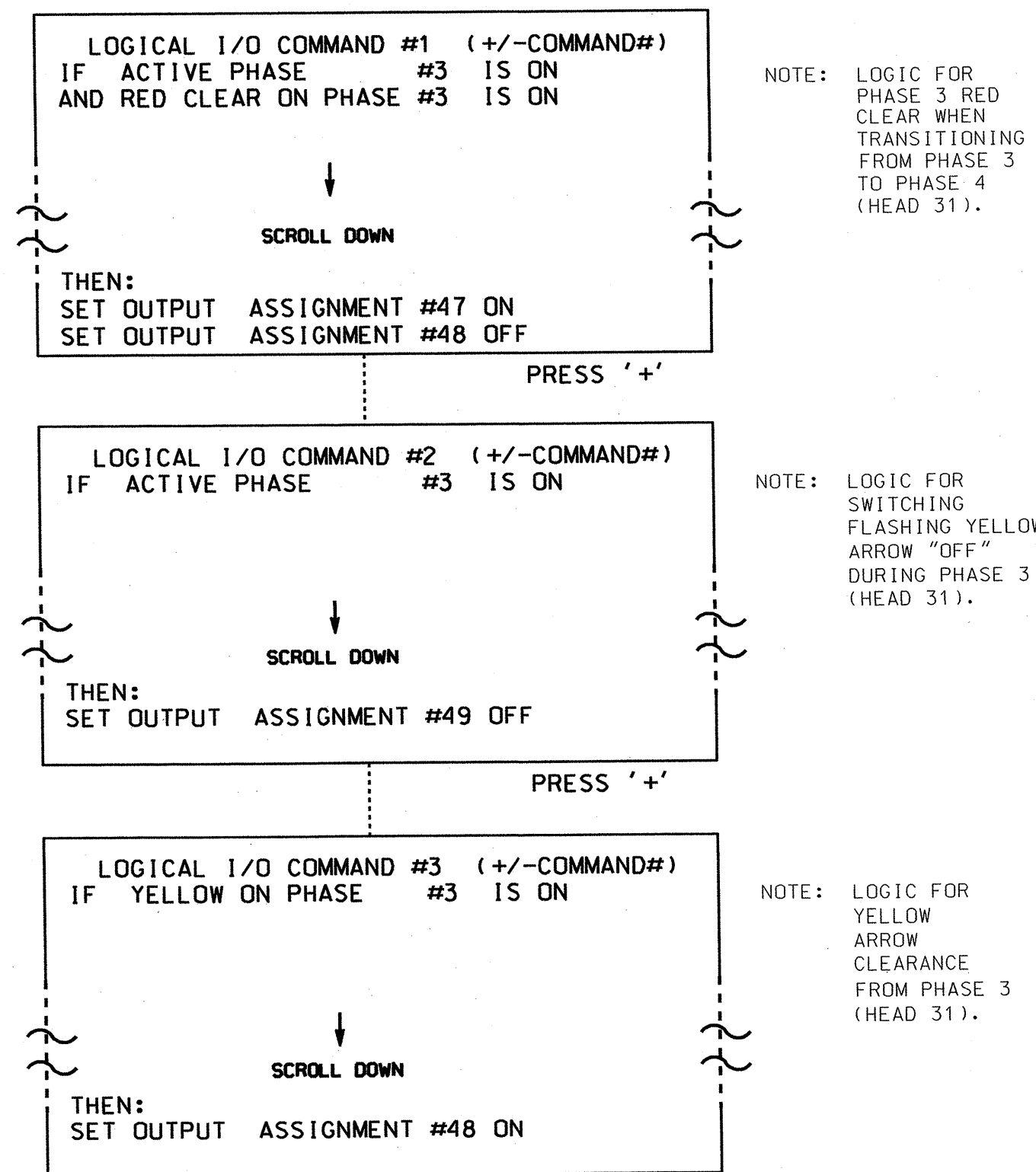

LOGIC I/O PROCESSOR PROGRAMMING COMPLETE

OUTPUT REFERENCE SCHEDULE

OUTPUT 47 = Overlap B Red
OUTPUT 48 = Overlap B Yellow
OUTPUT 49 = Overlap B Green

THIS ELECTRICAL DETAIL IS FOR
THE SIGNAL DESIGN: 05-2457T2
DESIGNED: October 2012
SEALED: 11/26/12
REVISED: N/A

OVERLAP PROGRAMMING DETAIL

(program controller as shown below)

FROM MAIN MENU PRESS '8' (OVERLAPS), THEN
'1' (VEHICLE OVERLAP SETTINGS).

PRESS '+' ONCE

```

PAGE 1: VEHICLE OVERLAP 'B' SETTINGS
PHASE: 12345678910111213141516
VEH OVL PARENTS: XX
VEH OVL NOT VEH:
VEH OVL NOT PED:
VEH OVL GRN EXT:
STARTUP COLOR: - RED - YELLOW - GREEN
FLASH COLORS: - RED - YELLOW X GREEN
SELECT VEHICLE OVERLAP OPTIONS: (Y/N)
FLASH YELLOW IN CONTROLLER FLASH?...Y
GREEN EXTENSION (0-255 SEC)...0
YELLOW CLEAR (0=PARENT.3-25.5 SEC)...0.0
RED CLEAR (0=PARENT.0.1-25.5 SEC)...0.0
OUTPUT AS PHASE # (0=NONE, 1-16)...0
  
```

← NOTICE GREEN FLASH

PRESS '+' 4 TIMES

```

PAGE 1: VEHICLE OVERLAP 'F' SETTINGS
PHASE: 12345678910111213141516
VEH OVL PARENTS: XX
VEH OVL NOT VEH:
VEH OVL NOT PED:
VEH OVL GRN EXT:
STARTUP COLOR: - RED - YELLOW - GREEN
FLASH COLORS: - RED - YELLOW - GREEN
SELECT VEHICLE OVERLAP OPTIONS: (Y/N)
FLASH YELLOW IN CONTROLLER FLASH?...N
GREEN EXTENSION (0-255 SEC)...0
YELLOW CLEAR (0=PARENT.3-25.5 SEC)...0.0
RED CLEAR (0=PARENT.0.1-25.5 SEC)...0.0
OUTPUT AS PHASE # (0=NONE, 1-16)...0
  
```

OVERLAP PROGRAMMING COMPLETE

FLASHER CIRCUIT MODIFICATION DETAIL

IN ORDER TO INSURE THAT SIGNALS FLASH CONCURRENTLY ON THE
SAME APPROACH, MAKE THE FOLLOWING FLASHER CIRCUIT CHANGES:

1. ON REAR OF PDA - REMOVE WIRE FROM TERM. T2-4 AND TERMINATE ON T2-2.
2. ON REAR OF PDA - REMOVE WIRE FROM TERM. T2-5 AND TERMINATE ON T2-3.
3. REMOVE FLASHER UNIT 2.

THE CHANGES LISTED ABOVE TIES ALL PHASES AND OVERLAPS TO FLASHER UNIT 1.

New Installation - Temporary Design 2 (TMP Phase IV) - Sheet 2 of 3

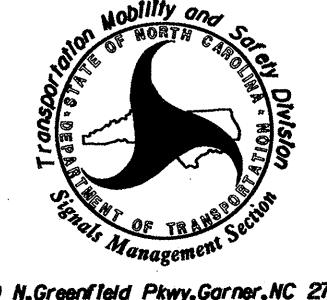
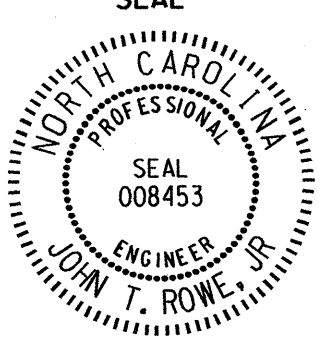
ELECTRICAL AND PROGRAMMING DETAILS FOR: Prepared In the Office of:  750 N. Greenfield Pkwy, Garner, NC 27529	NC 49 (Virgilina Road) at SR 1532 (Thaxton Road)	SEAL  JOHN T. ROWE, JR. ENGINEER
	Division 5 Person County Roxboro PLAN DATE: November 2012 REVIEWED BY: JTR PREPARED BY: S. Armstrong REVIEWED BY:	
REVISIONS _____ INIT. DATE		SIGNATURE: <i>John T. Rowe</i> DATE: 11-29-12 SIG. INVENTORY NO. 05-2457T2

**OUTPUT REMAPPING ASSIGNMENT PROGRAMMING DETAIL
TO ASSIGN LOADSWITCH AUX S6 TO OVERLAP 'F'
(FOR SIGNAL HEADS 32 & 33)**

(program controller as shown below)

FROM MAIN MENU PRESS '6' (OUTPUTS), THEN '1' (OUTPUT ASSIGNMENTS). WITH CURSOR IN "OUTPUT ASSIGNMENT#" POSITION, ENTER "37"

DISPLAY WILL NOW SHOW THE SPECIFIED OUTPUT ASSIGNED AS 'VEHICLE OVERLAP' AS SHOWN BELOW.

STEP 1

```

PAGE:1 C1 PIN:83 NOT ENABLED
OUTPUT ASSIGNMENT #.....37
FREQUENCY (0=DEFAULT) (0-25.5 HZ)...0.0
DUTY CYCLE (0=DEFAULT) (0 - 100%)...0
MODE (0=SOLID,1=FLASH)...0
SELECT ASSIGNMENT:
NOT ENABLED.....Y
VEHICLE PHASE.....
PEDESTRIAN PHASE.....
VEHICLE OVERLAP.....Y
PEDESTRIAN OVERLAP.....
WATCHDOG.....
DETECTOR RESET.....
ADVANCE BEACON.....
OUT OF PHASE FLASHER.....
CONTROLLER FLASH.....
RUN FREE.....
RESERVED.....
PREEMPT.....
SOFT PREEMPT.....
ANY PREEMPT.....
COORDINATION PLAN.....
OFFSET.....
PHASE CHECK.....
PHASE ON.....
PHASE NEXT.....
    
```

OVERLAP 'F' RED

THE OUTPUT IS SET AS NOT ENABLED BY DEFAULT. THIS "Y" WILL REMAIN UNTIL THE OUTPUT IS CHANGED.
ENTER A "Y" FOR VEHICLE OVERLAP.

```

PAGE:1 C1 PIN:83 NOT ENABLED
SELECT VEHICLE OVERLAP (A=1,P=16)...6
SELECT COLOR(0=RED,1=YEL,2=GRN)...0
    
```

WHEN A 'Y' IS ENTERED FOR 'VEHICLE OVERLAP' THE SCREEN SHOWN ABOVE WILL APPEAR. ENTER DATA AS SHOWN.
PRESS THE 'ENT' KEY AFTER INPUTTING DATA. THEN 'ESC'.

```

PAGE:1 C1 PIN:83 VEHICLE OVERLAP
OUTPUT ASSIGNMENT #.....37
FREQUENCY (0=DEFAULT) (0-25.5 HZ)...0.0
DUTY CYCLE (0=DEFAULT) (0 - 100%)...0
MODE (0=SOLID,1=FLASH)...0
SELECT ASSIGNMENT:
NOT ENABLED.....
VEHICLE PHASE.....
PEDESTRIAN PHASE.....
VEHICLE OVERLAP.....Y
PEDESTRIAN OVERLAP.....
WATCHDOG.....
DETECTOR RESET.....
ADVANCE BEACON.....
OUT OF PHASE FLASHER.....
CONTROLLER FLASH.....
RUN FREE.....
RESERVED.....
PREEMPT.....
SOFT PREEMPT.....
ANY PREEMPT.....
COORDINATION PLAN.....
OFFSET.....
PHASE CHECK.....
PHASE ON.....
PHASE NEXT.....
    
```

PRESS "+" KEY FOR OUTPUT 38

DISPLAY WILL NOW SHOW THE SPECIFIED OUTPUT ASSIGNED AS 'VEHICLE OVERLAP' AS SHOWN BELOW.

STEP 2

```

PAGE:1 C1 PIN:84 NOT ENABLED
OUTPUT ASSIGNMENT #.....38
FREQUENCY (0=DEFAULT) (0-25.5 HZ)...0.0
DUTY CYCLE (0=DEFAULT) (0 - 100%)...0
MODE (0=SOLID,1=FLASH)...0
SELECT ASSIGNMENT:
NOT ENABLED.....Y
VEHICLE PHASE.....
PEDESTRIAN PHASE.....
VEHICLE OVERLAP.....Y
PEDESTRIAN OVERLAP.....
WATCHDOG.....
DETECTOR RESET.....
ADVANCE BEACON.....
OUT OF PHASE FLASHER.....
CONTROLLER FLASH.....
RUN FREE.....
RESERVED.....
PREEMPT.....
SOFT PREEMPT.....
ANY PREEMPT.....
COORDINATION PLAN.....
OFFSET.....
PHASE CHECK.....
PHASE ON.....
PHASE NEXT.....
    
```

OVERLAP 'F' GREEN

THE OUTPUT IS SET AS NOT ENABLED BY DEFAULT. THIS "Y" WILL REMAIN UNTIL THE OUTPUT IS CHANGED.
ENTER A "Y" FOR VEHICLE OVERLAP.

```

PAGE:1 C1 PIN:84 NOT ENABLED
SELECT VEHICLE OVERLAP (A=1,P=16)...6
SELECT COLOR(0=RED,1=YEL,2=GRN)...2
    
```

WHEN A 'Y' IS ENTERED FOR 'VEHICLE OVERLAP' THE SCREEN SHOWN ABOVE WILL APPEAR. ENTER DATA AS SHOWN.
PRESS THE 'ENT' KEY AFTER INPUTTING DATA. THEN 'ESC'.

```

PAGE:1 C1 PIN:84 VEHICLE OVERLAP
OUTPUT ASSIGNMENT #.....38
FREQUENCY (0=DEFAULT) (0-25.5 HZ)...0.0
DUTY CYCLE (0=DEFAULT) (0 - 100%)...0
MODE (0=SOLID,1=FLASH)...0
SELECT ASSIGNMENT:
NOT ENABLED.....
VEHICLE PHASE.....
PEDESTRIAN PHASE.....
VEHICLE OVERLAP.....Y
PEDESTRIAN OVERLAP.....
WATCHDOG.....
DETECTOR RESET.....
ADVANCE BEACON.....
OUT OF PHASE FLASHER.....
CONTROLLER FLASH.....
RUN FREE.....
RESERVED.....
PREEMPT.....
SOFT PREEMPT.....
ANY PREEMPT.....
COORDINATION PLAN.....
OFFSET.....
PHASE CHECK.....
PHASE ON.....
PHASE NEXT.....
    
```

PRESS "+" KEY TO ADVANCE TO OUTPUT 53

DISPLAY WILL NOW SHOW THE SPECIFIED OUTPUT ASSIGNED AS 'VEHICLE OVERLAP' AS SHOWN BELOW.

STEP 3

```

PAGE:1 C1 PIN:100 NOT ENABLED
OUTPUT ASSIGNMENT #.....53
FREQUENCY (0=DEFAULT) (0-25.5 HZ)...0.0
DUTY CYCLE (0=DEFAULT) (0 - 100%)...0
MODE (0=SOLID,1=FLASH)...0
SELECT ASSIGNMENT:
NOT ENABLED.....Y
VEHICLE PHASE.....
PEDESTRIAN PHASE.....
VEHICLE OVERLAP.....Y
PEDESTRIAN OVERLAP.....
WATCHDOG.....
DETECTOR RESET.....
ADVANCE BEACON.....
OUT OF PHASE FLASHER.....
CONTROLLER FLASH.....
RUN FREE.....
RESERVED.....
PREEMPT.....
SOFT PREEMPT.....
ANY PREEMPT.....
COORDINATION PLAN.....
OFFSET.....
PHASE CHECK.....
PHASE ON.....
PHASE NEXT.....
    
```

OVERLAP 'F' YELLOW

THE OUTPUT IS SET AS NOT ENABLED BY DEFAULT. THIS "Y" WILL REMAIN UNTIL THE OUTPUT IS CHANGED.
ENTER A "Y" FOR VEHICLE OVERLAP.

```

PAGE:1 C1 PIN:100 CONTROLLER FLASH
SELECT VEHICLE OVERLAP (A=1,P=16)...6
SELECT COLOR(0=RED,1=YEL,2=GRN)...1
    
```

WHEN A 'Y' IS ENTERED FOR 'VEHICLE OVERLAP' THE SCREEN SHOWN ABOVE WILL APPEAR. ENTER DATA AS SHOWN.
PRESS THE 'ENT' KEY AFTER INPUTTING DATA. THEN 'ESC'.

```

PAGE:1 C1 PIN:100 VEHICLE OVERLAP
OUTPUT ASSIGNMENT #.....53
FREQUENCY (0=DEFAULT) (0-25.5 HZ)...0.0
DUTY CYCLE (0=DEFAULT) (0 - 100%)...0
MODE (0=SOLID,1=FLASH)...0
SELECT ASSIGNMENT:
NOT ENABLED.....
VEHICLE PHASE.....
PEDESTRIAN PHASE.....
VEHICLE OVERLAP.....Y
PEDESTRIAN OVERLAP.....
WATCHDOG.....
DETECTOR RESET.....
ADVANCE BEACON.....
OUT OF PHASE FLASHER.....
CONTROLLER FLASH.....
RUN FREE.....
RESERVED.....
PREEMPT.....
SOFT PREEMPT.....
ANY PREEMPT.....
COORDINATION PLAN.....
OFFSET.....
PHASE CHECK.....
PHASE ON.....
PHASE NEXT.....
    
```

OUTPUT PROGRAMMING COMPLETE

THIS ELECTRICAL DETAIL IS FOR
THE SIGNAL DESIGN: 05-2457T2
DESIGNED: October 2012
SEALED: 11/26/12
REVISED: N/A

New Installation - Temporary Design 2 (TMP Phase IV) - Sheet 3 of 3

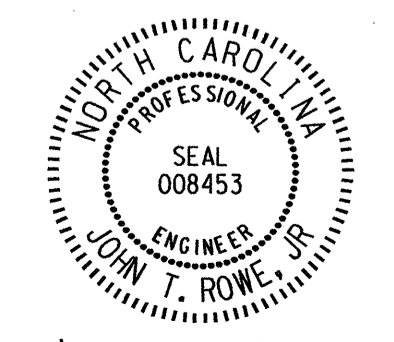
 <p>750 N. Greenfield Pkwy, Garner, NC 27529</p>	<p align="center">NC 49 (Virgilina Road) at SR 1532 (Thaxton Road)</p>		<p align="center">SEAL</p>  <p align="center">JOHN T. ROWLAND ENGINEER 008453</p>					
	<p>Division 5 Person County Roxboro</p> <p>PLAN DATE: November 2012 REVIEWED BY: JTR</p> <p>PREPARED BY: S. Armstrong REVIEWED BY:</p>	<p>REVISIONS</p> <table border="1"> <thead> <tr> <th>NO.</th> <th>INIT.</th> <th>DATE</th> </tr> </thead> <tbody> <tr> <td> </td> <td> </td> <td> </td> </tr> </tbody> </table>		NO.	INIT.	DATE		
NO.	INIT.	DATE						

LOGICAL I/O PROCESSOR PROGRAMMING DETAIL TO PRODUCE SPECIAL FYA-PPLT SIGNAL SEQUENCE

(program controller as shown below)

- FROM MAIN MENU PRESS '2' (PHASE CONTROL), THEN '1' (PHASE CONTROL FUNCTIONS), SCROLL TO THE BOTTOM OF THE MENU AND ENABLE ACT LOGIC COMMANDS 1, 2, 3, 4, 5, 6, 7, 8, AND 9.
- FROM MAIN MENU PRESS '6' (OUTPUTS), THEN '3' (LOGICAL I/O PROCESSOR).

LOGICAL I/O COMMAND #1 (+/-COMMAND#)
IF ACTIVE PHASE #1 IS ON
AND RED CLEAR ON PHASE #1 IS ON

SCROLL DOWN

THEN:
SET OUTPUT ASSIGNMENT #50 ON
SET OUTPUT ASSIGNMENT #51 OFF

PRESS '+'

NOTE: LOGIC FOR PHASE 1 RED CLEAR WHEN TRANSITIONING FROM PHASE 1 TO PHASE 2 (HEAD 11).

LOGICAL I/O COMMAND #2 (+/-COMMAND#)
IF ACTIVE PHASE #1 IS ON

SCROLL DOWN

THEN:
SET OUTPUT ASSIGNMENT #52 OFF

PRESS '+'

NOTE: LOGIC FOR SWITCHING FLASHING YELLOW ARROW "OFF" DURING PHASE 1 (HEAD 11).

LOGICAL I/O COMMAND #3 (+/-COMMAND#)
IF YELLOW ON PHASE #1 IS ON

SCROLL DOWN

THEN:
SET OUTPUT ASSIGNMENT #51 ON

PRESS '+'

NOTE: LOGIC FOR YELLOW ARROW CLEARANCE FROM PHASE 1 (HEAD 11).

LOGICAL I/O COMMAND #4 (+/-COMMAND#)
IF ACTIVE PHASE #5 IS ON
AND RED CLEAR ON PHASE #5 IS ON

SCROLL DOWN

THEN:
SET OUTPUT ASSIGNMENT #42 ON
SET OUTPUT ASSIGNMENT #43 OFF

PRESS '+'

NOTE: LOGIC FOR PHASE 5 RED CLEAR WHEN TRANSITIONING FROM PHASE 5 TO PHASE 6 (HEAD 51).

LOGICAL I/O COMMAND #5 (+/-COMMAND#)
IF ACTIVE PHASE #5 IS ON

SCROLL DOWN

THEN:
SET OUTPUT ASSIGNMENT #44 OFF

PRESS '+'

NOTE: LOGIC FOR SWITCHING FLASHING YELLOW ARROW "OFF" DURING PHASE 5 (HEAD 51).

LOGICAL I/O COMMAND #6 (+/-COMMAND#)
IF YELLOW ON PHASE #5 IS ON

SCROLL DOWN

THEN:
SET OUTPUT ASSIGNMENT #43 ON

PRESS '+'

NOTE: LOGIC FOR YELLOW ARROW CLEARANCE FROM PHASE 5 (HEAD 51).

LOGICAL I/O COMMAND #7 (+/-COMMAND#)
IF ACTIVE PHASE #3 IS ON
AND RED CLEAR ON PHASE #3 IS ON

SCROLL DOWN

THEN:
SET OUTPUT ASSIGNMENT #47 ON
SET OUTPUT ASSIGNMENT #48 OFF

PRESS '+'

NOTE: LOGIC FOR PHASE 3 RED CLEAR WHEN TRANSITIONING FROM PHASE 3 TO PHASE 4 (HEAD 31).

LOGICAL I/O COMMAND #8 (+/-COMMAND#)
IF ACTIVE PHASE #3 IS ON

SCROLL DOWN

THEN:
SET OUTPUT ASSIGNMENT #49 OFF

PRESS '+'

NOTE: LOGIC FOR SWITCHING FLASHING YELLOW ARROW "OFF" DURING PHASE 3 (HEAD 31).

LOGICAL I/O COMMAND #9 (+/-COMMAND#)
IF YELLOW ON PHASE #3 IS ON

SCROLL DOWN

THEN:
SET OUTPUT ASSIGNMENT #48 ON

PRESS '+'

NOTE: LOGIC FOR YELLOW ARROW CLEARANCE FROM PHASE 3 (HEAD 31).

LOGIC I/O PROCESSOR PROGRAMMING COMPLETE

OUTPUT REFERENCE SCHEDULE

USE TO INTERPRET LOGIC PROCESSOR

- OUTPUT 42 = Overlap C Red
- OUTPUT 43 = Overlap C Yellow
- OUTPUT 44 = Overlap C Green
- OUTPUT 47 = Overlap B Red
- OUTPUT 48 = Overlap B Yellow
- OUTPUT 49 = Overlap B Green
- OUTPUT 50 = Overlap A Red
- OUTPUT 51 = Overlap A Yellow
- OUTPUT 52 = Overlap A Green

OVERLAP PROGRAMMING DETAIL

(program controller as shown below)

FROM MAIN MENU PRESS '8' (OVERLAPS), THEN '1' (VEHICLE OVERLAP SETTINGS).

PAGE 1: VEHICLE OVERLAP 'A' SETTINGS
PHASE: 12345678910111213141516
VEH OVL PARENTS: XX
VEH OVL NOT VEH:
VEH OVL NOT PED:
VEH OVL GRN EXT:
STARTUP COLOR: - RED - YELLOW - GREEN
FLASH COLORS: - RED - YELLOW X GREEN
SELECT VEHICLE OVERLAP OPTIONS: (Y/N)
FLASH YELLOW IN CONTROLLER FLASH?...Y
GREEN EXTENSION (0-255 SEC)...0
YELLOW CLEAR (0=PARENT.3-25.5 SEC)...0.0
RED CLEAR (0=PARENT.0.1-25.5 SEC)...0.0
OUTPUT AS PHASE # (0=NONE, 1-16)...0

NOTICE GREEN FLASH

PAGE 1: VEHICLE OVERLAP 'B' SETTINGS
PHASE: 12345678910111213141516
VEH OVL PARENTS: XX
VEH OVL NOT VEH:
VEH OVL NOT PED:
VEH OVL GRN EXT:
STARTUP COLOR: - RED - YELLOW - GREEN
FLASH COLORS: - RED - YELLOW X GREEN
SELECT VEHICLE OVERLAP OPTIONS: (Y/N)
FLASH YELLOW IN CONTROLLER FLASH?...N
GREEN EXTENSION (0-255 SEC)...0
YELLOW CLEAR (0=PARENT.3-25.5 SEC)...0.0
RED CLEAR (0=PARENT.0.1-25.5 SEC)...0.0
OUTPUT AS PHASE # (0=NONE, 1-16)...0

NOTICE GREEN FLASH

PAGE 1: VEHICLE OVERLAP 'C' SETTINGS
PHASE: 12345678910111213141516
VEH OVL PARENTS: XX
VEH OVL NOT VEH:
VEH OVL NOT PED:
VEH OVL GRN EXT:
STARTUP COLOR: - RED - YELLOW - GREEN
FLASH COLORS: - RED - YELLOW X GREEN
SELECT VEHICLE OVERLAP OPTIONS: (Y/N)
FLASH YELLOW IN CONTROLLER FLASH?...Y
GREEN EXTENSION (0-255 SEC)...0
YELLOW CLEAR (0=PARENT.3-25.5 SEC)...0.0
RED CLEAR (0=PARENT.0.1-25.5 SEC)...0.0
OUTPUT AS PHASE # (0=NONE, 1-16)...0

NOTICE GREEN FLASH

PAGE 1: VEHICLE OVERLAP 'D' SETTINGS
PHASE: 12345678910111213141516
VEH OVL PARENTS: X
VEH OVL NOT VEH:
VEH OVL NOT PED:
VEH OVL GRN EXT:
STARTUP COLOR: - RED - YELLOW - GREEN
FLASH COLORS: - RED - YELLOW X GREEN
SELECT VEHICLE OVERLAP OPTIONS: (Y/N)
FLASH YELLOW IN CONTROLLER FLASH?...N
GREEN EXTENSION (0-255 SEC)...0
YELLOW CLEAR (0=PARENT.3-25.5 SEC)...0.0
RED CLEAR (0=PARENT.0.1-25.5 SEC)...0.0
OUTPUT AS PHASE # (0=NONE, 1-16)...0

NOTICE GREEN FLASH

OVERLAP PROGRAMMING COMPLETE

FLASHER CIRCUIT MODIFICATION DETAIL

IN ORDER TO INSURE THAT SIGNALS FLASH CONCURRENTLY ON THE SAME APPROACH, MAKE THE FOLLOWING FLASHER CIRCUIT CHANGES:

- ON REAR OF PDA - REMOVE WIRE FROM TERM. T2-4 AND TERMINATE ON T2-2.
- ON REAR OF PDA - REMOVE WIRE FROM TERM. T2-5 AND TERMINATE ON T2-3.
- REMOVE FLASHER UNIT 2.

THE CHANGES LISTED ABOVE TIES ALL PHASES AND OVERLAPS TO FLASHER UNIT 1.

THIS ELECTRICAL DETAIL IS FOR THE SIGNAL DESIGN: 05-2457
DESIGNED: June 2012
SEALED: 11/26/12
REVISED: N/A

Signal Upgrade - Final Design - Sheet 2 of 2

	ELECTRICIAN AND PROGRAMMING DETAILS FOR:		US 501 at NC 49 (Virgilia Road) / SR 1532 (Thaxton Road)		
	Division 5 PLAN DATE: November 2012 PREPARED BY: S. Armstrong	Person County REVIEWED BY: JTR REVIEWED BY:	Roxboro REVISIONS INIT. DATE	SIGNATURE: <i>[Signature]</i> DATE: 11-28-12 SIG. INVENTORY NO. 05-2457	

STATE OF NORTH CAROLINA
DEPT. OF TRANSPORTATION
DIVISION OF HIGHWAYS
RALEIGH, N.C.

11-08

ENGLISH DETAIL DRAWING FOR
INDUCTIVE DETECTION LOOPS

SHEET 1 OF 3
1725D01

SAW SLOT DEPTH CHART

DEPTH (IN)	NO. OF WIRE TURNS				
	2	3	4	5	6
CONCRETE	2.0	2.0	2.5	2.5	3.0
ASPHALT	2.0	2.5	3.0	3.0	3.0

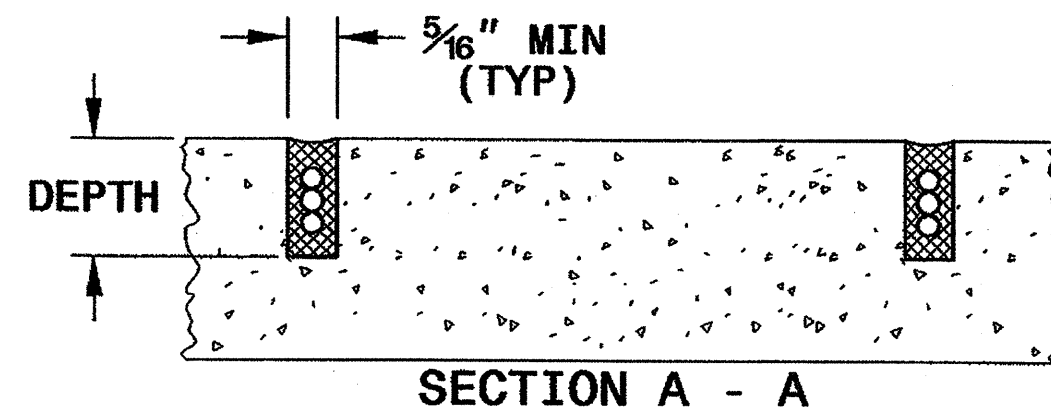

CONVENTIONAL 4-SIDED LOOP

SAW CUT OPTIONS

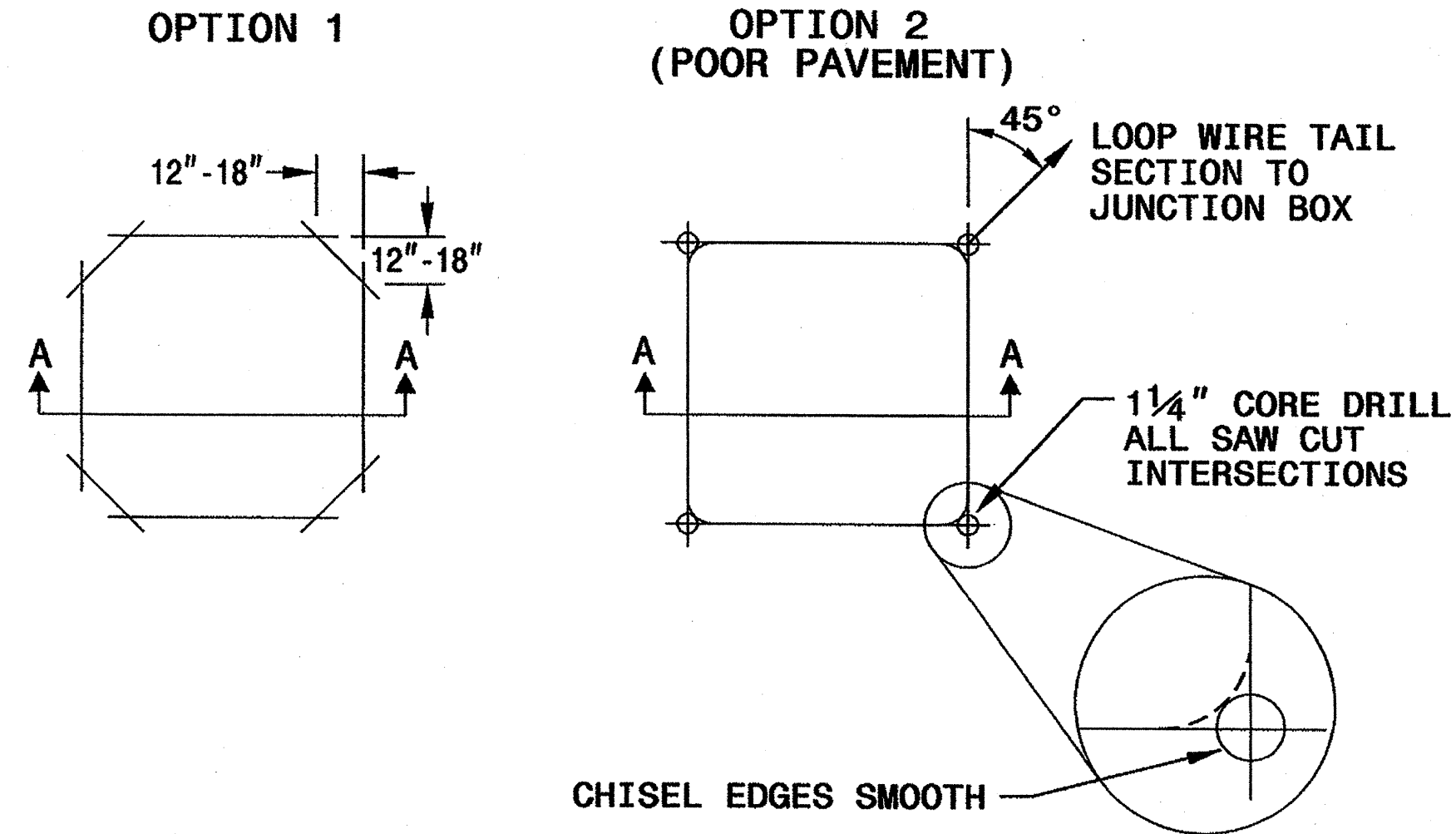

LOOP WINDING METHOD

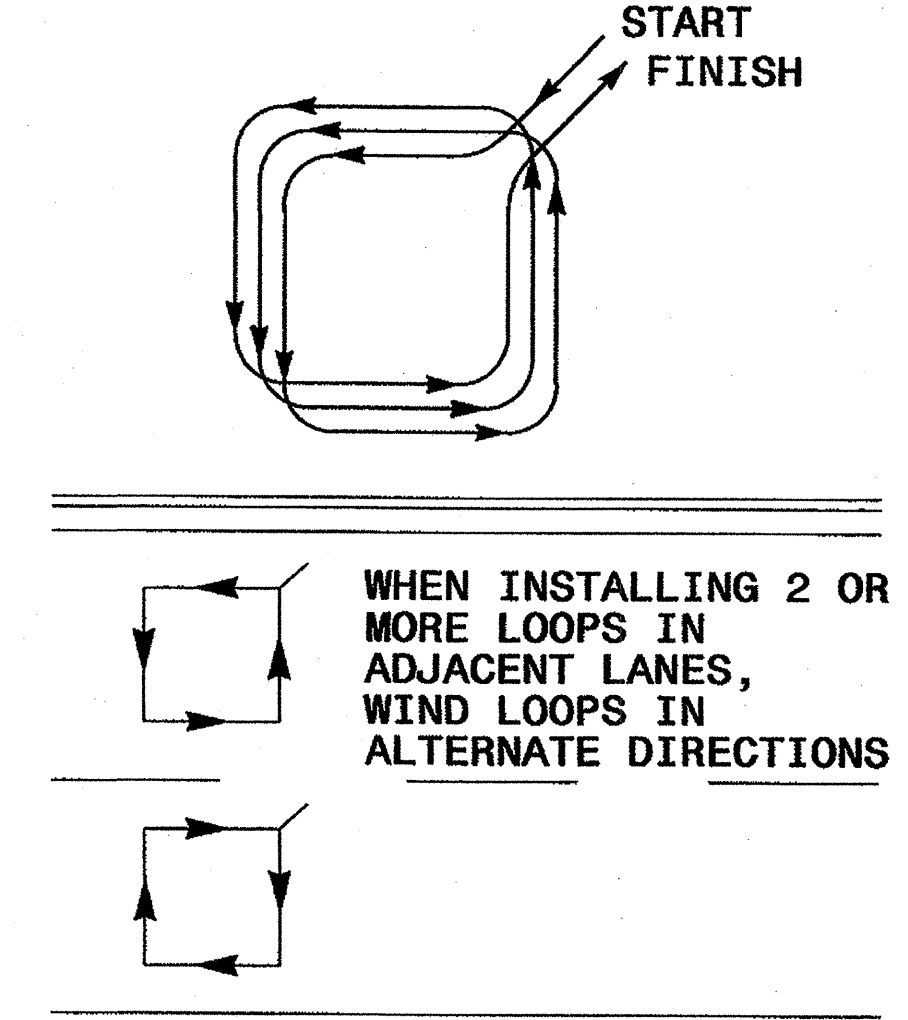

LOOP WIRE TWISTING METHOD

INCORRECT WAY TO TWIST WIRE

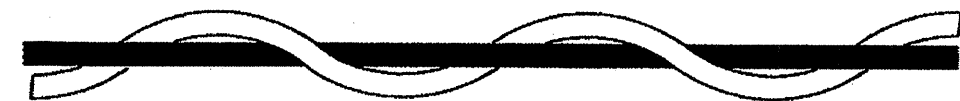

CORRECT WAY TO TWIST WIRE



NOTES

1. OVERLAP SAW CUTS AT CORNERS AND INTERSECTION POINTS TO ENSURE UNIFORM SAW SLOT DEPTH.
2. MAINTAIN 12" SPACING BETWEEN LOOP WIRE TAIL SECTIONS.
3. WIRE LOOPS CONNECTED TO THE SAME DETECTOR CHANNEL IN SERIES.
4. LOCATE LOOPS IN CENTER OF LANES UNLESS OTHERWISE SHOWN ON PLANS OR APPROVED BY ENGINEER.

QUADRUPOLE LOOP

SAW CUT OPTIONS

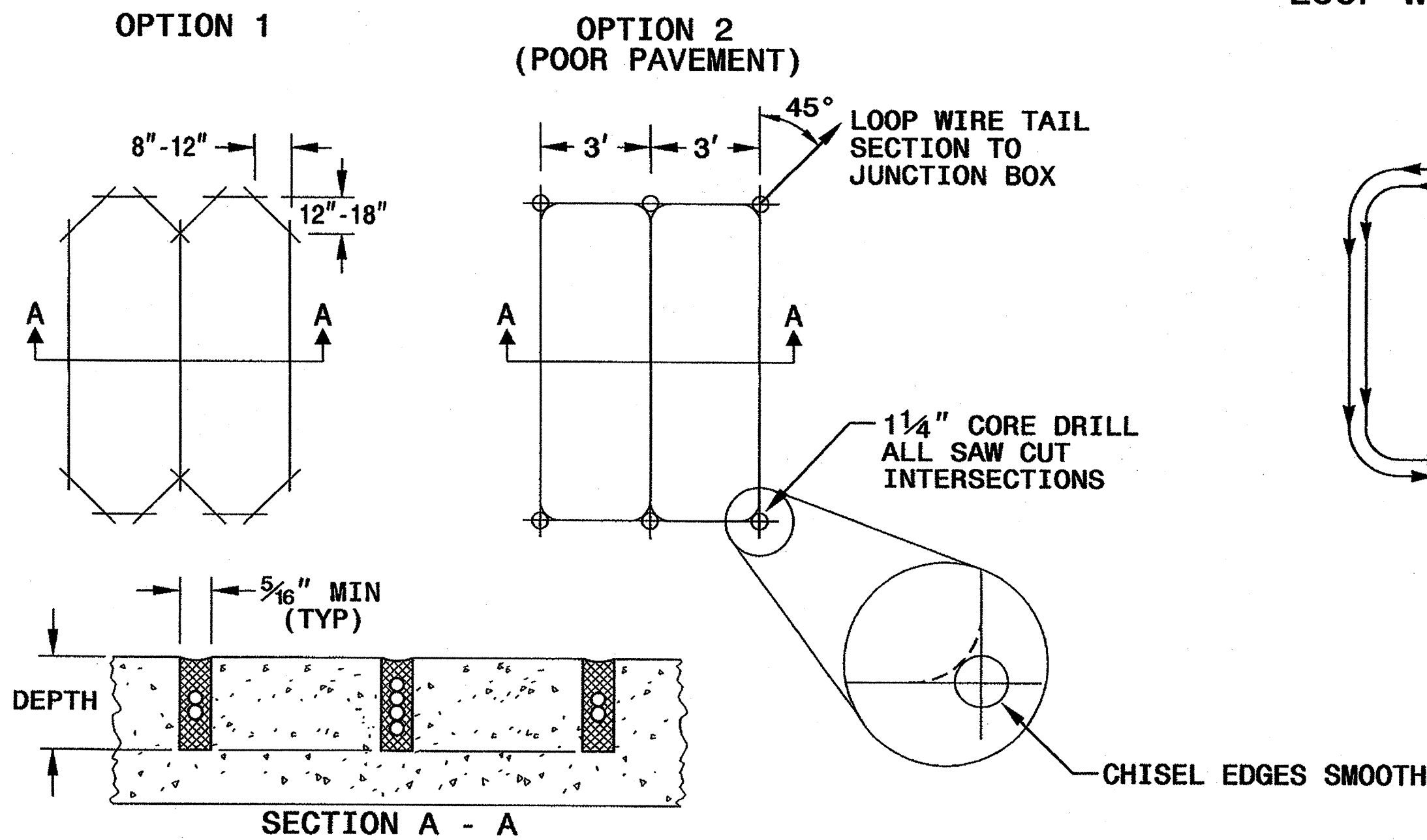

LOOP WINDING METHOD

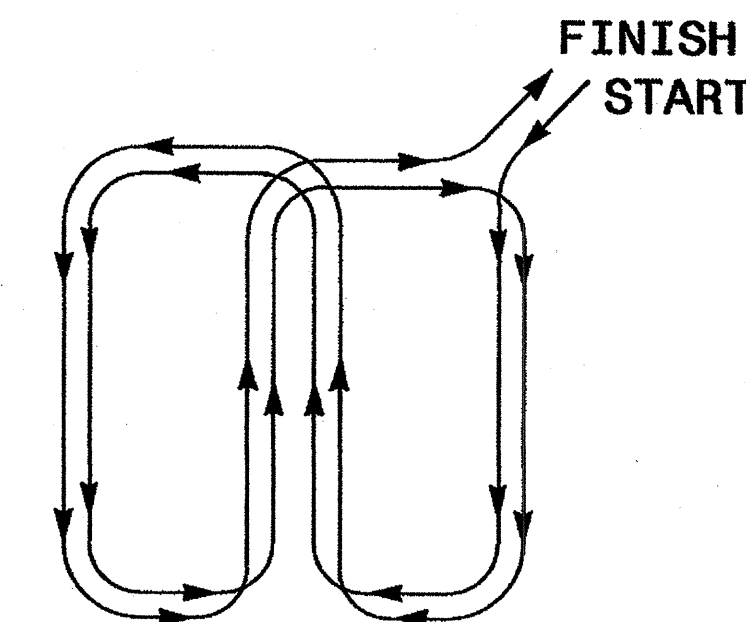

DEPTH IS 2.5" FOR CONCRETE AND 3.0" FOR ASPHALT

STATE OF NORTH CAROLINA
DEPT. OF TRANSPORTATION
DIVISION OF HIGHWAYS
RALEIGH, N.C.

11-08

ENGLISH DETAIL DRAWING FOR
INDUCTIVE DETECTION LOOPS

SHEET 1 OF 3
1725D01

See Plate for Title

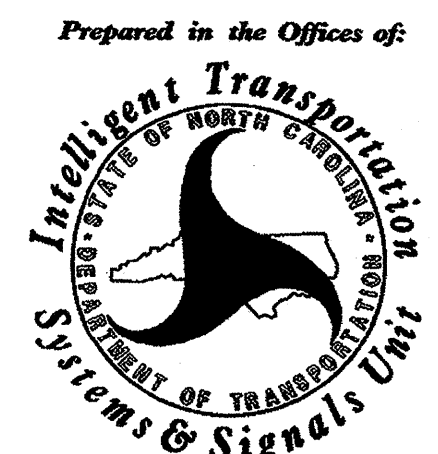

750 N. Greenfield Parkway
Garner, NC 27529

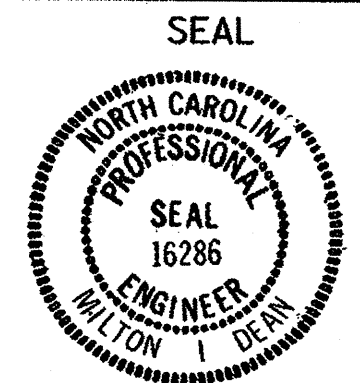

SIGNATURE DATE

STATE OF NORTH CAROLINA
DEPT. OF TRANSPORTATION
DIVISION OF HIGHWAYS
RALEIGH, N.C.

11-08

ENGLISH DETAIL DRAWING FOR
INDUCTIVE DETECTION LOOPS
LOOP WIRE DETAILS

SHEET 2 OF 3
1725D01

LOOP WIRE SPLICE POINT DETAILS

LOOP WIRE AT JUNCTION BOX

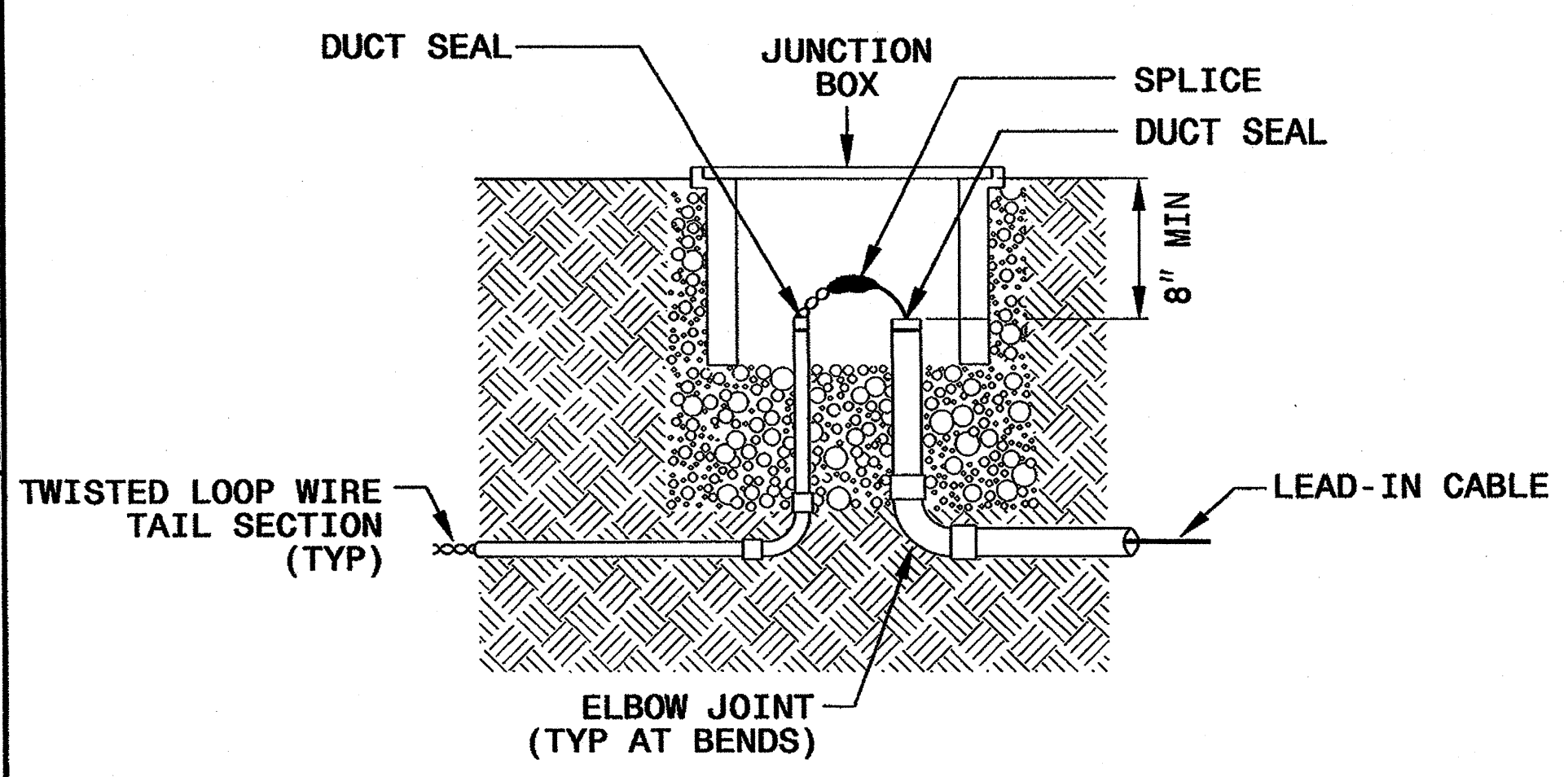

LOOP WIRE AT POLE

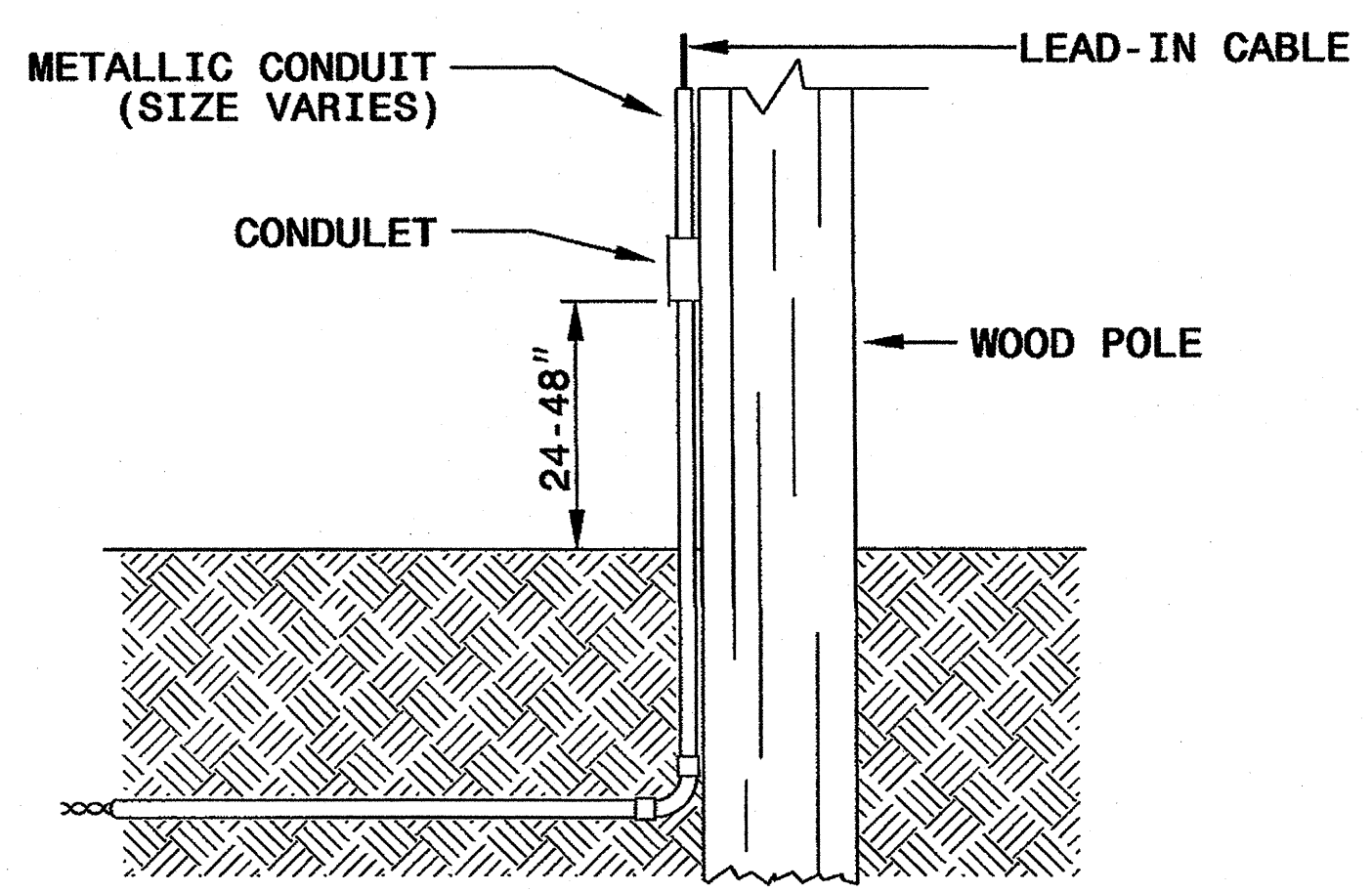

NOTE

SPLICE ALL LOOP WIRE TAIL SECTIONS/LEAD-IN CABLE IN JUNCTION BOXES OR APPROVED CONDULETS.

LOOP WIRE PAVEMENT EDGE DETAILS

LOOP WIRE AT CURB & GUTTER SECTION

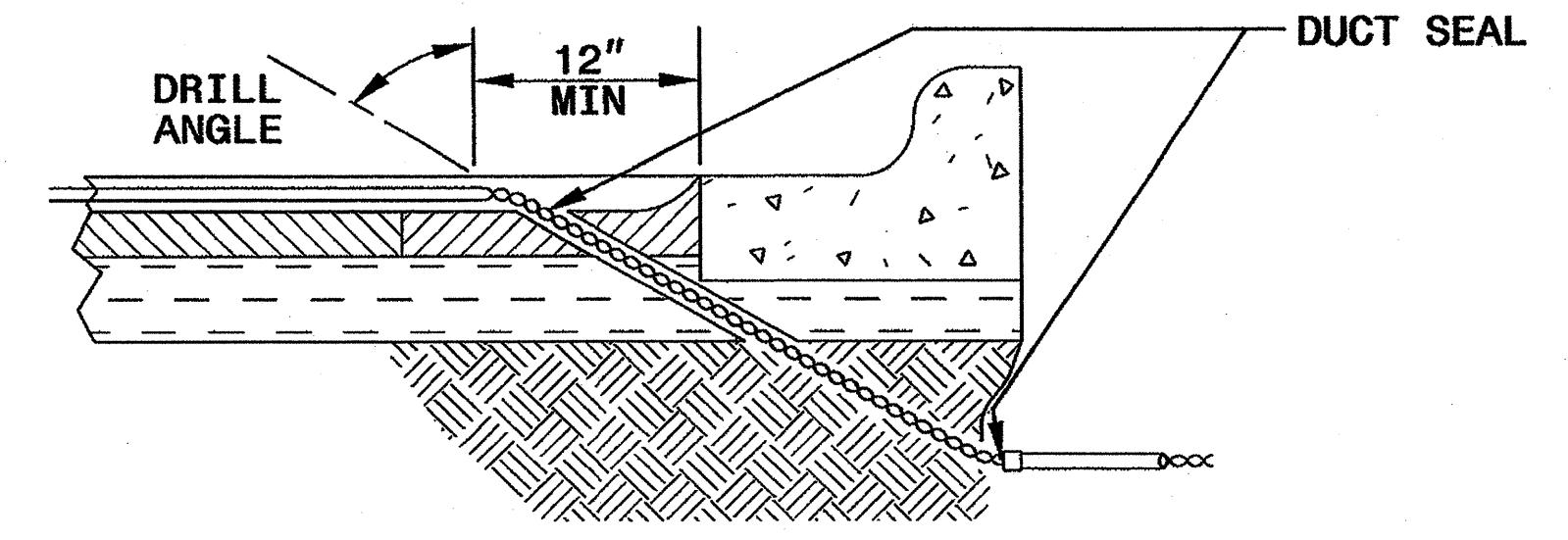

LOOP WIRE AT PAVEMENT SECTION

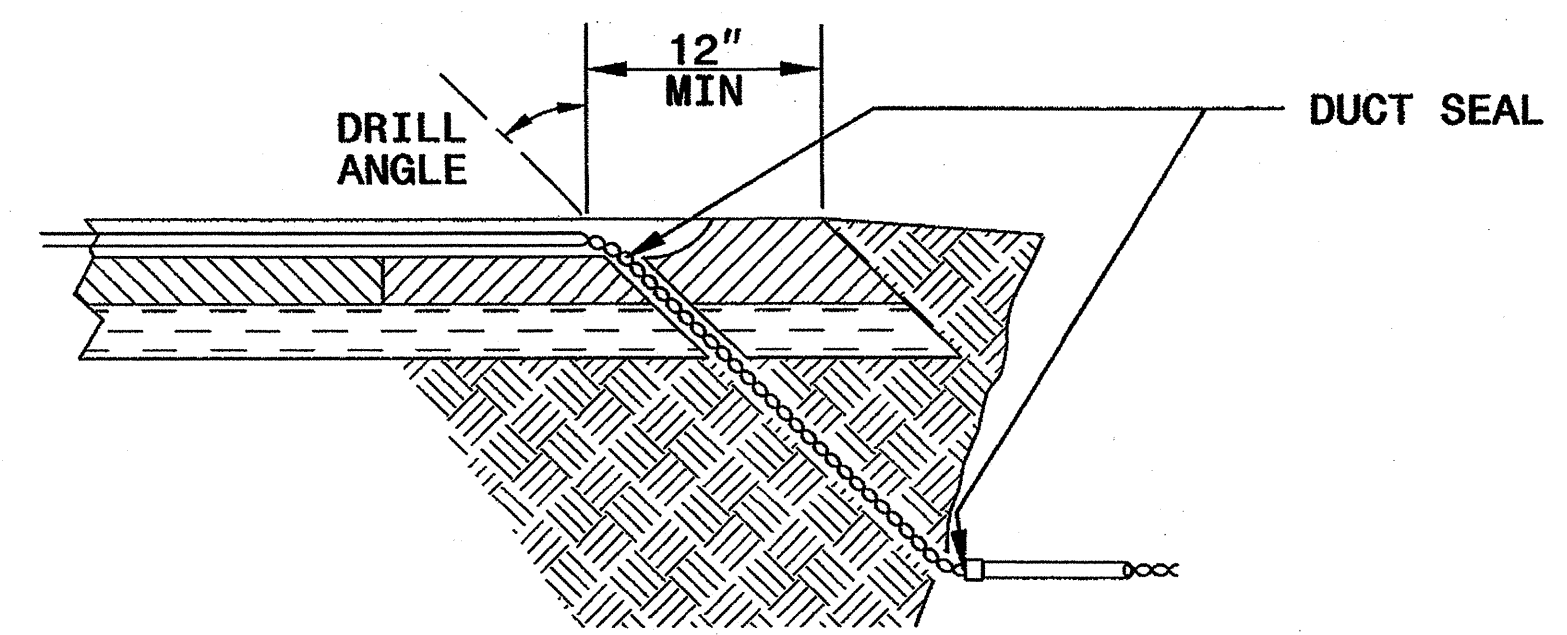

NOTES

1. DO NOT EXCAVATE UNDER CURB AND GUTTER SECTIONS FOR CONDUIT INSTALLATION.
2. TWIST LOOP WIRE TAIL SECTIONS FROM WHERE LOOP WIRE TAIL LEAVES SAW CUT TO JUNCTION BOX, INCLUDING THROUGH CONDUIT.
3. BEFORE SEALING LOOPS, INSTALL DUCT SEAL WHERE LOOP WIRE TAIL SECTION LEAVES SAW CUT IN PAVEMENT AND AT ENTRANCE OF CONDUIT TO JUNCTION BOX.

STATE OF NORTH CAROLINA
DEPT. OF TRANSPORTATION
DIVISION OF HIGHWAYS
RALEIGH, N.C.

11-08

ENGLISH DETAIL DRAWING FOR
INDUCTIVE DETECTION LOOPS
LOOP WIRE DETAILS

SHEET 2 OF 3
1725D01

See Plate for Title

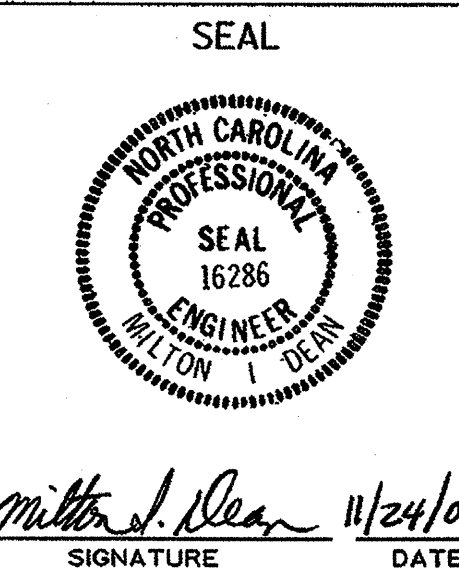
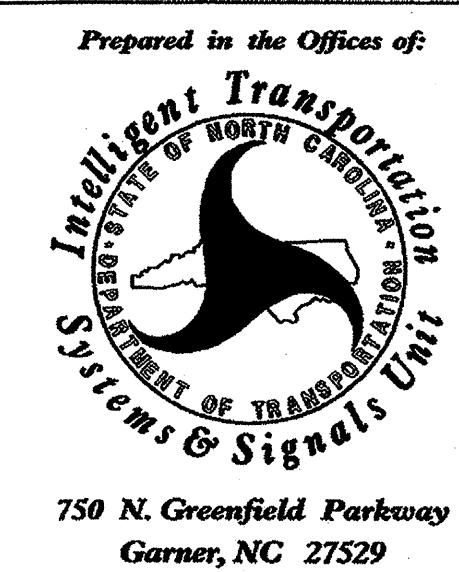

STATE OF
NORTH CAROLINA
DEPT. OF TRANSPORTATION
DIVISION OF HIGHWAYS
RALEIGH, N.C.

11-08

ENGLISH DETAIL DRAWING FOR
INDUCTIVE DETECTION LOOPS
SPlicing FOR LEAD-IN CABLE AND LOOP WIRE

SHEET 3 OF 3
1725D01

STEP 1. STRIP LOOP WIRE AND LEAD-IN CABLE

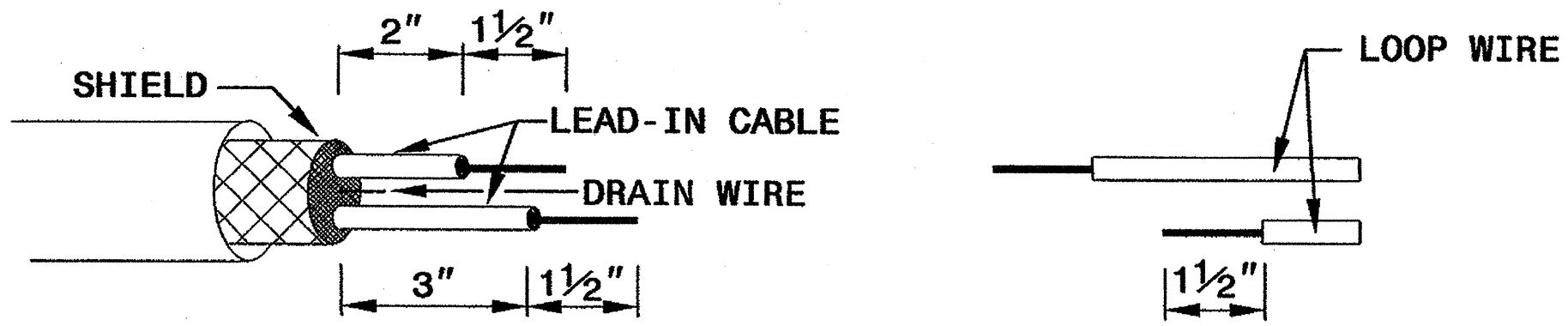

STEP 2. CONNECT AND SOLDER

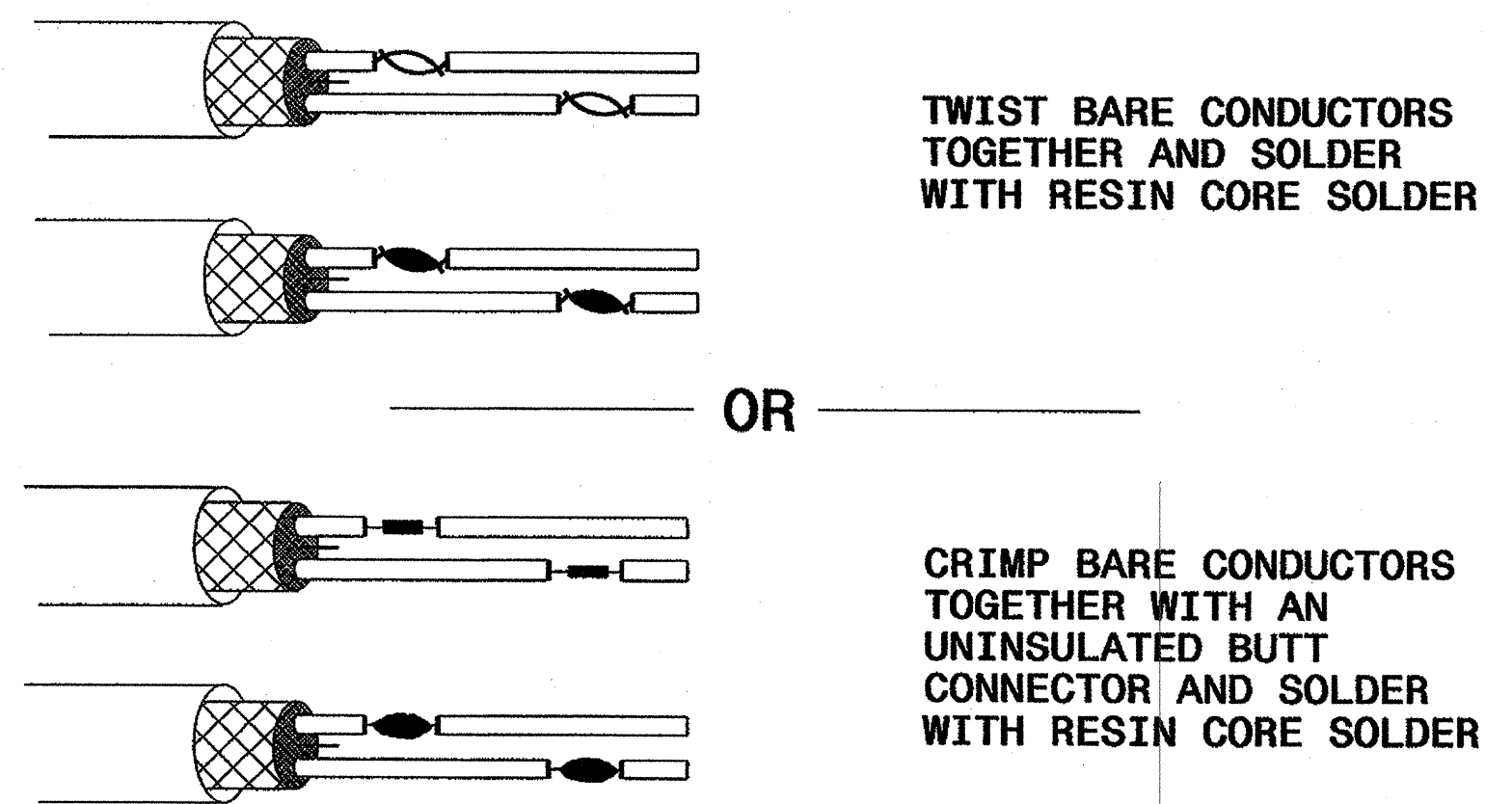

BOND SHIELD DRAIN WIRE AT SPLICE SECTIONS (DO NOT GROUND)

LOOP WIRE AND LEAD-IN CABLE CONNECTION DETAILS

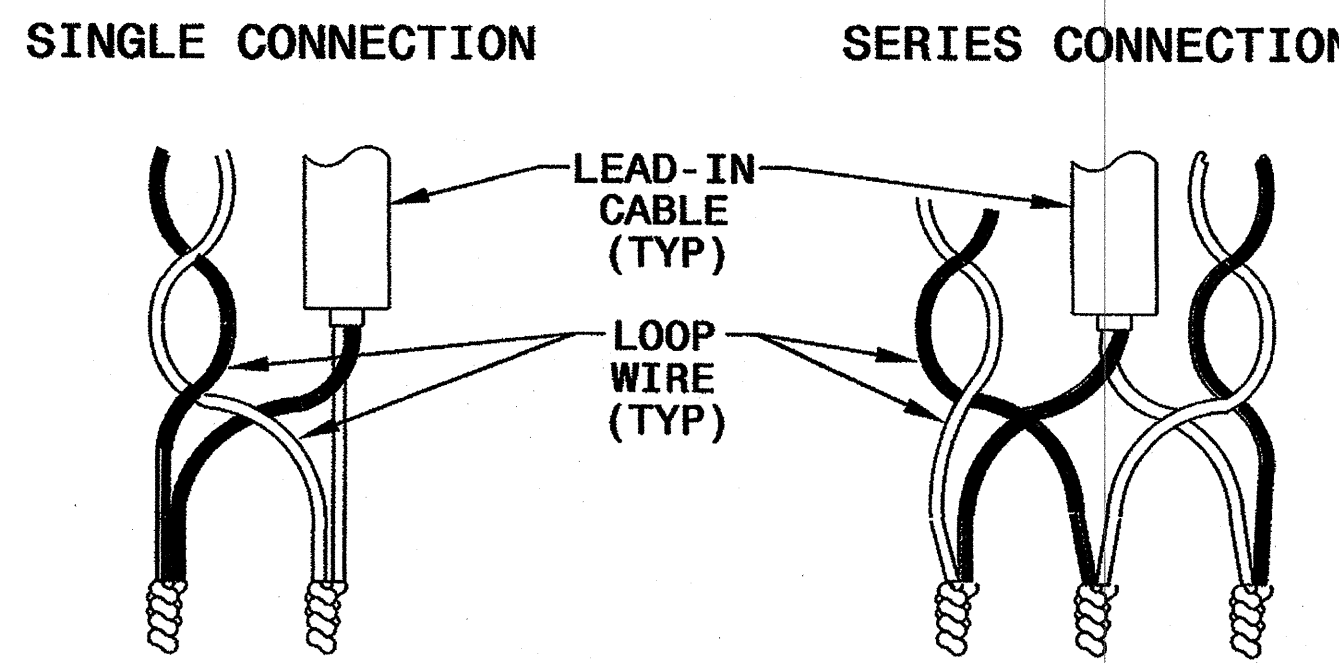

STEP 3. INSULATE EACH SOLDER JOINT SEPARATELY

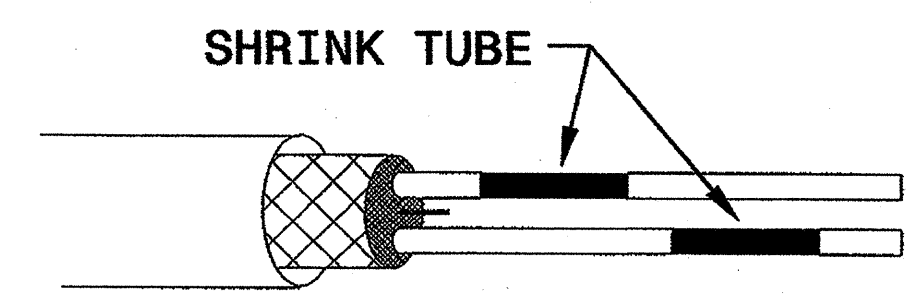

STEP 4. ENVIRONMENTALLY PROTECT SPLICE

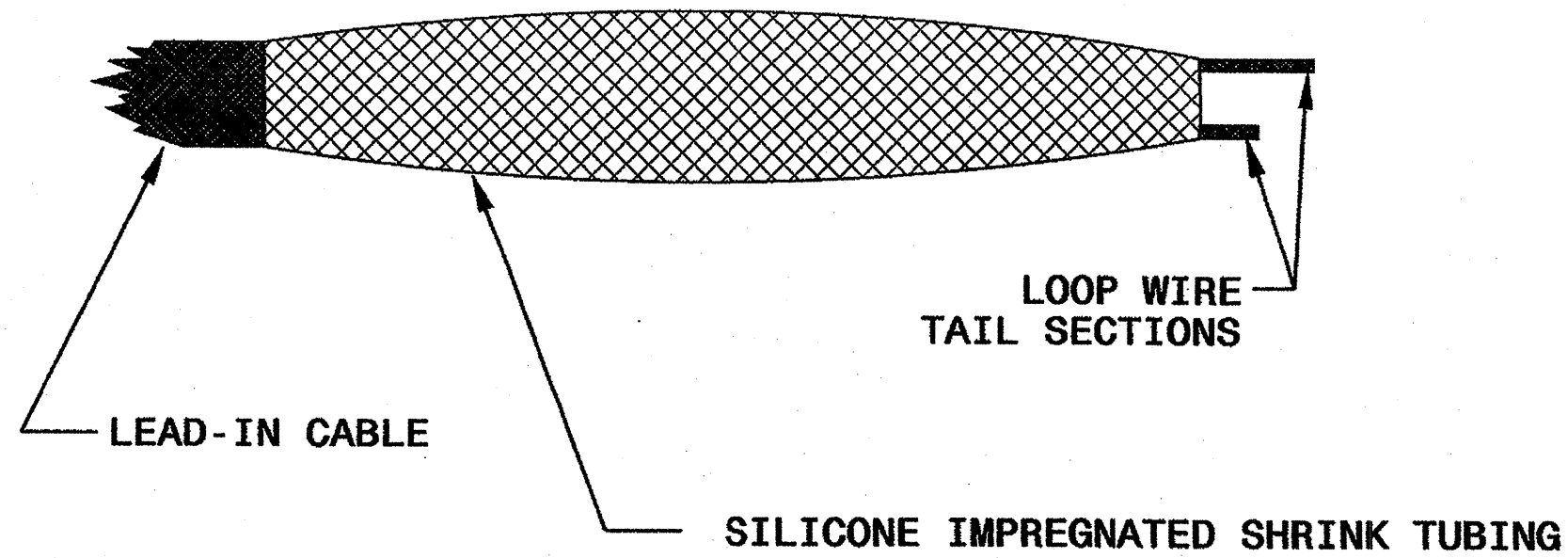

STATE OF
NORTH CAROLINA
DEPT. OF TRANSPORTATION
DIVISION OF HIGHWAYS
RALEIGH, N.C.

11-08

ENGLISH DETAIL DRAWING FOR
INDUCTIVE DETECTION LOOPS
SPlicing FOR LEAD-IN CABLE AND LOOP WIRE

SHEET 3 OF 3
1725D01

See Plate for Title

Prepared in the Offices of:
Intelligent Transportation Systems & Signals Unit
DEPARTMENT OF TRANSPORTATION
750 N. Greenfield Parkway
Garner, NC 27529

SEAL

Milton Dean 1/24/08
SIGNATURE DATE

24-Nov-2008 09:35
d:\work\1118840-standard plate sheets\1725D01_03.dgn
zmlittle

STATE OF NORTH CAROLINA DIVISION OF HIGHWAYS

STATE	PROJECT NO.	SHEET NO.
N.C.	R-2241A	Sig. 25
F.A. PROJ. NO.	M 1	
PROJECT ID. NO.		

STANDARD DRAWINGS FOR METAL POLES

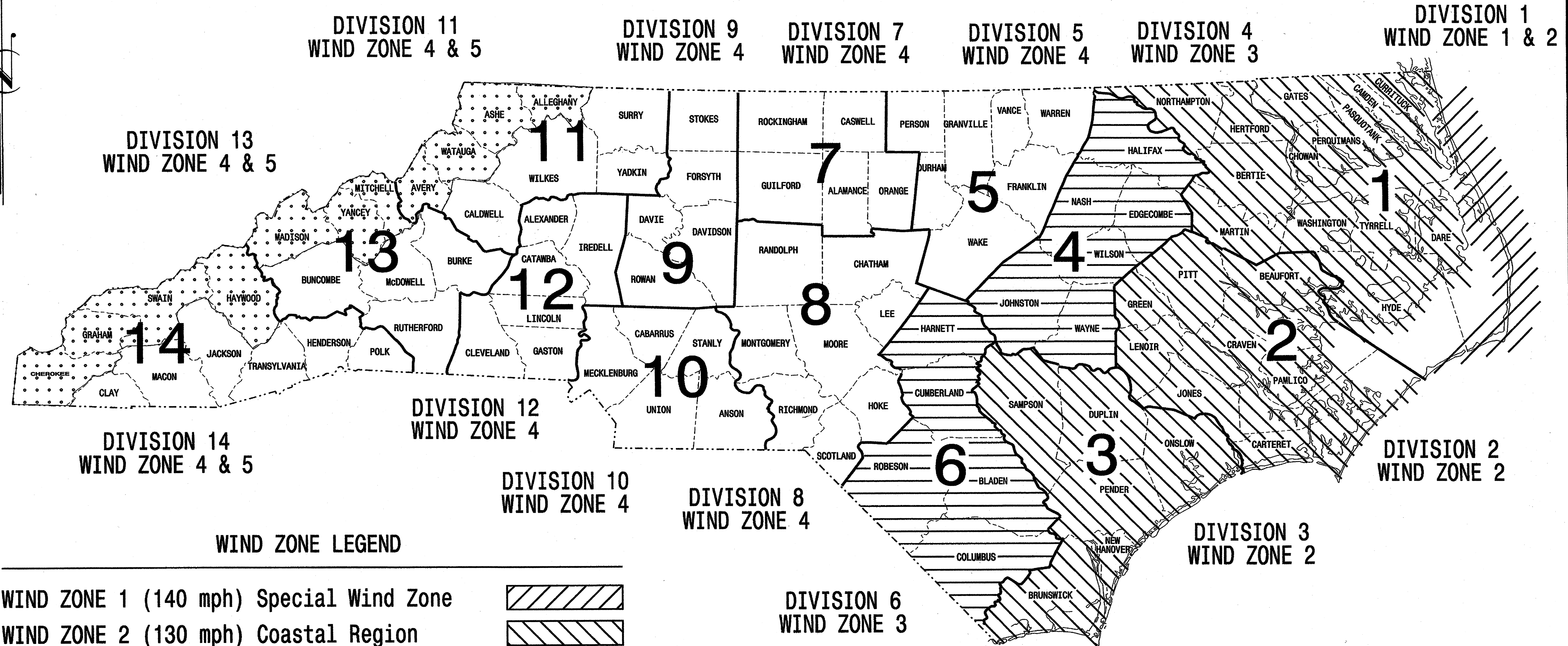

WIND ZONE LEGEND

WIND ZONE 1 (140 mph) Special Wind Zone	
WIND ZONE 2 (130 mph) Coastal Region	
WIND ZONE 3 (110 mph) Eastern Region	
WIND ZONE 4 (90 mph) Central & Mtn. Region	
WIND ZONE 5 (120 mph) Special Wind Zone	

<http://www.ncdot.org/doh/preconstruct/traffic/ITSS/ws/mpoles/poles.html>

Prepared In the Offices of:

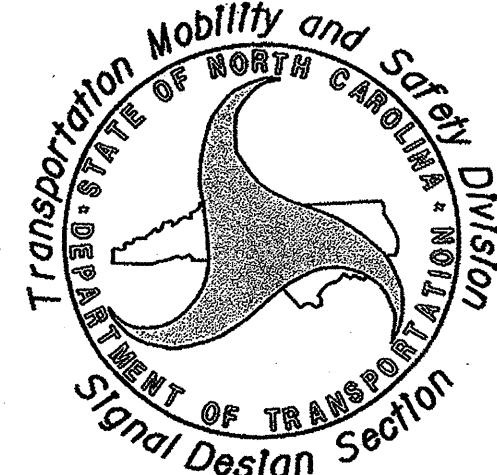

750 N. Greenfield Pkwy, Garner, NC 27529

Designed in conformance
with the
2002 Interim to the
4th Edition 2001

AASHTO

Standard Specifications for
Structural Supports for
Highway Signs, Luminaires,
and Traffic Signals

INDEX OF PLANS

DRAWING NUMBER	DESCRIPTION
M 1	Title Sheet
M 2	Fabrication Details - All Poles
M 3	Fabrication Details - Strain Poles
M 4,5	Fabrication Details - Mast Arm Poles
M 6	Construction Details - Strain Poles
M 7	Construction Details - Foundations
M 8	Standard Strain Poles

NCDOT CONTACTS:

MOBILITY AND SAFETY DIVISION - ITS and SIGNALS UNIT

- G. A. Fuller, P.E. - State ITS and Signals Engineer
- G. G. Murr, Jr., P.E. - State Signals Engineer
- D. C. Sarkar, P.E. - ITS and Signals Senior Structural Engineer
- C. F. Andrews, Jr. - ITS and Signals Structural Project Engineer
- M. Aslam - ITS and Signals Structural Project Engineer
- N. Bitting, P.E. - ITS and Signals Structural Project Engineer

SEAL

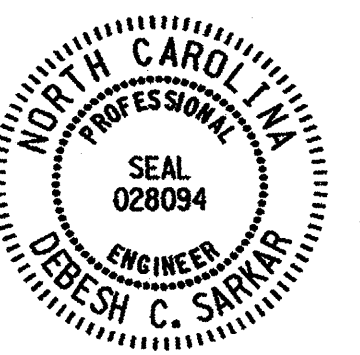

D. Sarkar 7.21.2009
SIGNATURE DATE

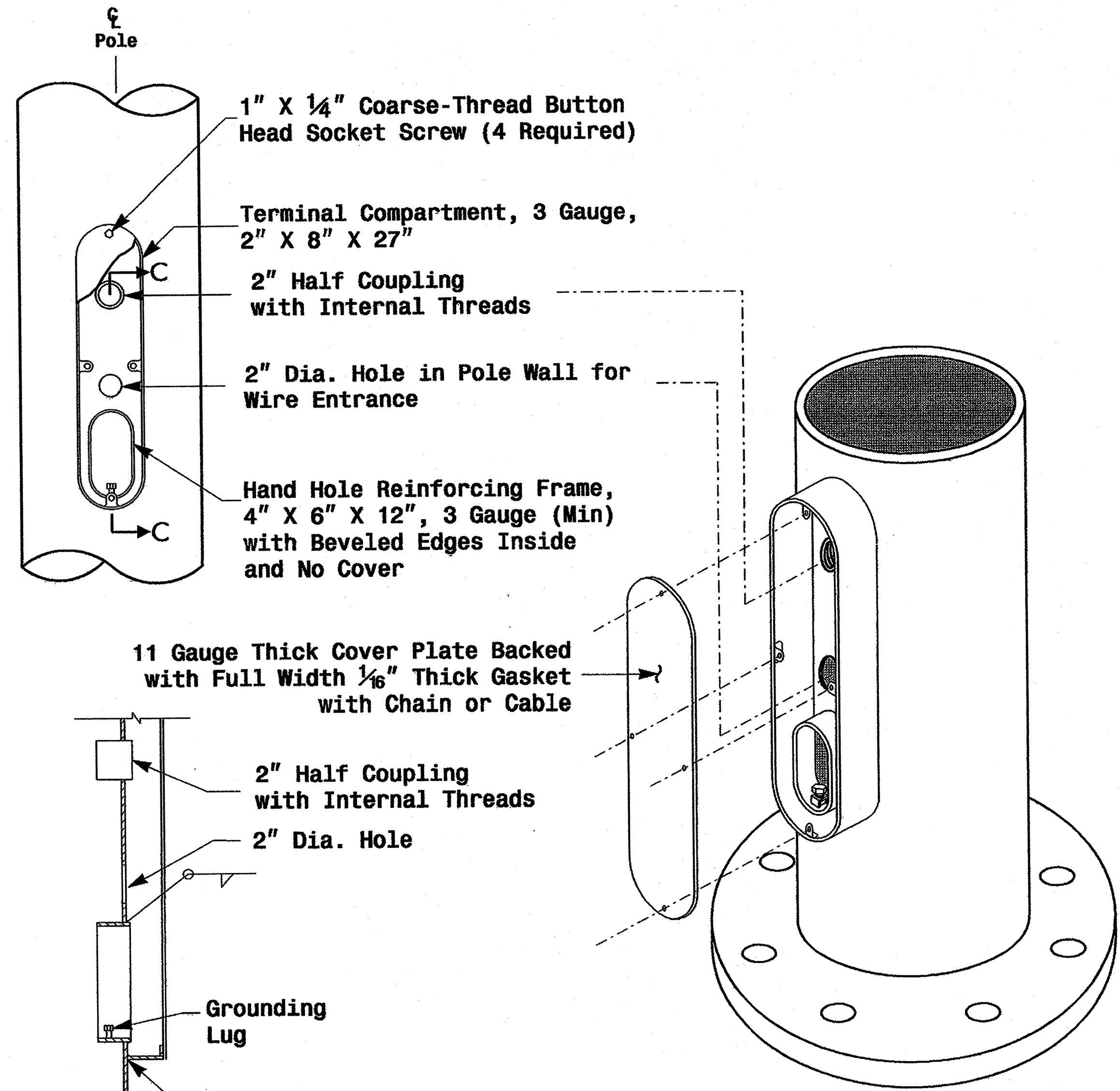

Note: Unless otherwise specified, locate Terminal Compartment 1 foot above the pole base plate at 180 degrees on the pole's radial index.

Terminal Compartment Detail

MFG _____	MFG. DATE: MM/YY _____
SHAFT D/T/L/Y _____	SECTION D/T/L/Y _____
ARM-A D/T/L/Y _____	NCDOT STANDARD _____
ARM-B D/T/L/Y _____	
A.B. DIA./B.C./L/Y _____	
NCDOT STANDARD _____	

MFG _____	MFG. DATE: MM/YY _____
SECTION D/T/L/Y _____	
NCDOT STANDARD _____	

Arm I.D. Tag
(Provide on each section of a multi-section mast arm)

Shaft I.D. Tag
(Provide on Strain Poles and Mast Arm Poles)

- Notes:
- 1) D= Diameter, T= Thickness, L= Length, Y= Yield Strength
 - 2) A.B. = Anchor Bolt
 - 3) B.C. = Bolt Circle of Anchor Bolts
 - 4) If Custom Design, use "NCDOT STANDARD" line for plan pole I.D.
 - 5) See drawing M4 for mounting positions of I.D. tags.

Identification Tag Details

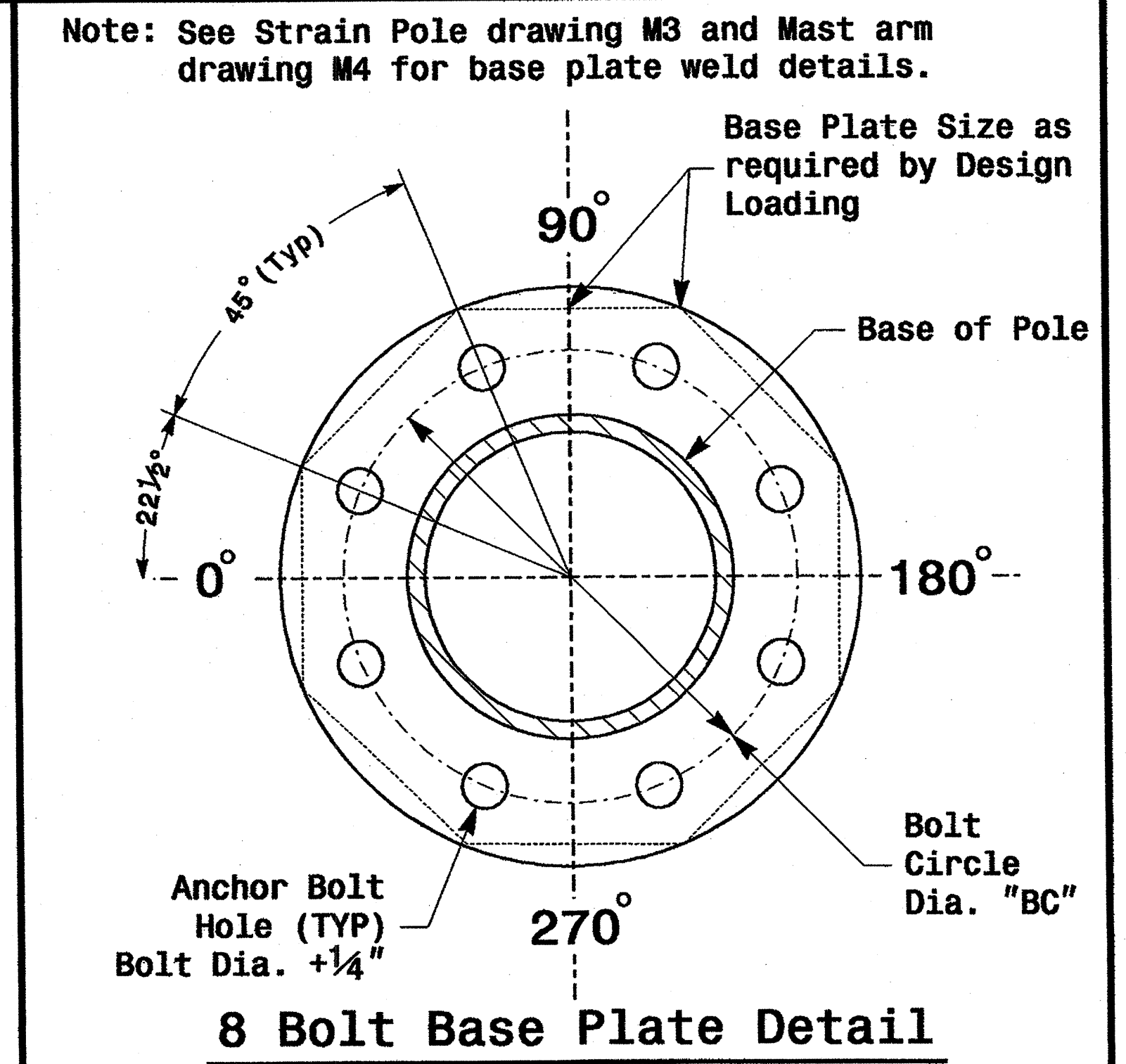
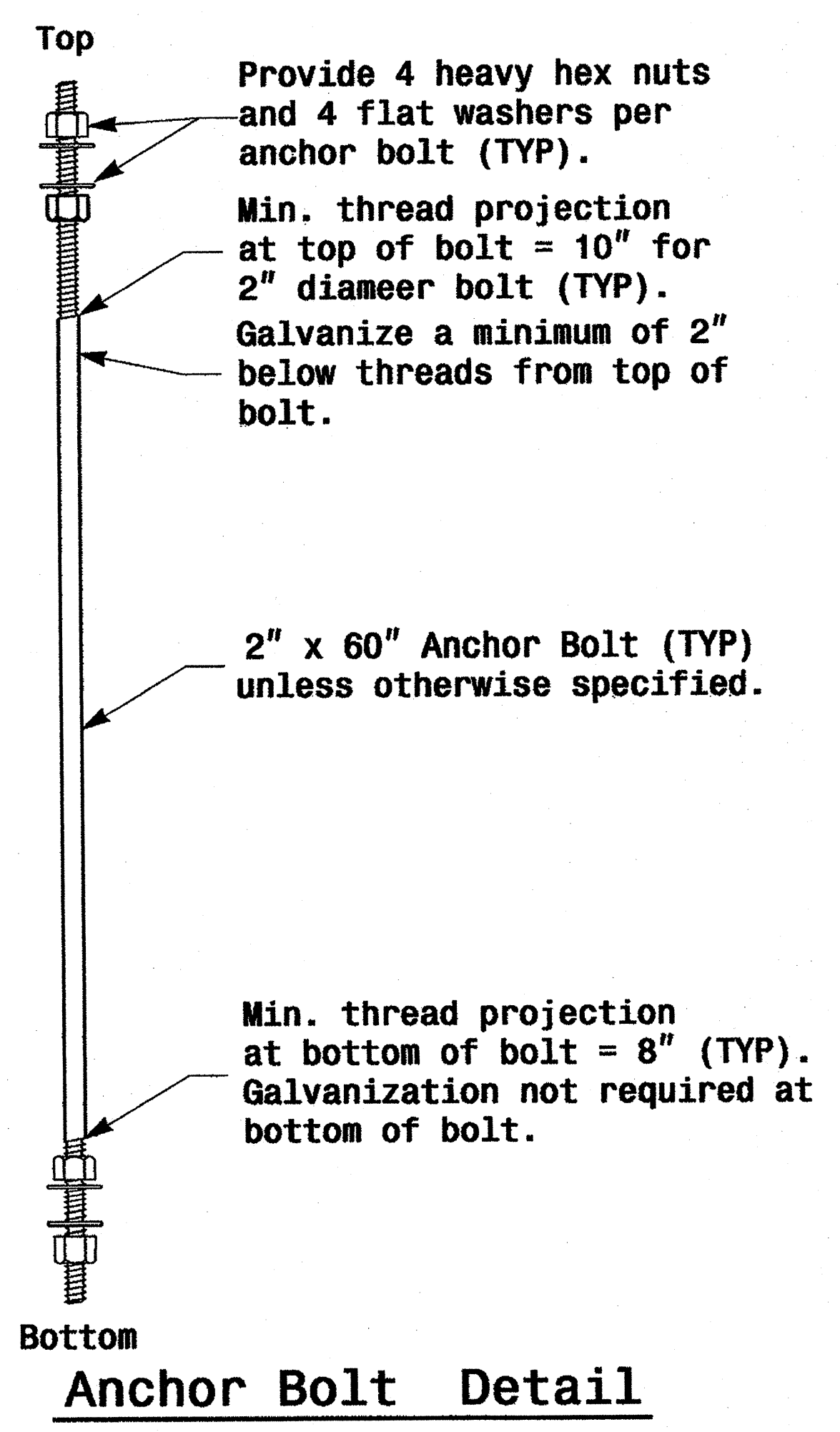
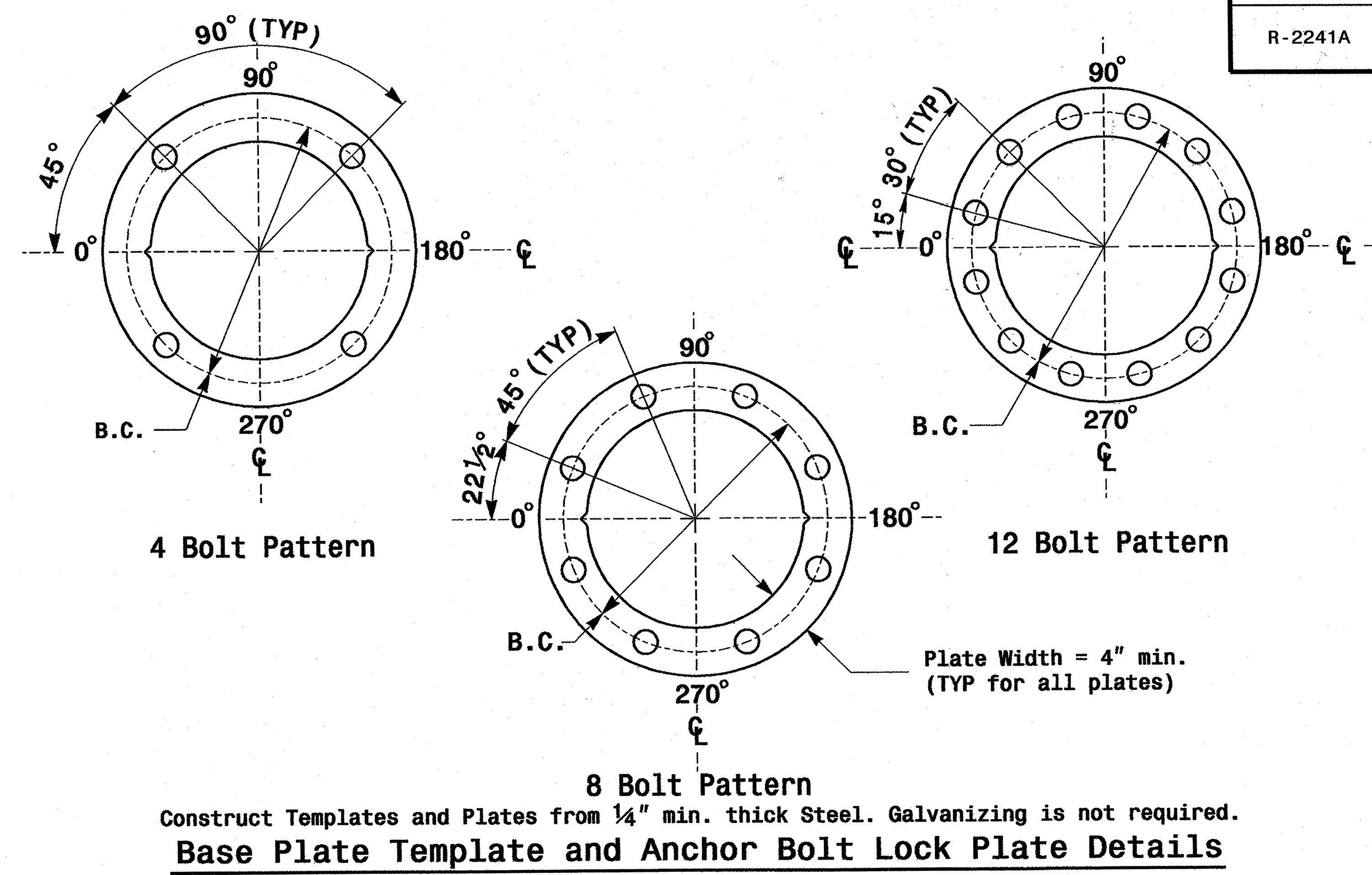

Prepared in the Office of 222 N. McDowell St., Raleigh, NC 27603	Typical Fabrication Details Common To All Metal Poles		SEAL SEAL 028094 P.L. Alexander ENGINEER NORTH CAROLINA
	PLAN DATE: May 2005 PREPARED BY: P.L. Alexander REVISIONS: _____ SCALE: 0 NA NONE	REVIEWED BY: C.F. Andrews REVIEWED BY: A.M. Esposito INIT. DATE _____	

Fabrication Details - All Poles

01-SEP-2005 16:22 01-SEP-2005 16:22 P:\01-SEP-2005 16:22 Poles Standard.dwg 004 me thru me.dgn

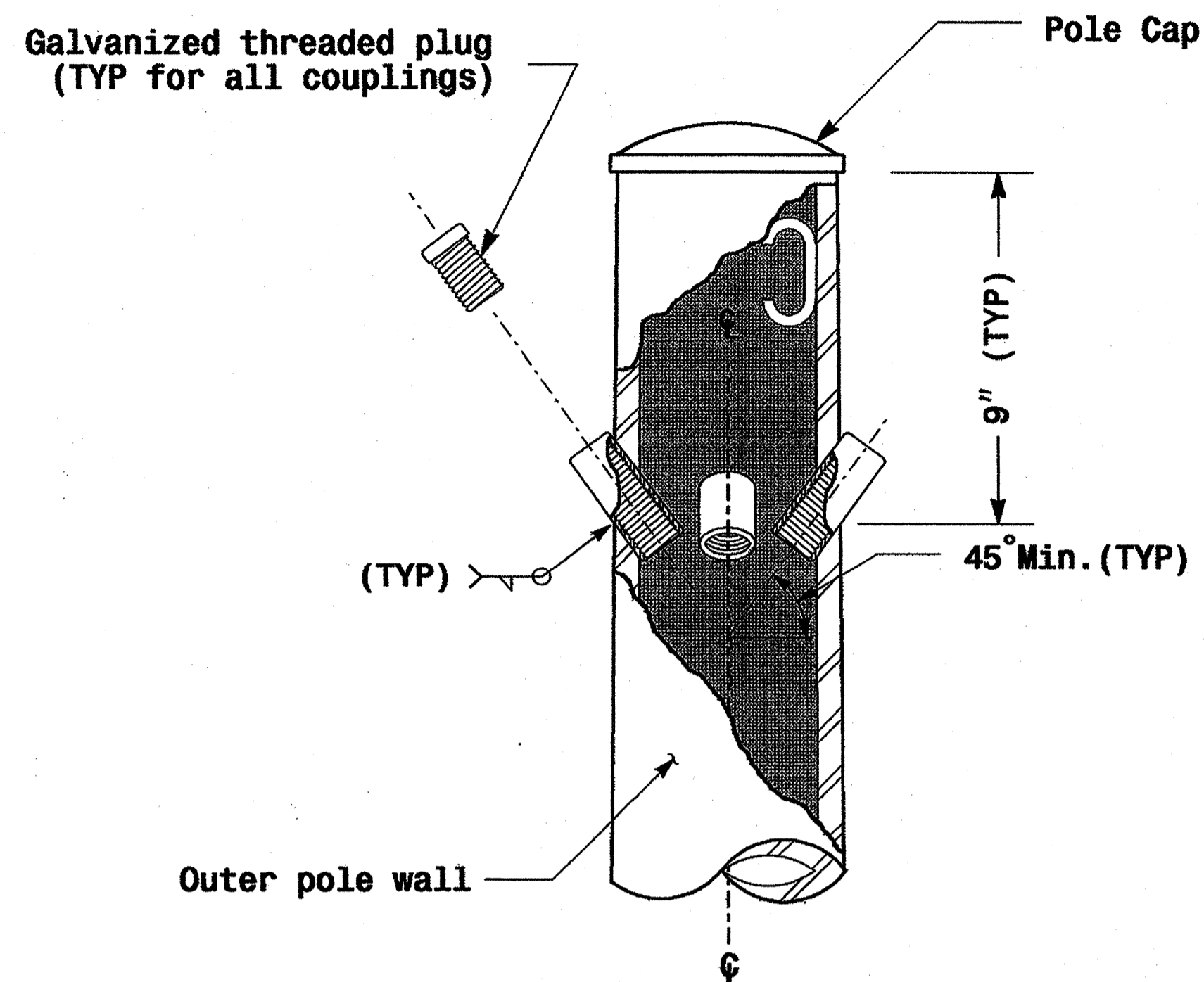

Cable Entrances at Top of Pole

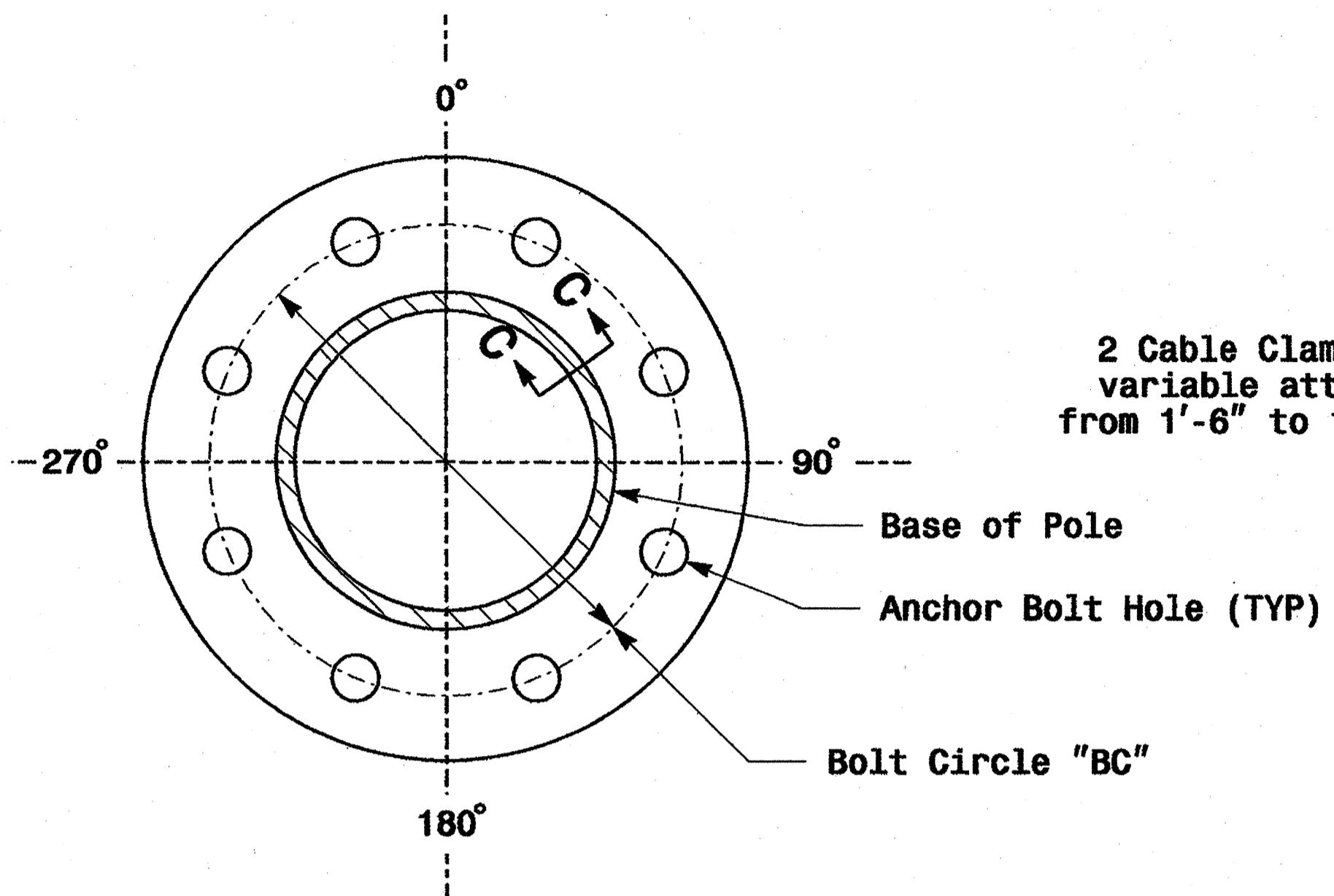

Section B-B
(See drawing M2)
Pole Base Plate

2 Cable Clamps designed for variable attachment heights from 1'-6" to 10' below the top of the pole.

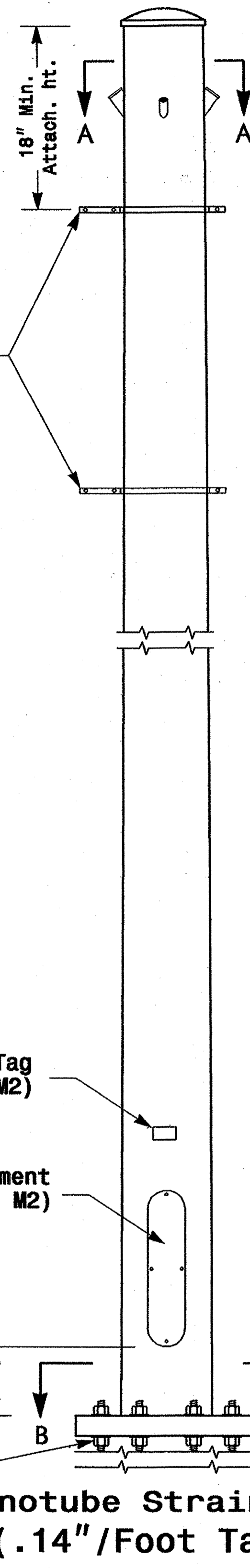

Monotube Strain Pole
(.14"/Foot Taper)

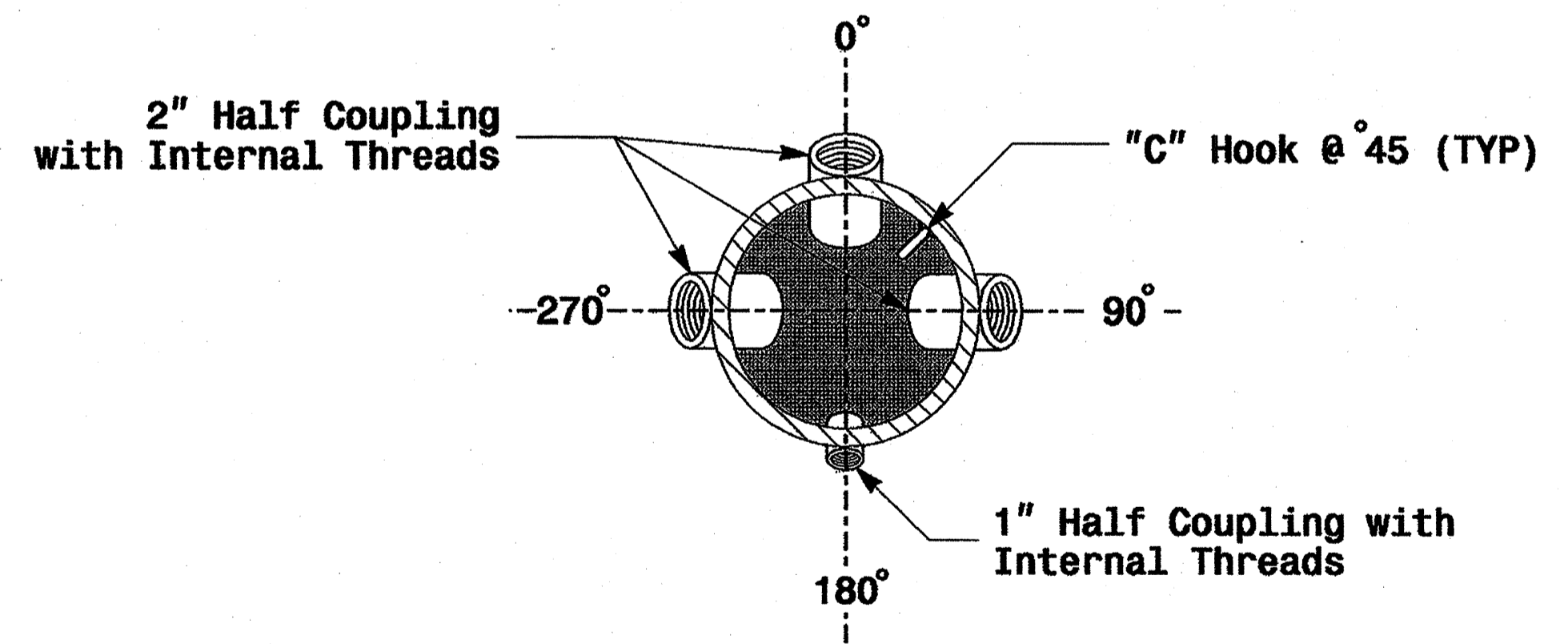

Radial Orientation for Factory Installed Accessories at Top of Pole

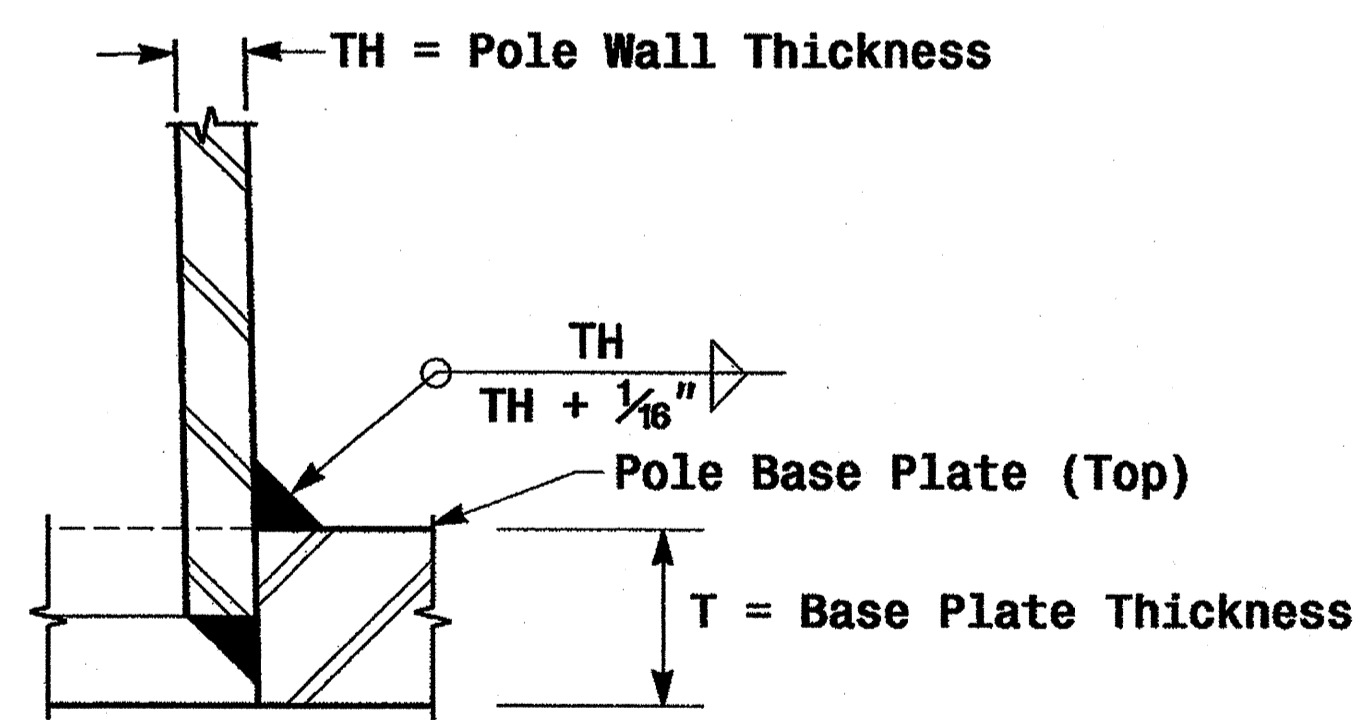

Socket Connection Weld Detail

01-SEP-2005 14:07 C:\nti\mcc\pgr\cupse2004\metal pole stender\cupse2004.m3.dgn P.L. Alexander

	Typical Fabrication Details For Strain Poles		
	PLAN DATE: May 2005 PREPARED BY: P.L. Alexander	REVIEWED BY: C.F. Andrews REVIEWED BY: A.W. Esposito	
SCALE: 0 NA NONE	REVISIONS:	INET. DATE	SIG. INVENTORY NO.

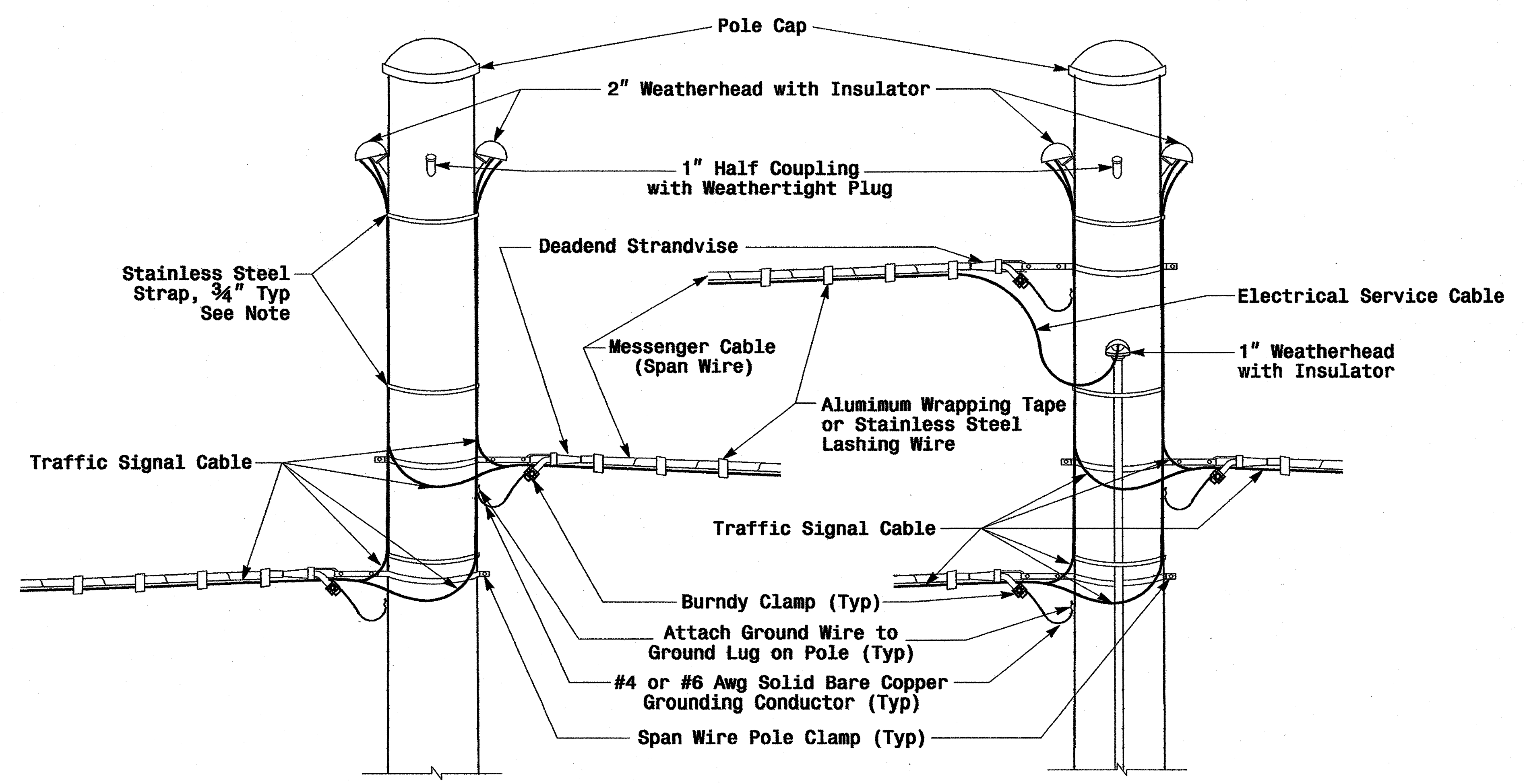

Note: Strap all signal cables to the side of the pole with 3/4\" stainless steel straps when the distance between the spanwire attachment clamp and the weatherheads exceeds 36\"

Strain Pole Attachments

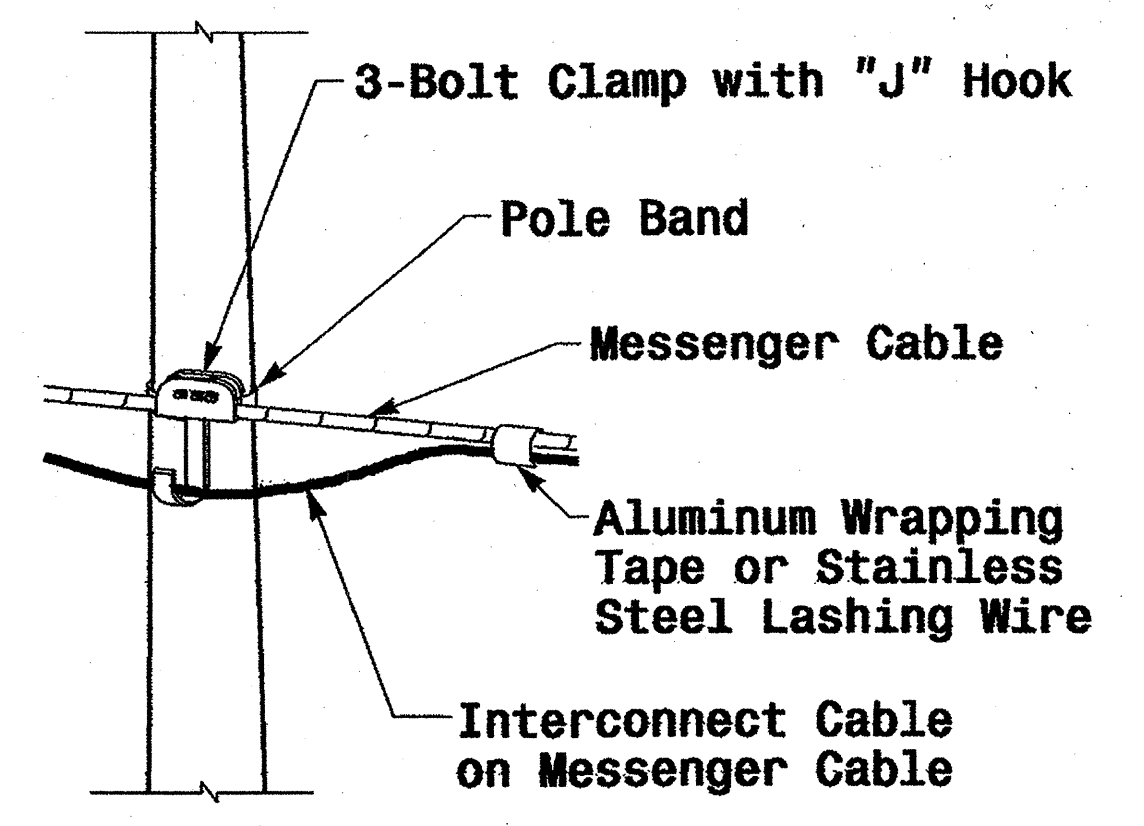

Attachment of Cable to Intermediate Metal Pole

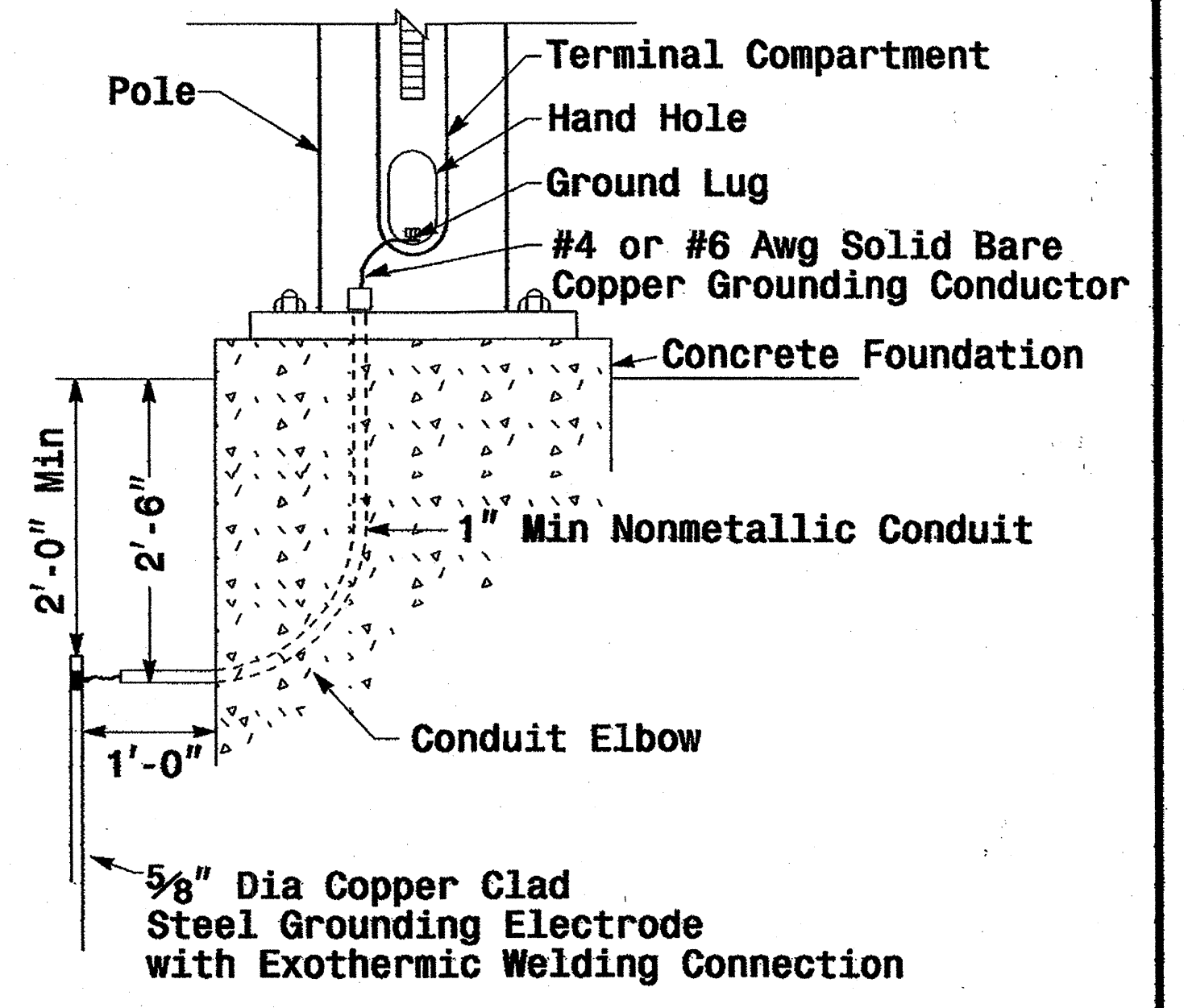

Metal Pole Grounding Detail

Construction Details - Strain Poles

01-SFP-2005.16.13
v:\work\les-un\work\groups\2004\metal pole standard\0404.mgd
pd alexander

	Construction Details Strain Poles		
	PLAN DATE: May 2005 PREPARED BY: C.F. ANDREWS	REVIEWED BY: P.L. ALEXANDER REVIEWED BY: D.C. SARKAR	
SCALE: 0 NA NONE		SIG. INVENTORY NO. _____	

Reinforcing Steel Bars

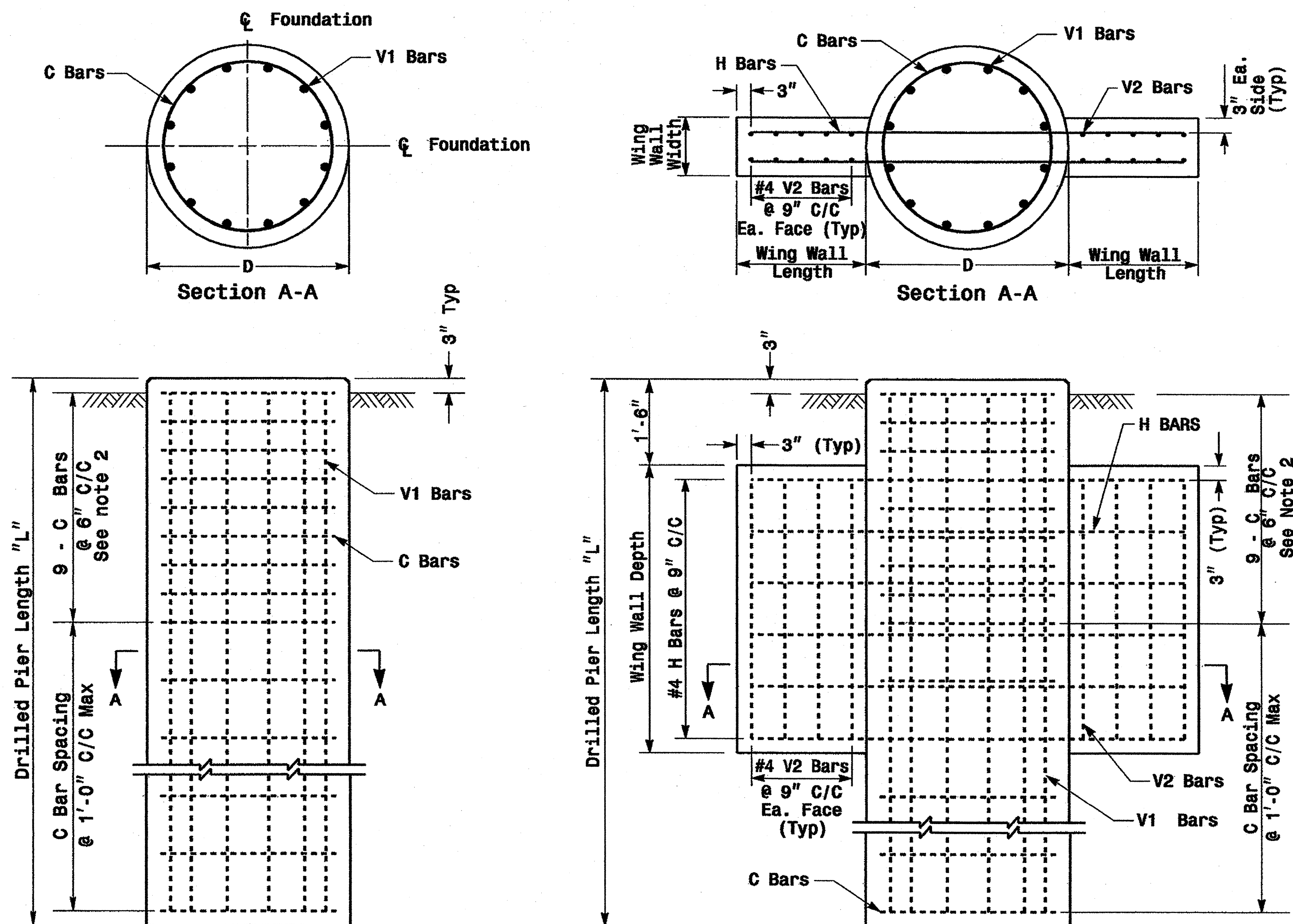

REINFORCING STEEL TABLE FOR STANDARD DRILL PIER SHAFT (42" & 48" DIAMETER)						
Shaft Dia. (in.)	Conc. Volume (cu. yds.)	Bar Name	No.	Size	Type	Length
42"	.356 x L	V1	9	#8	STR.	**
		C	*	#4	CIR.	10'-9"
48"	.465 x L	V1	12	#8	STR.	**
		C	*	#4	CIR.	12'-6"

* See Note No. 1
** See Note No. 3

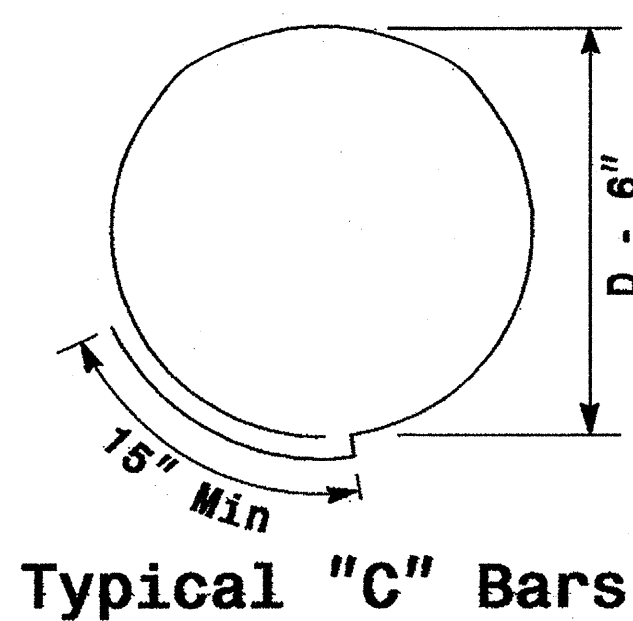

Typical "C" Bars

REINFORCING STEEL TABLE FOR STANDARD 42" and 48" DRILL PIER SHAFT WITH TYPE 1 AND TYPE 2 WING WALLS						
Wing Wall Type	Drill Pier Shaft Dia. (in.)	Reinforcing Steel				
		Bar Name	No.	Size	Type	Length
TYPE 1	42"	V1	9	#8	STR.	**
		V2	12	#4	STR.	2'-6"
		H	8	#4	STR.	6'-0"
		C	*	#4	CIR.	10'-9"
TYPE 2	42"	V1	9	#8	STR.	**
		V2	16	#4	STR.	4'-6"
		H	12	#4	STR.	9'-0"
		C	*	#4	CIR.	10'-9"
TYPE 2	48"	V1	12	#8	STR.	**
		V2	16	#4	STR.	4'-6"
		H	12	#4	STR.	9'-6"
		C	*	#4	CIR.	12'-6"

* See Note No. 1
** See Note No. 3

WING WALL DETAILS				
Wing Wall Type	Wing Wall Length (Ft.)	Wing Wall Width (Ft.)	Wing Wall Depth (Ft.)	Concrete Volume (Cu. Yds.)
TYPE 1	1'-6"	1'-0"	3'-0"	.4
TYPE 2	3'-0"	1'-0"	5'-0"	1.2

See Note No. 4

Typical Foundation Anchor Bolt Details

(Reinforcing Cage Not Shown for Clarity)

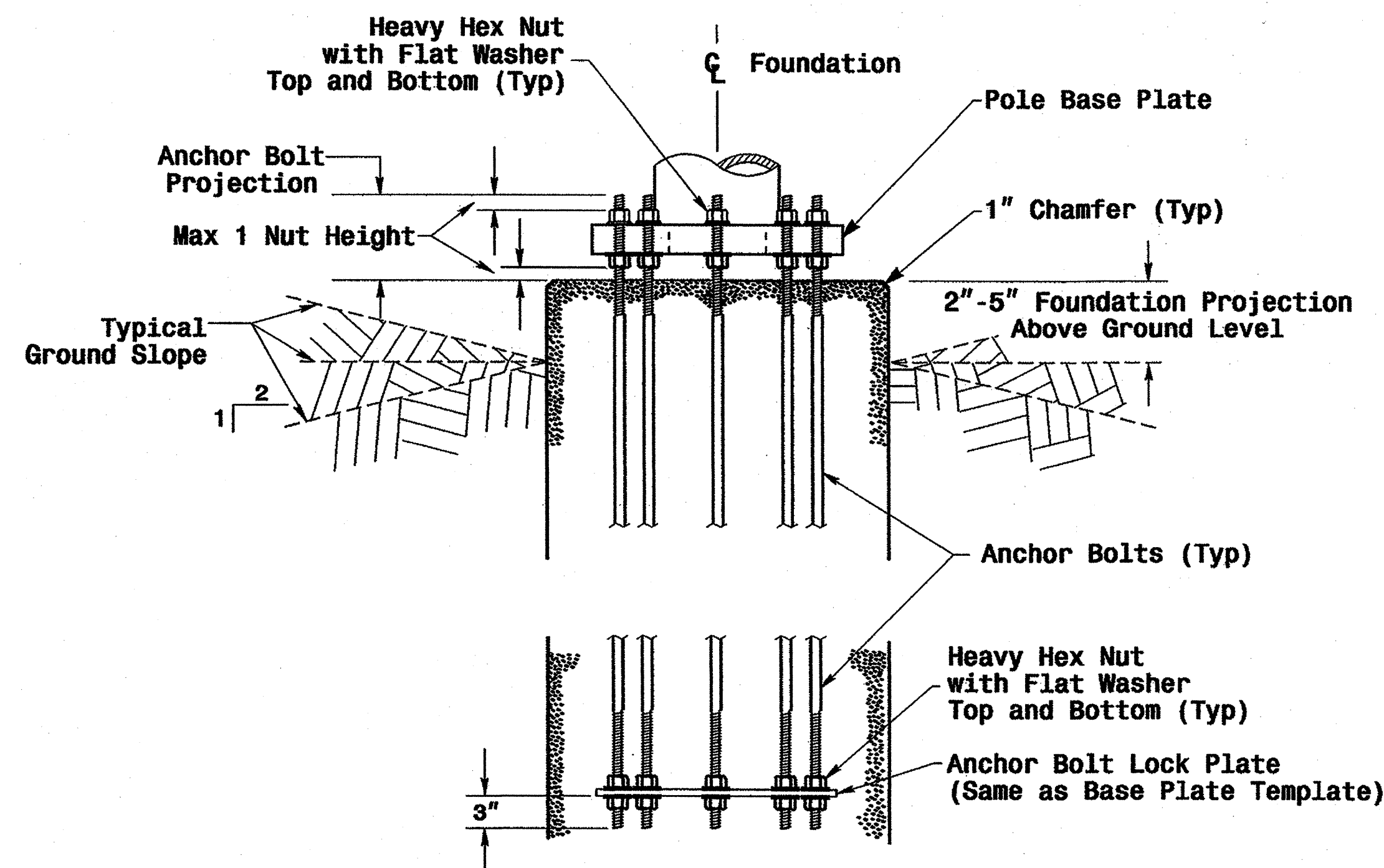

Typical Foundation Conduit Details

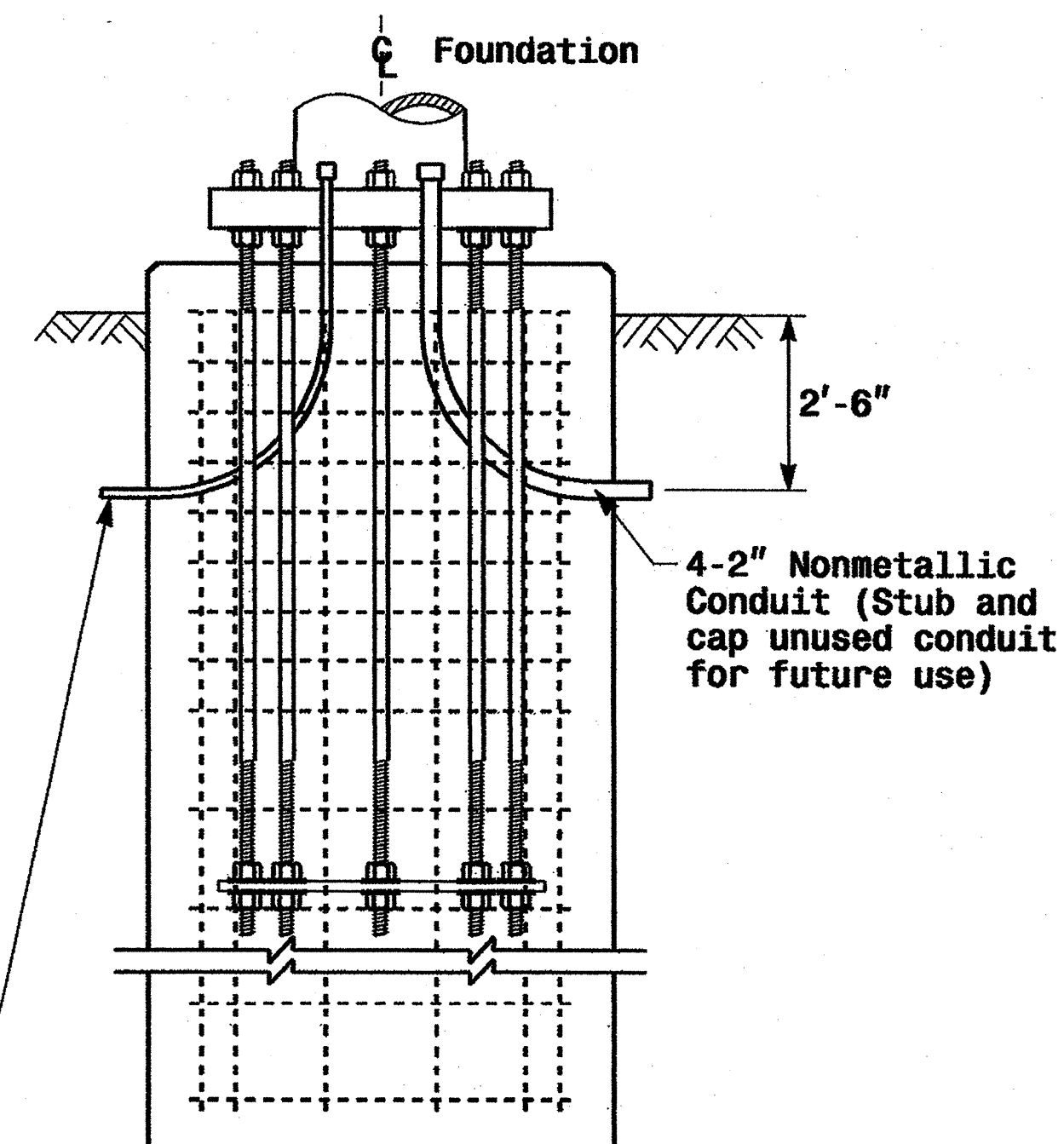

2-1" Nonmetallic Conduits for Electrical Service and Grounding Electrode Conductor

Notes

- The number of C-bars is based on foundation depth. For standard foundations, see sheet M 8.
- Circular tie reinforcing rings may be vertically adjusted by +/- 3" at a depth between 2'-0" and 3'-0" to facilitate the installation of electrical conduit entering in the cage.
- The length of V1-bars is based on foundation depth. For standard foundations, see sheet M 8.
- The quantities for steel and concrete shown in the Wing Wall Details Chart reflect the amount of material for 1 pair of wing walls (2 wing walls per drilled pier shaft.)

PROJECT REFERENCE NO. R-2241A
SHEET NO. Sig. 29
M 7

Construction Details - Foundations

	Construction Details Foundations		SEAL
	PLAN DATE: May 2005 PREPARED BY: C.F. ANDREWS	REVIEWED BY: P.L. ALEXANDER REVIEWED BY: A.M. ESPOSITO	REVISIONS INIT. DATE
SCALE: 0 NA NONE		SIG. INVENTORY NO.	

		STANDARD STRAIN POLES			STANDARD FOUNDATIONS 42" Diameter Drilled Pier Length (L) - Feet							
Case No.	Pole Height (Ft.)	Base Plate BC (In.)	Moment at the Pole Base (ft-kp)	Clay				Sand				
				Medium N-Value 4-8	Stiff N-Value 9-15	Very Stiff N-Value 16-30	Hard N-Value >30	Loose N-Value 4-10	Medium N-Value 11-30	Dense N-Value >30		
WIND ZONE 1	LIGHT	S26L3	26	25	280	20.5	14.0	11.5	9.5	18.0	16.0	14.0
		S30L3	30	25	310	21.0	14.5	11.5	9.5	18.5	16.5	14.5
		S35L3	35	25	350	22.5	15.0	12.0	10.0	19.5	17.5	15.5
	HEAVY	S30H3	30	29	450	25.5	16.5	13.0	11.0	21.0	18.5	16.5
		S35H3	35	29	540	26.0	17.0	13.5	11.5	22.0	19.5	17.0
	WIND ZONE 2	LIGHT	S26L2	26	23	250	19.5	13.5	11.0	9.0	18.0	15.5
S30L2			30	23	290	20.0	14.0	11.5	9.5	18.5	16.0	14.0
S35L2			35	23	315	21.0	14.5	11.5	9.5	19.0	16.5	14.5
HEAVY		S30H2	30	29	415	24.5	16.0	13.0	10.5	21.0	18.5	16.0
		S35H2	35	29	485	25.5	16.5	13.5	11.0	21.5	19.0	16.5
WIND ZONE 3		LIGHT	S26L2	26	23	250	18.5	13.0	10.5	9.0	17.5	15.0
	S30L2		30	23	290	19.5	13.5	11.0	9.0	18.0	15.5	14.0
	S35L2		35	23	315	20.0	14.0	11.5	9.5	18.5	16.0	14.5
	HEAVY	S30H2	30	29	415	23.0	15.5	12.5	10.0	20.5	17.5	16.0
		S35H2	35	29	485	24.0	16.0	13.0	10.5	21.0	18.0	16.5
	WIND ZONE 4	LIGHT	S26L1	26	22	195	18.0	13.0	10.5	9.0	16.5	14.5
S30L1			30	22	225	18.5	13.0	10.5	9.0	17.0	15.0	13.5
S35L1			35	22	255	19.0	13.5	11.0	9.0	17.5	15.5	14.0
HEAVY		S30H1	30	25	330	22.0	15.0	12.0	9.5	19.5	17.0	15.0
		S35H1	35	25	385	23.0	15.5	12.5	10.0	20.0	17.5	15.5
WIND ZONE 5		LIGHT	S26L2	26	23	250	19.0	13.5	10.5	9.0	17.5	15.5
	S30L2		30	23	290	20.0	14.0	11.0	9.5	18.0	16.0	14.0
	S35L2		35	23	315	21.0	14.5	11.5	10.0	19.0	16.5	14.5
	HEAVY	S30H2	30	29	415	23.5	15.5	12.5	10.5	21.0	18.0	16.0
		S35H2	35	29	485	25.0	16.5	13.0	11.0	21.5	18.5	16.5

Concrete Volume (cubic yards) = .356 X L

Fabrication Design Notes:

1. Values shown in "Moment at the Pole Base" column represents the minimum acceptable capacity allowable for design using a design CSR of 1.
2. Base plate thickness (T) is 2.0 inches.

Foundation Selection:

1. Perform a standard penetration test at each proposed foundation site to determine "N" value.
2. Select the appropriate wind zone from sheet M 1.
3. Select the soil type (Clay or Sand) that best describes the soil characteristics.
4. Get the appropriate pole case load number from the plans or from the Engineer.
5. Select the appropriate column in the chart based on soil type and "N" value. Select the appropriate row based on the pole load case. The foundation depth is the value where the column and the row intersect.

Standard Strain Poles

02-SEP-2005 12:42 v:\p02\iss-un\1\new-kr\cupae2004 metal pole standard2004.m8 std straln pole.dgn palalexander

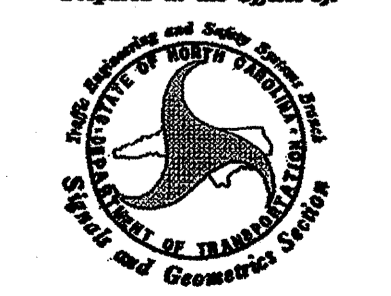
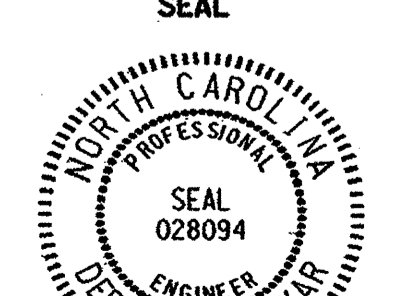
	Standard Strain Poles and Standard Foundations		
	PLAN DATE: May 2005 PREPARED BY: P.L. Alexander	REVIEWED BY: C.F. Andrews REVIEWED BY: A.W. Esposito	
REVISIONS:		INIT. DATE	SIGNATURE: D. Sarkar 9.2.2005 DATE