

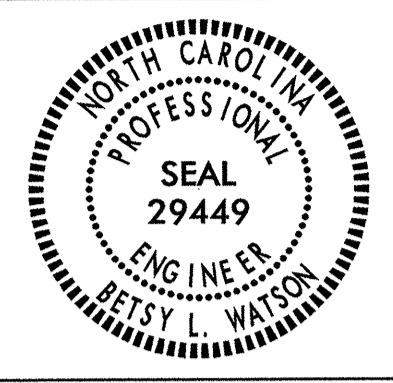

CONTRACT: C202960 T.I.P.: R-2241A

**STATE OF NORTH CAROLINA
 DEPARTMENT OF TRANSPORTATION**

**PAVEMENT MARKING PLAN
 PERSON COUNTY**

**LOCATION: US 501 FROM NC 49 IN ROXBORO
 TO SOUTH OF SR 1602**

TIP NO. R - 2241A	SHEET NO. PMP - 1
APPROVED: <i>Betsy L. Watson</i>	
DATE: <i>March 13, 2013</i>	
	
	
Stantec Consulting Services Inc. 801 Jones Franklin Road Suite 300 Raleigh, NC 27606 Tel. (919) 851-8888 Fax. (919) 851-7024 www.stantec.com License No. F-0672	

ROADWAY STANDARD DRAWINGS

THE FOLLOWING ROADWAY STANDARDS AS APPEAR IN "ROADWAY STANDARD DRAWINGS" - PROJECT SERVICES UNIT - N.C. DEPARTMENT OF TRANSPORTATION - RALEIGH, N.C., DATED JANUARY 2012 ARE APPLICABLE TO THIS PROJECT AND BY REFERENCE HEREBY ARE CONSIDERED A PART OF THESE PLANS:

STD. NO.	TITLE
1205.01	PAVEMENT MARKINGS - LINE TYPES & OFFSETS
1205.02	PAVEMENT MARKINGS - 2 LANE & MULTILANE ROADWAYS
1205.04	PAVEMENT MARKINGS - INTERSECTIONS
1205.05	PAVEMENT MARKINGS - TURN LANES
1205.08	PAVEMENT MARKINGS - SYMBOLS & WORD MESSAGES
1205.09	PAVEMENT MARKINGS - PAINTED ISLANDS
1205.11	PAVEMENT MARKINGS - RAILROAD CROSSINGS
1205.13	PAVEMENT MARKINGS - LANE REDUCTIONS
1250.01	RAISED PAVEMENT MARKERS - INSTALLATION SPACING
1253.01	RAISED PAVEMENT MARKERS - SNOWPLOWABLE
1261.01	GUARDRAIL & BARRIER DELINEATORS - INSTALLATION SPACING
1261.02	GUARDRAIL & BARRIER DELINEATORS - TYPES & MOUNTING
1262.01	GUARDRAIL END DELINEATION

GENERAL NOTES

THE FOLLOWING GENERAL NOTES APPLY AT ALL TIMES FOR THE DURATION OF THE CONSTRUCTION PROJECT, EXCEPT WHEN OTHERWISE NOTED IN THE PLAN, OR DIRECTED BY THE ENGINEER.

- A) INSTALL PAVEMENT MARKINGS AND PAVEMENT MARKERS ON THE FINAL SURFACE AS FOLLOWS:

ROAD NAME	MARKING	MARKER	
ALL ROADS	THERMOPLASTIC	SNOWPLOWABLE	
- B) TIE PROPOSED PAVEMENT MARKING LINES TO EXISTING PAVEMENT MARKING LINES.
- C) REMOVE/REPLACE ANY CONFLICTING/DAMAGED PAVEMENT MARKINGS AND MARKERS.
- D) PASSING ZONES WILL BE DETERMINED IN THE FIELD AND MUST BE APPROVED BY THE ENGINEER.
- E) STOP BAR LOCATION AT NON-SIGNALIZED INTERSECTIONS MAY BE ADJUSTED AS DIRECTED BY THE ENGINEER.
- F) ON ASPHALT SURFACES, USE HEATED-IN-PLACE THERMOPLASTIC OR EXTRUDED THERMOPLASTIC FOR STOP BARS, SYMBOLS, CHARACTERS AND DIAGONALS.

FINAL PAVEMENT MARKING SCHEDULE

SYMBOL	DESCRIPTION	PAY ITEM
T1	WHITE LINE, RR X	(16", 120 MIL) THERMOPLASTIC
T2	WHITE STOPBAR	(24", 120 MIL) THERMOPLASTIC
T8	2 FT-6FT/SP WHITE MINISKIP	(4", 120 MIL) THERMOPLASTIC
TA	WHITE EDGELINE	(4", 90 MIL) THERMOPLASTIC
TB	YELLOW EDGELINE	(4", 90 MIL) THERMOPLASTIC
TC	10 FT WHITE SKIP	(4", 120 MIL) THERMOPLASTIC
TD	3 FT-9 FT/SP WHITE MINISKIP	(4", 120 MIL) THERMOPLASTIC
TE	WHITE SOLID LANE LINE	(4", 120 MIL) THERMOPLASTIC
TF	10 FT YELLOW SKIP	(4", 120 MIL) THERMOPLASTIC
TH	YELLOW SINGLE CENTER	(4", 120 MIL) THERMOPLASTIC
TI	YELLOW DOUBLE CENTER	(4", 120 MIL) THERMOPLASTIC
TN	WHITE GORELINE	(8", 90 MIL) THERMOPLASTIC
TO	WHITE DIAGONAL	(8", 90 MIL) THERMOPLASTIC
TP	YELLOW DIAGONAL	(8", 90 MIL) THERMOPLASTIC
TU	WHITE DIAGONAL	(12", 90 MIL) THERMOPLASTIC
TV	YELLOW DIAGONAL	(12", 90 MIL) THERMOPLASTIC
UA	LEFT TURN ARROW	(90 MIL) THERMOPLASTIC
UB	RIGHT TURN ARROW	(90 MIL) THERMOPLASTIC
UC	STRAIGHT ARROW	(90 MIL) THERMOPLASTIC
UD	COMBO LEFT/STRAIGHT	(90 MIL) THERMOPLASTIC
UE	COMBO STRAIGHT/RIGHT	(90 MIL) THERMOPLASTIC
UF	COMBO LEFT/RIGHT	(90 MIL) THERMOPLASTIC
UG	COMBO LEFT/RIGHT/STRAIGHT	(90 MIL) THERMOPLASTIC
UI	ALPHANUMERIC CHAR	(120 MIL) THERMOPLASTIC
UP	MERGE ARROW	(90 MIL) THERMOPLASTIC

ALTERNATIVE CONCRETE DESIGN NOTE

IF CONCRETE IS USED ON MAINLINE, PLACE POLYUREA PAVEMENT MARKINGS WITH HIGHLY REFLECTIVE ELEMENTS AFTER REMOVING CURING COMPOUND AND SURFACE LAITANCE ON ALL CONCRETE SURFACES.

FOR STOP BARS, SYMBOLS, CHARACTERS, AND DIAGONALS USE COLD APPLIED PLASTIC.

TYPE III COLD APPLIED PLASTIC MAY BE USED IN LIEU OF TYPE II COLD APPLIED PLASTIC. IF TYPE III COLD APPLIED PLASTIC IS USED, IT SHALL BE PAID FOR USING THE TYPE II COLD APPLIED PLASTIC PAY ITEM.

INDEX

SHEET NO.	DESCRIPTION
PMP-1	PAVEMENT MARKING PLAN TITLE AND SCHEDULE SHEET
PMP-1A	REVISED PAVEMENT MARKING ROADWAY STANDARD DRAWING (SYMBOLS AND WORD MESSAGES)
PMP-2-25	PAVEMENT MARKING DETAIL

PLAN REVIEWED BY: N.C.D.O.T. SIGNING AND DELINEATION UNIT

SUSAN KUNZ SIGNING & DELINEATION REGIONAL ENGINEER
SAM COLEMAN SIGNING & DELINEATION PROJECT DESIGN ENGINEER

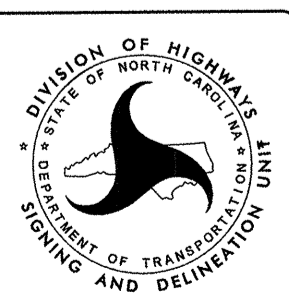

PLAN PREPARED BY:

BETSY L. WATSON, P.E. TRAFFIC ENGINEER
ROSI R. HENNEIN TRANSPORTATION TECHNICIAN

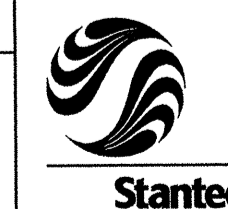

Stantec Consulting Services Inc.
 801 Jones Franklin Road
 Suite 300
 Raleigh, NC 27606
 Tel. (919) 851-8888
 Fax. (919) 851-7024
 www.stantec.com
 License No. F-0672

STATE OF
NORTH CAROLINA
DEPT. OF TRANSPORTATION
DIVISION OF HIGHWAYS
RALEIGH, N.C.

1-12

MULTI-LANE WIDTH "SCHOOL"

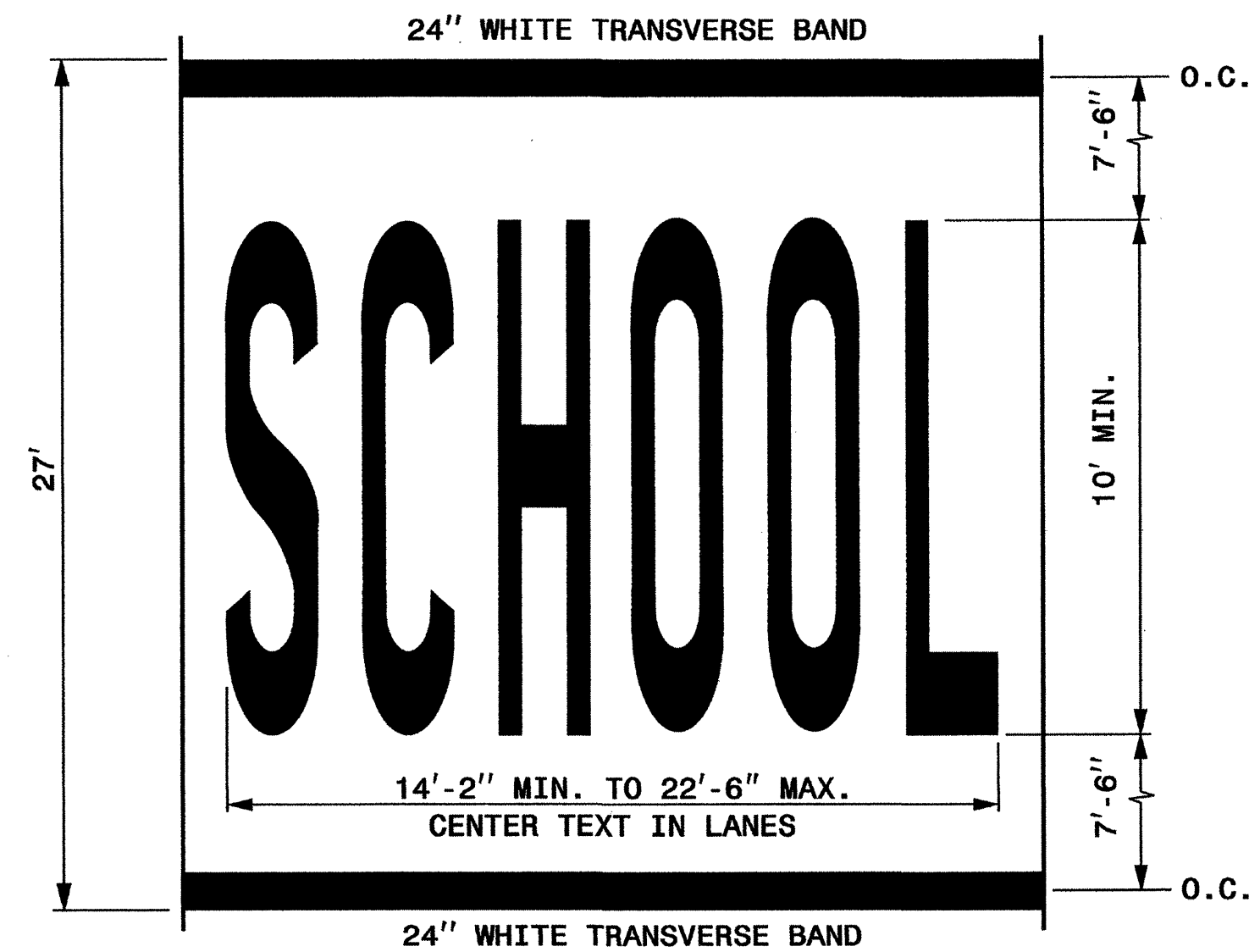

LETTER HEIGHT = 10' MIN.
LETTER WIDTH = 20"
SPACING = 10" MIN./30" MAX. (USE EQUAL SPACING BETWEEN LETTERS)

NOTE: THE TWO-LANE PAVEMENT MARKING DIMENSIONS OF "SCHOOL" SHOWN IN PART 7 OF THE MUTCD MAY ALSO BE USED.

SINGLE LANE WIDTH "SCHOOL"

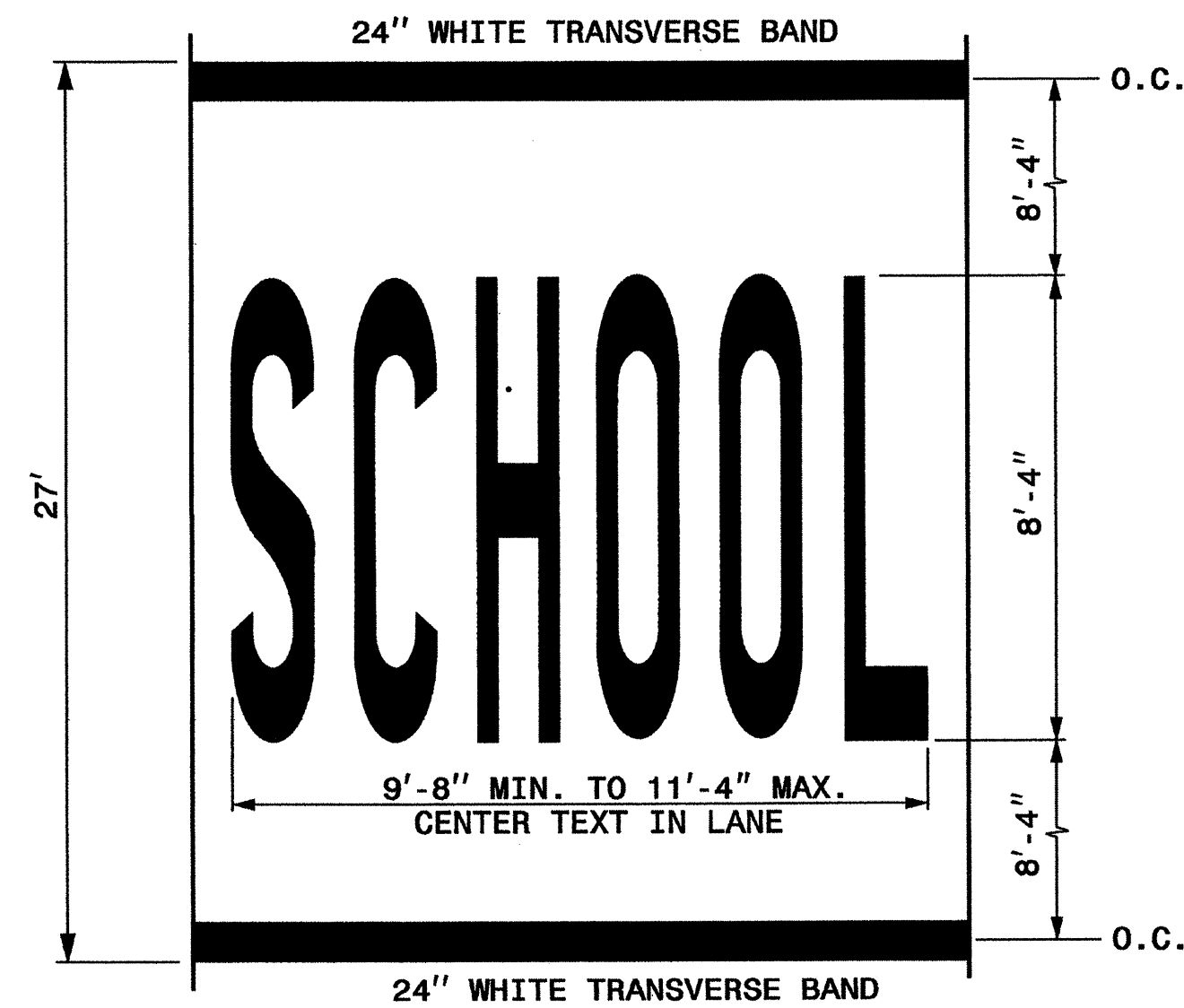

LETTER HEIGHT = 8'-4"
LETTER WIDTH = 16"
SPACING = 4" MIN./8" MAX. (USE EQUAL SPACING BETWEEN LETTERS)

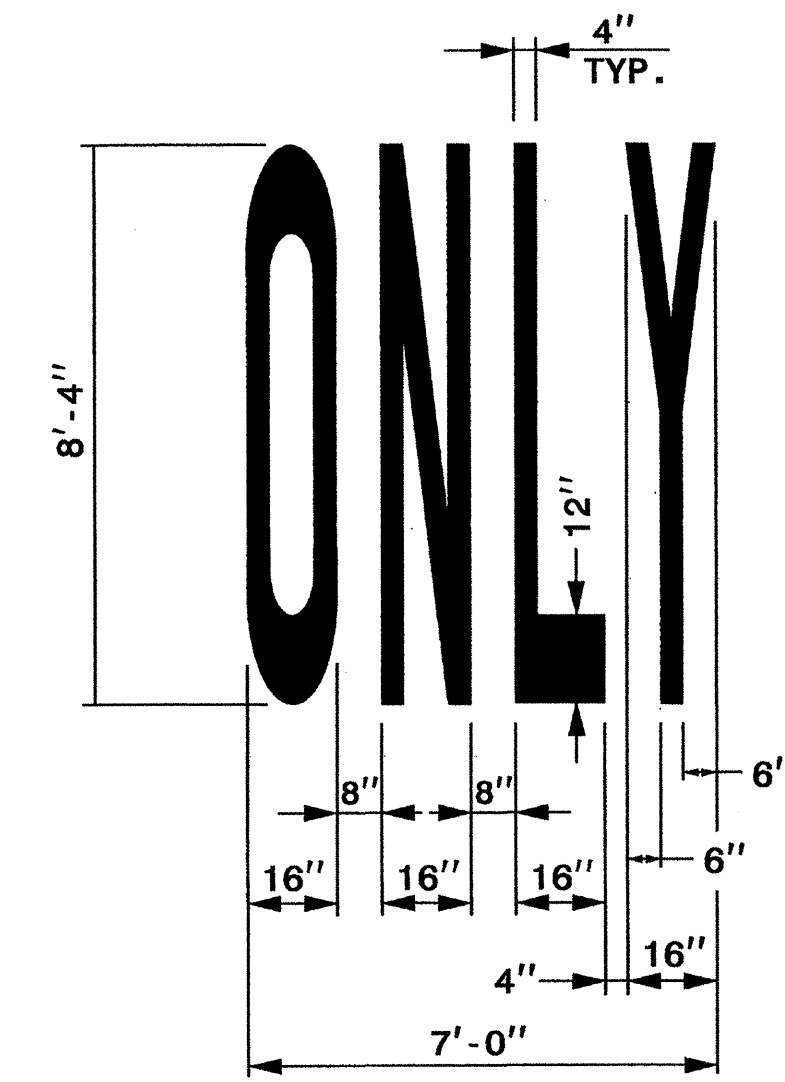

ENGLISH DETAIL DRAWING FOR
PAVEMENT MARKINGS
SYMBOLS AND WORD MESSAGES

RAILROAD RXR SYMBOL

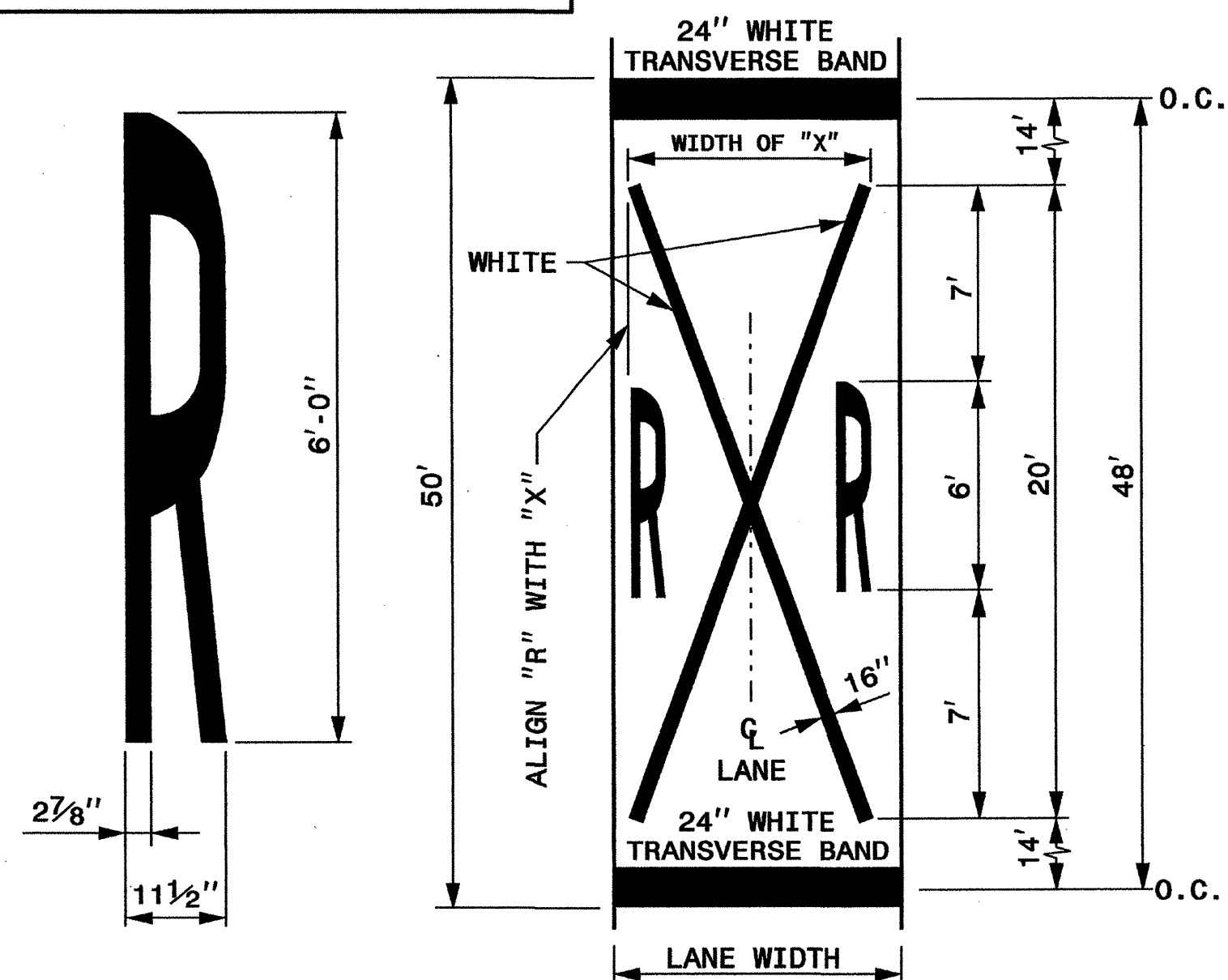

LANE WIDTH (FEET)	WIDTH OF "X" (FEET)
8' ≤ W ≤ 9'	7'
9' < W ≤ 12'	8'
W > 12'	10'

GENERAL NOTES:



- 1- THE SCHOOL PAVEMENT MARKING CONSISTS OF SIX (6) CHARACTERS. THE TWO (2) 24" TRANSVERSE BANDS WILL BE PAID FOR UNDER A SEPARATE PAY ITEM. REFER TO ROADWAY STANDARD DRAWING 1205.10 FOR ADDITIONAL PAVEMENT MARKING GUIDANCE.
- 2- PAVEMENT MARKING IN ADVANCE OF A HIGHWAY-RAIL CROSSING SHALL CONSIST OF TWO (2) CHARACTERS AND TWO (2) 16" LINES (FORMING AN X) WHICH ARE PAID FOR UNDER TWO SEPARATE PAY ITEMS. THE TWO (2) 24" TRANSVERSE BANDS WILL BE PAID FOR UNDER A SEPARATE PAY ITEM. REFER TO ROADWAY STANDARD DRAWING 1205.11 FOR ADDITIONAL PAVEMENT MARKING GUIDANCE.

STATE OF
NORTH CAROLINA
DEPT. OF TRANSPORTATION
DIVISION OF HIGHWAYS
RALEIGH, N.C.

1-12

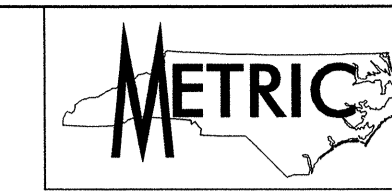
ENGLISH DETAIL DRAWING FOR
PAVEMENT MARKINGS
SYMBOLS AND WORD MESSAGES



TIP NO. R-2241A	SHEET NO. PMP-2
APPROVED: <i>Betsy L. Watson</i>	
DATE: 8/1/12	
SEAL	
	
	
Stantec Consulting Services Inc. 801 Jones Franklin Road Suite 300 Raleigh, NC 27606 Tel. (919) 851-6866 Fax. (919) 851-7024 www.stantec.com License No. F-0672	

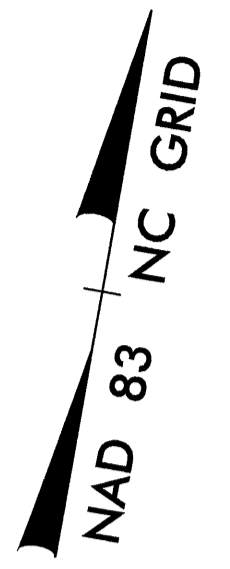

BEGIN PAVEMENT MARKING PLAN
R-2241A -L- STA. 10+20

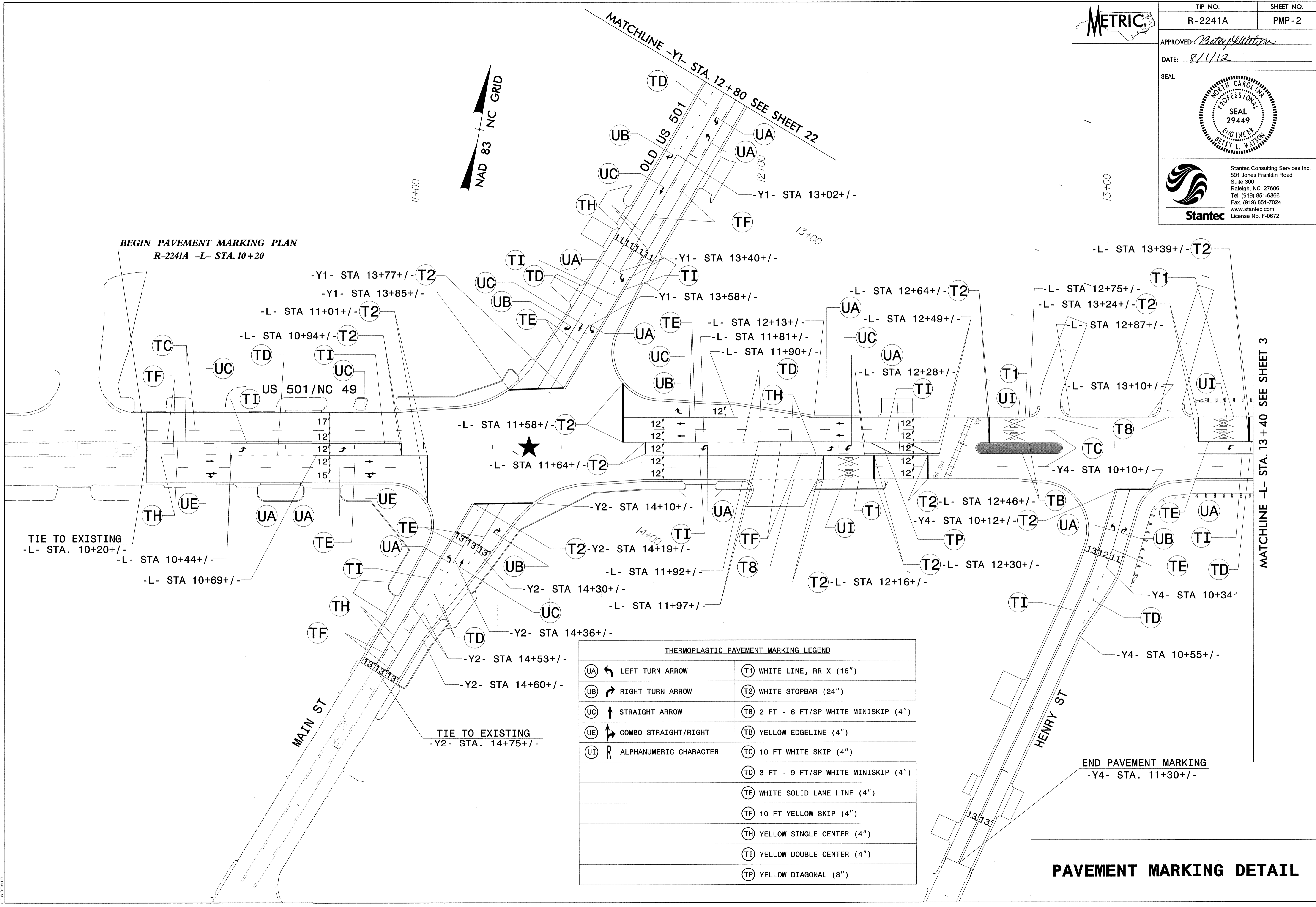

THERMOPLASTIC PAVEMENT MARKING LEGEND	
UA ↶ LEFT TURN ARROW	T1 WHITE LINE, RR X (16")
UB ↷ RIGHT TURN ARROW	T2 WHITE STOPBAR (24")
UC ↑ STRAIGHT ARROW	T8 2 FT - 6 FT/SP WHITE MINISKIP (4")
UE ↘ COMBO STRAIGHT/RIGHT	TB YELLOW EDGELINE (4")
UI R ALPHANUMERIC CHARACTER	TC 10 FT WHITE SKIP (4")
	TD 3 FT - 9 FT/SP WHITE MINISKIP (4")
	TE WHITE SOLID LANE LINE (4")
	TF 10 FT YELLOW SKIP (4")
	TH YELLOW SINGLE CENTER (4")
	TI YELLOW DOUBLE CENTER (4")
	TP YELLOW DIAGONAL (8")

PAVEMENT MARKING DETAIL

8/1/2012 8:51:08 AM C:\Users\pmp2241a\Documents\Projects\2241A\pmp_02.dgn

MATCHLINE -L- STA. 13+40 SEE SHEET 3

MATCHLINE -Y1- STA. 12+80 SEE SHEET 22

TIE TO EXISTING
-L- STA. 10+20+/-

TIE TO EXISTING
-Y2- STA. 14+75+/-

END PAVEMENT MARKING
-Y4- STA. 11+30+/-



TIP NO. R-2241A	SHEET NO. PMP-3
--------------------	--------------------

APPROVED: *Betsy L. Watson*

DATE: 8/1/12

SEAL

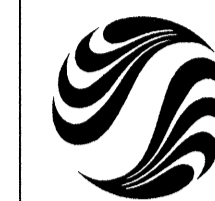
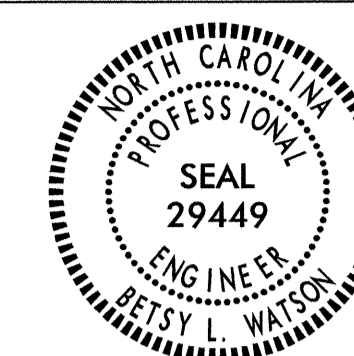

Stantec Consulting Services Inc.
801 Jones Franklin Road
Suite 300
Raleigh, NC 27606
Tel. (919) 851-8886
Fax. (919) 851-7024
www.stantec.com
License No. F-0672

NAD 83
NC GRID

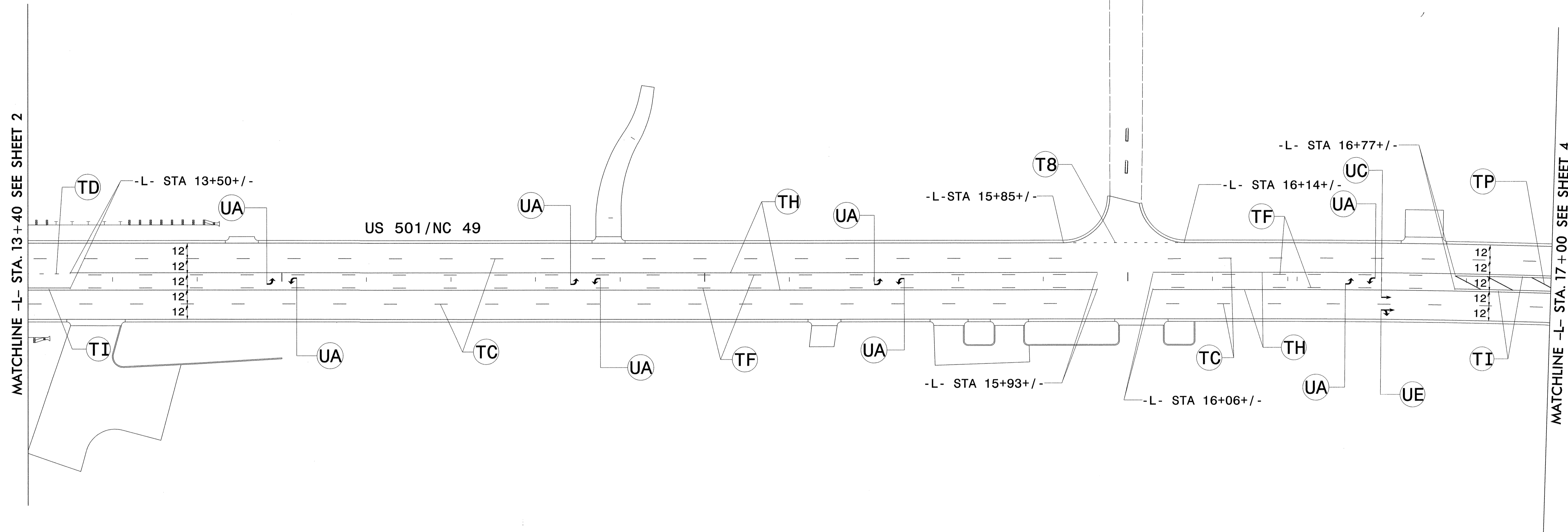

THERMOPLASTIC PAVEMENT MARKING LEGEND	
UA ← LEFT TURN ARROW	T8 2 FT - 6 FT/SP WHITE MINISKIP (4")
UC ↑ STRAIGHT ARROW	TC 10 FT WHITE SKIP (4")
UE ↗ COMBO STRAIGHT/RIGHT	TD 3 FT - 9 FT/SP WHITE MINISKIP (4")
	TF 10 FT YELLOW SKIP (4")
	TH YELLOW SINGLE CENTER (4")
	TI YELLOW DOUBLE CENTER (4")
	TP YELLOW DIAGONAL (8")

PAVEMENT MARKING DETAIL

METRIC

TIP NO. R-2241A SHEET NO. PMP-4

APPROVED: *Betsy L. Watson*

DATE: 8/1/12

SEAL

Stantec Consulting Services Inc.
801 Jones Franklin Road
Suite 300
Raleigh, NC 27606
Tel. (919) 851-6866
Fax. (919) 851-7024
www.stantec.com
License No. F-0672

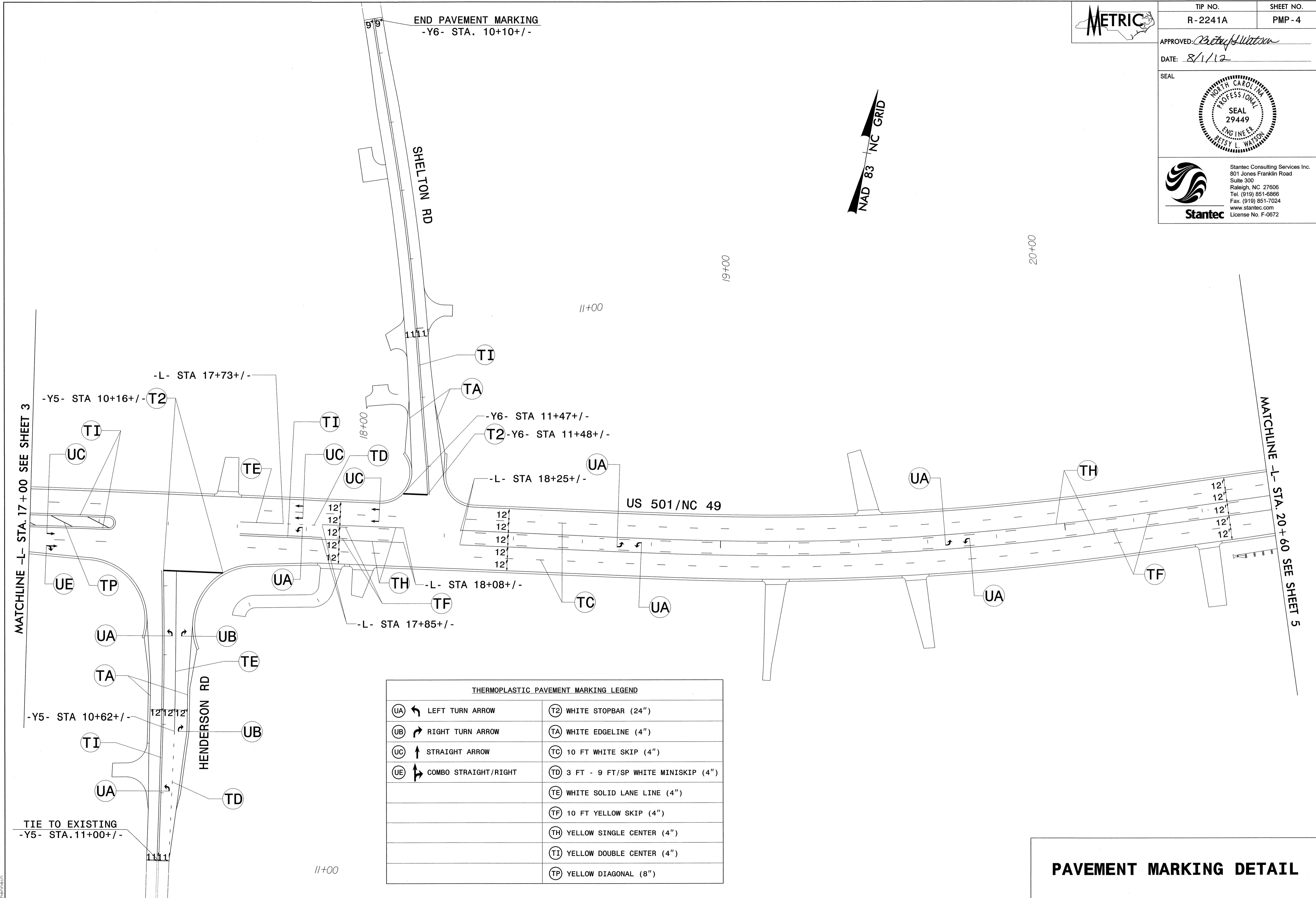
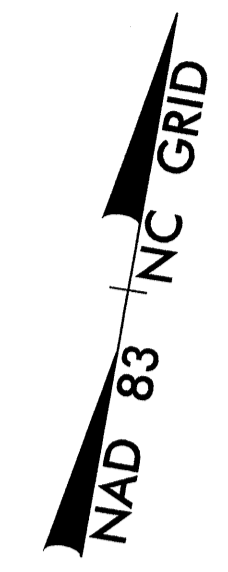



THERMOPLASTIC PAVEMENT MARKING LEGEND

(UA) ←	LEFT TURN ARROW	(T2)	WHITE STOPBAR (24")
(UB) ↗	RIGHT TURN ARROW	(TA)	WHITE EDGELINE (4")
(UC) ↑	STRAIGHT ARROW	(TC)	10 FT WHITE SKIP (4")
(UE) ↗	COMBO STRAIGHT/RIGHT	(TD)	3 FT - 9 FT/SP WHITE MINISKIP (4")
		(TE)	WHITE SOLID LANE LINE (4")
		(TF)	10 FT YELLOW SKIP (4")
		(TH)	YELLOW SINGLE CENTER (4")
		(TI)	YELLOW DOUBLE CENTER (4")
		(TP)	YELLOW DIAGONAL (8")

PAVEMENT MARKING DETAIL

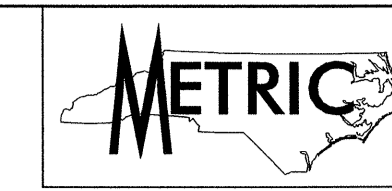
8/1/2012 10:51:33 AM C:\Users\jwatson\Documents\Projects\2241A\pmp_04.dgn



TIP NO. R-2241A	SHEET NO. PMP-5
APPROVED: <i>Betsy L. Watson</i>	
DATE: 8/1/12	
SEAL	
	
	
Stantec Consulting Services Inc. 801 Jones Franklin Road Suite 300 Raleigh, NC 27606 Tel. (919) 851-6866 Fax. (919) 851-7024 www.stantec.com License No. F-0672	

NAD 83 NC GRID

21+00

22+00

23+00

24+00

MATCHLINE -L- STA. 20+60 SEE SHEET 4

MATCHLINE -L- STA. 24+20 SEE SHEET 6

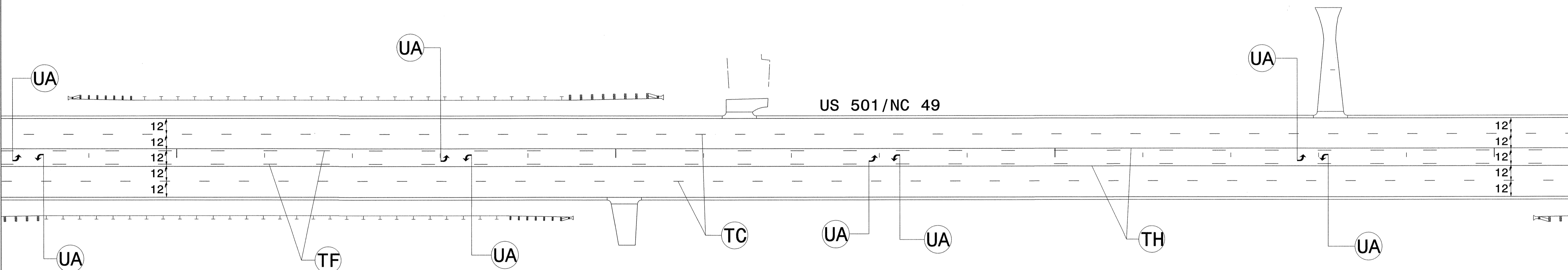

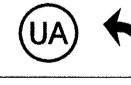
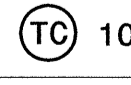
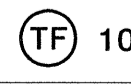
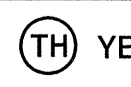
THERMOPLASTIC PAVEMENT MARKING LEGEND	
 LEFT TURN ARROW	 10 FT WHITE SKIP (4")
	 10 FT YELLOW SKIP (4")
	 YELLOW SINGLE CENTER (4")

PAVEMENT MARKING DETAIL

8/1/2012 10:51:10 AM C:\Users\jwagner\Documents\Projects\2012\2241A\2241A_PMP_05.dgn



TIP NO. R-2241A	SHEET NO. PMP-6
APPROVED: <i>Betsy L. Watson</i>	
DATE: 8/1/12	
SEAL	
<small>Stantec Consulting Services Inc. 801 Jones Franklin Road Suite 300 Raleigh, NC 27606 Tel. (919) 851-6866 Fax. (919) 851-7024 www.stantec.com License No. F-0672</small>	

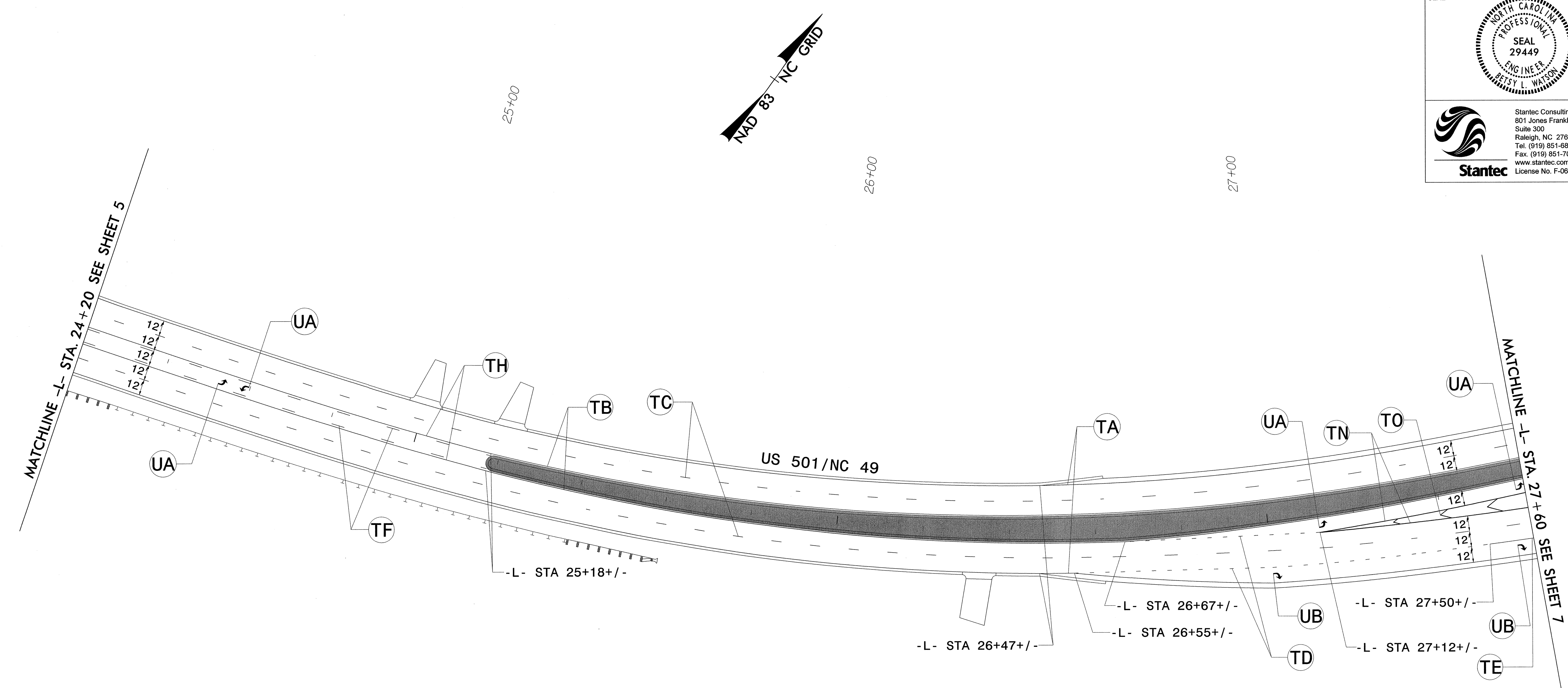

THERMOPLASTIC PAVEMENT MARKING LEGEND	
ⓐ LEFT TURN ARROW	ⓐ WHITE EDGELINE (4")
ⓑ RIGHT TURN ARROW	ⓑ YELLOW EDGELINE (4")
	ⓒ 10 FT WHITE SKIP (4")
	ⓓ 3 FT - 9 FT/SP WHITE MINISKIP (4")
	ⓔ WHITE SOLID LANE LINE (4")
	ⓕ 10 FT YELLOW SKIP (4")
	ⓖ YELLOW SINGLE CENTER (4")
	ⓗ WHITE GORELINE (8")
	ⓓ WHITE DIAGONAL (8")

PAVEMENT MARKING DETAIL

8/1/12
 U:\Projects\2012\Projects\2241A\Plan_Sheets\R2241A_pmp_06.dgn
 J:\Users\jhenning

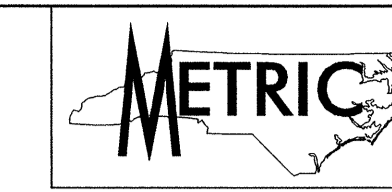

TIP NO. R-2241A	SHEET NO. PMP-7
APPROVED: <i>Betsy L. Watson</i>	
DATE: 8/1/12	
SEAL	
Stantec Consulting Services Inc. 801 Jones Franklin Road Suite 300 Raleigh, NC 27606 Tel. (919) 851-6866 Fax. (919) 851-7024 www.stantec.com License No. F-0672	

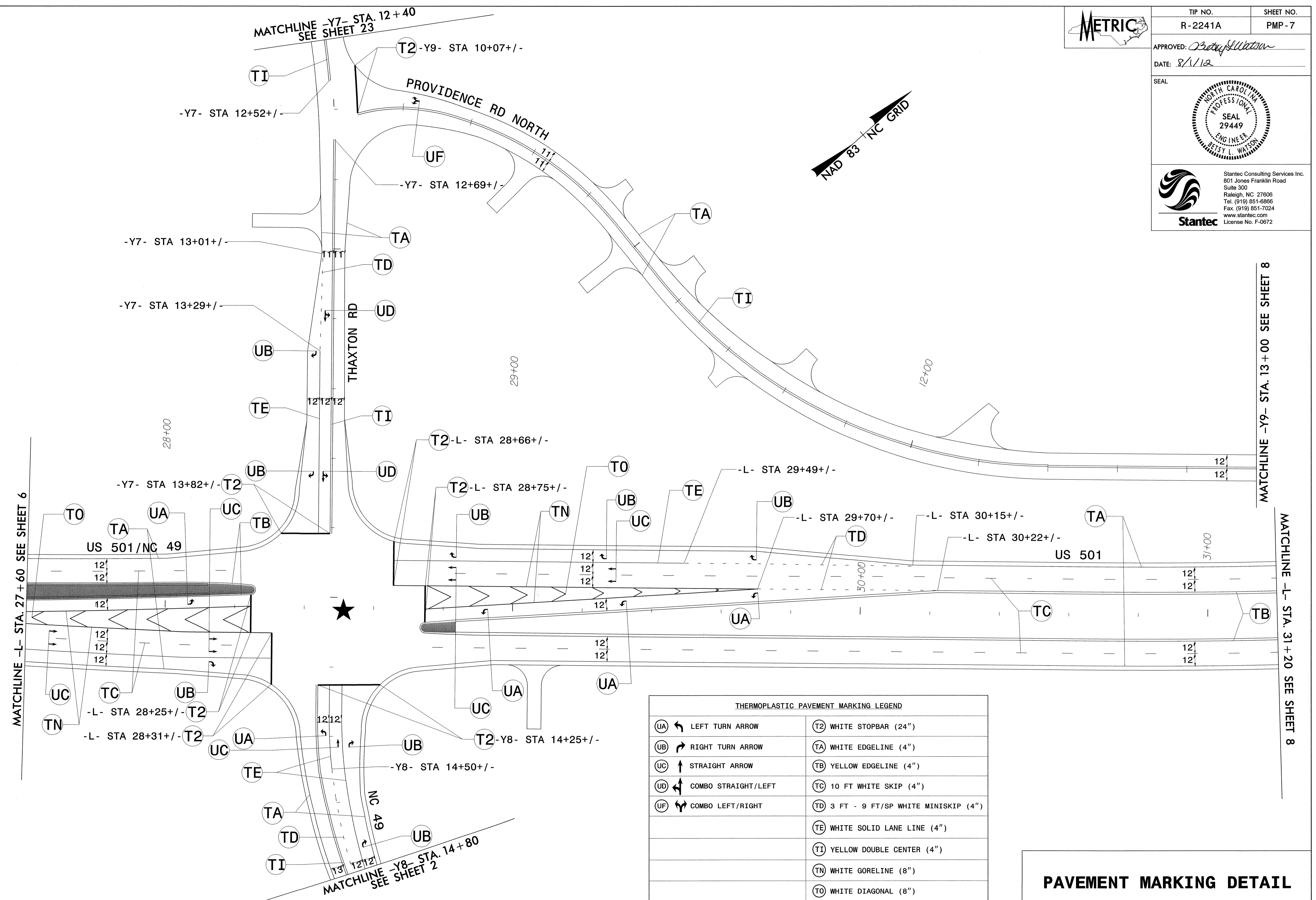

THERMOPLASTIC PAVEMENT MARKING LEGEND	
(UA) ← LEFT TURN ARROW	(T2) WHITE STOPBAR (24")
(UB) → RIGHT TURN ARROW	(TA) WHITE EDGELINE (4")
(UC) ↑ STRAIGHT ARROW	(TB) YELLOW EDGELINE (4")
(UD) ↙ COMBO STRAIGHT/LEFT	(TC) 10 FT WHITE SKIP (4")
(UF) ↘ COMBO LEFT/RIGHT	(TD) 3 FT - 9 FT/SP WHITE MINISKIP (4")
	(TE) WHITE SOLID LANE LINE (4")
	(TI) YELLOW DOUBLE CENTER (4")
	(TN) WHITE GORELINE (8")
	(TO) WHITE DIAGONAL (8")

PAVEMENT MARKING DETAIL

8/1/2012 10:53:03 AM \\s:\gms\pavement\Marking\Plan\Plan_Sheets\R2241A_pmp_07.dgn

METRIC

TIP NO. R-2241A	SHEET NO. PMP-8
--------------------	--------------------

APPROVED: *Betsy L. Watson*
 DATE: 8/1/12

SEAL

Stantec Consulting Services Inc.
 801 Jones Franklin Road
 Suite 300
 Raleigh, NC 27606
 Tel. (919) 851-6866
 Fax. (919) 851-7024
 www.stantec.com
 License No. F-0572

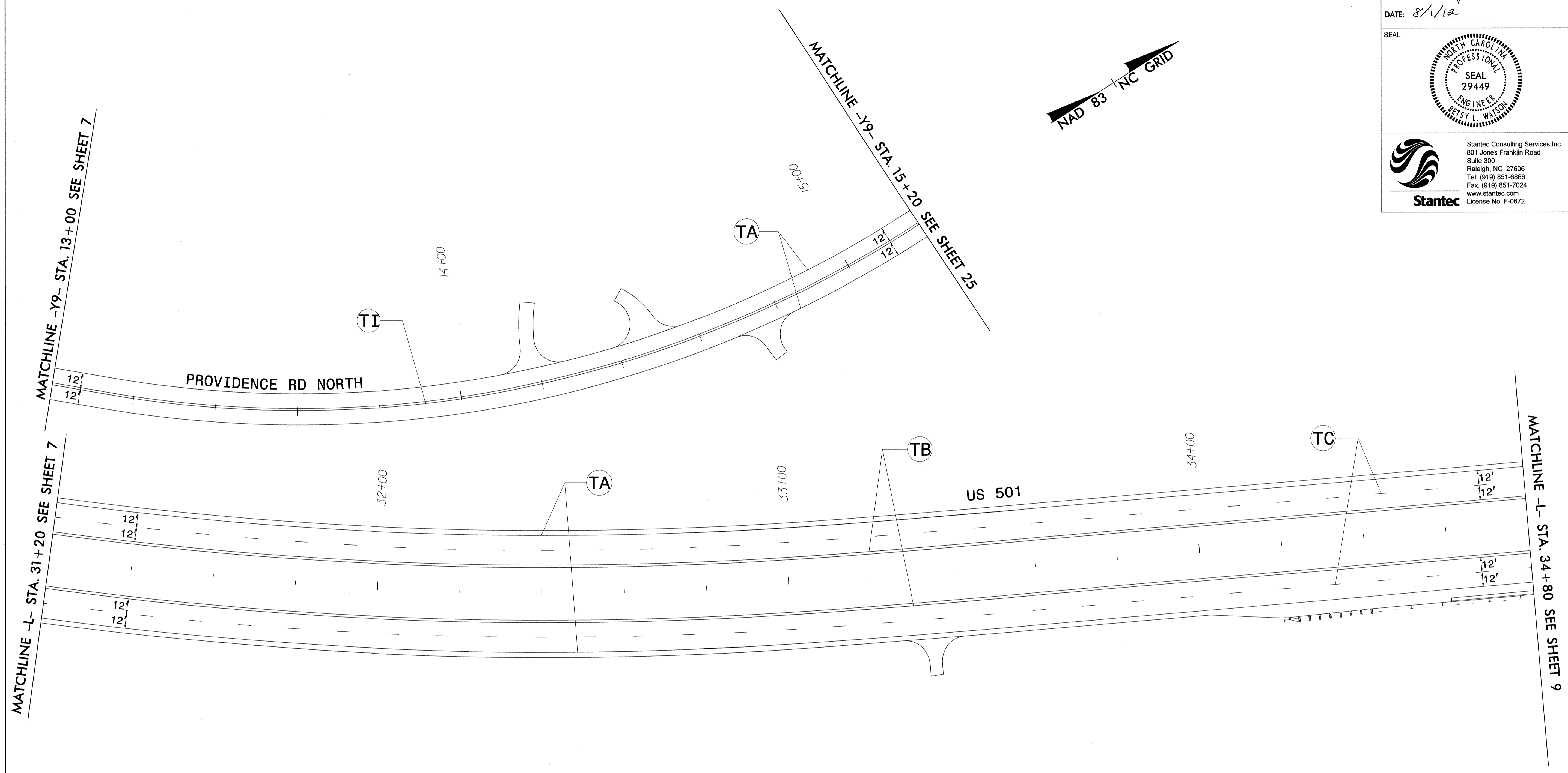
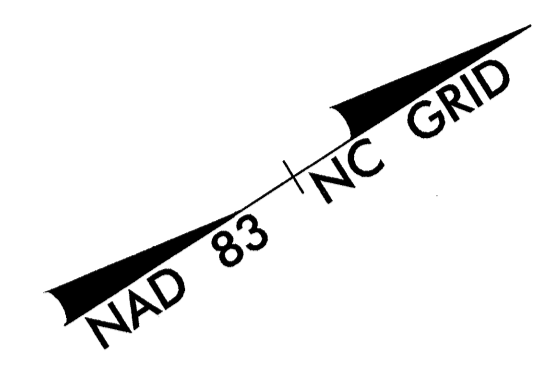

THERMOPLASTIC PAVEMENT MARKING LEGEND

(TA)	WHITE EDGELINE (4")
(TB)	YELLOW EDGELINE (4")
(TC)	10 FT WHITE SKIP (4")
(TI)	YELLOW DOUBLE CENTER (4")

PAVEMENT MARKING DETAIL

8/1/2012 10:53:12 AM C:\Users\jwatson\Documents\Projects\Plan\Plan Sheets\R2241A_pmp_08.dgn

METRIC

TIP NO. R-2241A	SHEET NO. PMP-9
--------------------	--------------------

APPROVED: *Betsy L. Watson*
 DATE: 8/1/12

SEAL

Stantec Consulting Services Inc.
 801 Jones Franklin Road
 Suite 300
 Raleigh, NC 27606
 Tel. (919) 851-6866
 Fax. (919) 851-7024
 www.stantec.com
 License No. F-0672

Stantec

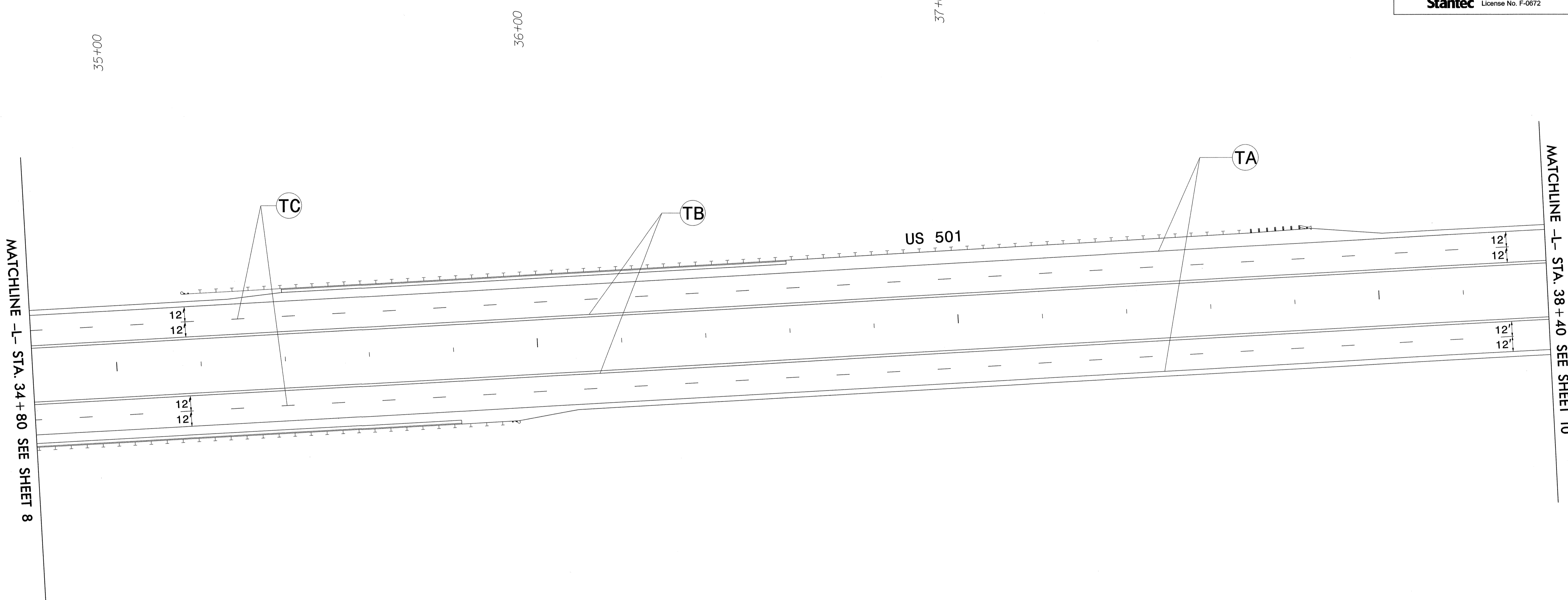
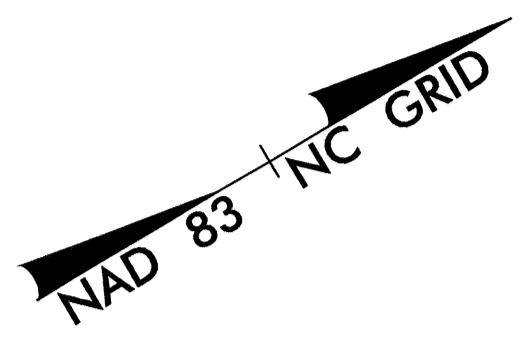



THERMOPLASTIC PAVEMENT MARKING LEGEND	
(TA)	WHITE EDGELINE (4")
(TB)	YELLOW EDGELINE (4")
(TC)	10 FT WHITE SKIP (4")

PAVEMENT MARKING DETAIL

8/1/2012 10:51:00 AM C:\Users\jwatson\Documents\Projects\2241A\Plan Sheets\R2241A_pmp_09.dgn



TIP NO. R-2241A	SHEET NO. PMP-10
APPROVED <i>Betsy L. Watson</i>	
DATE: 8/1/12	
SEAL	
	
	
Stantec Consulting Services Inc. 801 Jones Franklin Road Suite 300 Raleigh, NC 27606 Tel. (919) 851-6866 Fax. (919) 851-7024 www.stantec.com License No. F-0672	

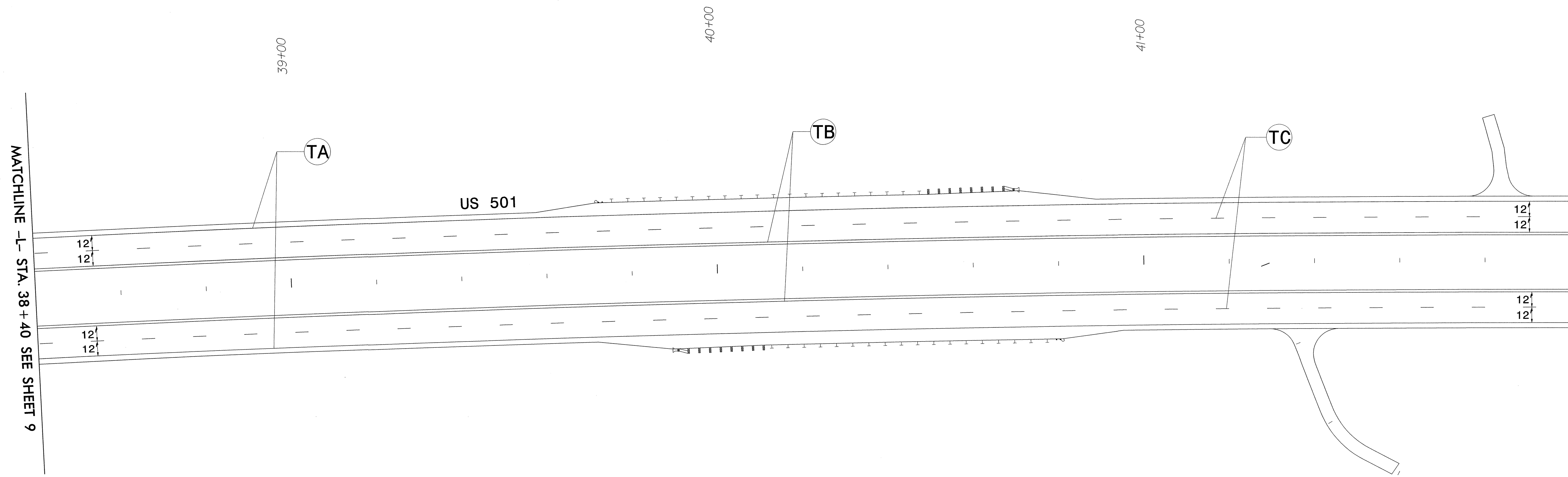
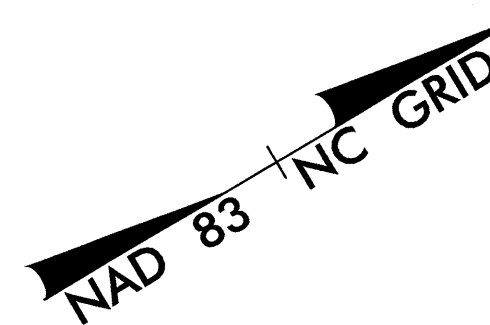

THERMOPLASTIC PAVEMENT MARKING LEGEND	
(TA)	WHITE EDGELINE (4")
(TB)	YELLOW EDGELINE (4")
(TC)	10 FT WHITE SKIP (4")

PAVEMENT MARKING DETAIL

8/1/2012 10:51:10 AM \\s:\signing\pavement\Marking\Plan\Plan_Sheets\VR2241A_pmp_10.dgn

METRIC

TIP NO. R-2241A SHEET NO. PMP-11

APPROVED: *Betsy L. Watson*

DATE: 8/1/12

SEAL

Stantec Consulting Services Inc.
801 Jones Franklin Road
Suite 300
Raleigh, NC 27606
Tel. (919) 851-6866
Fax. (919) 851-7024
www.stantec.com
License No. F-0572

Stantec

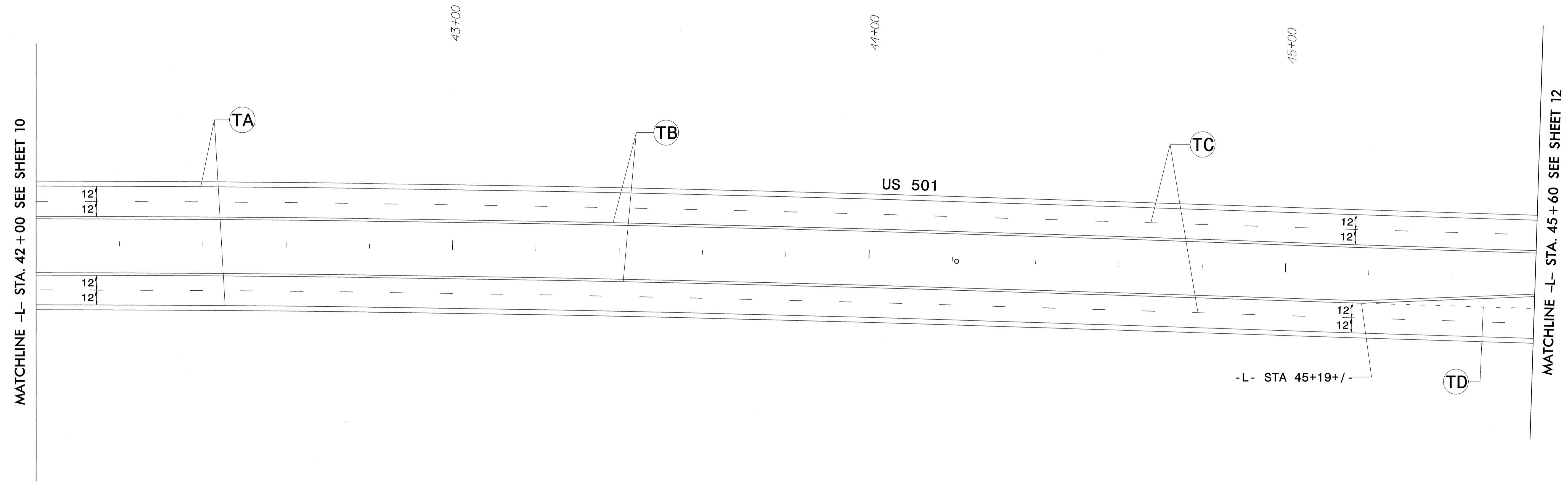
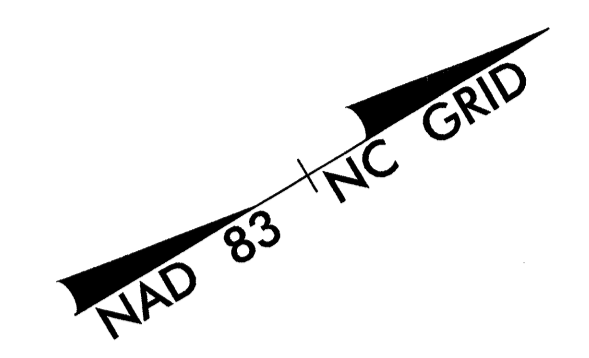

THERMOPLASTIC PAVEMENT MARKING LEGEND	
(TA)	WHITE EDGELINE (4")
(TB)	YELLOW EDGELINE (4")
(TC)	10 FT WHITE SKIP (4")
(TD)	3 FT - 9 FT/SP WHITE MINISKIP (4")

PAVEMENT MARKING DETAIL

8/1/2012 1:58:10 PM \\serving\pavement\marking\plan\plan_sheets\MP241A_pmp-11.dgn

METRIC

TIP NO. R-2241A SHEET NO. PMP-12

APPROVED: *Betsy L. Watson*

DATE: 8/1/12

SEAL

Stantec Consulting Services Inc.
801 Jones Franklin Road
Suite 300
Raleigh, NC 27606
Tel. (919) 851-6866
Fax. (919) 851-7024
www.stantec.com
License No. F-0672

MATCHLINE -L- STA. 45+60 SEE SHEET 11

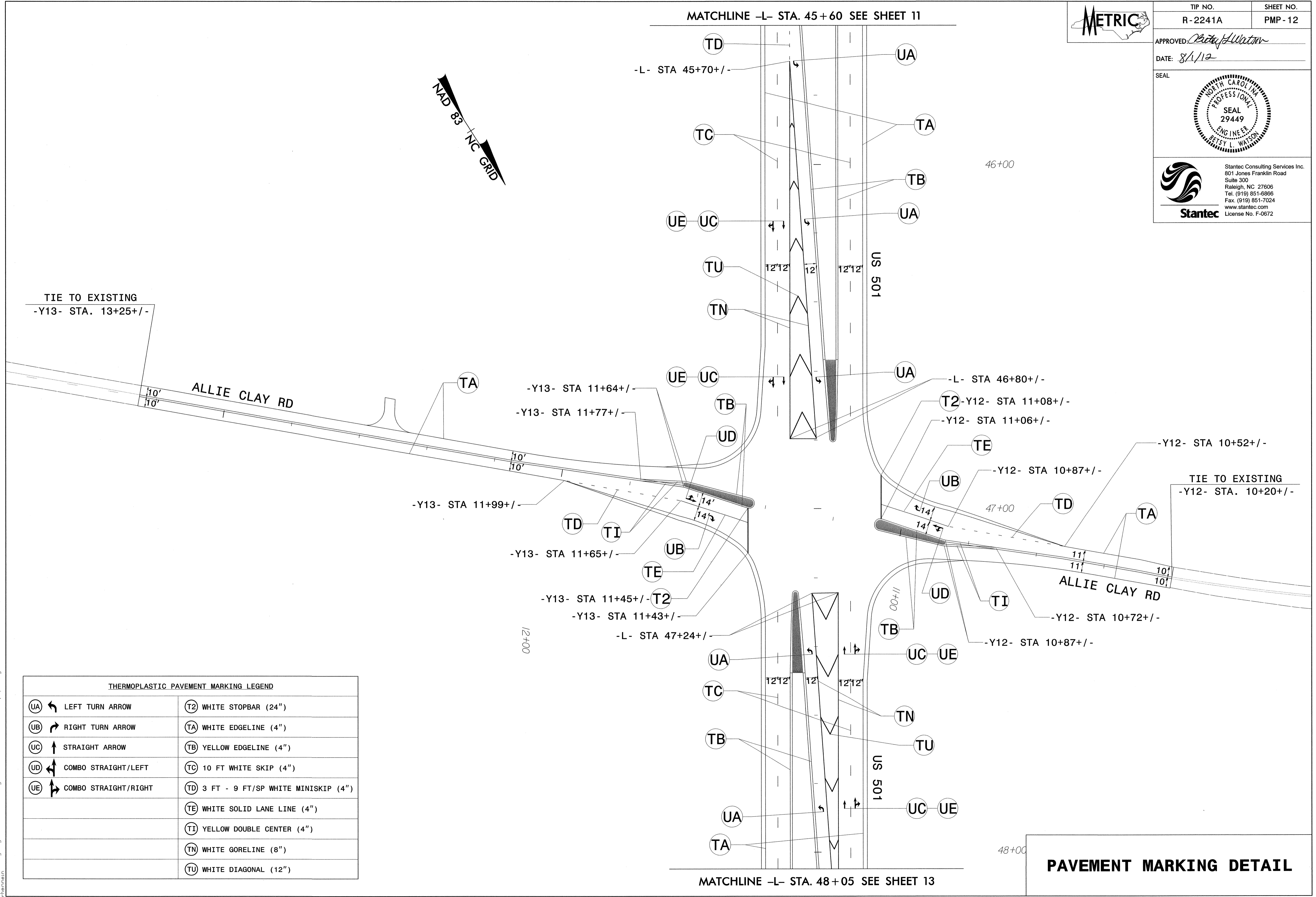
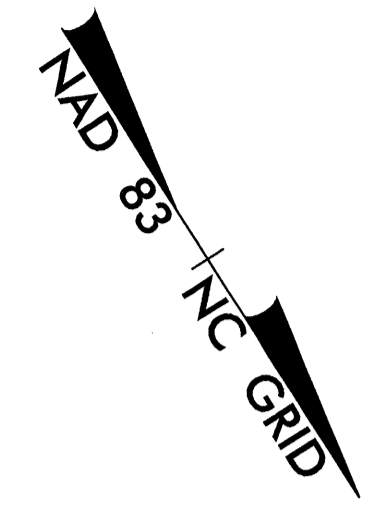

TIE TO EXISTING
-Y13- STA. 13+25+/-

TIE TO EXISTING
-Y12- STA. 10+20+/-

THERMOPLASTIC PAVEMENT MARKING LEGEND			
UA	LEFT TURN ARROW	T2	WHITE STOPBAR (24")
UB	RIGHT TURN ARROW	TA	WHITE EDGELINE (4")
UC	STRAIGHT ARROW	TB	YELLOW EDGELINE (4")
UD	COMBO STRAIGHT/LEFT	TC	10 FT WHITE SKIP (4")
UE	COMBO STRAIGHT/RIGHT	TD	3 FT - 9 FT/SP WHITE MINISKIP (4")
		TE	WHITE SOLID LANE LINE (4")
		TI	YELLOW DOUBLE CENTER (4")
		TN	WHITE GORELINE (8")
		TU	WHITE DIAGONAL (12")

MATCHLINE -L- STA. 48+05 SEE SHEET 13

PAVEMENT MARKING DETAIL

8/1/2012 10:51:12 AM C:\Users\pmp12\Documents\Projects\2241A\Drawings\Sheet\RF2241A_pmp12.dgn



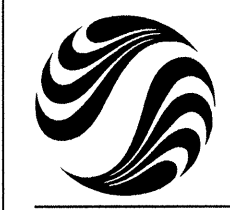

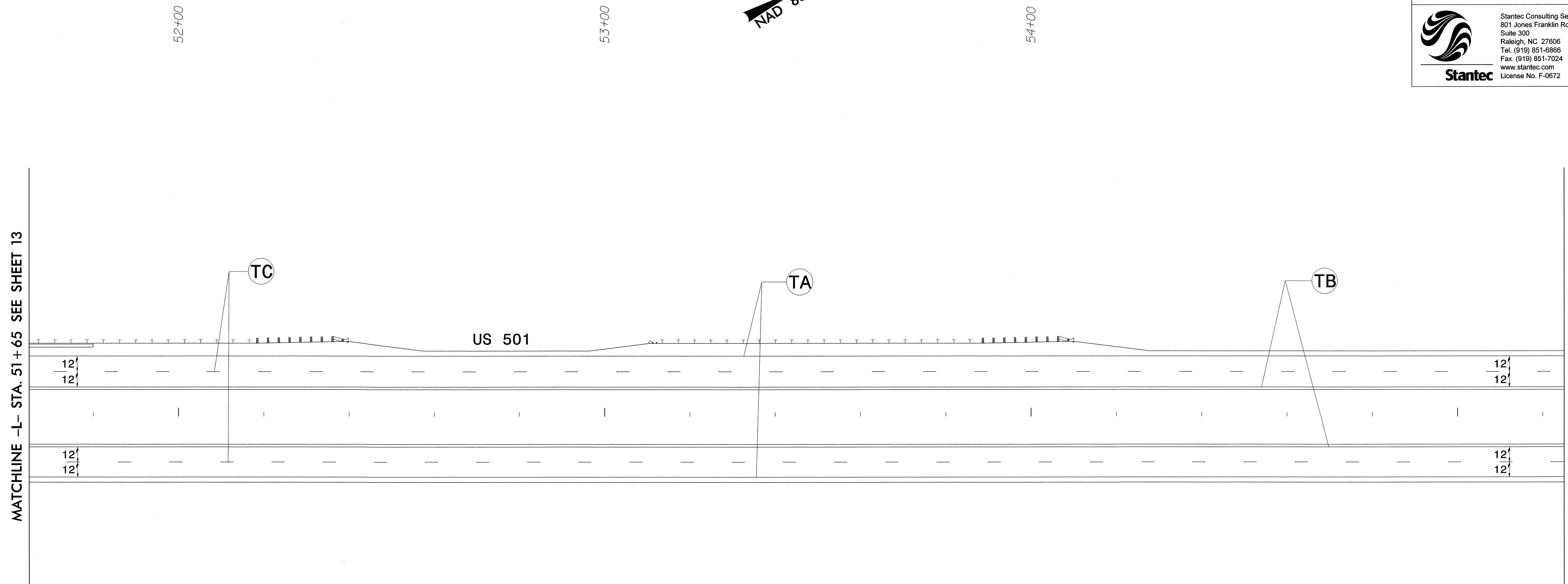
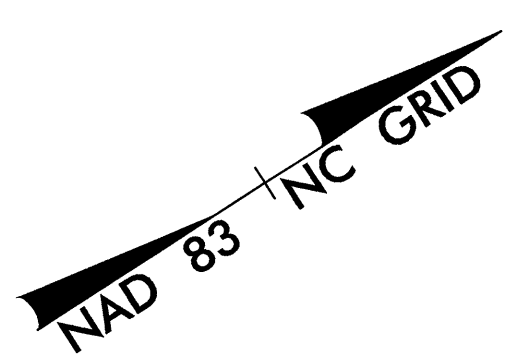
TIP NO. R-2241A	SHEET NO. PMP-14
APPROVED: <i>Betsy L. Watson</i>	
DATE: 8/1/12	
SEAL	
	
	
Stantec Consulting Services Inc. 801 Jones Franklin Road Suite 300 Raleigh, NC 27606 Tel. (919) 851-6866 Fax. (919) 851-7024 www.stantec.com License No. F-0672	



MATCHLINE -L- STA. 51 + 65 SEE SHEET 13

MATCHLINE -L- STA. 55 + 25 SEE SHEET 15

THERMOPLASTIC PAVEMENT MARKING LEGEND	
	WHITE EDGELINE (4")
	YELLOW EDGELINE (4")
	10 FT WHITE SKIP (4")

PAVEMENT MARKING DETAIL

8/1/2012 10:51:00 AM C:\Users\jwatson\Documents\Projects\Plan\Plan Sheets\R2241A_pmp_14.dgn

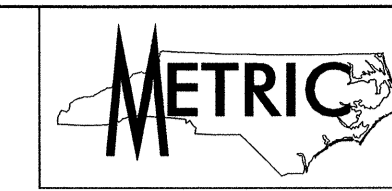

TIP NO. R-2241A	SHEET NO. PMP-15
APPROVED: <i>Petsy L. Watson</i>	
DATE: 8/1/12	
SEAL	
Stantec Consulting Services Inc. 801 Jones Franklin Road Suite 300 Raleigh, NC 27606 Tel. (919) 851-6866 Fax. (919) 851-7024 www.stantec.com License No. F-0672	

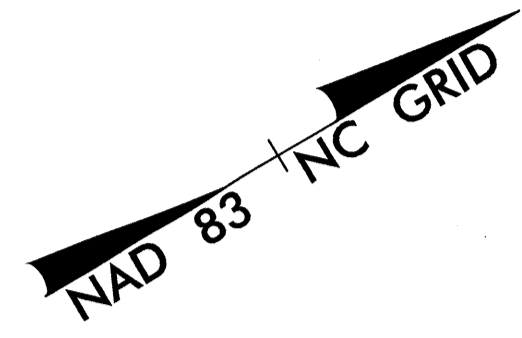

56+00

57+00

58+00

MATCHLINE -L- STA. 55 + 25 SEE SHEET 14

MATCHLINE -L- STA. 58 + 85 SEE SHEET 16

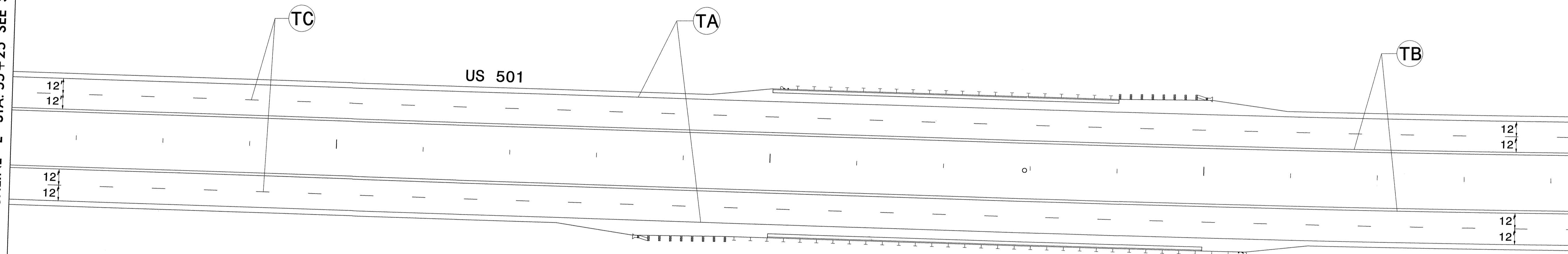

THERMOPLASTIC PAVEMENT MARKING LEGEND	
(TA)	WHITE EDGELINE (4")
(TB)	YELLOW EDGELINE (4")
(TC)	10 FT WHITE SKIP (4")

PAVEMENT MARKING DETAIL

8/1/2012 10:11:15 AM J:\Traffic\Signing\Pavement Marking Plan\Plan Sheets\R2241A.pmp_15.dgn

METRIC

TIP NO. R-2241A SHEET NO. PMP-16

APPROVED: *Betsy L. Watson*

DATE: 8/1/12

SEAL

Stantec Consulting Services Inc.
801 Jones Franklin Road
Suite 300
Raleigh, NC 27606
Tel. (919) 851-6866
Fax. (919) 851-7024
www.stantec.com
License No. F-0672

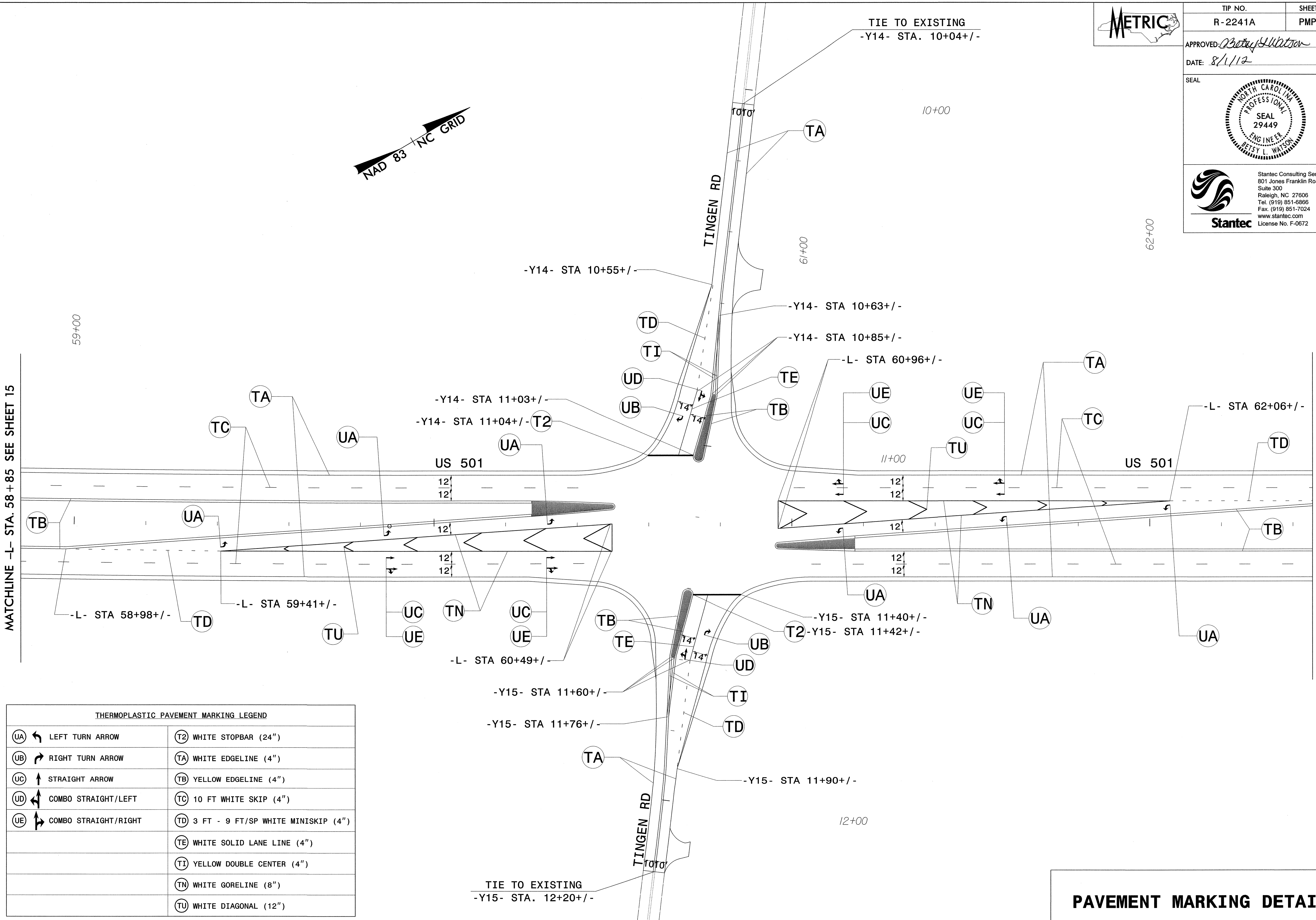
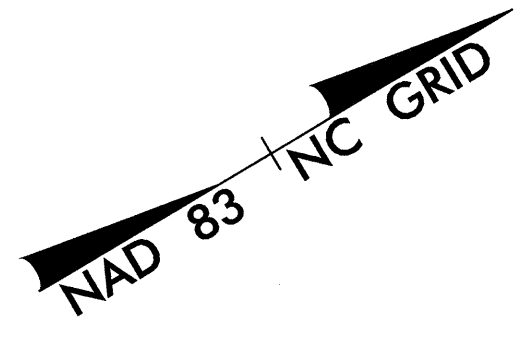

THERMOPLASTIC PAVEMENT MARKING LEGEND			
(UA) ←	LEFT TURN ARROW	(T2) [Symbol]	WHITE STOPBAR (24")
(UB) →	RIGHT TURN ARROW	(TA) [Symbol]	WHITE EDGELINE (4")
(UC) ↑	STRAIGHT ARROW	(TB) [Symbol]	YELLOW EDGELINE (4")
(UD) ↙	COMBO STRAIGHT/LEFT	(TC) [Symbol]	10 FT WHITE SKIP (4")
(UE) ↘	COMBO STRAIGHT/RIGHT	(TD) [Symbol]	3 FT - 9 FT/SP WHITE MINISKIP (4")
		(TE) [Symbol]	WHITE SOLID LANE LINE (4")
		(TI) [Symbol]	YELLOW DOUBLE CENTER (4")
		(TN) [Symbol]	WHITE GORELINE (8")
		(TU) [Symbol]	WHITE DIAGONAL (12")

PAVEMENT MARKING DETAIL

8/1/2012 9:15:10 AM C:\Users\jwatson\Documents\Projects\2241A\Drawings\Plan\Plan_Sheets\2241A_pmp_16.dgn



TIP NO.

R-2241A

SHEET NO.

PMP-17

APPROVED *Betsy L. Watson*

DATE: 8/1/12

SEAL



Stantec Consulting Services Inc.
801 Jones Franklin Road
Suite 300
Raleigh, NC 27606
Tel. (919) 851-8866
Fax. (919) 851-7024
www.stantec.com
License No. F-0672

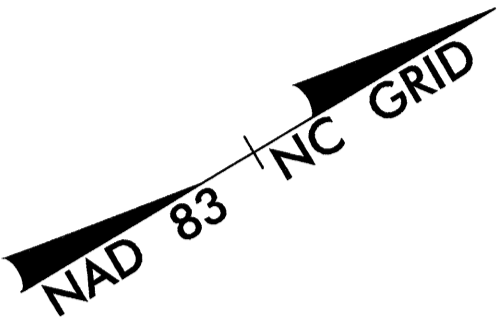

63+00

64+00

65+00

MATCHLINE -L- STA. 62 + 45 SEE SHEET 16

MATCHLINE -L- STA. 66 + 05 SEE SHEET 18

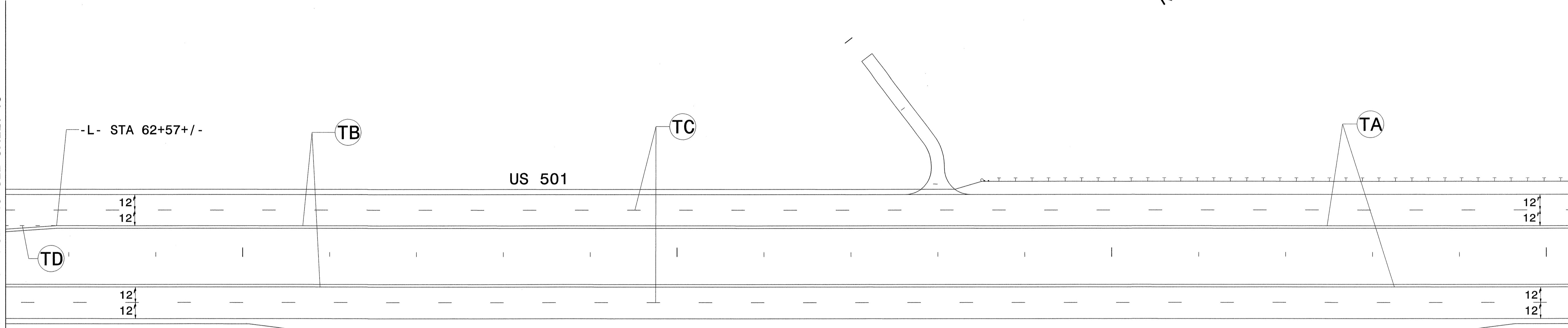

-L- STA 62+57+/-

US 501

12'
12'

12'
12'

12'
12'

12'
12'

TIE TO EXISTING
-Y16- STA. 10+96 +/-

HALIFAX RD

THERMOPLASTIC PAVEMENT MARKING LEGEND	
(TA)	WHITE EDGELINE (4")
(TB)	YELLOW EDGELINE (4")
(TC)	10 FT WHITE SKIP (4")
(TD)	3 FT - 9 FT/SP WHITE MINISKIP (4")

PAVEMENT MARKING DETAIL

8/1/2012 10:51:11 AM \\s:\signing\pavement\marking\plan\plan Sheets\R2241A\pmp_17.dgn

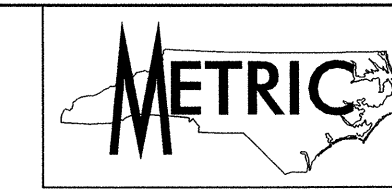

TIP NO. R-2241A	SHEET NO. PMP-18
APPROVED: <i>Betsy L. Watson</i>	
DATE: 8/1/12	
SEAL	
<small>Stantec Consulting Services Inc. 801 Jones Franklin Road Suite 300 Raleigh, NC 27606 Tel. (919) 851-6866 Fax. (919) 851-7024 www.stantec.com License No. F-0672</small>	

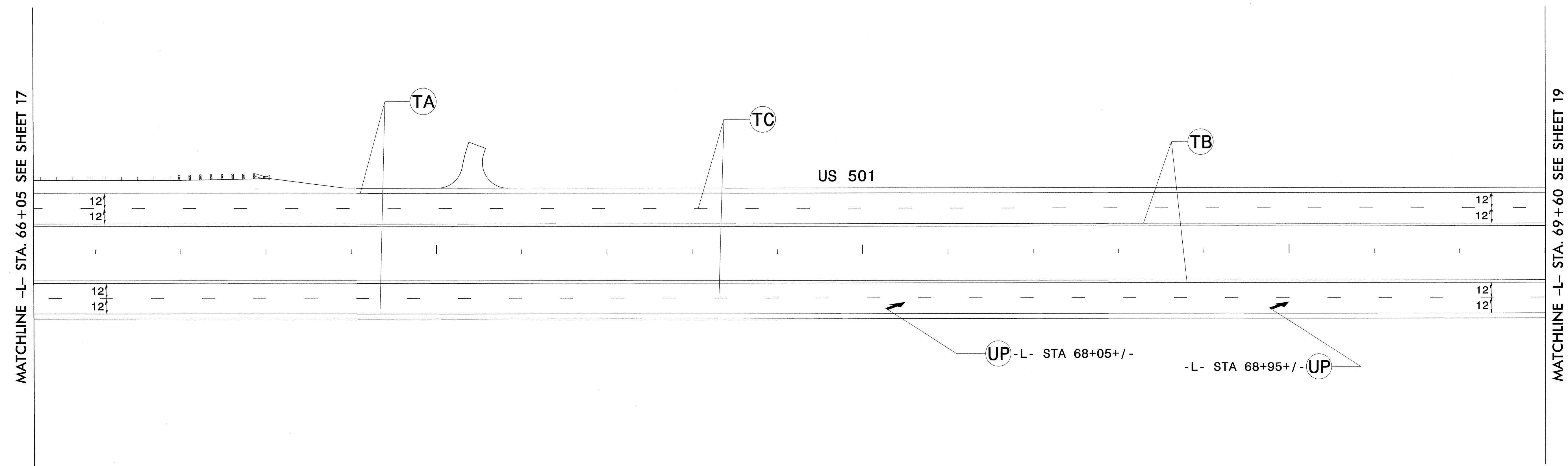
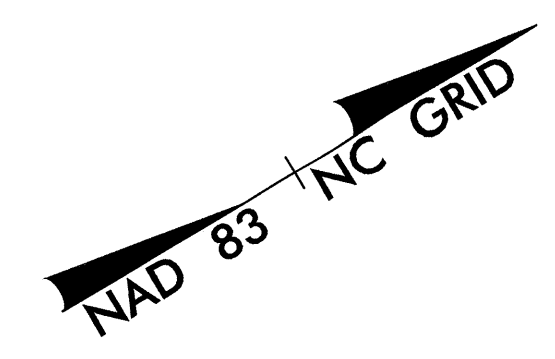

THERMOPLASTIC PAVEMENT MARKING LEGEND	
MERGE ARROW	WHITE EDGELINE (4")
	YELLOW EDGELINE (4")
	10 FT WHITE SKIP (4")

PAVEMENT MARKING DETAIL

8/1/2012 10:00 AM C:\Users\jason\Documents\Projects\Stantec\Projects\2241A\pmp_18.dgn



TIP NO. R-2241A SHEET NO. PMP-19

APPROVED: *Betsy Watson*
DATE: 2/19/13

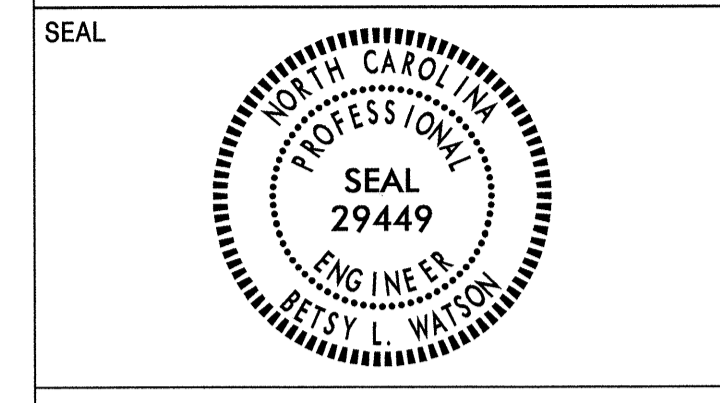

Stantec
Stantec Consulting Services Inc.
801 Jones Franklin Road
Suite 300
Raleigh, NC 27606
Tel. (919) 851-8866
Fax. (919) 851-7024
www.stantec.com
License No. F-0872

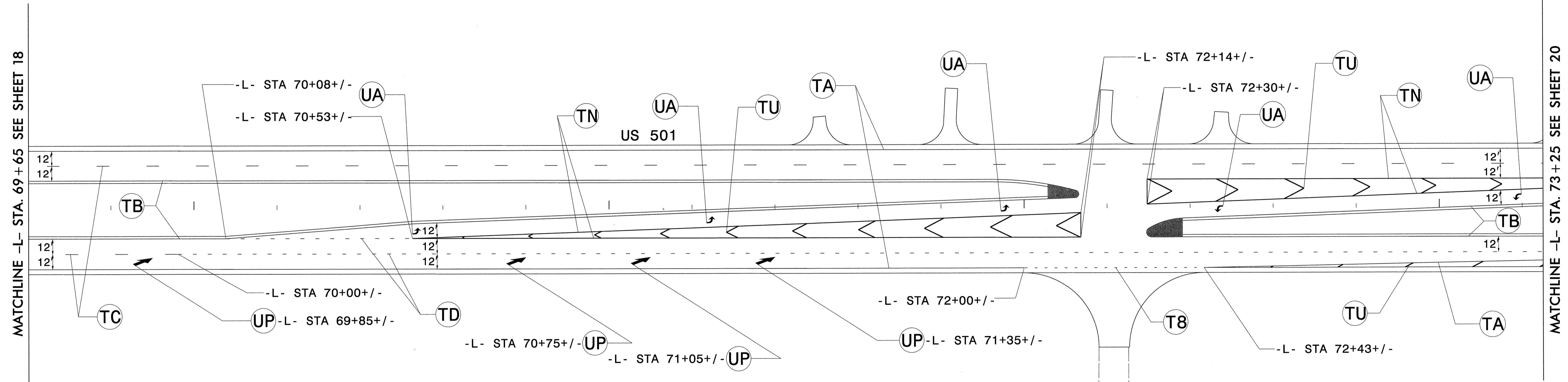
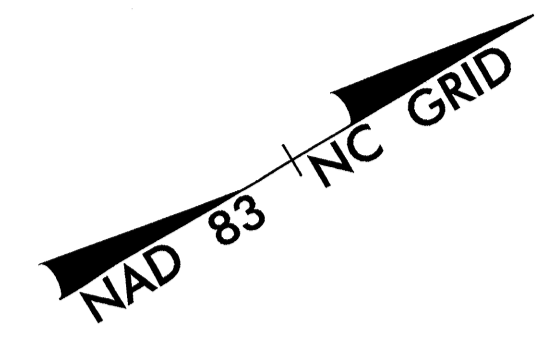

THERMOPLASTIC PAVEMENT MARKING LEGEND			
(UA) ←	LEFT TURN ARROW	(TB)	2 FT - 6 FT/SP WHITE MINISKIP (4")
(UP) ↑	MERGE ARROW	(TA)	WHITE EDGELINE (4")
		(TB)	YELLOW EDGELINE (4")
		(TC)	10 FT WHITE SKIP (4")
		(TD)	3 FT - 9 FT/SP WHITE MINISKIP (4")
		(TN)	WHITE GORELINE (8")
		(TU)	WHITE DIAGONAL (12")

PAVEMENT MARKING DETAIL

2/19/13
 L:\Projects\2013\Stantec\Projects\Stantec\Plan\Plan_Sheets\R2241A.pmp.19.dgn
 Berman

THERMOPLASTIC PAVEMENT MARKING LEGEND			
(UA) ←	LEFT TURN ARROW	(T2)	WHITE STOPBAR (24")
(UB) ↗	RIGHT TURN ARROW	(TA)	WHITE EDGELINE (4")
(UC) ↑	STRAIGHT ARROW	(TB)	YELLOW EDGELINE (4")
		(TC)	10 FT WHITE SKIP (4")
		(TD)	3 FT - 9 FT/SP WHITE MINISKIP (4")
		(TE)	WHITE SOLID LANE LINE (4")
		(TI)	YELLOW DOUBLE CENTER (4")
		(TN)	WHITE GORELINE (8")
		(TU)	WHITE DIAGONAL (12")
		(TV)	YELLOW DIAGONAL (12")



TIP NO. R-2241A SHEET NO. PMP-20

APPROVED: *Betsy L. Watson*
DATE: 2/19/13

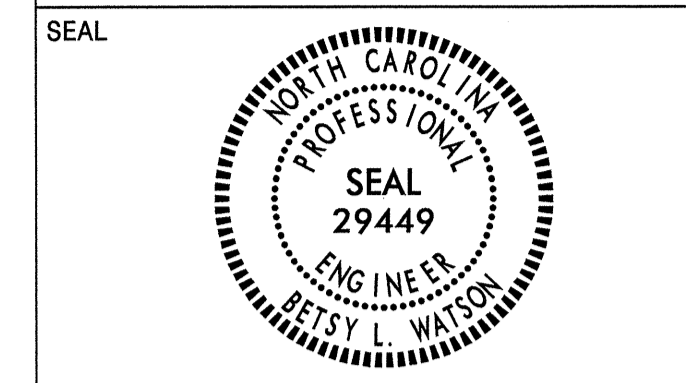

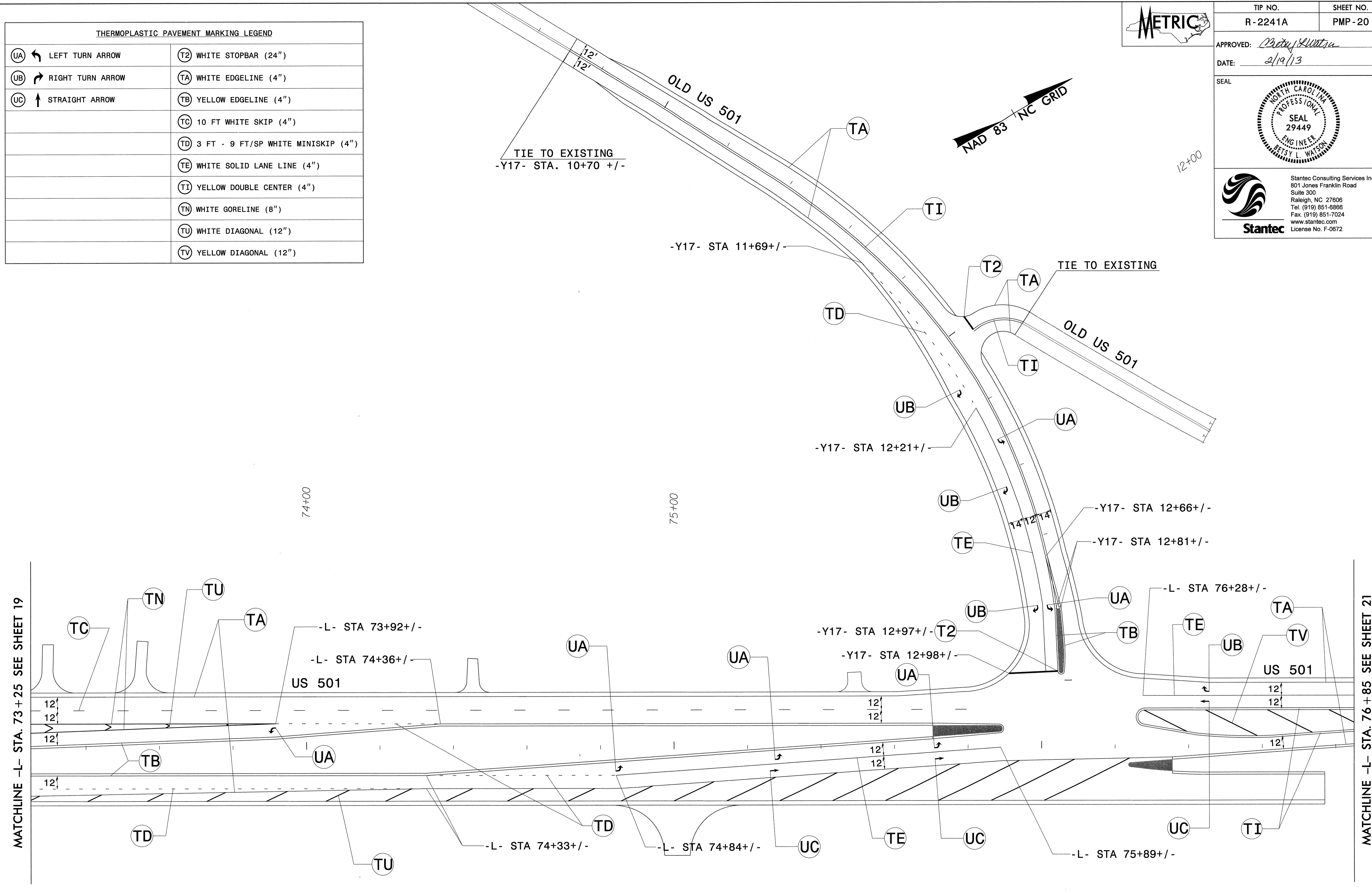

Stantec
Stantec Consulting Services Inc.
801 Jones Franklin Road
Suite 300
Raleigh, NC 27606
Tel. (919) 851-8866
Fax. (919) 851-7024
www.stantec.com
License No. F-0672



PAVEMENT MARKING DETAIL

2/19/2013 10:41:00 AM C:\Users\jwh\Documents\Projects\2241A\pmp_20.dgn



TIP NO. R-2241A	SHEET NO. PMP-21
APPROVED: <i>Betsy L. Watson</i>	
DATE: 8/1/12	
SEAL	
	
	
<small>Stantec Consulting Services Inc. 801 Jones Franklin Road Suite 300 Raleigh, NC 27606 Tel. (919) 851-6866 Fax. (919) 851-7024 www.stantec.com License No. F-0672</small>	

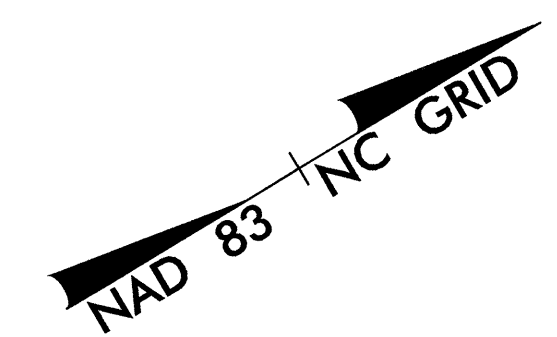

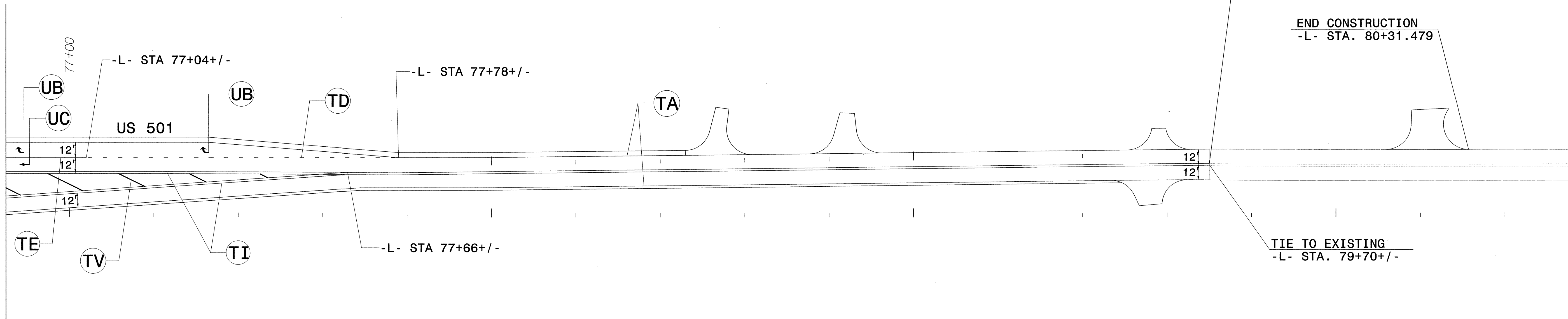

MATCHLINE -L- STA. 76 + 85 SEE SHEET 20



END PAVEMENT MARKING PLAN
R-2241A -L- STA. 79 + 70

END CONSTRUCTION
-L- STA. 80+31.479

TIE TO EXISTING
-L- STA. 79+70+/-

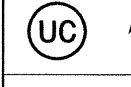
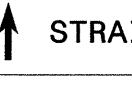
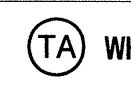
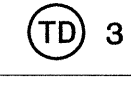
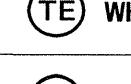
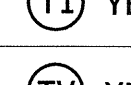
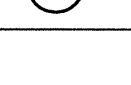
THERMOPLASTIC PAVEMENT MARKING LEGEND	
 	RIGHT TURN ARROW
 	STRAIGHT ARROW
	WHITE EDGELINE (4")
	3 FT - 9 FT/SP WHITE MINISKIP (4")
	WHITE SOLID LANE LINE (4")
	YELLOW DOUBLE CENTER (4")
	YELLOW DIAGONAL (12")

PAVEMENT MARKING DETAIL

8/1/2012 1:58:10 PM C:\Signing\Projects\Marking Plan\Plan Sheets\R2241A.pmp_21.dgn



TIP NO. R-2241A	SHEET NO. PMP-22
--------------------	---------------------

APPROVED: *Betsy L. Watson*
DATE: 8/1/12

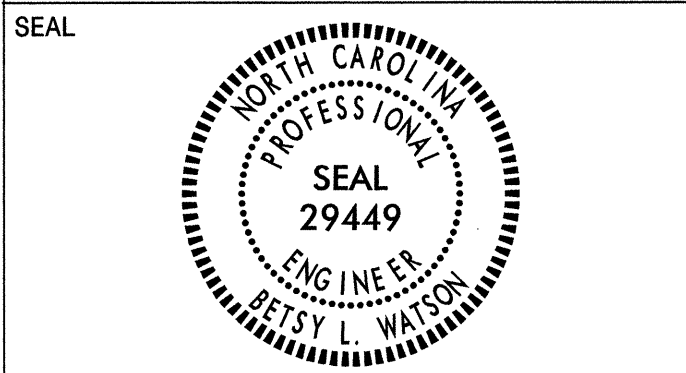

Stantec Stantec Consulting Services Inc.
801 Jones Franklin Road
Suite 300
Raleigh, NC 27606
Tel. (919) 851-6866
Fax. (919) 851-7024
www.stantec.com
License No. F-0672

NAD 83 NC GRID

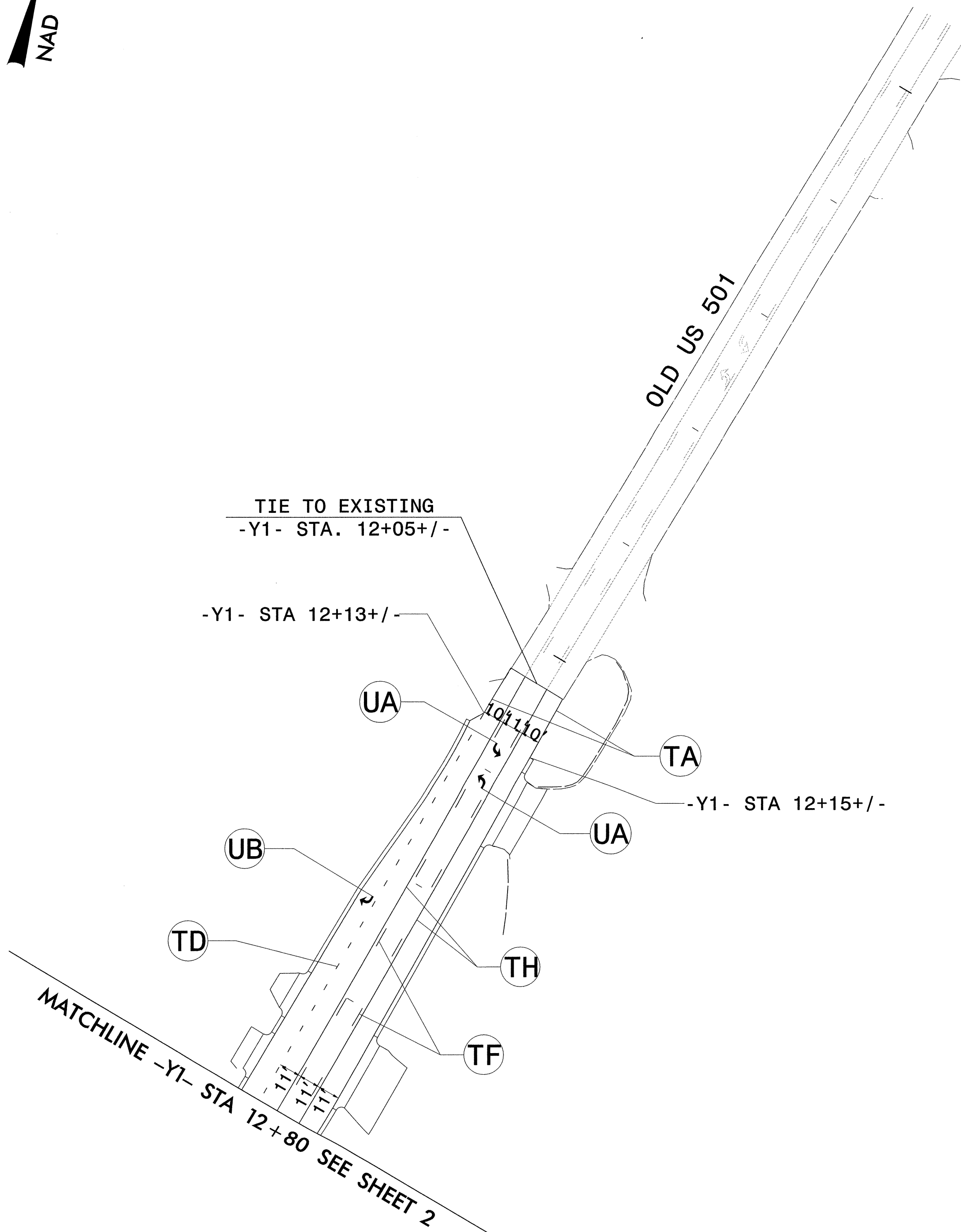

THERMOPLASTIC PAVEMENT MARKING LEGEND	
LEFT TURN ARROW	WHITE EDGELINE (4")
RIGHT TURN ARROW	3 FT - 9 FT/SP WHITE MINISKIP (4")
	10 FT YELLOW SKIP (4")
	YELLOW SINGLE CENTER (4")

PAVEMENT MARKING DETAIL

8/1/2012 10:51:00 AM C:\Users\jwatson\Documents\Projects\Plan\Plan Sheets\R2241A\pmp_22.dgn



TIP NO. R-2241A	SHEET NO. PMP-23
--------------------	---------------------

APPROVED: *Betsy L. Watson*
DATE: 8/1/12



Stantec
Stantec Consulting Services Inc.
801 Jones Franklin Road
Suite 300
Raleigh, NC 27606
Tel. (919) 851-6866
Fax. (919) 851-7024
www.stantec.com
License No. F-0672

NAD 83 NC GRID

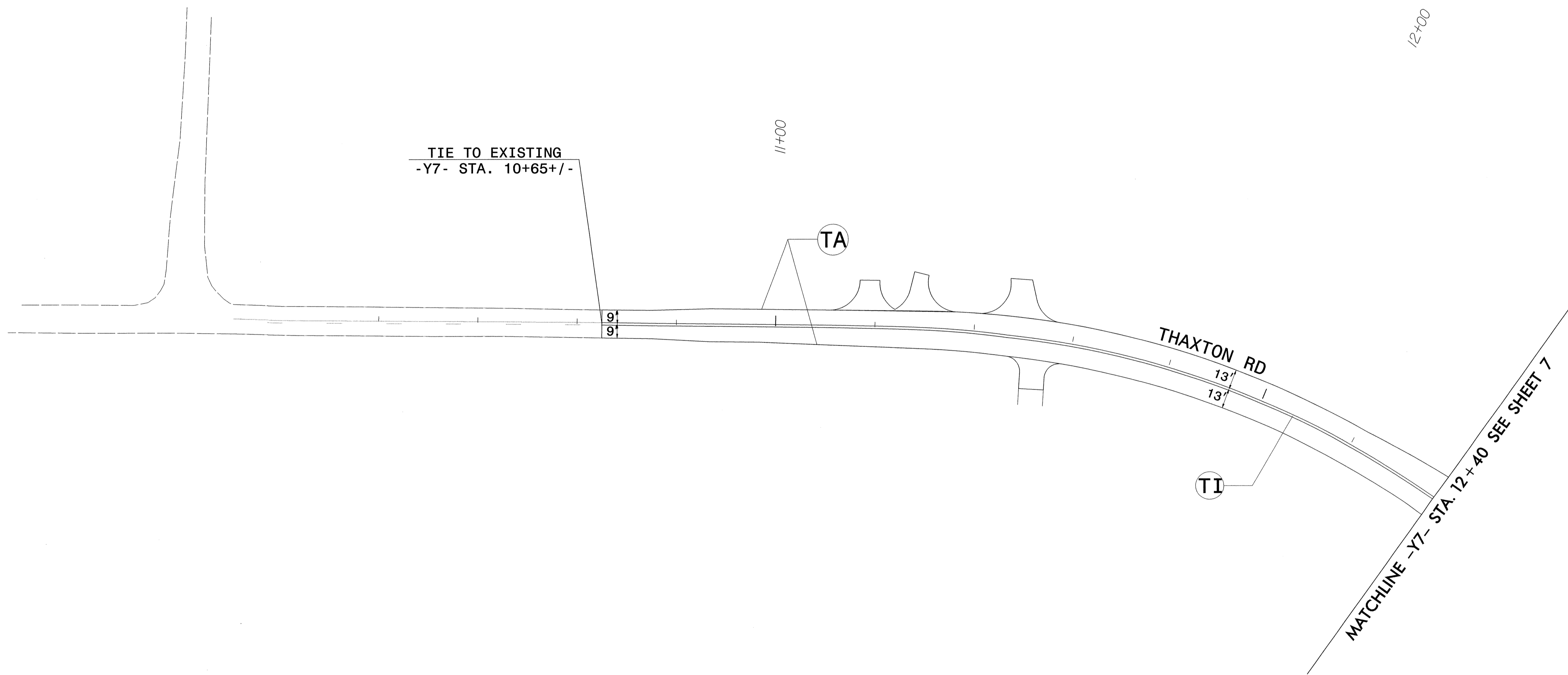

THERMOPLASTIC PAVEMENT MARKING LEGEND	
(TA)	WHITE EDGELINE (4")
(TI)	YELLOW DOUBLE CENTER (4")

PAVEMENT MARKING DETAIL

8/1/2012 10:51:12 AM C:\Users\jwagner\Documents\Projects\2012\2241A\Drawings\Plan\Thaxton Rd\Thaxton Rd - Pavement Marking - PMP-23.dgn



TIP NO. R - 2241A	SHEET NO. PMP - 25
APPROVED <i>Betsy Watson</i>	
DATE: 8/1/12	
SEAL	
	
	
Stantec Consulting Services Inc. 801 Jones Franklin Road Suite 300 Raleigh, NC 27606 Tel. (919) 851-6866 Fax. (919) 851-7024 www.stantec.com License No. F-0672	

NAD 83 NC GRID

MATCHLINE -Y9- STA. 15+20 SEE SHEET 8

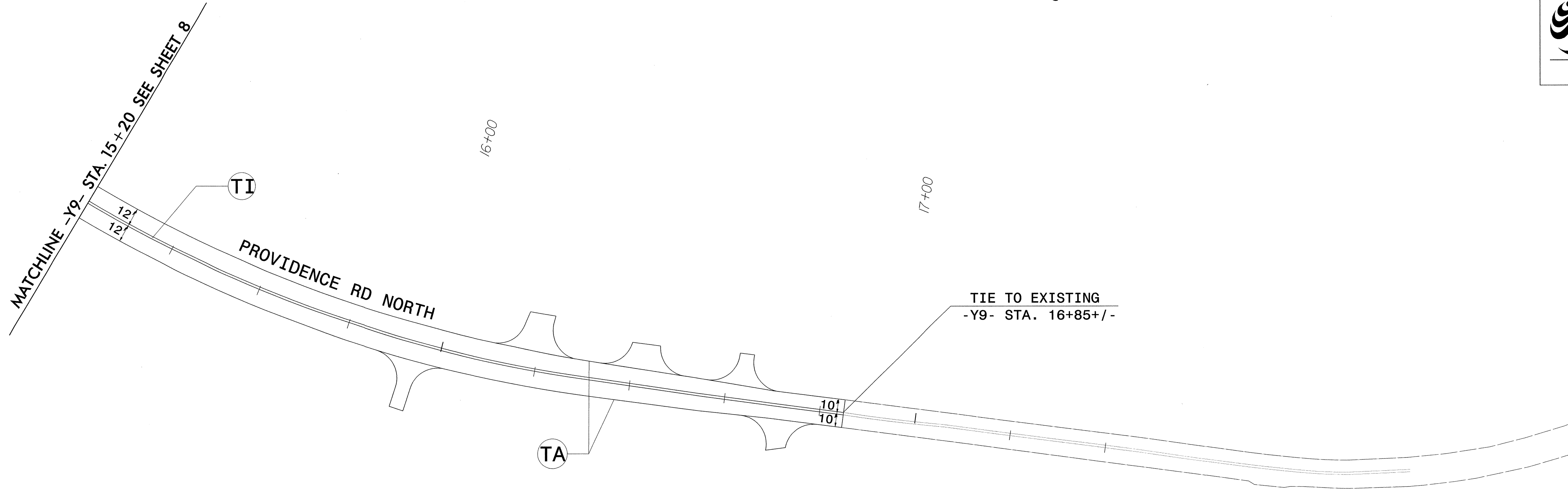

THERMOPLASTIC PAVEMENT MARKING LEGEND	
(TA)	WHITE EDGELINE (4")
(TI)	YELLOW DOUBLE CENTER (4")

PAVEMENT MARKING DETAIL

8/1/2012
 U:\Traffic\Signing\Pavement Marking Plan\Plan Sheets\R2241A_pmp_25.dgn
 bennett