

TIP NO. R-3324	SHEET NO. PMP-1A
APPROVED: <i>[Signature]</i>	
DATE: 11-5-12	
SEAL	
	

STATE OF NORTH CAROLINA
 DEPT. OF TRANSPORTATION
 DIVISION OF HIGHWAYS
 RALEIGH, N.C.

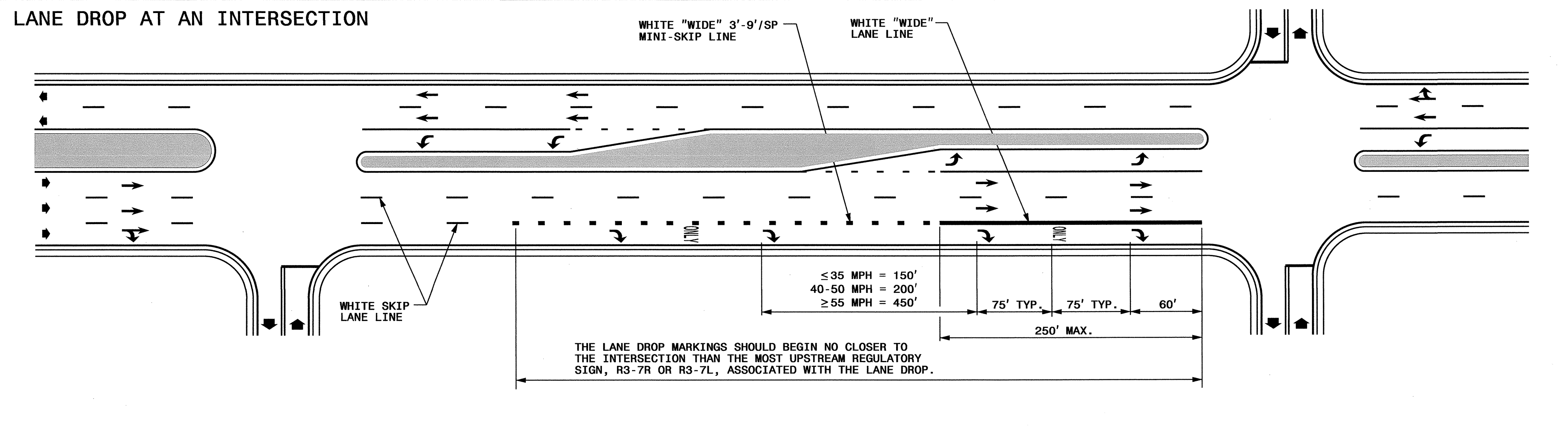

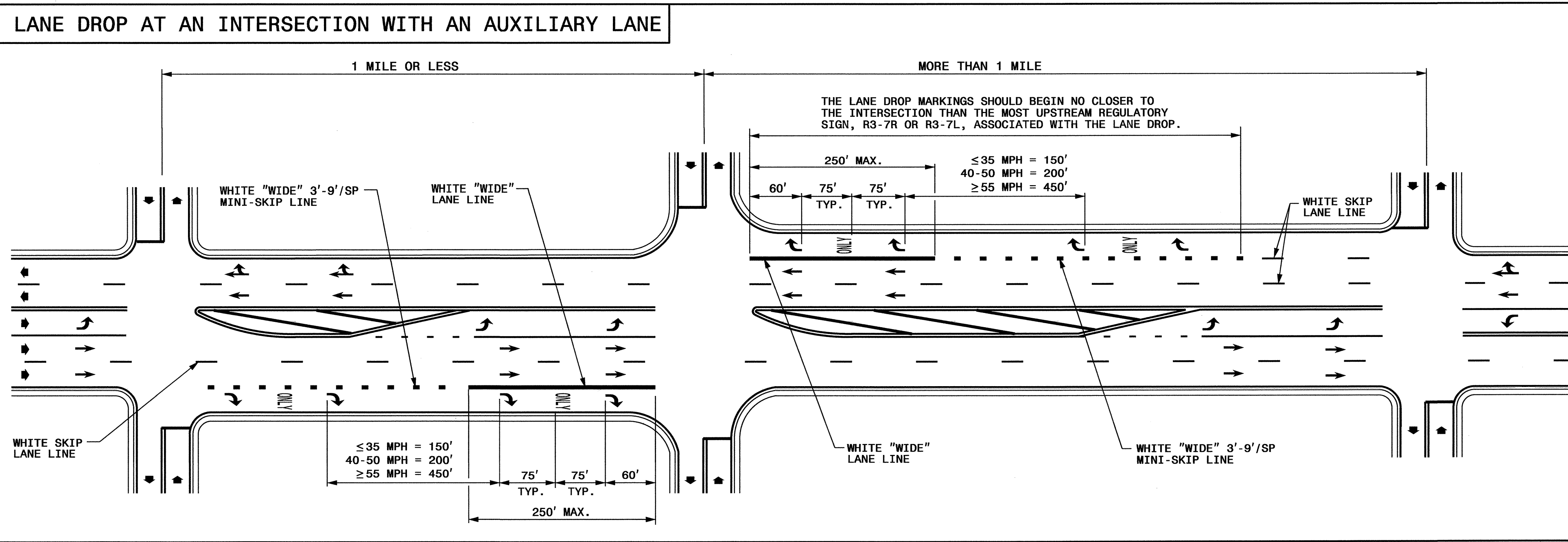

STATE OF NORTH CAROLINA
 DEPT. OF TRANSPORTATION
 DIVISION OF HIGHWAYS
 RALEIGH, N.C.

ENGLISH DETAIL DRAWING FOR
PAVEMENT MARKINGS
 LANE DROPS

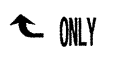

ENGLISH DETAIL DRAWING FOR
PAVEMENT MARKINGS
 LANE DROPS

- GENERAL NOTES:**
- USE THE GUIDANCE SHOWN ON THE ABOVE DETAILS IN CONJUNCTION WITH INTERSECTION GUIDANCE SHOWN ON ROADWAY STANDARD DRAWING 1205.04.
 - LANE LINES INDICATED AS "WIDE" SHALL BE AT LEAST TWICE THE WIDTH OF THE NORMAL LINE.

LEGEND	
W = WIDTH OF TRAVEL LANE	 PAVEMENT MARKING SYMBOLS & CHARACTERS
 DIRECTION OF TRAFFIC FLOW	

SHEET 1 OF 3
1205D06

SHEET 1 OF 3
1205D06

**REVISED PAVEMENT MARKING
ROADWAY STANDARD DRAWING**

02-NOV-2012 11:29
 P:\TIP\Projects\11-103324\Traffic\Signing\CADD\PMPr3324 PM Title Sheet.dgn
 ereward AT 11-24-12

TIP NO. R-3324	SHEET NO. PMP-2
APPROVED: <i>[Signature]</i>	
DATE: 11-5-12	
SEAL	

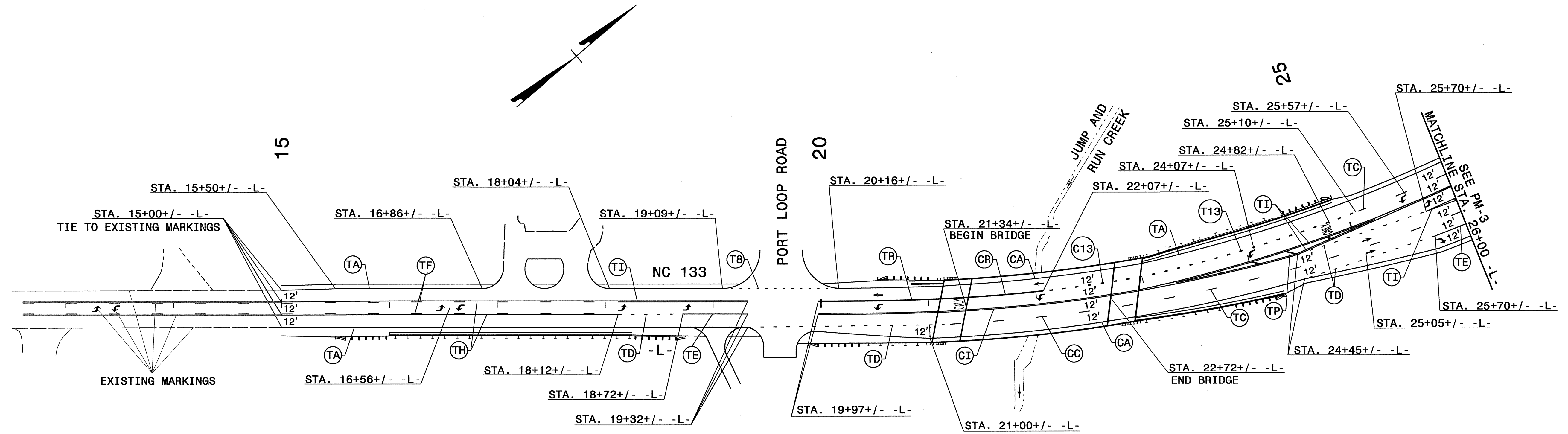

REFER TO RSD NOS. 1205.01, 1205.02, 1205.04, 1205.05, 1205.06, 1205.08, 1205.09, 1205.12, 1205.13, 1250.01, AND 1251.01 FOR PLACEMENT OF FINAL PAVEMENT MARKINGS, SYMBOLS, AND MARKERS UNLESS NOTED OTHERWISE.

SEE PMP-1 FOR PAVEMENT MARKING SCHEDULE

SYMBOL	DESCRIPTION
	DA,UA LEFT TURN ARROW
	UB RIGHT TURN ARROW
	DC,UC STRAIGHT ARROW
ONLY	UI ALPHANUMERIC

PAVEMENT MARKING DETAIL

02-10V-2012 11:30
 E:\PMP\Projects\15-11227905\Traffic\Signing\CADD\PM\3324\pm\pm02_revision.dgn
 AT 11/27/12

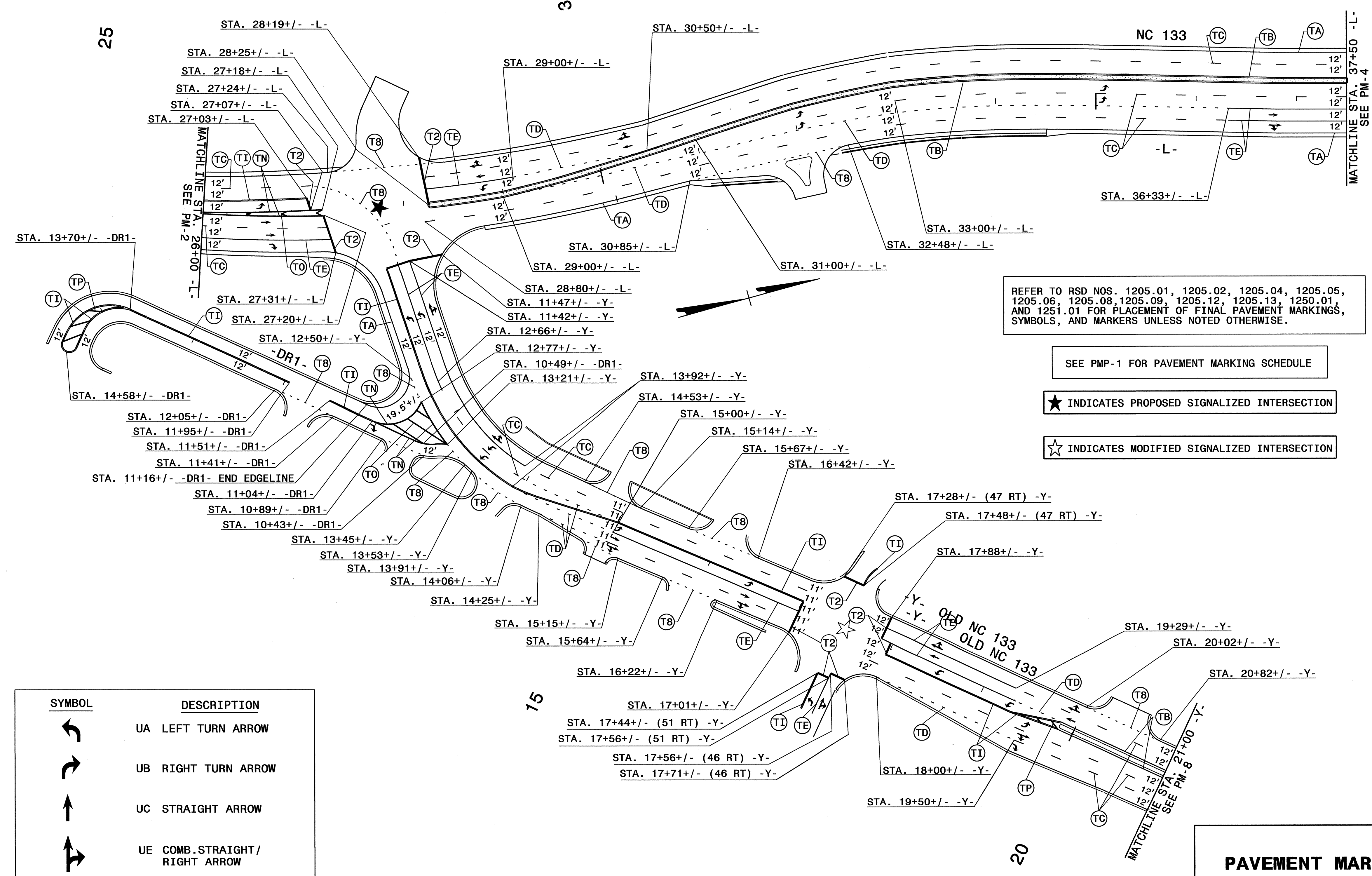

REFER TO RSD NOS. 1205.01, 1205.02, 1205.04, 1205.05, 1205.06, 1205.08, 1205.09, 1205.12, 1205.13, 1250.01, AND 1251.01 FOR PLACEMENT OF FINAL PAVEMENT MARKINGS, SYMBOLS, AND MARKERS UNLESS NOTED OTHERWISE.

SEE PMP-1 FOR PAVEMENT MARKING SCHEDULE





★ INDICATES PROPOSED SIGNALIZED INTERSECTION

☆ INDICATES MODIFIED SIGNALIZED INTERSECTION

SYMBOL	DESCRIPTION
↶	UA LEFT TURN ARROW
↷	UB RIGHT TURN ARROW
→	UC STRAIGHT ARROW
↷	UE COMB. STRAIGHT / RIGHT ARROW

PAVEMENT MARKING DETAIL

02-NOV-2012 11:32
 P:\IP\Projects\12-11-12\3324\Drawings\CADD\PM-3\3324-PM-3.dgn
 11-22-12 10:05
 11-22-12 10:05
 revision.dgn

SYMBOL	DESCRIPTION
	UA LEFT TURN ARROW
	UB RIGHT TURN ARROW
	UC STRAIGHT ARROW
	UE COMB. STRAIGHT / RIGHT ARROW
	UT MERGE ARROW

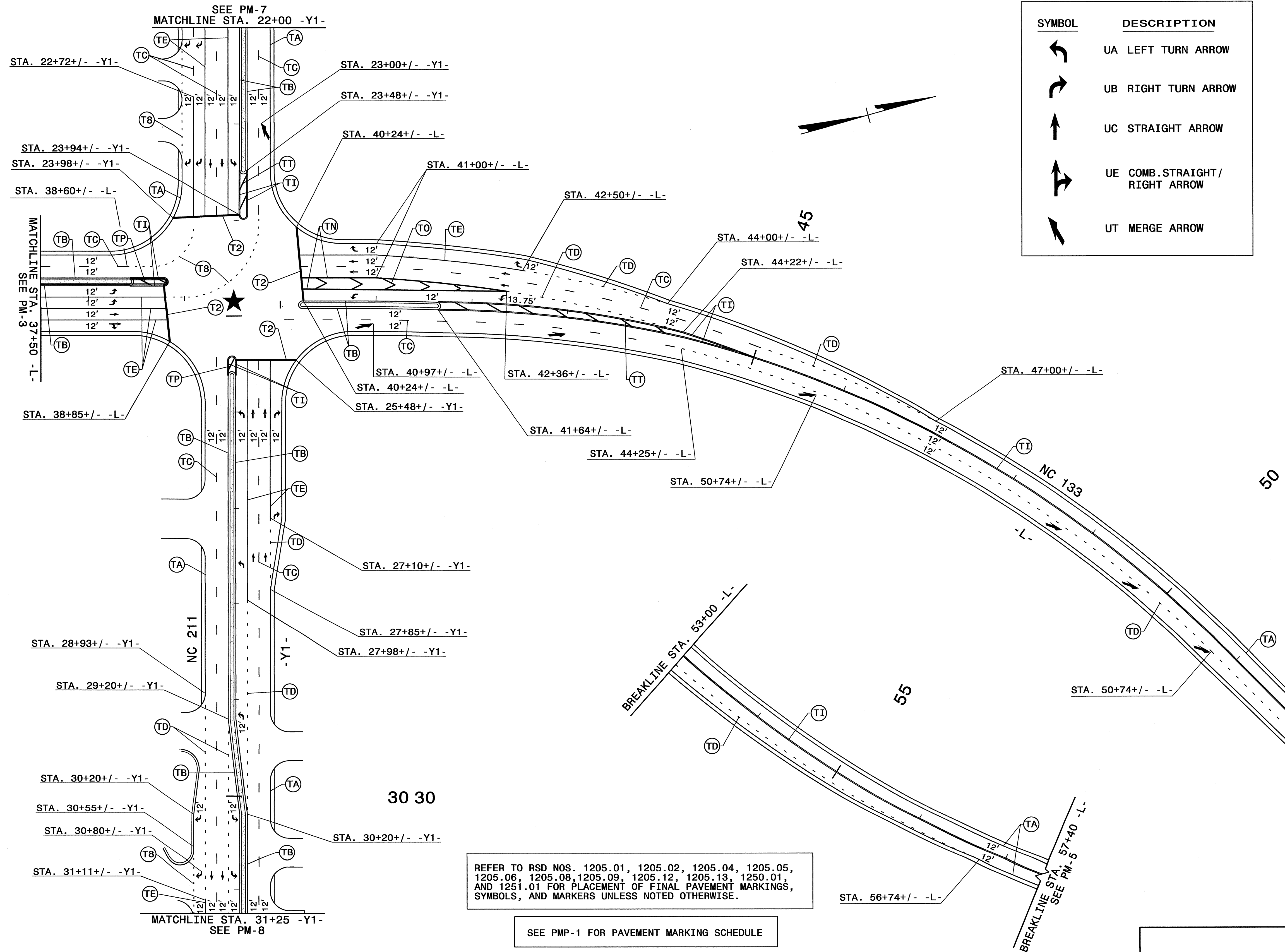

REFER TO RSD NOS. 1205.01, 1205.02, 1205.04, 1205.05, 1205.06, 1205.08, 1205.09, 1205.12, 1205.13, 1250.01, AND 1251.01 FOR PLACEMENT OF FINAL PAVEMENT MARKINGS, SYMBOLS, AND MARKERS UNLESS NOTED OTHERWISE.

SEE PMP-1 FOR PAVEMENT MARKING SCHEDULE

★ INDICATES PROPOSED SIGNALIZED INTERSECTION

PAVEMENT MARKING DETAIL

02-NOV-2012 11:33
 P:\TIP\Projects\3324\Tr of fic\Signing\CA00\PMP\3324_pm_pm04_revision.dgn
 er lewar.d AT 12:24:05

TIP NO.	SHEET NO.
R-3324	PMP-5
APPROVED: <i>[Signature]</i>	
DATE: 11-5-12	
SEAL	

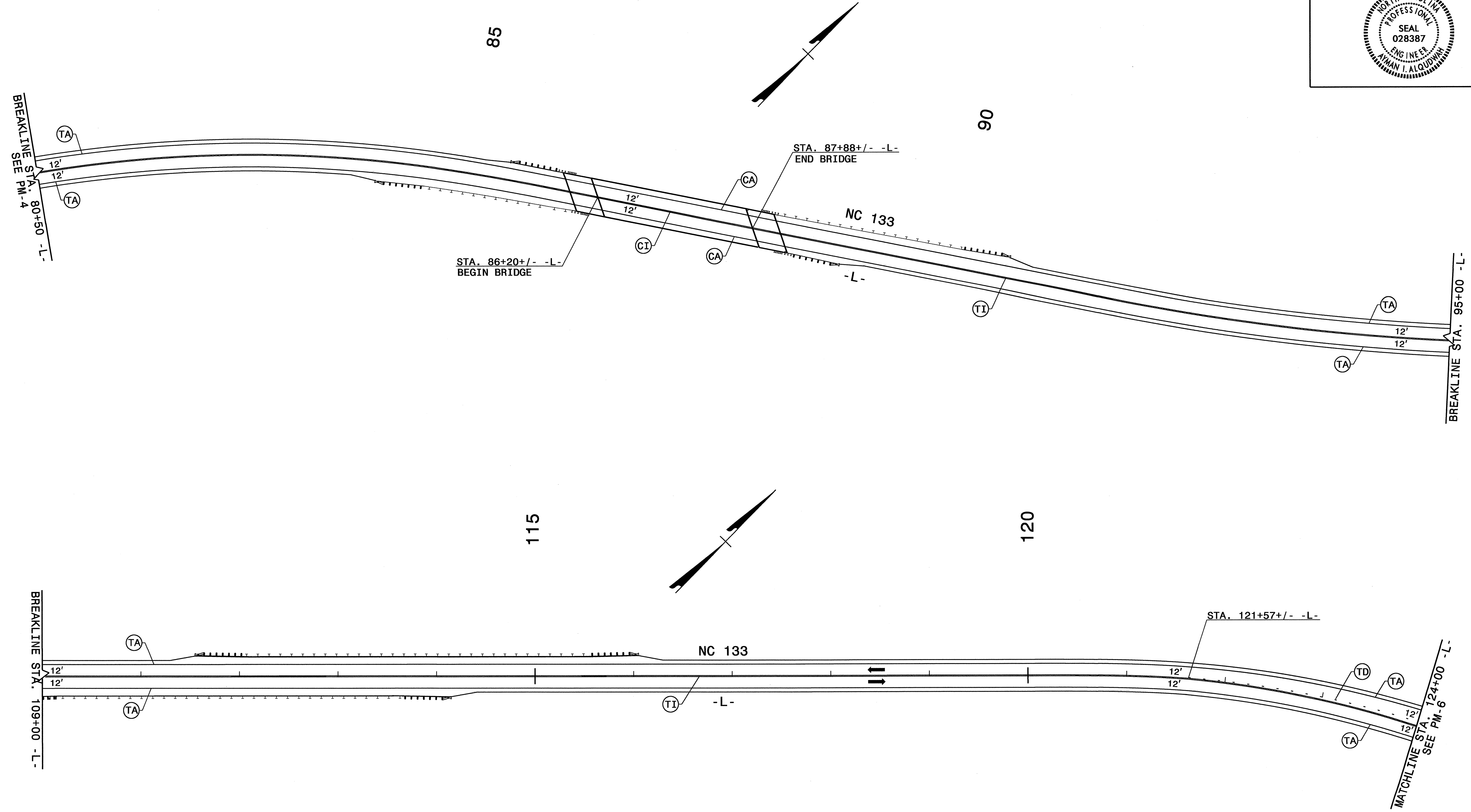

REFER TO RSD NOS. 1205.01, 1205.02, 1205.12, 1250.01, AND 1253.01 FOR PLACEMENT OF FINAL PAVEMENT MARKINGS, SYMBOLS, AND MARKERS UNLESS NOTED OTHERWISE.

SEE PMP-1A FOR PAVEMENT MARKING SCHEDULE





PAVEMENT MARKING DETAIL

02-NOV-2012 11:34
 P:\pmp-5\pmp-5.dwg
 eric.leward

REFER TO RSD NOS. 1205.01, 1205.02, 1205.04, 1205.05, 1205.06, 1205.08, 1205.09, 1205.12, 1205.13, 1250.01, AND 1251.01 FOR PLACEMENT OF FINAL PAVEMENT MARKINGS, SYMBOLS, AND MARKERS UNLESS NOTED OTHERWISE.

SEE PMP-1 FOR PAVEMENT MARKING SCHEDULE

★ INDICATES PROPOSED SIGNALIZED INTERSECTION

SYMBOL	DESCRIPTION
	UA LEFT TURN ARROW
	UB RIGHT TURN ARROW
	UC STRAIGHT ARROW
	UF COMB. LEFT/RIGHT ARROW
	UT MERGE ARROW

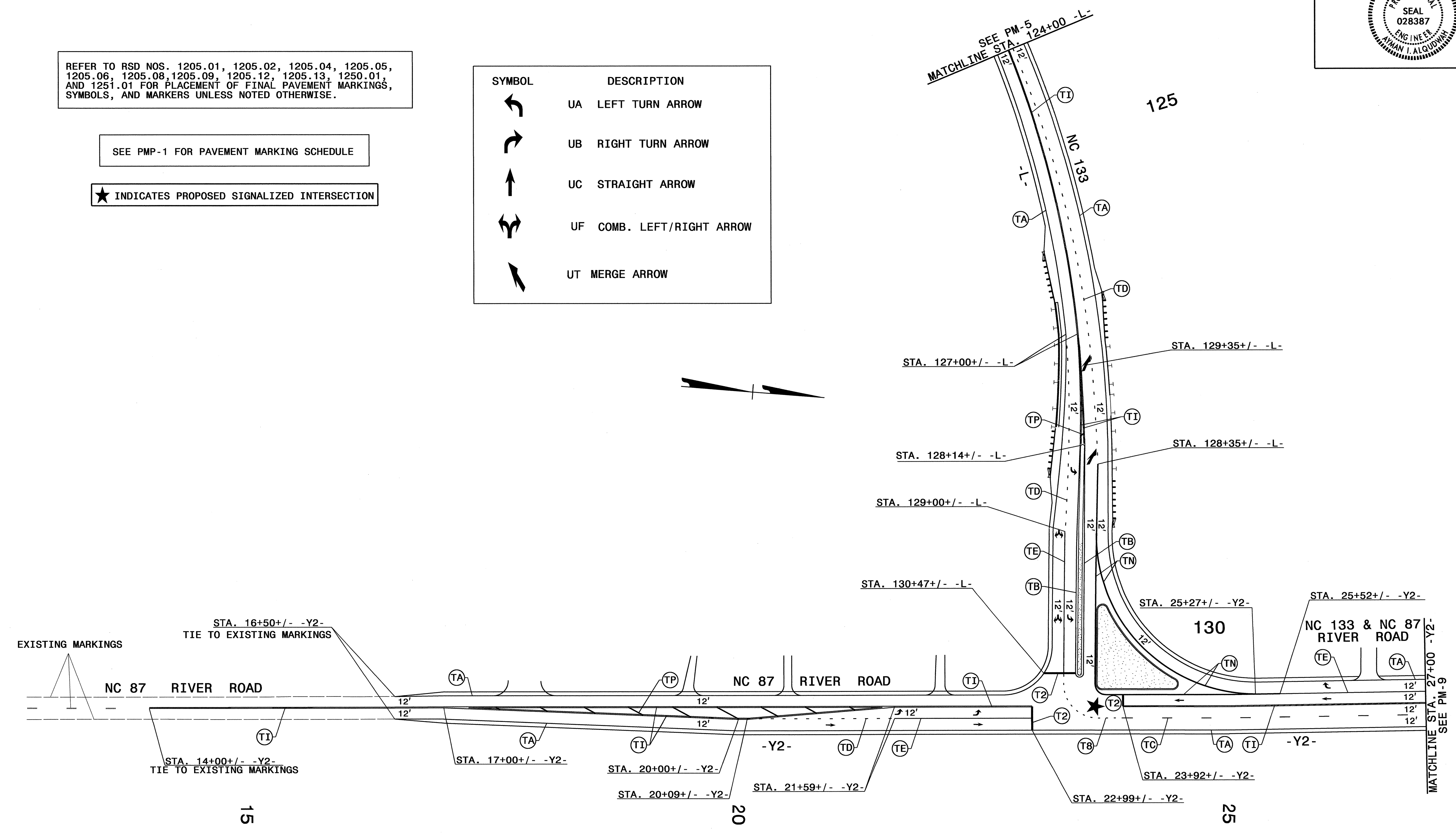

PAVEMENT MARKING DETAIL

02-NOV-2012 11:35 AM C:\Users\alqudus\Documents\Projects\3324\Drawings\CADD\PM\3324_pm.pn06_revision.dgn

TIP NO. R-3324	SHEET NO. PMP-7
APPROVED: <i>[Signature]</i>	
DATE: 11-5-12	
SEAL	

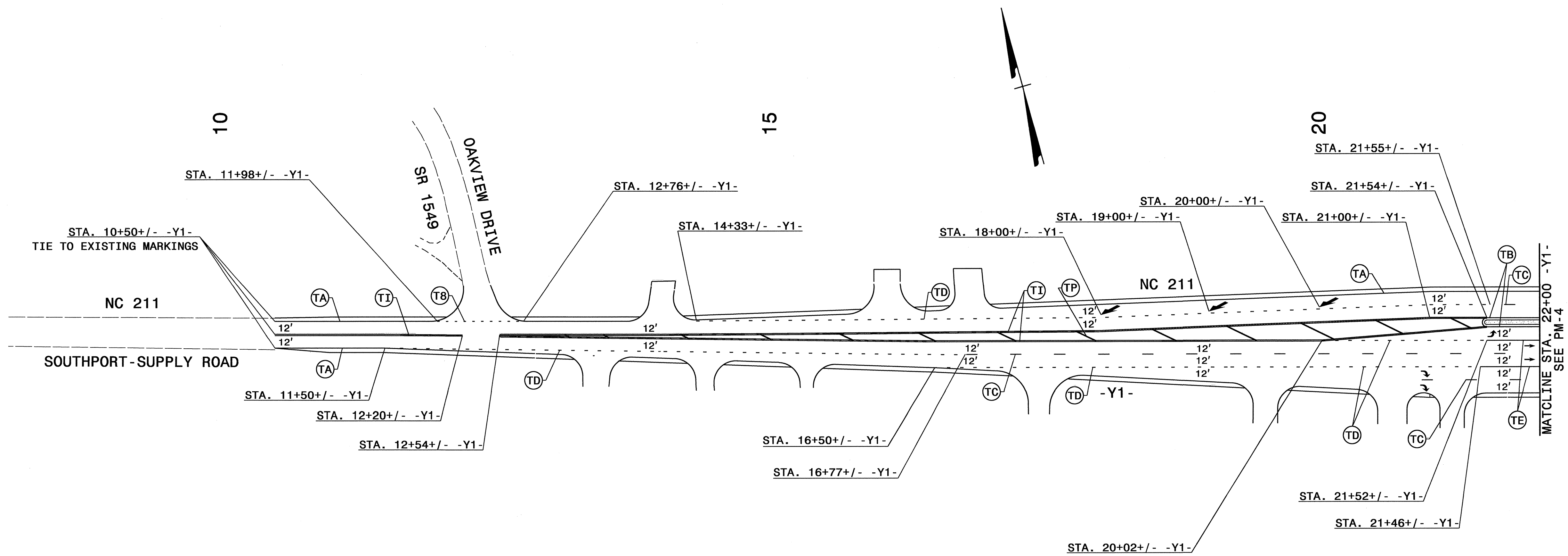

REFER TO RSD NOS. 1205.01, 1205.02, 1205.04, 1205.05, 1205.06, 1205.08, 1205.09, 1205.12, 1205.13, 1250.01, AND 1251.01 FOR PLACEMENT OF FINAL PAVEMENT MARKINGS, SYMBOLS, AND MARKERS UNLESS NOTED OTHERWISE.

SEE PMP-1 FOR PAVEMENT MARKING SCHEDULE

SYMBOL	DESCRIPTION
	UA LEFT TURN ARROW
	UB RIGHT TURN ARROW
	UC STRAIGHT ARROW
	UT MERGE ARROW

PAVEMENT MARKING DETAIL

02-NOV-2012 11:36
 F:\TIPProjects\R3324\Traffic Signing\CADD\PM-7\3324-pm-pm07_revision.dgn
 ericward AT 11-24-12

SYMBOL	DESCRIPTION
	UA LEFT TURN ARROW
	UB RIGHT TURN ARROW
	UC STRAIGHT ARROW
	UD COMB. STRAIGHT/RIGHT ARROW

REFER TO RSD NOS. 1205.01, 1205.02, 1205.04, 1205.05, 1205.06, 1205.08, 1205.09, 1205.12, 1205.13, 1250.01 AND 1251.01 FOR PLACEMENT OF FINAL PAVEMENT MARKINGS, SYMBOLS, AND MARKERS UNLESS NOTED OTHERWISE.

SEE PMP-1 FOR PAVEMENT MARKING SCHEDULE

★ INDICATES MODIFIED SIGNALIZED INTERSECTION

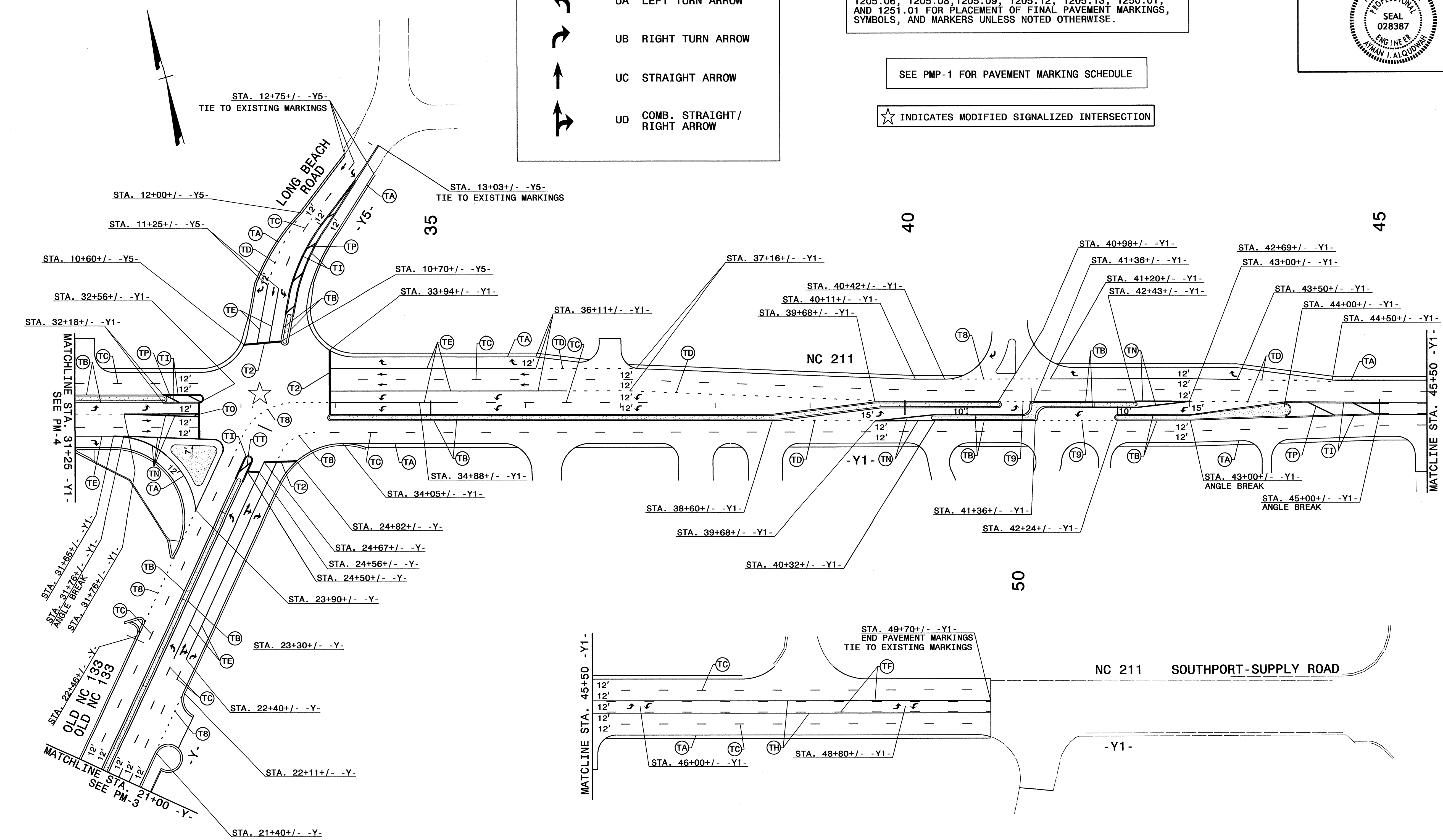

PAVEMENT MARKING DETAIL

02-NOV-2012 11:36 P:\IP\Projects\11-1227305\AT\11-1227305.dgn
 02-NOV-2012 11:36 P:\IP\Projects\11-1227305\AT\11-1227305.dgn
 02-NOV-2012 11:36 P:\IP\Projects\11-1227305\AT\11-1227305.dgn
 02-NOV-2012 11:36 P:\IP\Projects\11-1227305\AT\11-1227305.dgn

TIP NO. R-3324	SHEET NO. PMP-9
APPROVED: <i>[Signature]</i>	
DATE: 11-5-12	
SEAL	

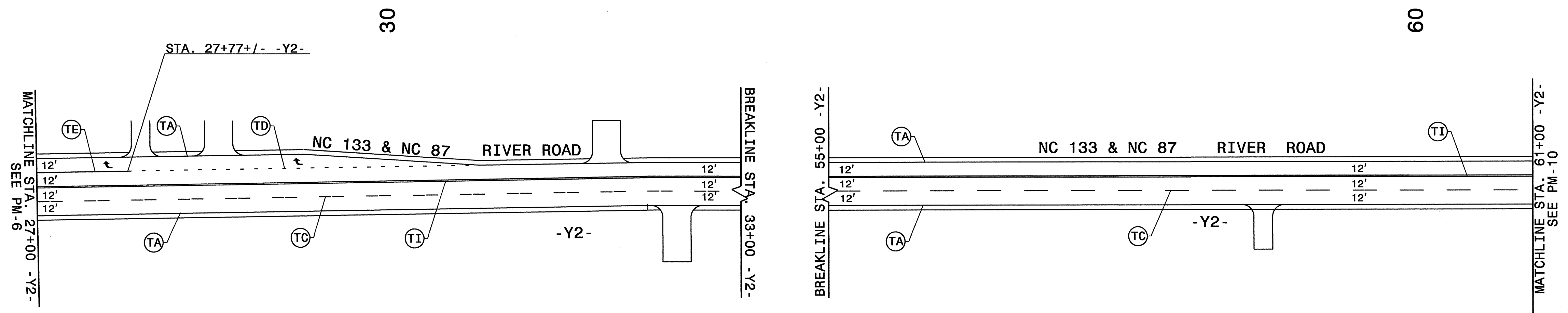

REFER TO RSD NOS. 1205.01, 1205.02, 1205.04, 1205.05, 1205.06, 1205.08, 1205.09, 1205.12, 1205.13, 1250.01, AND 1251.01 FOR PLACEMENT OF FINAL PAVEMENT MARKINGS, SYMBOLS, AND MARKERS UNLESS NOTED OTHERWISE.

SEE PMP-1 FOR PAVEMENT MARKING SCHEDULE

SEE PMP-1A FOR PAVEMENT MARKING SCHEDULE

SYMBOL	DESCRIPTION
↪	UB RIGHT TURN ARROW

PAVEMENT MARKING DETAIL

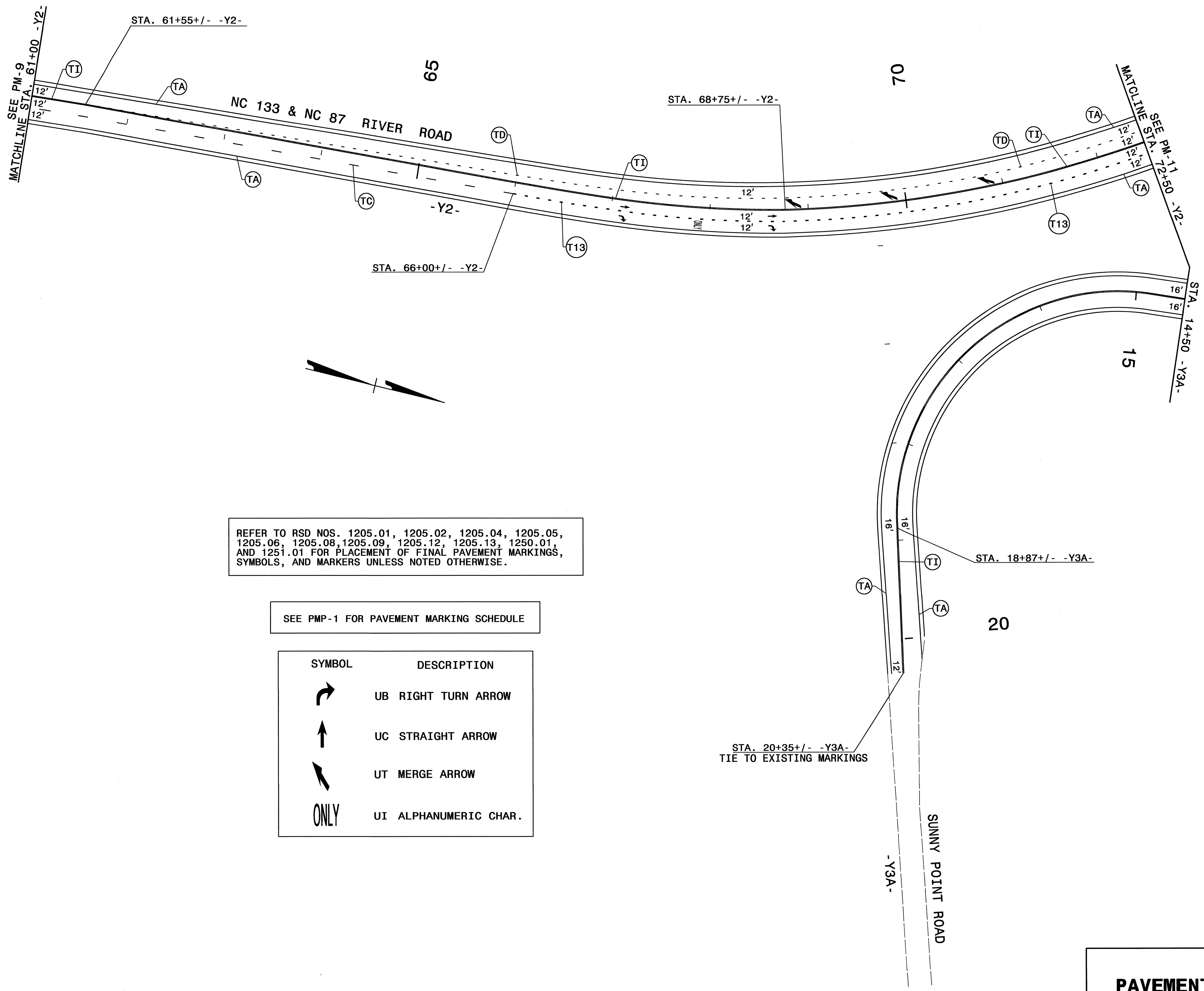

02-NOV-2012 11:37 AM A:\work\cjob\1611\1611.dwg AT 11:27:50

TIP NO. R-3324	SHEET NO. PMP-10
APPROVED: <i>[Signature]</i>	
DATE: 11-5-12	
SEAL	
	



REFER TO RSD NOS. 1205.01, 1205.02, 1205.04, 1205.05, 1205.06, 1205.08, 1205.09, 1205.12, 1205.13, 1250.01, AND 1251.01 FOR PLACEMENT OF FINAL PAVEMENT MARKINGS, SYMBOLS, AND MARKERS UNLESS NOTED OTHERWISE.

SEE PMP-1 FOR PAVEMENT MARKING SCHEDULE

SYMBOL	DESCRIPTION
	UB RIGHT TURN ARROW
	UC STRAIGHT ARROW
	UT MERGE ARROW
ONLY	UI ALPHANUMERIC CHAR.

PAVEMENT MARKING DETAIL

06-DEC-2012 12:34
 F:\IP\Projects\11-11-12\11-11-12\11-11-12\11-11-12\CADD\PM-10\PM-10.dgn
 AT 11-11-12

TIP NO.	SHEET NO.
R-3324	PMP-11
APPROVED: <i>[Signature]</i>	
DATE: 11-5-12	
SEAL	

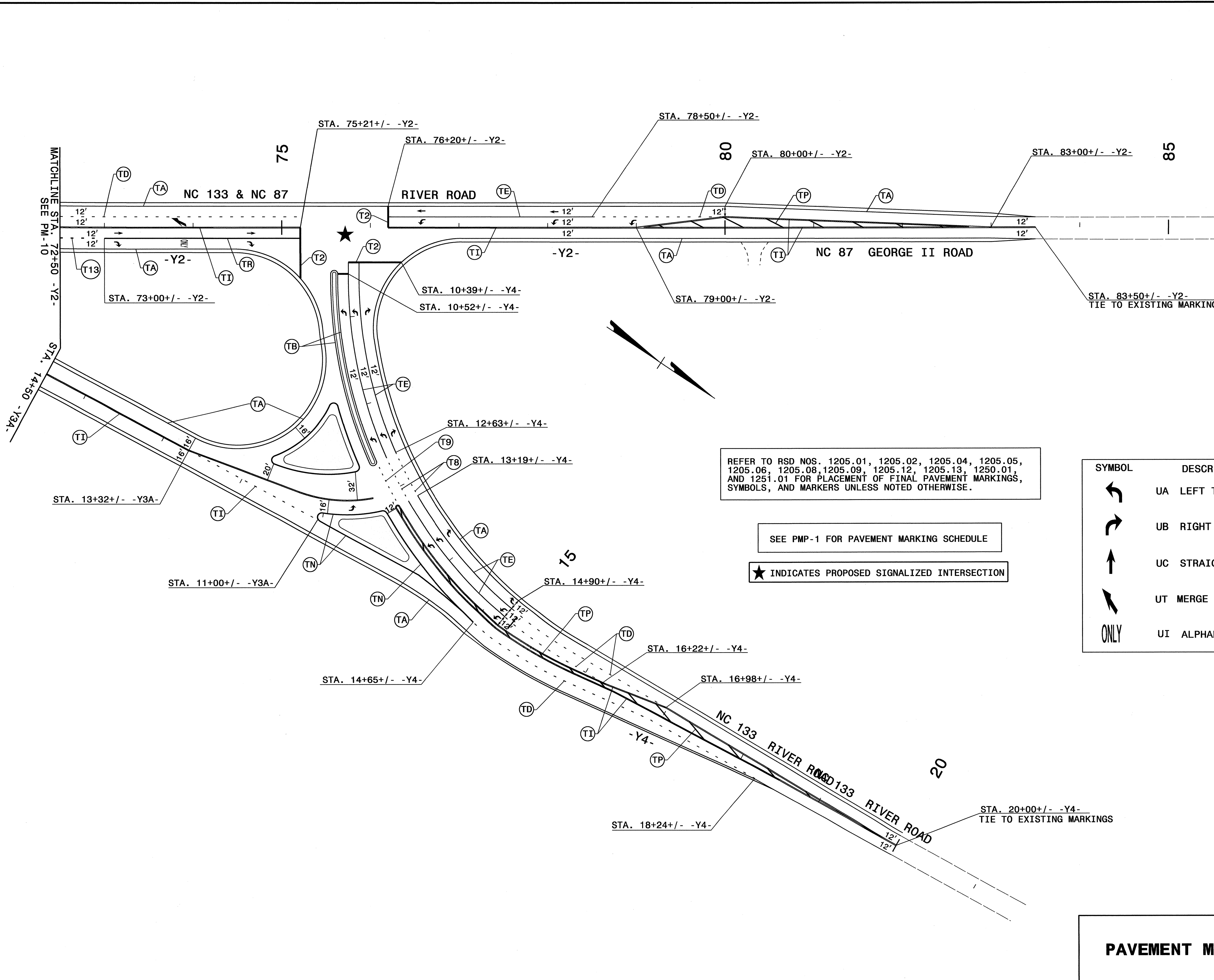

REFER TO RSD NOS. 1205.01, 1205.02, 1205.04, 1205.05, 1205.06, 1205.08, 1205.09, 1205.12, 1205.13, 1250.01, AND 1251.01 FOR PLACEMENT OF FINAL PAVEMENT MARKINGS, SYMBOLS, AND MARKERS UNLESS NOTED OTHERWISE.

SEE PMP-1 FOR PAVEMENT MARKING SCHEDULE

★ INDICATES PROPOSED SIGNALIZED INTERSECTION

SYMBOL	DESCRIPTION
	UA LEFT TURN ARROW
	UB RIGHT TURN ARROW
	UC STRAIGHT ARROW
	UT MERGE ARROW
	UI ALPHANUMERIC

PAVEMENT MARKING DETAIL

02-NOV-2012 11:38
 P:\TIP\Project\3-R3324\Traffic\Signing\CADD\PM\vr3324_pm_pml\revision.dgn
 ericward AT 11/24/2012