

TIP PROJECT: B-4864

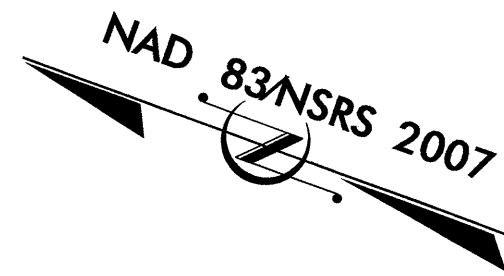

STATE OF NORTH CAROLINA
 DIVISION OF HIGHWAYS

 PLAN FOR PROPOSED
 HIGHWAY EROSION CONTROL

ROCKINGHAM COUNTY

LOCATION: BRIDGE NO. 13 OVER TROUBLESOME CREEK ON SR 2344

TYPE OF WORK: GRADING, PAVING, DRAINAGE AND CULVERT

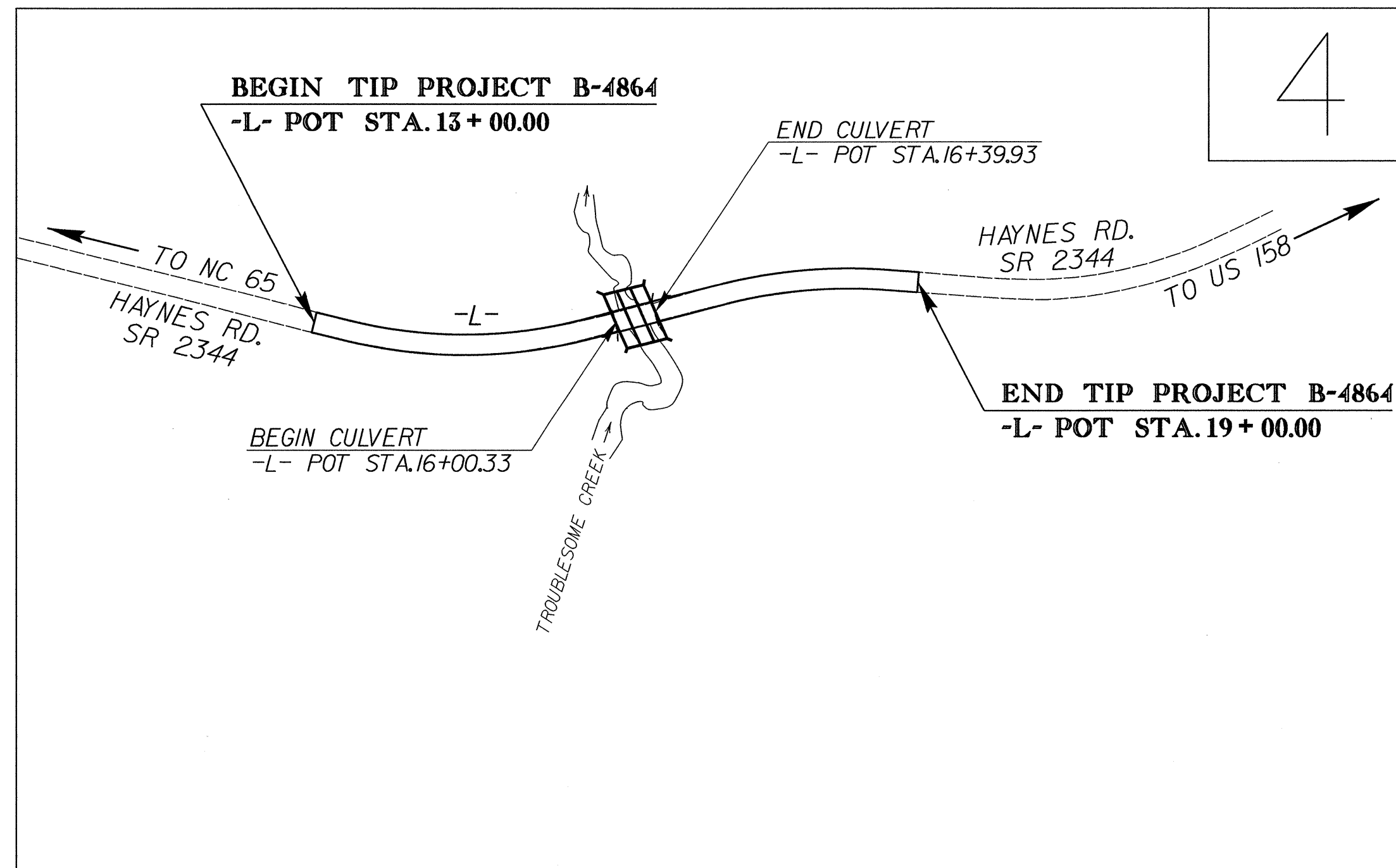

STATE	STATE PROJECT REFERENCE NO.	SHEET NO.	TOTAL SHEETS
N.C.	B-4864	EC-1	
STATE PROJ. NO.	F.A. PROJ. NO.	DESCRIPTION	

EROSION AND SEDIMENT CONTROL MEASURES

Std. #	Description	Symbol
1630.03	Temporary Silt Ditch.....	
1630.05	Temporary Diversion.....	
1605.01	Temporary Silt Fence.....	
1606.01	Special Sediment Control Fence.....	
1622.01	Temporary Berms and Slope Drains.....	
1630.02	Silt Basin Type B.....	
1633.01	Temporary Rock Silt Check Type-A.....	
	Temporary Rock Silt Check Type-A with Matting and Polyacrylamide (PAM).....	
1633.02	Temporary Rock Silt Check Type-B.....	
	Wattle / Coir Fiber Wattle.....	
	Wattle / Coir Fiber Wattle with Polyacrylamide (PAM).....	
1634.01	Temporary Rock Sediment Dam Type-A.....	
1634.02	Temporary Rock Sediment Dam Type-B.....	
1635.01	Rock Pipe Inlet Sediment Trap Type-A.....	
1635.02	Rock Pipe Inlet Sediment Trap Type-B.....	
1630.04	Stilling Basin.....	
1630.06	Special Stilling Basin.....	
	Rock Inlet Sediment Trap:	
1632.01	Type A.....	
1632.02	Type B.....	
1632.03	Type C.....	
	Skimmer Basin.....	
	Tiered Skimmer Basin.....	
	Infiltration Basin.....	

THIS PROJECT CONTAINS EROSION CONTROL PLANS FOR CLEARING AND GRUBBING PHASE OF CONSTRUCTION.

THIS PROJECT HAS BEEN DESIGNED TO SENSITIVE WATERSHED STANDARDS.

ENVIRONMENTALLY SENSITIVE AREA(S) EXIST ON THIS PROJECT
 Refer To E. C. Special Provisions for Special Considerations.

GRAPHIC SCALE

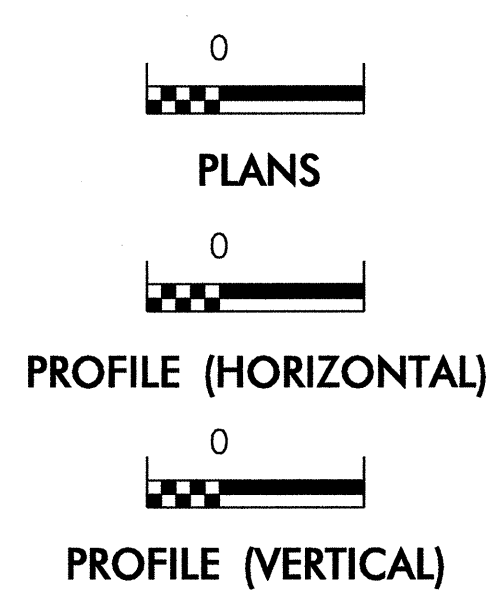

ROADSIDE ENVIRONMENTAL UNIT
 DIVISION OF HIGHWAYS
 STATE OF NORTH CAROLINA

THESE EROSION AND SEDIMENT CONTROL PLANS COMPLY WITH THE REGULATIONS SET FORTH BY THE NCG-010000 GENERAL CONSTRUCTION PERMIT EFFECTIVE AUGUST 3, 2011 ISSUED BY THE NORTH CAROLINA DEPARTMENT OF ENVIRONMENT AND NATURAL RESOURCES DIVISION OF WATER QUALITY.

Prepared in the Office of:
ROADSIDE ENVIRONMENTAL UNIT
 1 South Wilmington St.
 Raleigh, NC 27611
2012 STANDARD SPECIFICATIONS

Roadway Standard Drawings

The following roadway english standards as appear in "Roadway Standard Drawings"- Roadway Design Unit - N. C. Department of Transportation - Raleigh, N. C., dated January 2012 and the latest revision thereto are applicable to this project and by reference hereby are considered a part of these plans.

1604.01 Railroad Erosion Control Detail	1632.01 Rock Inlet Sediment Trap Type A
1605.01 Temporary Silt Fence	1632.02 Rock Inlet Sediment Trap Type B
1606.01 Special Sediment Control Fence	1632.03 Rock Inlet Sediment Trap Type C
1607.01 Gravel Construction Entrance	1633.01 Temporary Rock Silt Check Type A
1622.01 Temporary Berms and Slope Drains	1633.02 Temporary Rock Silt Check Type B
1630.01 Riser Basin	1634.01 Temporary Rock Sediment Dam Type A
1630.02 Silt Basin Type B	1634.02 Temporary Rock Sediment Dam Type B
1630.03 Temporary Silt Ditch	1635.01 Rock Pipe Inlet Sediment Trap Type A
1630.04 Stilling Basin	1635.02 Rock Pipe Inlet Sediment Trap Type B
1630.05 Temporary Diversion	1640.01 Coir Fiber Baffle
1630.06 Special Stilling Basin	1645.01 Temporary Stream Crossing
1631.01 Matting Installation	

01-NOV-2012 12:07
 R:\ENVIRONMENTAL\B4864\EC-1.dgn
 P:\NS

PROJECT REFERENCE NO. B-4864	SHEET NO. EC-2
RW SHEET NO.	
ROADWAY DESIGN ENGINEER	HYDRAULICS ENGINEER

SKIMMER BASIN WITH BAFFLES DETAIL

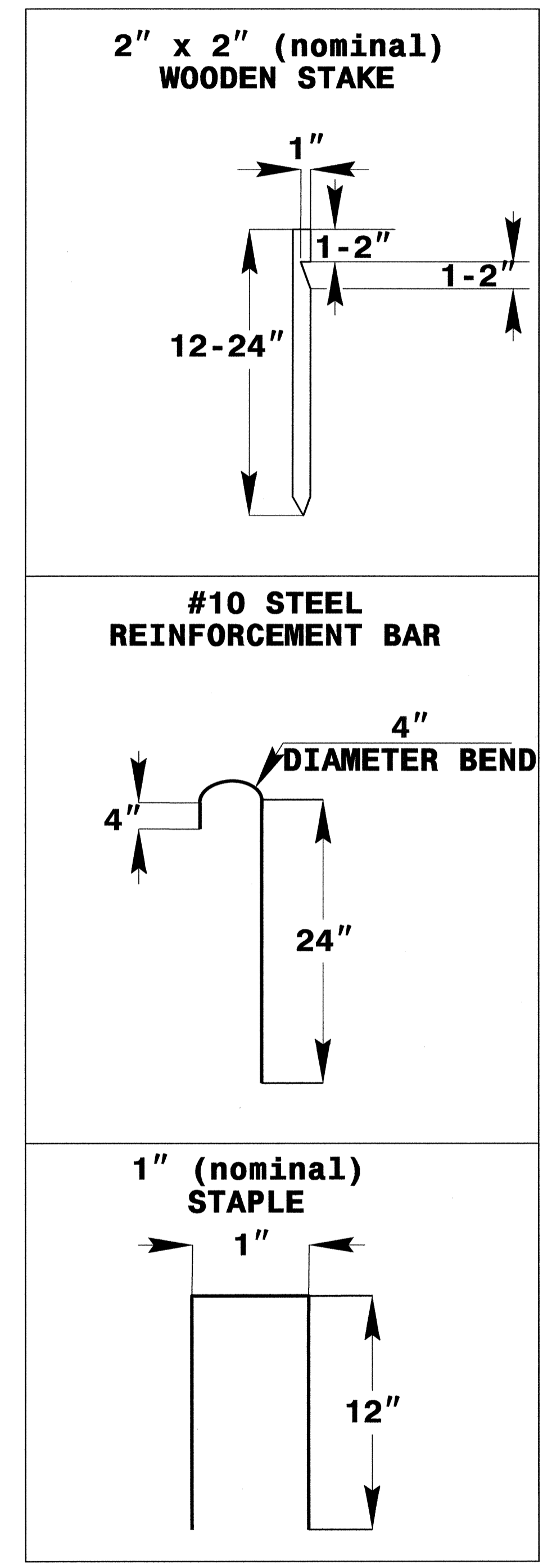
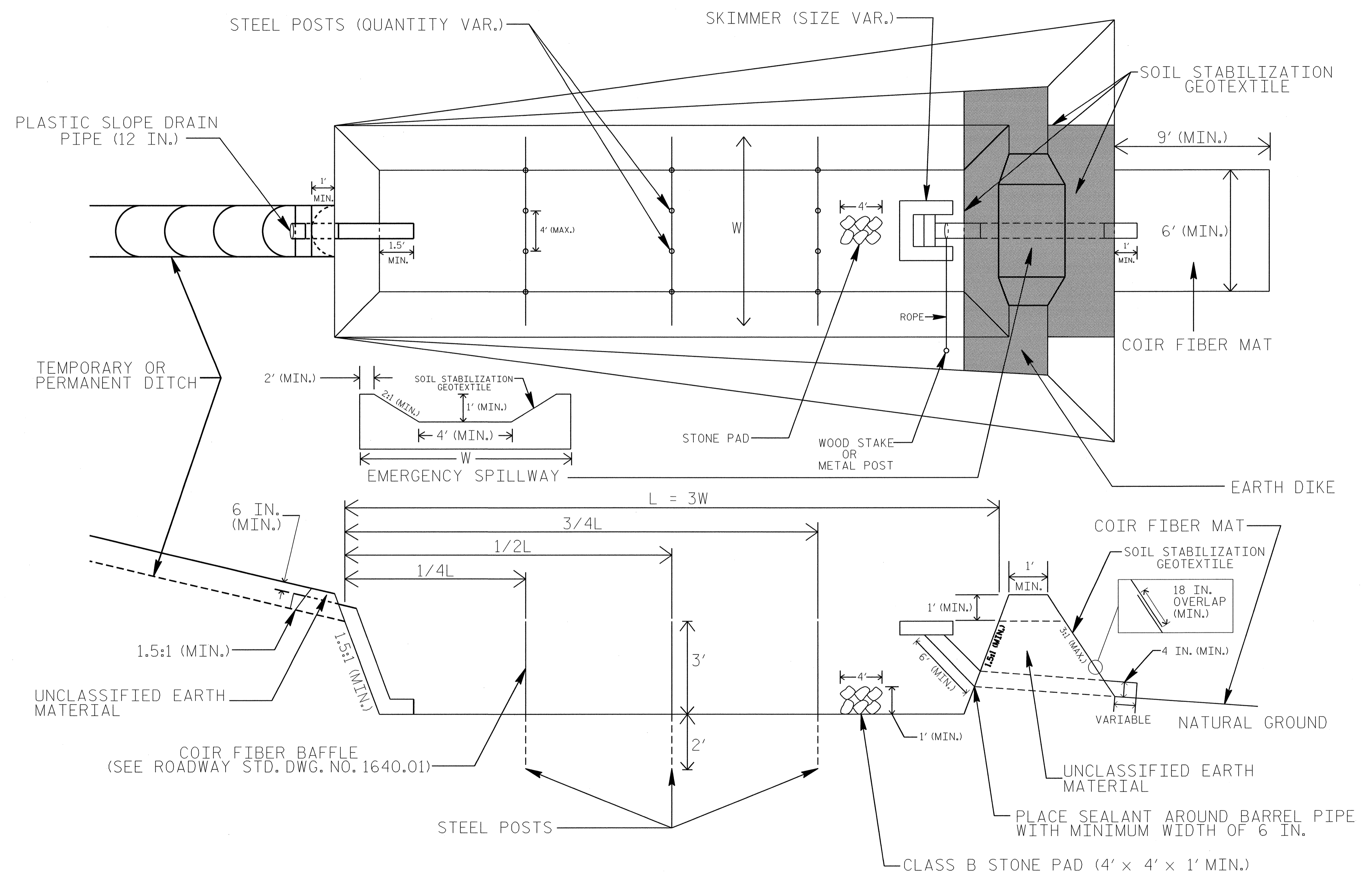

COIR FIBER MAT ANCHOR OPTIONS

NOTES

1. SEED AND PLACE MATTING FOR EROSION CONTROL ON INTERIOR AND EXTERIOR SIDESLOPES.
2. LIMIT EARTH DIKE HEIGHT TO 5 FT.
3. FOR BASIN DEPTH OF 3 FT., THE MINIMUM BASIN WIDTH SHALL BE 9 FT.
4. DETERMINE EMERGENCY SPILLWAY WEIR LENGTH (FT.) USING $Q/0.8$, WHERE Q IS FLOW RATE (CFS) INTO BASIN.
5. PLASTIC SLOPE DRAIN PIPE AT INLET OF BASIN MAY BE REPLACED BY FILTRATION GEOTEXTILE OR TARP AS DIRECTED.
6. SOIL STABILIZATION GEOTEXTILE FOR EMERGENCY SPILLWAY SHALL BE ONE CONTINUOUS PIECE OF MATERIAL OR OVERLAPPED 18 IN. (MIN.).

NOT TO SCALE

PROJECT REFERENCE NO. B-4864	SHEET NO. EC-2A
RW SHEET NO.	
ROADWAY DESIGN ENGINEER	HYDRAULICS ENGINEER

WATTLE WITH POLYACRYLAMIDE (PAM) DETAIL

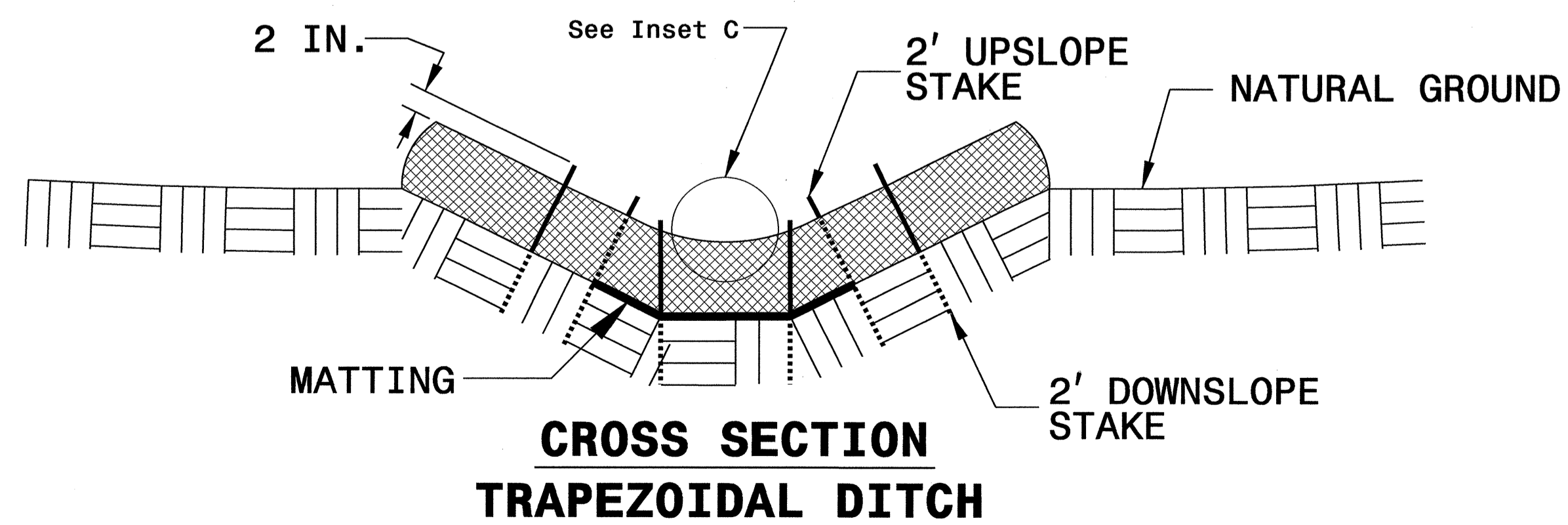
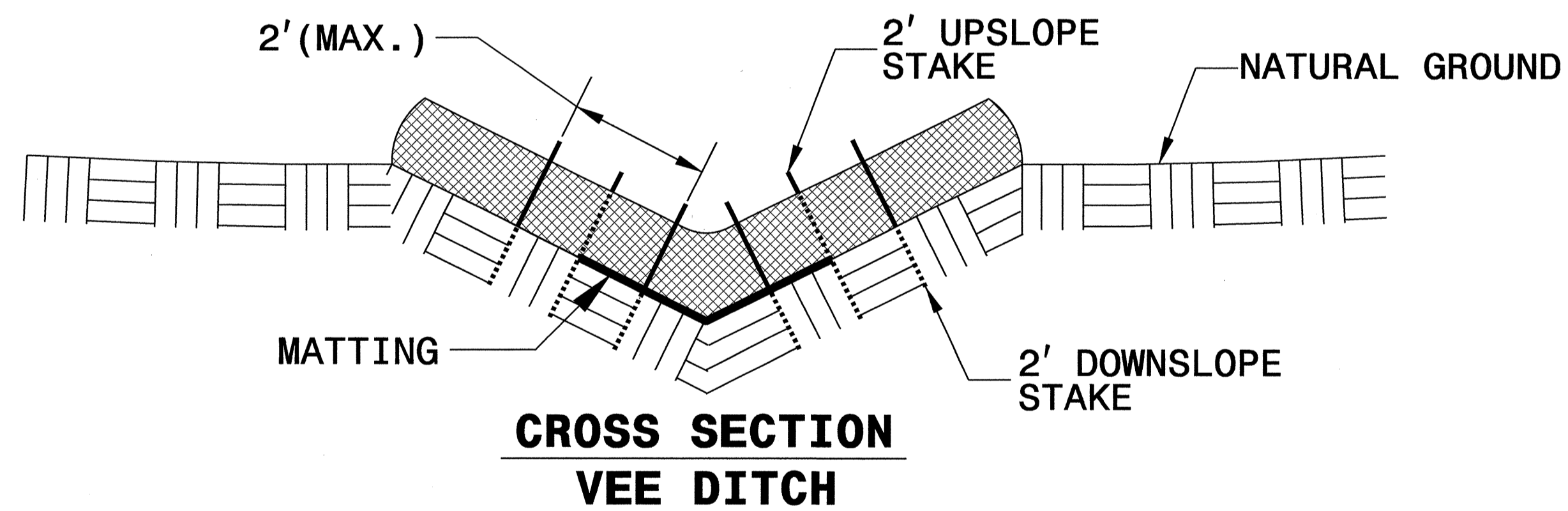
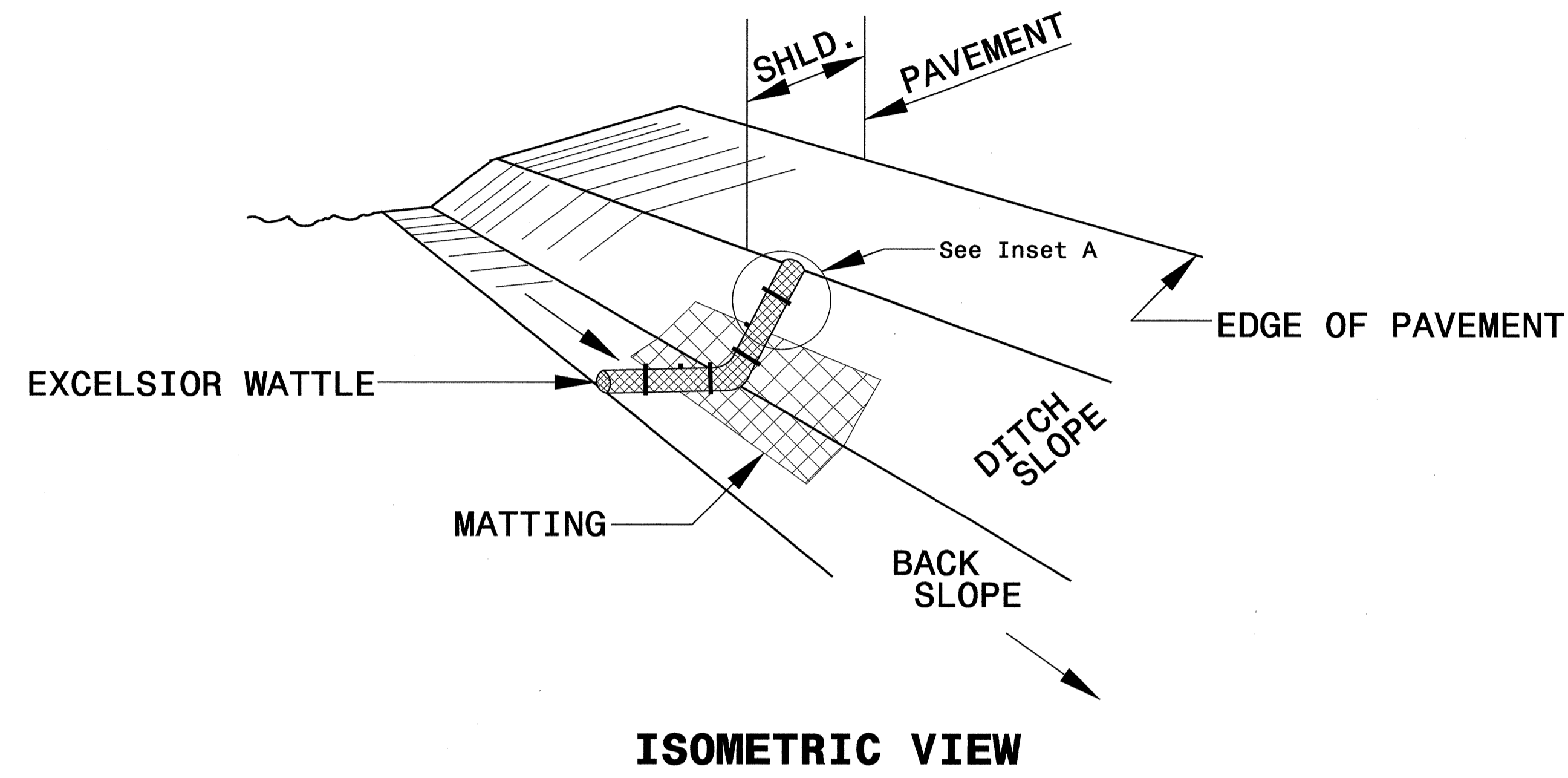

NOTES:

USE MINIMUM 12 IN. DIAMETER EXCELSIOR WATTLE.

USE 2 FT. WOODEN STAKES WITH A 2 IN. BY 2 IN. NOMINAL CROSS SECTION.

ONLY INSTALL WATTLE(S) TO A HEIGHT IN DITCH SO FLOW WILL NOT WASH AROUND WATTLE AND SCOUR DITCH SLOPES AND AS DIRECTED.

INSTALL A MINIMUM OF 2 UPSLOPE STAKES AND 4 DOWNSLOPE STAKES AT AN ANGLE TO WEDGE WATTLE TO BOTTOM OF DITCH.

PROVIDE STAPLES MADE OF 0.125 IN. DIAMETER STEEL WIRE FORMED INTO A U SHAPE NOT LESS THAN 12" IN LENGTH.

INSTALL STAPLES APPROXIMATELY EVERY 1 LINEAR FOOT ON BOTH SIDES OF WATTLE AND AT EACH END TO SECURE IT TO THE SOIL.

INSTALL MATTING IN ACCORDANCE WITH SECTION 1631 OF THE STANDARD SPECIFICATIONS.

PRIOR TO POLYACRYLAMIDE (PAM) APPLICATION, OBTAIN A SOIL SAMPLE FROM PROJECT LOCATION, AND FROM OFFSITE MATERIAL, AND ANALYZE FOR APPROPRIATE PAM FLOCCULANT TO BE APPLIED TO EACH WATTLE.

INITIALLY APPLY 2 OUNCES OF ANIONIC OR NEUTRALLY CHARGED PAM OVER WATTLE WHERE WATER WILL FLOW AND 1 OUNCE OF PAM ON MATTING ON EACH SIDE OF WATTLE. REAPPLY PAM AFTER EVERY RAINFALL EVENT THAT IS EQUAL TO OR EXCEEDS 0.50 IN.

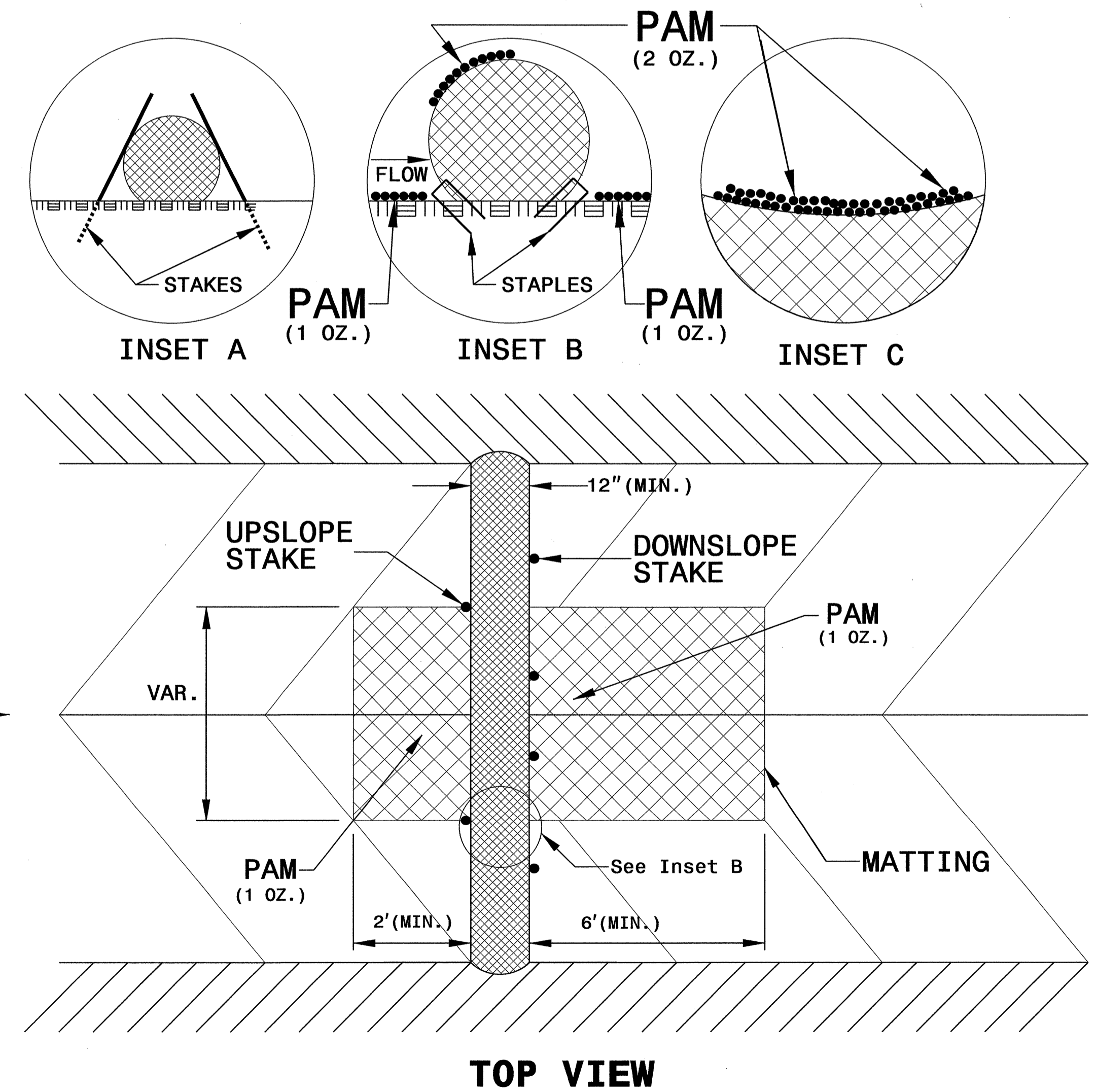

PROJECT REFERENCE NO. B-4864	SHEET NO. EC-2B
RW SHEET NO.	
ROADWAY DESIGN ENGINEER	HYDRAULICS ENGINEER

TEMPORARY ROCK SILT CHECK TYPE 'A' WITH EXCELSIOR MATTING AND POLYACRYLAMIDE (PAM)

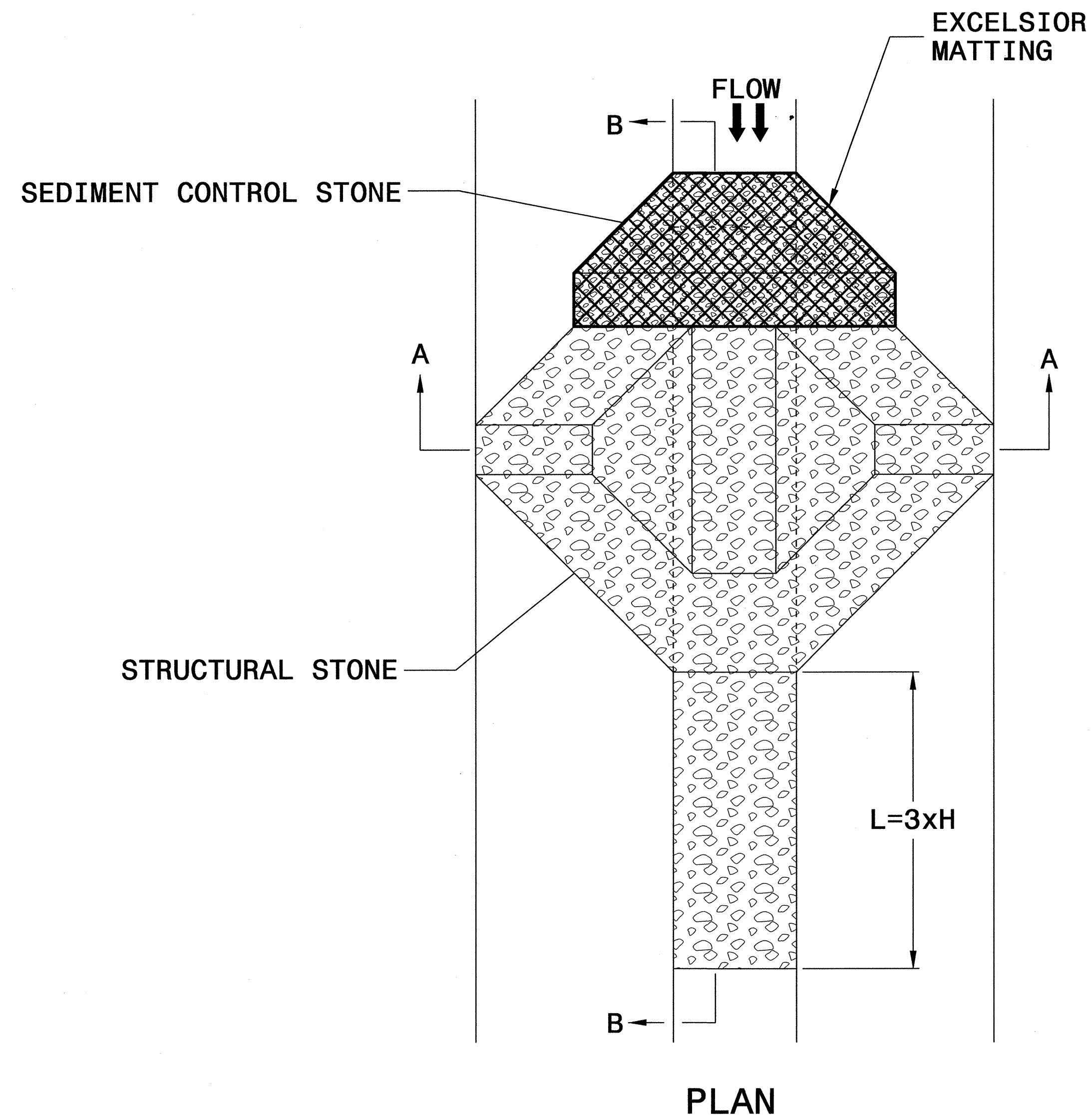

NOTES

USE EXCELSIOR FOR MATTING MATERIAL AND ANCHOR MATTING SECTION AT TOP AND BOTTOM WITH CLASS B STONE.

PRIOR TO POLYACRYLAMIDE (PAM) APPLICATION, OBTAIN A SOIL SAMPLE FROM PROJECT LOCATION, AND FROM OFFSITE MATERIAL, AND ANALYZE FOR APPROPRIATE PAM FLOCCULANT TO BE APPLIED TO EACH ROCK SILT CHECK.

INITIALLY APPLY 3.5 OUNCES OF POLYACRYLAMIDE (PAM) TO TOP OF MATTING SECTION AND AFTER EVERY RAINFALL EVENT THAT EQUALS OR EXCEEDS 0.50 INCHES.

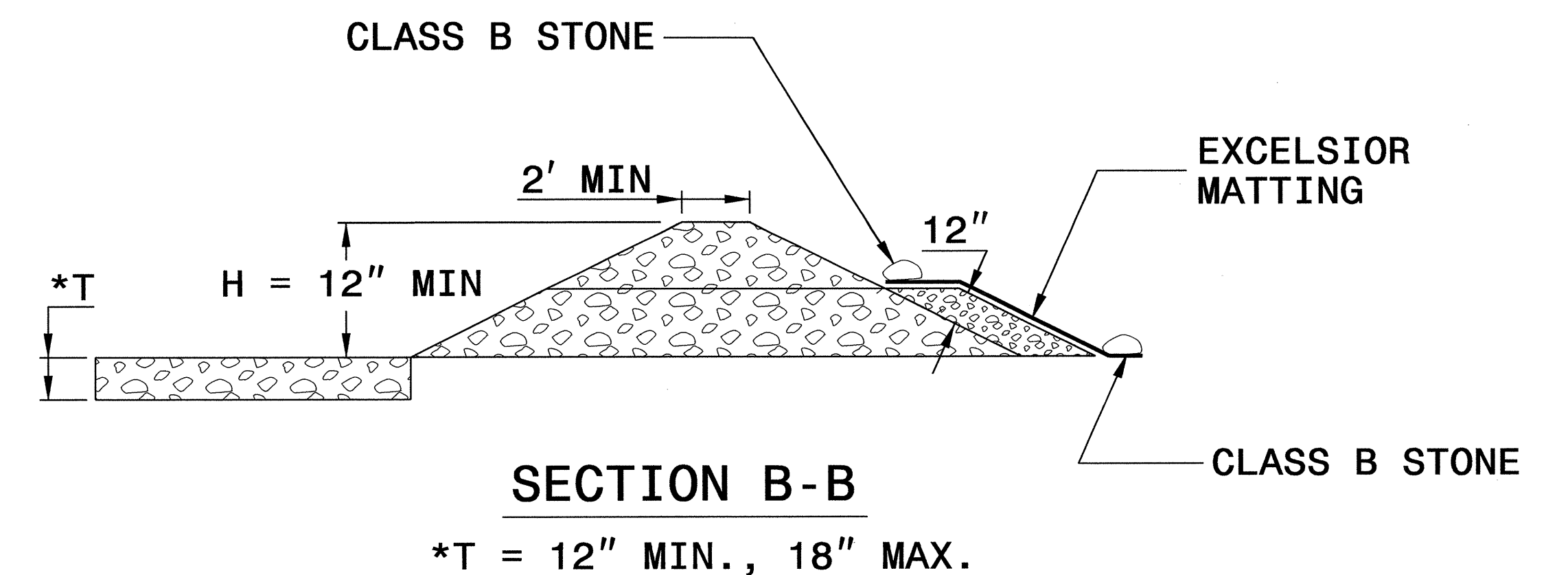
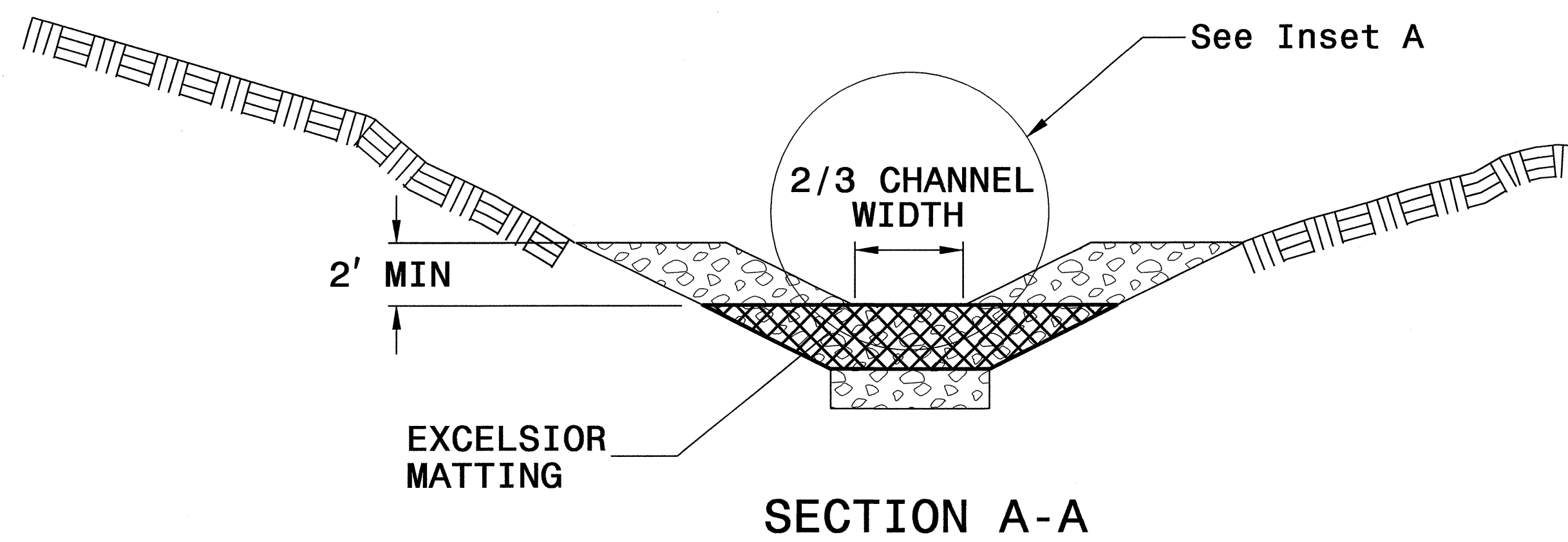
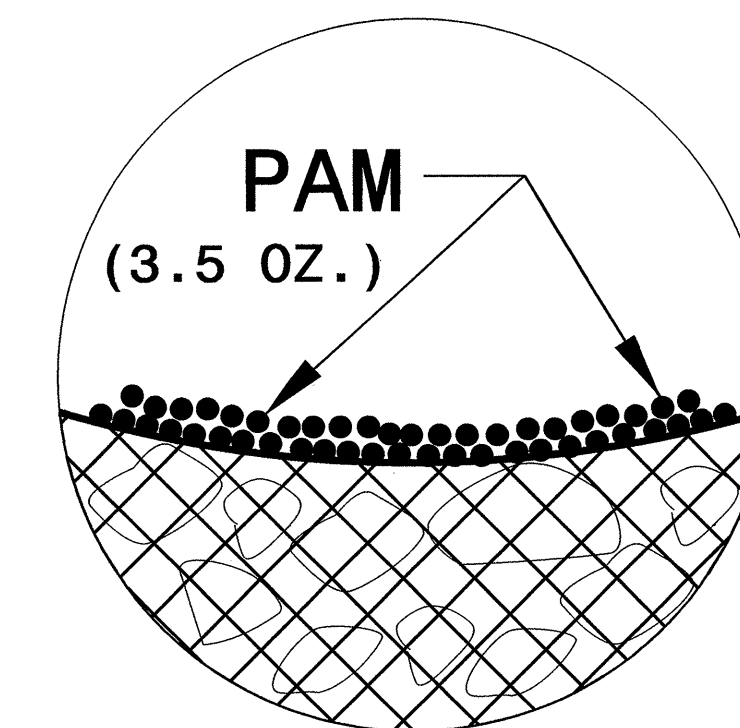

NOT TO SCALE

DIVISION OF HIGHWAYS
STATE OF NORTH CAROLINA

PROJECT REFERENCE NO. <i>B-4864</i>	SHEET NO. <i>EC-3</i>
ROADWAY DESIGN ENGINEER	HYDRAULICS ENGINEER

SOIL STABILIZATION TIMEFRAMES

<i>SITE DESCRIPTION</i>	<i>STABILIZATION TIME</i>	<i>TIMEFRAME EXCEPTIONS</i>
PERIMETER DIKES, SWALES, DITCHES AND SLOPES	7 DAYS	NONE
HIGH QUALITY WATER (HQW) ZONES	7 DAYS	NONE
SLOPES STEEPER THAN 3:1	7 DAYS	IF SLOPES ARE 10' OR LESS IN LENGTH AND ARE NOT STEEPER THAN 2:1, 14 DAYS ARE ALLOWED.
SLOPES 3:1 OR FLATTER	14 DAYS	7 DAYS FOR SLOPES GREATER THAN 50' IN LENGTH.
ALL OTHER AREAS WITH SLOPES FLATTER THAN 4:1	14 DAYS	NONE, EXCEPT FOR PERIMETERS AND HQW ZONES.

8/17/99

NOTE: PLACE TEMPORARY ROCK SEDIMENT DAMS TYPE - B AND TEMPORARY ROCK SILT CHECKS TYPE - A AT DRAINAGE OUTLETS.

CLEARING AND GRUBBING EROSION CONTROL FOR CONSTRUCTION SHEET 4

NAD 83/NRS 2007

BOBBY A. NEWSOM

36 x 18 x 2
1.5 inch Skimmer
with 0.375 inch
Orifice Diameter
10 ft. weir
ID 4.1

26 x 13 x 2
1.5 inch Skimmer
with 0.250 inch
Orifice Diameter
5 ft. weir
ID 4.3

ENVIRONMENTALLY SENSITIVE AREA
SEE PROJECT SPECIAL PROVISIONS

PROJECT REFERENCE NO. B-4864	SHEET NO. EC-04/CONST.04
RW SHEET NO.	HYDRAULICS ENGINEER
ROADWAY DESIGN ENGINEER	

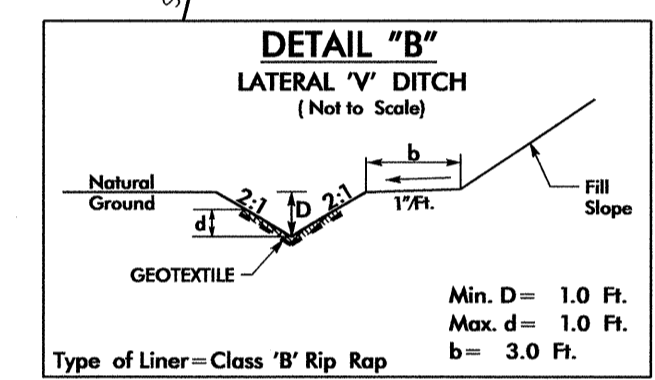
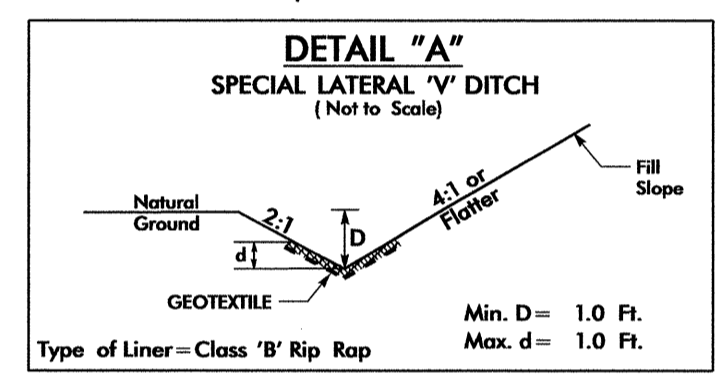
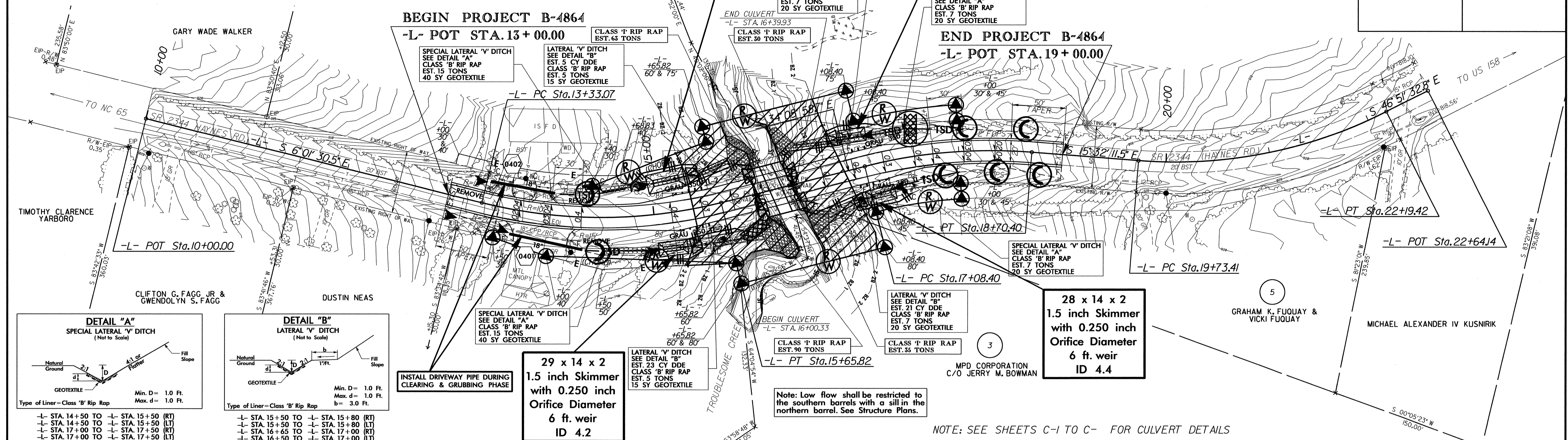

- L- STA. 14+50 TO -L- STA. 15+50 (RT)
- L- STA. 14+50 TO -L- STA. 15+50 (LT)
- L- STA. 17+00 TO -L- STA. 17+50 (RT)
- L- STA. 17+00 TO -L- STA. 17+50 (LT)

- L- STA. 15+50 TO -L- STA. 15+80 (RT)
- L- STA. 15+50 TO -L- STA. 15+80 (LT)
- L- STA. 16+65 TO -L- STA. 17+00 (RT)
- L- STA. 16+50 TO -L- STA. 17+00 (LT)

29 x 14 x 2
1.5 inch Skimmer
with 0.250 inch
Orifice Diameter
6 ft. weir
ID 4.2

28 x 14 x 2
1.5 inch Skimmer
with 0.250 inch
Orifice Diameter
6 ft. weir
ID 4.4

NOTE: SEE SHEETS C-1 TO C- FOR CULVERT DETAILS

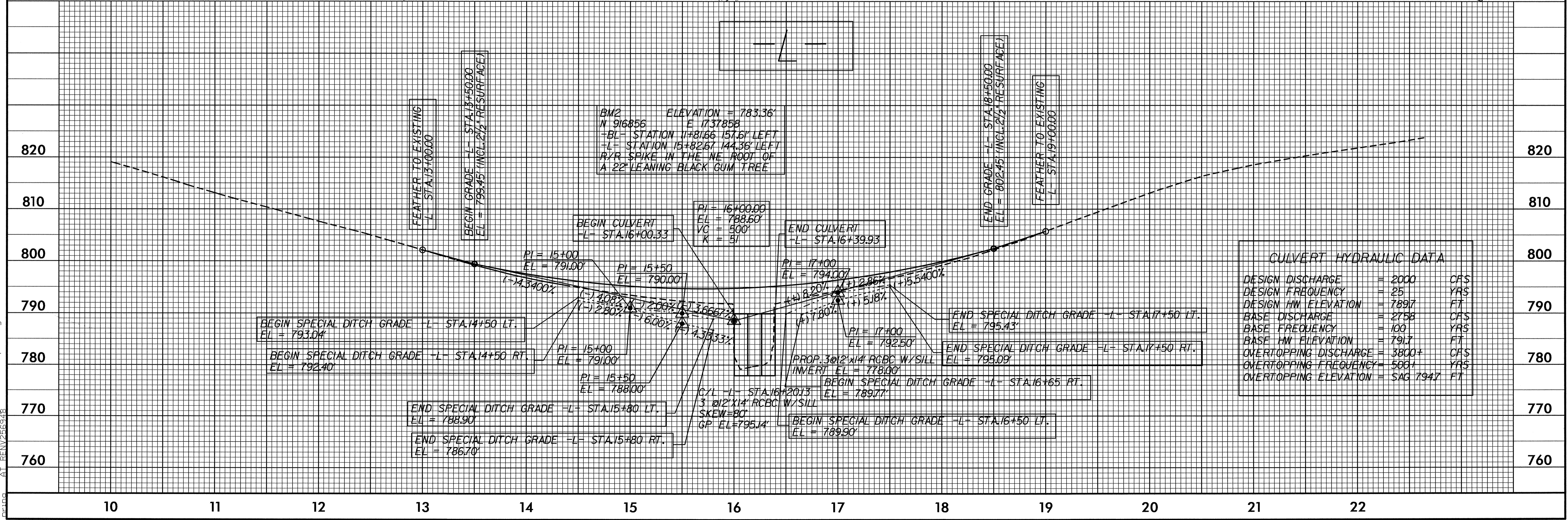

Q:\NOV-2002\1140... \Design\B4864_EC_psh4.dgn

CULVERT CONSTRUCTION SEQUENCE STA. 16+20 -L-

PROJECT REFERENCE NO. B-4864	SHEET NO. EC-5/CONST.4
RW SHEET NO.	
ROADWAY DESIGN ENGINEER	HYDRAULICS ENGINEER

PHASE I

1. UTILIZE SPECIAL STILLING BASIN(S) AS NEEDED THROUGHOUT CULVERT CONSTRUCTION.
2. REMOVE EXISTING BRIDGE.
3. CONSTRUCT IMPERVIOUS DIKE A, DIVERTING FLOW.
4. CONSTRUCT BARRELS 1 AND 2 OF PROPOSED CULVERT, AND PORTION OF INLET/OUTLET CHANNEL IMPROVEMENTS.
5. REMOVE IMPERVIOUS DIKE A.

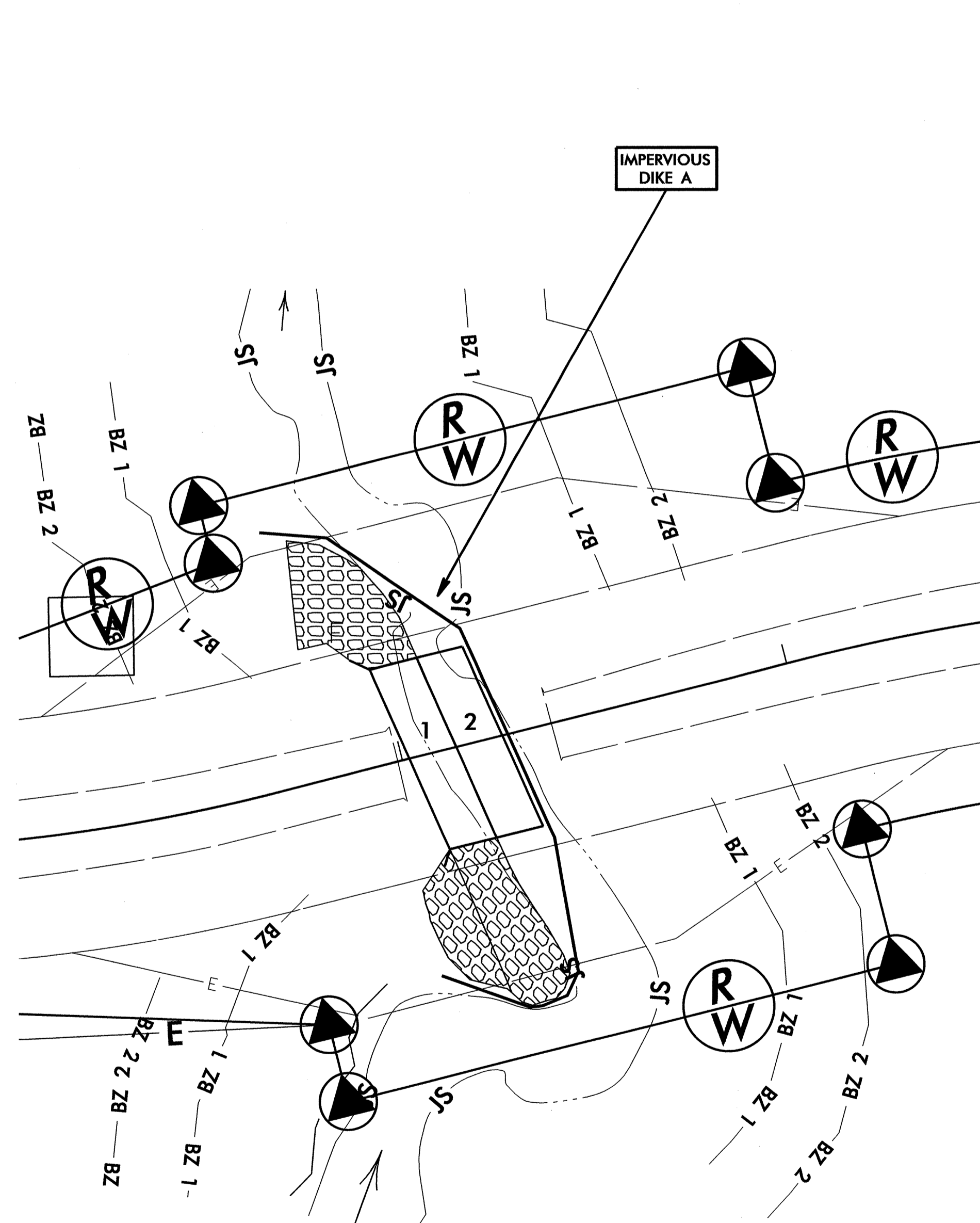

PHASE II

6. CONSTRUCT IMPERVIOUS DIKES B, DIVERTING FLOW THROUGH BARRELS 1 AND 2 OF PROPOSED CULVERT.
7. CONSTRUCT BARREL 3 OF PROPOSED CULVERT.
8. CONSTRUCT ANY REMAINING INLET/OUTLET CHANNEL IMPROVEMENTS.
9. REMOVE IMPERVIOUS DIKES B, ALLOWING NORMAL FLOW THROUGH PROPOSED CULVERT.
10. REMOVE ANY REMAINING SPECIAL STILLING BASIN(S).
11. COMPLETE ROADWAY.

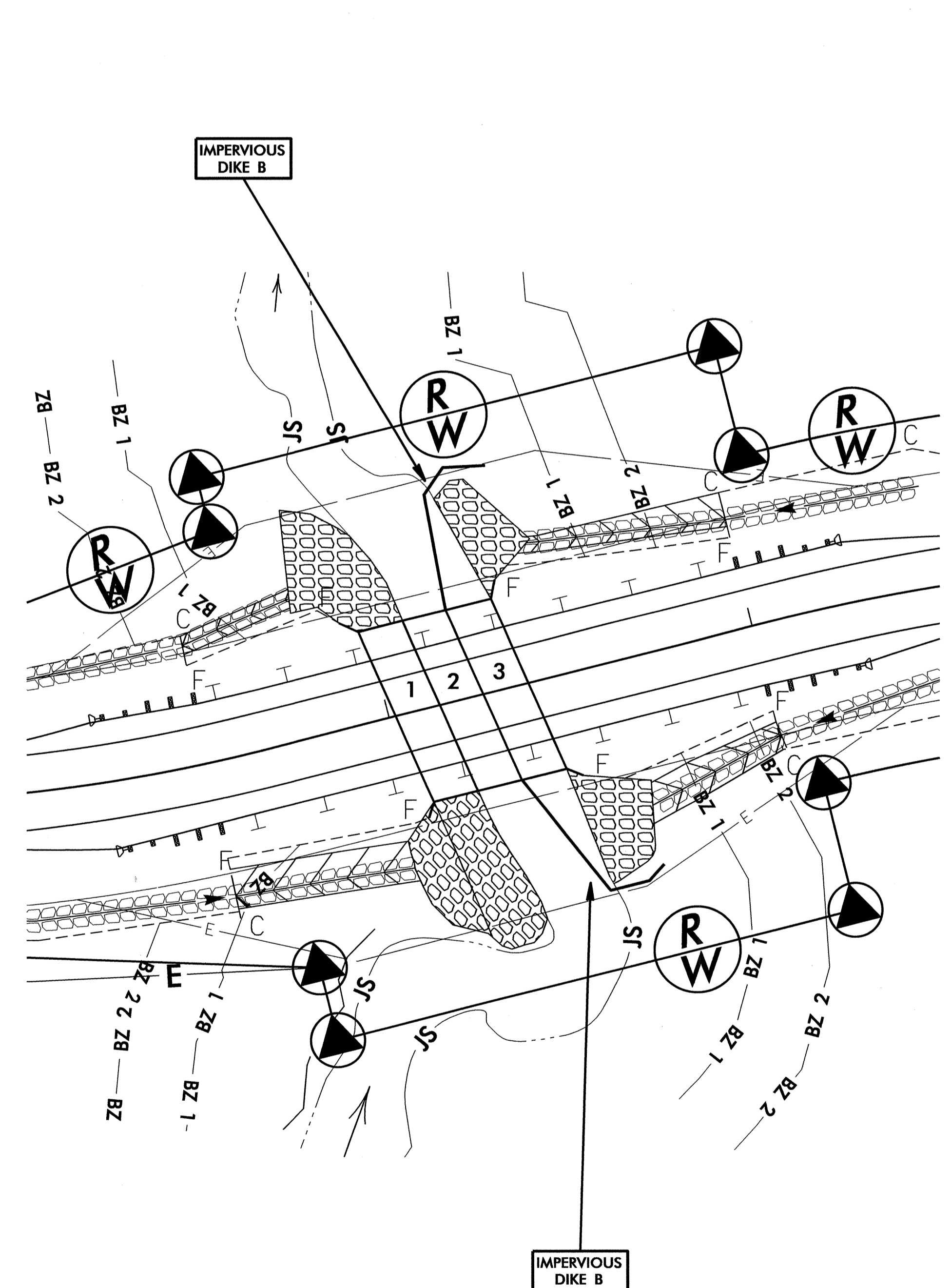

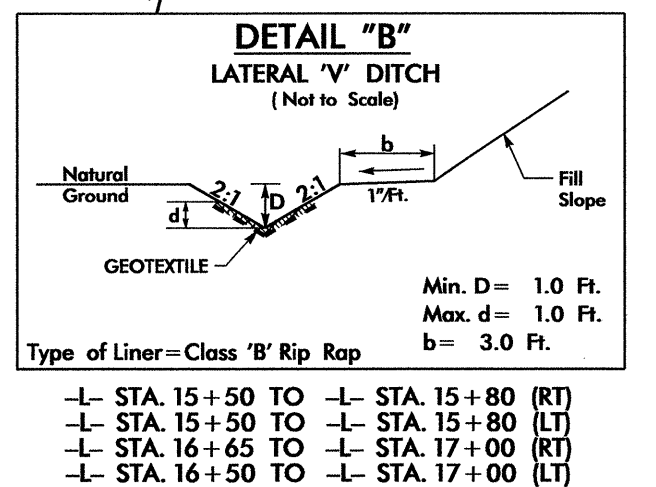
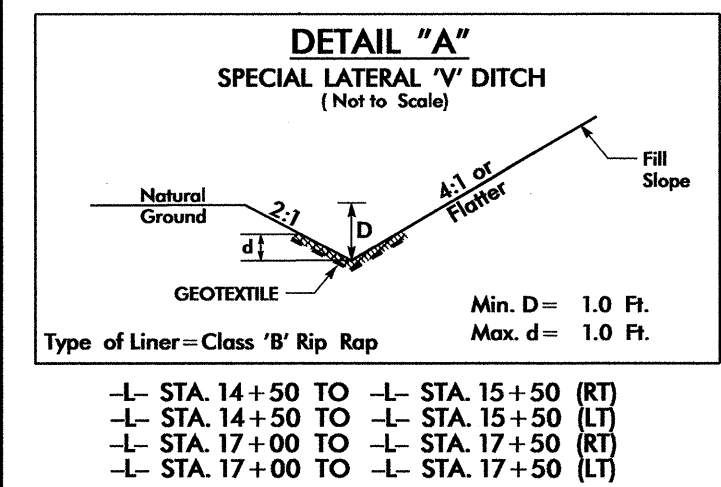
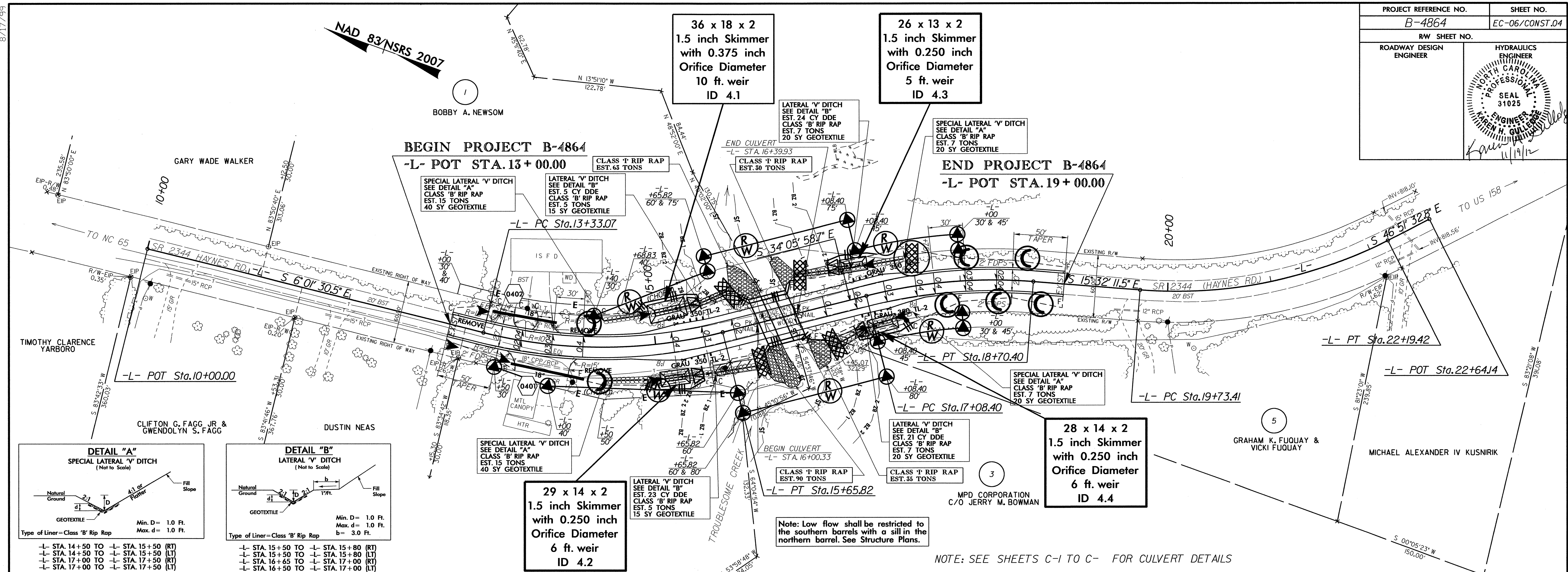

- | | |
|---------------------------------------|---------------------------------------|
| Type of Liner = Class 'B' Rip Rap | |
| -L- STA. 14+50 TO -L- STA. 15+50 (RT) | -L- STA. 15+50 TO -L- STA. 15+80 (RT) |
| -L- STA. 14+50 TO -L- STA. 15+50 (LT) | -L- STA. 15+50 TO -L- STA. 15+80 (LT) |
| -L- STA. 17+00 TO -L- STA. 17+50 (RT) | -L- STA. 16+50 TO -L- STA. 17+00 (RT) |
| -L- STA. 17+00 TO -L- STA. 17+50 (LT) | -L- STA. 16+50 TO -L- STA. 17+00 (LT) |

Note: Low flow shall be restricted to the southern barrels with a sill in the northern barrel. See Structure Plans.

NOTE: SEE SHEETS C-1 TO C- FOR CULVERT DETAILS

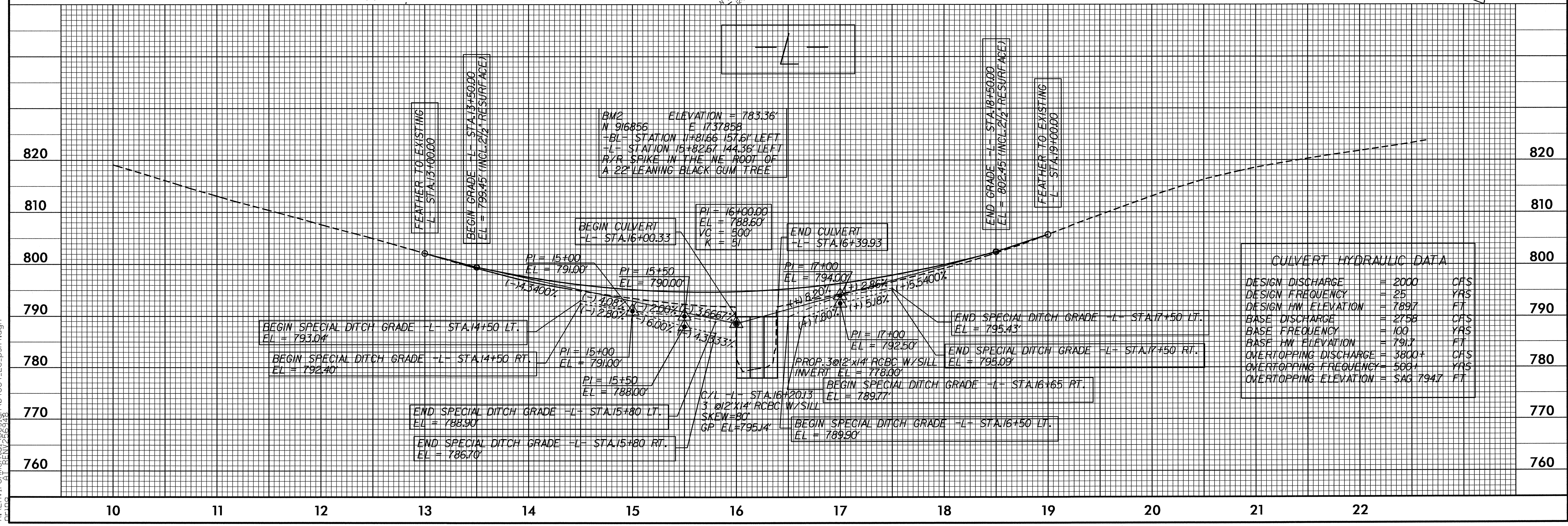

8/17/99
9/1/NOV-2012 11:40
R:\Environment\Projects\B-4864-EC-psd4.dgn